

AXEL ROOST
INTERNATIONAL EDITION

BYTE

NOVEMBER 1988

A MCGRAW-HILL PUBLICATION

REVIEWS

Compaq 386s
FlexCache 25386
Mac and PC Transputers
SpinRite
FullWrite
Zortech C++
PC Lint

PRODUCT FOCUS



Steve Jobs' new "machine for the '90s"

The NeXT Computer

- 25-MHz 68030 • Optical Drive
- Math and Digital Signal Processors
- 8 Megabytes of RAM
- Windowing Unix



IN DEPTH Parallel Processing

PLUS

Dick Pountain on:
Linn's Innovative Rekursiv Chip
Parallelizing Prolog
PC Backup Power Supplies
5 Short Takes

Debugger, Turbo Pascal 5.0

New! Turbo C® 2.0 with integrated source-level debugger

New Turbo C 2.0 is the *one* C compiler that does it all; nothing is half done or not done at all—instead, your every programming need is met. We wrote our best-selling word processor Sprint® with Turbo C; now you can write your own best seller with Turbo C 2.0.

At better than 16,000 lines a minute,* Turbo C 2.0 compiles your code 20-30% faster than its predecessor Turbo C 1.5 which was already faster than any other C compiler.

Make bugs bug off

Nice bugs are dead bugs, and Turbo C 2.0's integrated source-level debugger lets you find them and flatten them in a flash. You can set multiple breakpoints, watch variables and evaluate expressions—all from inside your integrated C environment.

Minimum system requirements: For the IBM PS/2™ and the IBM® family of personal computers and all 100% compatibles. PC-DOS (MS-DOS) 2.0 or later. Turbo Debugger minimum 384K. Turbo Assembler minimum 256K. Turbo C and Turbo Pascal minimum 448K (256K comment line version).

*Customer satisfaction is our main concern; if within 60 days of purchase this product does not perform in accordance with our claims, call our customer service department, and we will arrange a refund.

Prices and specifications subject to change without notice.

All Borland products are trademarks or registered trademarks of Borland International, Inc. Other brand and product names are trademarks or registered trademarks of their respective holders. Copyright © 1988 Borland International, Inc. B1 1290

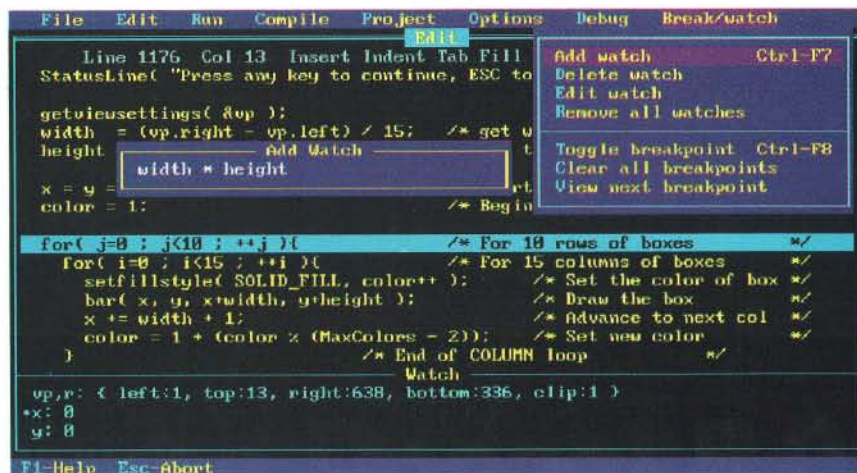

Debugging in the Turbo environment: shown here an expression is being added to the Watch window in Turbo C. The Execution Bar highlights the next line the debugger will execute.

TURBO C 2.0

HEAPSORT BENCHMARK	TURBO C 2.0	Microsoft® C 5.1
.OBJ size (bytes)	843	945
.EXE size (bytes)	6896	7731
Execution time (seconds)	8.1	12.2

FEATURE COMPARISON

Integrated debugger	Yes	No*
Inline assembly	Yes	No
Auto dependency checking	Yes	No
EMS support for edit buffer	Yes	No
Device-independent graphics	Yes	No
Number of memory models	6	5
Price	\$149.95	\$450.00

Heapsort compiled with full optimization. Benchmark run on an IBM PS/2 Model 60.

*Integrated debugger included with Quick C.

Turbo C and Turbo Pascal owners, upgrade now! CALL (800) 543-7543

If you're a registered Turbo C and/or Turbo Pascal owner, you can upgrade and get the latest version of your favorite language, plus both Turbo Assembler and Turbo Debugger, all at special upgrade prices. Whether you order by phone or mail, be sure to include your old Turbo Pascal and/or Turbo C serial numbers and the code PL02.

Mail coupon to: Borland, Attn: Dept. PL02, 1800 Green Hills Road, P.O. Box 660005, Scotts Valley, CA 95066-0005.

UPGRADE OFFERS For registered Turbo Pascal® and Turbo C® owners! (Unregistered owners, see below*)

Name _____

Shipping address _____

City () _____ State _____ Zip _____

Telephone _____

To qualify for the upgrade price you must give the serial number of the equivalent product you are upgrading.

Turbo Pascal Serial Number _____

Turbo C Serial Number _____

Upgrades for registered Turbo C and Turbo Pascal owners	Suggested Retail	Upgrade Price
Please check box(es)		
1 <input type="checkbox"/> Turbo C 2.0 Professional (Includes both Turbo Assembler and Turbo Debugger)	250.00	99.95
2 <input type="checkbox"/> Turbo Pascal 5.0 Professional (Includes both Turbo Assembler and Turbo Debugger)	250.00	99.95
3 <input type="checkbox"/> Turbo Pascal with 5.0 upgrade manual and disks	N/A	49.95
4 <input type="checkbox"/> Turbo C with 2.0 upgrade manual and disks	N/A	49.95

Please specify diskette size: Either 5¼" OR 3½"

Total product amount \$ _____

CA and MA residents add sales tax \$ _____

In US please add \$5 shipping/handling for each product \$ _____

In Canada please add \$10 shipping/handling for each product \$ _____

Total amount enclosed \$ _____

Payment: VISA MC Check Bank Draft Credit card expiration date: ____/____/____

Card # _____

Name as it appears on card _____

Turbo Assembler, Turbo C

What started modestly enough in November of 1983 with the launch of Borland's first program, Turbo Pascal® 1.0, became a revolution and it's been going like a rocket ever since.

We've changed the way you program.

We invented integrated environments with Turbo Pascal and we brought them to all our languages. Borland continues to bring you the best programming tools in the world.

New! Turbo Assembler & Turbo Debugger

Two state-of-the-art development tools in one package for only \$149.95.

New Turbo Debugger® debugs all sizes

With EMS support, remote debugging, and 386 virtual machine debugging, there's no limit to the size of program you can debug. In fact with 386 virtual machine mode, debugging takes *zero*, bytes of conventional memory!

See what's happening

Overlapping windows give you multiple views of the program you're debugging: source code, variables, CPU registers, call stack, watches, breakpoints, memory dump, and more. And a new "session-logging" feature tracks and records your every move.

You're in control

Our breakpoints give you more control than anyone else's. Ordinary debuggers only get you to a stop, then they stop. When our breakpoints are triggered you can simply stop, or you can print expressions, run code, send messages to the session log, or even evaluate an expression with user-defined function calls. And *all* our breakpoints are conditional.

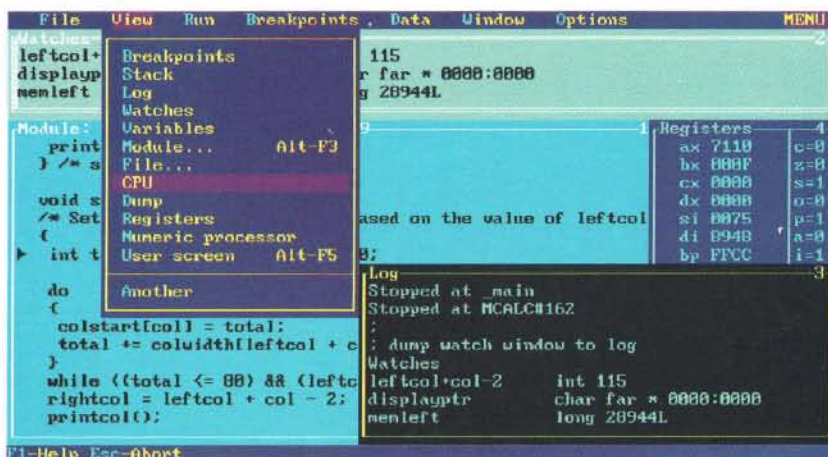

Shown here are views of source code, CPU registers, watch expressions, and a session log.

Unique Data Debugging

Plain Vanilla debuggers can only give you *code* debugging. Our new Turbo Debugger give you *data* debugging too. You can browse through your data from the simplest byte to the hairiest data structure, inspect arrays, and walk through linked lists. All by point and shoot.

Feature highlights

Breakpoints

- Actions: stop, run code, log expression
- Break on condition, memory changed
- Software ICE capabilities
- 386 debug register support
- Support for hardware debuggers

Debug any program

- Turbo Pascal, Turbo C, Turbo Assembler
- EMS support
- 386 virtual machine and remote machine debugging
- Supports CodeView® and .MAP-compatible programs

Data Debugger

- Follow pointers through linked lists
- Browse through arrays and data structures
- Change data values

New Turbo Assembler® lets you write the tightest, fastest code

Turbo Assembler is faster than other assemblers, and you can use it on your existing code. It's fully MASM compatible, 4.0, 5.0, and 5.1; even MASM can't say that. Turbo Assembler takes you beyond MASM, with significant new Assembly language extensions, more complete error checking, and full 386 support.

Turbo Assembler is designed for easy interfacing with high-level languages like Turbo Pascal and Turbo C. We use Turbo Assembler on Quattro®, our best-selling spreadsheet program; now you can write your own best-seller with Turbo Assembler!

Feature highlights

- Faster than other assemblers
- MASM compatible (4.0, 5.0, and 5.1)
- Significant new assembly language extensions
- Easy interfacing with high-level languages including Turbo C and Turbo Pascal
- Full 386 support

TURBO DEBUGGER

FEATURE COMPARISON

	TURBO DEBUGGER	CodeView®
Multiple overlapping views	Yes	No
386 virtual-86 mode debugging	Yes	No
Remote debugging	Yes	No
Data debugging	Yes	Partial
Generalized breakpoints	Yes	No
Session logging	Yes	No
Conventional memory used—80386	Zero K	230K
Conventional memory used—remote	15K	N/A

Turbo Debugger version 1.0, Microsoft CodeView version 2.2.

TURBO ASSEMBLER

BGIDEMO BENCHMARK

	TURBO ASSEMBLER	Microsoft® Assembler
Assembly time (seconds)	9.34	27.46
Link time (seconds)	4.15	10.51

FEATURE COMPARISON

	TURBO ASSEMBLER	Microsoft® Assembler
MASM compatible (4.0, 5.0, 5.1)	Yes	No
Thorough type checking	Yes	No
Nested structures and unions	Yes	No
Multimodule cross reference	Yes	No
Assemble multiple files	Yes	No

Run on IBM PS/2 model 60 using Turbo Assembler version 1.0, Turbo Linker version 2.0, Microsoft Macro Assembler version 5.10, Microsoft Overlay Linker version 3.64.

The Revolution continues with our new . . .



and Turbo C 2.0!

Turbo C 2.0 has the best of everything

- Includes the compiler, editor, and debugger, all rolled into one
- Integrated source-level debugger lets you step code, watch variables, and set breakpoints
- Develop and debug production-quality code in all six memory models
- Inline assembler support
- Support for Turbo Assembler and Turbo Debugger
- Make facility with automatic dependency checking
- Over 430 library functions, including a complete graphics library
- Only \$149.95

New Turbo C Professional

Turbo C 2.0 plus *both* Turbo Assembler & Turbo Debugger: all three programs rolled into one—the *one* C package that has everything. A complete set of tools that caters to every level of programming expertise. Turbo C Professional: \$250. Includes coupon for free T-shirt (while supplies last).

New! Turbo Pascal® 5.0 with integrated source-level debugger

Turbo Pascal, the worldwide favorite with over a million copies in use, just got even smarter. The best got better. Meet Version 5.0. In a word, it's revolutionary.

Not only do you go code-racing at more than 34,000 lines a minute,* you also now go into a sophisticated debugging environment—right at source level.

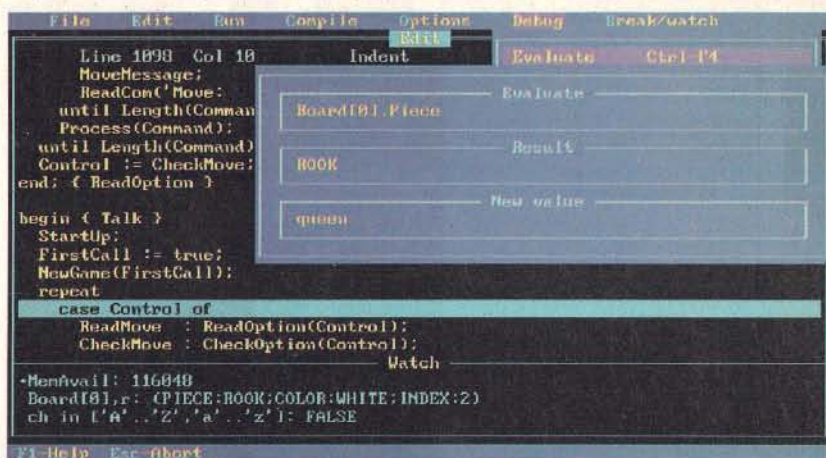

Shown here is the Evaluate/Modify window of Turbo Pascal: look at expressions, examine structured data types, change variables on the fly.

It's completely integrated and bullet-fast.

Turbo Pascal's new integrated debugger takes you inside your code for fast fixes. You step, trace, set multiple breakpoints. You modify variables as you debug and watch full expressions at runtime.

Separate Compilation

Break your code into units. Your separately compiled units can be shared by multiple programs and linked in a flash with Turbo Pascal's built-in Make utility and smart linker. We give you a powerful library of standard units including the spectacular Borland Graphic Interface and our state-of-the-art overlay manager.

Feature highlights

- Includes the compiler, editor, and debugger, all rolled into one
- Integrated source-level debugger lets you step code, watch variables, and set breakpoints
- Overlays, including EMS support
- 8087 floating-point emulation
- Support for Turbo Assembler and Turbo Debugger
- Procedural types, variables, and parameters
- Smaller, tighter programs: Smart Linker strips both unused code and data
- Constant expressions
- EMS support for editor
- Only \$149.95

Debugging: The inside story

Turbo Pascal's new integrated source-level debugger takes you inside your code to fix errors fast. Don't worry about errors, everyone makes them; but with the right debugger, this one, it's a fast fix.

Turbo Pascal Professional®

Turbo Pascal 5.0 plus *both* Turbo Assembler & Turbo Debugger: all three programs rolled into one—the *one* Pascal package that has everything. A complete set of tools that caters to every level of programming expertise. Turbo Pascal Professional: \$250. Includes coupon for free T-shirt (while supplies last).

TURBO PASCAL 5.0	TURBO PASCAL 5.0	Turbo Pascal 4.0
SIEVE BENCHMARK		
.EXE size (bytes)	1440	1504
Execution time (seconds)	6.15	7.25
FEATURE COMPARISON		
Integrated debugger	Yes	No
Overlays, including EMS support	Yes	No
8087 floating-point emulation	Yes	No
Turbo Debugger support	Yes	No
Procedural types, variables, parameters	Yes	No
Smart linking of code and data	Yes	No
Constant expressions	Yes	No
EMS support for editor	Yes	No

Benchmark (25 iterations) run on an IBM PS/2 Model 60.

60-day money-back guarantee†

BORLAND
Circle 50 on Reader Service Card (DEALERS: 51)

For the dealer nearest you
Call (800) 543-7543

BYTE

NOVEMBER 1988

VOL. 13/NO. 12

PRODUCTS IN PERSPECTIVE

67 What's New

89 Short Takes

NEC Ultralite, *an incredible shrinking machine*

NEC ProSpeed 386,
a 386 portable

The Norton Commander,
a useful product is now nearly indispensable

Compaq Deskpro 386/20E,
going head-to-head with the PS/2
Personal Measure,
performance analysis from a real-world perspective

FIRST IMPRESSIONS

158 The NeXT Computer

by Tom Thompson and Nick Baran

This power user's dream includes a 25-MHz 68030, 8 megabytes of RAM, Unix, and more.

REVIEWS

180 Product Focus: The Promise of Project Management

by Lamont Wood

Project management software has both potential and pitfalls.

197 SX Appeal

by Jeff Holtzman

The Compaq 386s—the first system based on Intel's new 80386SX microprocessor.

205 ALR Improves on a Winner

by Mark L. Van Name

ALR's FlexCache 25386 sets a new speed record for 80386 systems.

213 Parallel Processing Comes to PCs

by Pete Wilson

The Levco TransLink and CSA PART boards can provide parallel processing and boost the power of your system.



The NeXT Computer/158

EXPERT ADVICE

105 Computing at Chaos Manor: The Revenge of the File Formats

by Jerry Pournelle

It was a frantic month of unfinished business at Chaos Manor.

127 Applications Plus: Portable Software

by Ezra Shapiro

Ezra looks at programs packed in ROM and compares OS/2 and Spuds MacKenzie.

135 Down to Business: Do Productivity Tools Help Productivity?

by Wayne Rash Jr.

Buying software productivity tools may be pointless if you haven't analyzed your needs.

139 Macinations: Hot Stuff

by Don Crabb

The products that outshined the rest at the recent MacWorld Expo.

147 OS/2 Notebook: OS/2's Multitasking Dashboard

by Mark Minasi

Some new tuning parameters are important in multitaskers.

153 COM1:

You Can't Get There from Here—Or Can You?

by Brock N. Meeks

Today's gateway experiments could pave the way for a nationwide network.

223 A C++ Toolkit

by Jon Udell

Zortech's C++ 1.0—everything you need to get started with C++.

229 Lint for the PC

by Alex Lane

PC-Lint 2.15 is an MS-DOS version of the Unix tool.

237 SpinRite

by Richard Grehan

Recover bad sectors and tracks of data on your hard disk drive.

241 Features vs. Speed

by Diana Gabaldon

FullWrite Professional combines word processing and desktop publishing capabilities.

249 Remote-Control Communications

by Rick Cook and Paul Schauble

Remote2's R2Call/R2Host let you control another computer via your modem.

254 Review Update

IN DEPTH

272 Introduction: Parallel Processing

275 Side by Side

by Klaus K. Obermeier

Parallel-processing capabilities for personal computers are slowly emerging.

287 T800 and Counting

by Richard M. Stein

The T800 transputer and the Occam language are a hardware/software team designed to work together.

301 Getting the Job Done

by David Gelernter

The Linda language can help parallelize existing software and develop new program structures.

311 The Third Dimension

by Michael J. Little
and Jan Grinberg

The massively parallel architecture of the 3-D Computer ensures high throughput.

320 Boards and Boxes

Currently available transputer boards and parallel-processing desktops.



Parallel Processing/272

**409 Some Assembly Required:
Embedded Languages**

by David Betz

ExTalk extends the capabilities of your application.

**419 Programming Insight:
Adding Dimension**

by Christopher J. Batory

A technique that provides the fastest possible access to an array element in C.

FEATURES

340 Recursiv:

An Object-Oriented CPU

by Dick Pountain

The Linn Rekursiv CPU is designed to run object-oriented languages faster than conventional machines.

353 PC Power, Part 2:

Backup Power

by Mark Waller

How to provide reliable backup power for your computer without creating new electrical problems.

363 Multiple Regression with Excel

by Charles W. Kyd

Microsoft Excel lets you do powerful regression analysis.

375 It's APT to Write

by Peter Wayner

The Abstract Planning Tool makes logical connections from your thoughts and ideas.

387 Parallelizing Prolog

by Dick Pountain

Three approaches to running Prolog programs on multiprocessor machines.



Rekursiv/340

DEPARTMENTS

6 Editorial: BYTEweek, BYTE on Disk, and Best of BIX

11 Microbytes

24 Letters

33 Chaos Manor Mail

38 Ask BYTE

51 Book Reviews

467 Coming Up in BYTE

READER SERVICE

466 Editorial Index by Company

468 Alphabetical Index to Advertisers

470 Index to Advertisers by Product Category

Inquiry Reply Cards: after 472

PROGRAM LISTINGS

From BIX: see 396

From BYTEnet:
call (617) 861-9764

On disk or in print:
see card after 288

HANDS ON

**399 Ciarcia's Circuit Cellar:
A Supercomputer, Part 2**

by Steve Ciarcia

In this installment, Steve examines the Mandelbrot set.

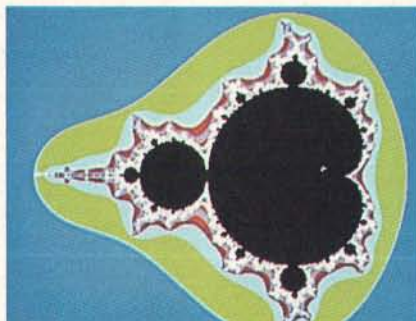

Circuit Cellar/399

BYTE (ISSN 0360-5280) is published monthly with an additional issue in October by McGraw-Hill, Inc. Postmaster: Send address changes, USPS Form 3579, undeliverable copies, and fulfillment questions to BYTE Subscriptions, P.O. Box 553, Hightstown, NJ 08520. Second-class postage paid at Peterborough, NH 03458 and additional mailing offices. Postage paid at Winnipeg, Manitoba. Registration number 9321. Printed in the United States of America.

Not responsible for lost manuscripts or photos. Opinions expressed by the authors are not necessarily those of BYTE.

Copyright © 1988 by McGraw-Hill, Inc. All rights reserved. Trademark registered in the United States Patent and Trademark Office.



Subscription questions or problems should be addressed to: BYTE Subscriber Service, P.O. Box 553, Hightstown, NJ 08520.

BYTE

EDITOR IN CHIEF
Frederic S. Langa

OPERATIONS
Glenn Hartwig *Associate Managing Editor*

REVIEWS (Hardware, Software, Product Focus)
Cathryn Baskin *Associate Managing Editor*, Dennis Allen *Senior Technical Editor, Software*, Stephen Apiki *Testing Editor, BYTE Lab*, Stanford Diehl *Testing Editor, BYTE Lab*

NEWS AND TECHNOLOGY (Microbytes, What's New, Short Takes)
Rich Malloy *Associate Managing Editor*, D. Barker *Senior Editor, News and Technology*, Anne Fischer *Leit Senior Editor, New Products*
Peterborough: Roger Adams *Associate News Editor*, David Andrews *Associate News Editor*, Martha Hicks *Associate News Editor*
West Coast: Gene Smarte *Bureau Chief*, Costa Mesa, Nicholas Baran *Technical Editor*, San Francisco, Frank Hayes *Associate News Editor*, Marlene Nesary *Associate News Editor*, Jeffrey Bertolucci *Editorial Assistant*, San Francisco

SENIOR TECHNICAL EDITORS
Ken Sheldon *Features*, Jane Morrill *Tazelaar In Depth*, Richard Grehan *At Large*, Tom Thompson *At Large*

TECHNICAL EDITORS
Janet J. Barron, Janet Fiderio, Jon Udell, Stanley Wszola

ASSOCIATE TECHNICAL EDITOR
Robert Mitchell

CONSULTING EDITORS
Steve Ciarcia, Jerry Pournelle, Ezra Shapiro, Don Crabb, Brock N. Meeks, Mark Minasi, Wayne Rash Jr.

CONTRIBUTING EDITORS
Jonathan Amsterdam *Programming Projects*, Mark Dahmke *Video, Operating Systems*, Mark Haas *At Large*, Rik Jadrnicek *CAD, Graphics, Spreadsheets*, Robert T. Kurosaka *Mathematical Recreations*, Alastair J. W. Mayer *Software*, Stan Mlastkowski *New Technology*, Alan R. Miller *Languages and Engineering*, Dick Pountain *Algorithms*, Roger Powell *Computers and Music*, Phillip Robinson *Semiconductors*, Jon Shiell *High-Performance Systems*, Ernest Tello *Artificial Intelligence*

COPY EDITORS
Lauren Stickler *Chief*, Susan Colwell, Judy Connors-Tenney, Jeff Edmonds, Nancy Hayes, Cathy Kingery, Margaret A. Richard, Warren Williamson

EDITORIAL ASSISTANTS
Peggy Dunham *Office Manager*, Linda C. Ryan, June N. Sheldon, Lynn Susan Valley

ART
Nancy Rice *Director*, Joseph A. Gallagher *Assistant Director*, Jan Muller *Assistant*, Alan Easton *Technical Artist*

PRODUCTION
David R. Anderson *Director*, Virginia Reardon *Senior Editorial Production Coordinator*, Denise Chartrand *Editorial Production Coordinator*, Michael J. Lonsky *Editorial Production Coordinator*

TYPOGRAPHY
Sherry Fiske *Systems Manager*, Donna Sweeney *Applications Manager*, Christa Patterson

ADVERTISING/PRODUCTION (603) 924-6448
Lisa Wozmak *Director*, Lyda Clark *Senior Account Coordinator*, Karen Cillay, Linda Fluhr, Jeanne Gatcombe, Brian Higgins, Rod Holden, Wai Chiu Li *Quality Control Manager*, Julie Murphree *Advertising/Production Coordinator*

EDITORIAL AND BUSINESS OFFICE:
One Phoenix Mill Lane, Peterborough, NH 03458, (603) 924-9281.
West Coast Branch Offices: 425 Battery St., San Francisco, CA 94111, (415) 954-9718; 3001 Red Hill Ave., Building #1, Suite 222, Costa Mesa, CA 92626, (714) 557-8292.
New York Branch Editorial Office: 1221 Avenue of the Americas, New York, NY 10020, (212) 512-3175.
BYTEnet: (617) 861-9764 (set modem at 8-1-N or 7-1-E; 300 or 1200 baud).
Fax: (603) 924-7507. **Telex:** (603) 924-7861.
SUBSCRIPTION CUSTOMER SERVICE: Outside U.S. (201) 837-1315; Inside U.S. (800) 423-8272.

Officers of McGraw-Hill Information Services Company: President: Welter D. Serwatka. Executive Vice Presidents: Kenneth E. Gazzola, Aerospace and Defense; Ira Herenstein, Computers and Communications; Russell C. White, Construction; Robert P. McGraw, Healthcare; Brian H. Hall, Legal. Senior Vice Presidents-Publishers: Laurence Altman, Data Communications; David J. McGrath, Engineering News-Record. Senior Vice Presidents: Robert D. Daleo, Finance; Michael J. Koeller, Human Resources. Group Vice Presidents: J. Burt Totaro, BYTE; Norbert Schumacher, Energy/Process Industries. Vice Presidents: George Elsingher, Circulation; Julia Lenard, Systems Planning and Technology.
Officers of McGraw-Hill, Inc.: Joseph L. Dionne, Chairman, President, and Chief Executive Officer; Robert N. Landes, Executive Vice President, General Counsel, and Secretary; Robert J. Bahash, Executive Vice President and Chief Financial Officer; Frank D. Penglass, Senior Vice President, Treasury Operations.

PUBLISHER/GROUP VICE PRESIDENT
J. Burt Totaro

ADVERTISING SALES
Dennis J. Riley *Director*, (603) 924-8281
Sandra Foster *Administrative Assistant*

Jennifer L. Bartel *West Coast Sales Manager*, (214) 644-1111

NEW ENGLAND
ME, NH, VT, MA, RI, ONTARIO, CANADA & EASTERN CANADA
John C. Moon (617) 262-1180

ATLANTIC
NY, NYC, CT, NJ (NORTH)
Leah G. Rabinowitz (212) 512-2096
(203) 968-7111

EAST
PA, KY, NJ (SOUTH), MD, W. VA, DE, DC
(215) 496-3833

SOUTHEAST
NC, SC, GA, FL, AL, TN, VA
Thomas H. Tolbert (404) 252-0626

MIDWEST
IL, MO, KS, IA, ND, SD, MN, WI, NE, IN, MI, MS, OH
Bob Denmead (312) 751-3740

SOUTHWEST, ROCKY MOUNTAIN
CO, WY, OK, TX, AR, LA
Karl Heinrich (713) 462-0757

SOUTH PACIFIC
SOUTHERN CA, AZ, NM, LAS VEGAS
Jack Anderson (714) 557-8292
Tom Harvey (213) 480-5243

NORTH PACIFIC
HI, WA, OR, ID, MT, NORTHERN CA, NV (except LAS VEGAS), UT, WESTERN CANADA
Mike Kisseberth (415) 362-4600
Bill McAfee (415) 349-4100

TELEMARKETING
L. Bradley Browne *Director*
Susan Boyd *Administrative Assistant*

BYTE BITS (2x3)
Dan Harper (603) 924-6830

THE BUYER'S MART (1x2)
Mark Stone (603) 924-3754

REGIONAL ADVERTISING SECTIONS
MID-ATLANTIC, METRO NY & NEW ENGLAND, SOUTHERN CALIFORNIA
Elisa Lister (603) 924-6830

MIDWEST, PACIFIC NORTHWEST, METRO NY & NEW ENGLAND
Scott Gagnon (603) 924-6830

SOUTHEAST, SOUTHWEST
Liz Coyman (603) 924-9281

BYTE DECK MAILINGS
National
Ed Ware (603) 924-6166

A/E/C COMPUTING DECK
COMPUTING FOR ENGINEERS DECK
Mary Ann Goulding (603) 924-9281

INTERNATIONAL ADVERTISING SALES STAFF
See listing on page 469.

Founder: James H. McGraw (1860-1948). Executive, editorial, circulation, and advertising offices: One Phoenix Mill Lane, Peterborough, NH 03458, phone (603) 924-9281. Office hours: Monday through Thursday 8:30 AM-4:30 PM, Friday 8:30 AM-1:00 PM, Eastern Time. Address subscriptions to BYTE Subscriptions, P.O. Box 7843, Teaneck, NJ 07666-9866. Subscriptions are \$22.95 for one year, \$39.95 for two years, and \$55.95 for three years in the U.S. and its possessions. In Canada and Mexico, \$25.95 for one year, \$45.95 for two years, \$64.95 for three years. \$75 for one-year air delivery to Europe. Y28,800 for one-year air delivery to Japan. Y14,400 for one-year surface delivery to Japan. \$40 surface delivery elsewhere. Air delivery to selected areas at additional rates upon request. Single copy price is \$3.50 in the U.S. and its possessions, \$3.95 in Canada, \$4.50 in Europe, and \$5 elsewhere. Foreign subscriptions and sales should be remitted in U.S. funds drawn on a U.S. bank. Please allow six to eight weeks for delivery of first issue. Address editorial correspondence to: Editor, BYTE, One Phoenix Mill Lane, Peterborough, NH 03458. Unacceptable manuscripts will be returned if accompanied by sufficient postage. Where necessary, permission is granted by the copyright owner for libraries and others registered with the Copyright Clearance Center (CCC) to photocopy any article herein for the flat fee of \$1.50 per copy of the article or any part thereof. Correspondence and payment should be sent directly to the CCC, 29 Congress St., Salem, MA 01970. Specify ISSN 0360-5280/83, \$1.50. Copying done for other than personal or internal reference use without the permission of McGraw-Hill, Inc. is prohibited. Requests for special permission or bulk orders should be addressed to the publisher. BYTE is available in microform from University Microfilms International, 300 North Zeeb Rd., Dept. PR, Ann Arbor, MI 48106 or 18 Bedford Row, Dept. PR, London WC1R 4EJ, England. BYTE and **BYTE** are registered trademarks of McGraw-Hill, Inc.

Integrated Software for Schematics & PCB Artwork



Introducing HiWIRE®-Plus

Wintek's smARTWORK® pioneered low-cost printed-circuit-board CAD. Then HiWIRE set the standard for productivity and ease-of-use in schematic capture. Now Wintek introduces HiWIRE-Plus, integrating HiWIRE's schematic features with a powerful printed-circuit-design facility.

Creating Schematics

With HiWIRE-Plus, simply connect library symbols with wires and buses. Creating and changing symbols is fast and painless. Produce your drawing using a dot-matrix printer, laser printer, or pen plotter.

Circuit-Board Design

HiWIRE-Plus gives you all the design freedom you want: you choose the grid size, trace widths, and pad shapes. The board size and number of layers are virtually unlimited. HiWIRE-Plus is perfect for surface-mount, micro-strip, and ECL applications.

CURRENT VERSIONS
HiWIRE, V1.1r4; smARTWORK, V1.4r1

HiWIRE-Plus Advantages

- One tool for schematics and printed-circuit artwork
- Easy-to-learn menu-driven operation; complete documentation and tutorial
- Schematic libraries with TTL, CMOS, ECL, ladder, micro-processor, and discrete components
- Netlist and bill-of-materials utilities included
- Circuit boards up to 60x60 inches and 256 layers
- Variable grid size, trace width, and pad size (.001" resolution)
- PCB library with DIPs, SIPs, SMDs, PGAs, TOs, and edge and D connectors
- Schematic-to-layout cross-checking
- Design-rule checker
- 800 number for free support



"HiWIRE", "smARTWORK", "Wintek", and the Wintek logo are registered trademarks of Wintek Corporation.

System Requirements

- IBM PC, XT, AT, or PS/2 with 512K RAM, printer port, color monitor, and CGA, EGA, or VGA graphics card
- Microsoft Mouse
- IBM ProPrinter or Epson dot-matrix printer, and/or
- Houston Instrument or Hewlett-Packard pen plotter

Higher Performance Better Value

Still only \$895, HiWIRE-Plus delivers quality schematics and PCB artwork. You don't need to guess if HiWIRE-Plus is right for you — *we guarantee it!* Try it for 30 days at absolutely no risk. Call toll free today and put HiWIRE-Plus to work for you.

Wintek Corporation

1801 South Street
Lafayette, Indiana 47904-2993
(800) 742-6809 or
(317) 742-8428
FAX: (317) 448-4823
Telex: 70-9079

Europe: RIVA Ltd., England,
Phone: 0420 22666, FAX: 0420 23700
Australia: Entertainment Audio Pty, Ltd.,
Phone: (08) 363-0454

BYTEWEEK, BYTE ON DISK, AND BEST OF BIX

New tools from BYTE to help you manage information overload

Information overload is something we all struggle with—especially in the computer press, which seems to suffer from a disappointingly low signal-to-noise ratio. Not only are there more and more publications dealing with this or that niche, but the quality of reporting frequently proves to be less than stellar.

For example, several of the large weekly publications have well-deserved reputations for low accuracy.

Others (the "Reviews 'R' Us" sort of publications) take a notoriously short-sighted approach to microcomputing. Yes, "state-of-the-market" reviews are important, but the "state of the art" is equally important. Unlike BYTE, a here-and-now, mostly reviews publication can't give you the information you need to prepare for *tomorrow*. That's why we strive to give you an accurate, balanced, useful-today *and* useful-tomorrow magazine.

BYTEweek

Even so, BYTE's staff learns of far more interesting and useful information than we can fit into a magazine, even the size of the one you're now holding. Much of this "extra" information goes into our popular Microbytes Daily news service on BIX (BYTE's on-line conferencing system), where it has earned a reputation for being a fast, reliable source for reports and analysis of significant microcomputing news.

But Microbytes Daily is still a lot of reading. So, several months ago, we asked our News and Technology department to design a weekly newsletter that would, in a compact and readable form, give readers 100 percent factual, unbi-

ased, expert analysis of significant developments in the personal computer industry. It was a tall order—no other microcomputing weekly places so high a premium on accuracy, for example. But, using the resources of our award-winning Microbytes news team, the technical expertise of the BYTE staff, and the resources of the BYTE Lab, Associate Managing Editor Rich Malloy and his staff has succeeded.

The first issues of BYTEweek rolled off the press in October. Now, each week, Rich, Nick Baran, D. Barker, and the rest of the News and Technology department sort through the week's events (including information provided exclusively to BYTEweek, BYTE, and Microbytes), distill the most significant news, and add expert interpretation and evaluation to tell you not just what happened, but why, and what it means. The results are desktop-published for utmost speed and mailed to arrive at readers' desks on Monday mornings. (BYTEweek subscribers also can download each issue from BIX for even faster access.)

If you need the most accurate and timely information available—especially if you're suffering from information overload—our concise, precise BYTEweek newsletter can help. For more information, please see page 271.

BYTE on Disk

There's a shelf in my office that I worry about. It's the one with the full collection of BYTES. In part, I worry about folks borrowing some of those old, irreplaceable issues for research. Mostly, I worry about the shelf being able to support all that weight. It's a literal case of information overload.

One alternative to paper archives is to use BIX to keyword-search and download BYTE articles; another alternative is to build your own electronic archives with the BYTE on Disk service.

BYTE on Disk offers the full text of each issue of BYTE in a variety of disk

formats. The files are plain-vanilla ASCII (no graphics), so they can be searched, read, or imported into almost any word processor, database, or text-retrieval utility you might have. Because it's full text, you're not locked into anyone else's keywords or index—you can search for any occurrence of any word in any article.

It's great for research and reference—instead of manually thumbing through an issue, trying to remember where you saw that mention of the TechnoWidget 999 coprocessor, you just use something like Norton's Text Search or your word processor to search for "widget," "techno," "999," or "coprocessor," and voilà—you've found it! For more information, please see the card following page 288.

Best of BIX

We're also now producing disks with the highlights of each month's activity on BIX. Like BYTE on Disk, Best of BIX on Disk is plain ASCII, so you can read and search the text with almost any word processor, database, or text utility. Each disk contains the most interesting and informative recent discussions specific to the machine you own. For example, order the IBM disk, and you'll get highlights from IBM-specific conferences. Please see the card following page 288 for additional information.

A monthly magazine that gives you a thorough, in-depth, one-stop briefing on important developments across the entire field of personal computing; a weekly newsletter that gives you accurate, concise reporting and evaluation of microcomputing news; compact, machine-readable/searchable versions of BYTE and Best of BIX. We're proud to be the first publication to offer these tools to help you find and use the information you need, when you need it, in the format you prefer.

—Fred Langa
Editor in Chief
(BIX name "flanga")

Here's One '286 Computer That Won't Be Shocked By The Next Generation.



AST Advanced
FASTRAM

AST Premium
FASTboard 386

Two kinds of people buy the award-winning AST Premium® /286: those who live for today and those concerned about the future.

People who live for today buy the AST Premium/286 because it's the hottest 286 on

	AST Premium/286 Model 140X	IBM® PS/2™ Model 50Z 031	Compaq® DeskPro 286™ Model 40
CPU speed (MHz)	10, 8, 6	10	12, 8
Wait States	0	0	1
Max. 0 Wait-State Memory	16 MB	2 MB	0 MB
Expanded Memory	EEMS/EMS 4.0 Included	Extra Cost	Extra Cost
Hard Disk Size/Speed	40 MB/28ms	30 MB/39ms	40 MB/28ms
DOS 3.3 and GW-BASIC*	Included	Extra Cost	Extra Cost
Easy 386 CPU Upgradeability	Yes	No	No

the market. In fact, among its many distinctions is the "Best of '87" award given by PC Magazine. But for those who can't stop thinking about the demands of the next generation of application software, the AST Premium/286 represents something different. Security.

Only the AST Premium/286 offers up to 16 MB of zero wait-state RAM, using AST Advanced FASTRAM™ memory. Which is the kind of wide-

★★★
**Top Rated
'286 PC**
—PC Digest™
May 1988

open power you need to run memory-intensive Lotus® 1-2-3® and dBASE® applications today.

Plus, you're all set to take advantage of applications written for MS® OS/2™ from AST in the future. In fact, in NSTL's latest independent OS/2 system benchmarks, AST Premium/286 finished first.*

And when you're ready for 386™ CPU power, AST's proprietary FASTslot™ architecture provides easy upgradeability. Simply plug in the AST Premium FASTboard/386™ for true 32-bit, 16 MHz power with high-speed 64Kb cache memory.

To find out more, visit your nearest AST authorized system dealer today, or call **(714) 863-0181** and ask for **operator AA75**.

Please send information on the AST Premium/286.

Yes, have an AST representative call me.

Name _____

Title _____

Company _____

Address _____

City _____ State _____ Zip _____

Phone (____) _____

I am an End user Reseller.

Send to: AST Research, Inc. 2121 Alton Avenue
Irvine, California 92714-4992, Attn: M.C.

BYTE 11/88

AST
RESEARCH INC.

AST is proud to
sponsor NBC's
telecast of the 1988
Summer Olympics



Times Have Changed.

*PC Digest, May 1988. Independent Comparative Ratings Report for selecting PC Systems and Peripherals. AST markets products worldwide—in Europe and the Middle East call 44 1 568 4350; in Japan call 813 447 8303; in the Far East call 852 5 717223; in Canada call 416 826-7514. AST, AST logo and AST Premium registered and FASTslot, FASTRAM, and AST Premium FASTboard/386 trademarks AST Research, Inc. 386 trademark Intel Corp. All other product and brand names are trademarks and registered trademarks of their respective companies. Copyright © 1988 AST Research, Inc. All rights reserved.

Circle 32 on Reader Service Card (DEALERS: 33)

UserSoft/C Means Business

*** Sample INPUT & OUTPUT of Business C, S/AM, SUPERIOR and SCREEN ***

programmed by Mr. Smith's maiden name is Anderson

Who are you ? Well.... I am Peter

Please enter the filename for Sales History : c:SALES

enter range of names (FROM ... TO ...) : let's start FROM Gibbens TO Maple

>> password for file[c:SALES] is *****

REPORT

Novem/15 1988 - TUE

575-83-4990 Gibbens	- sport	\$44,637.00DR
486-00-1533 Hagen	- cosme	\$23.20CR
692-54-7311 Hamilton	- retai	\$191.95CR
575-72-1638 Jackson	- retai	\$3,144.06DR
394-50-1123 Lampman	- sport	\$98.63DR
105-33-6296 MacDonald	- cosme	\$2.45CR

*** END ***

```
#include "usersoft.h"
#include "business.h"
main()
{
  char * name, * username, * lastname,
        * from_name, * to_name,
        * createfilespec, * salesfile;
  SAMPLE * infile;
  char * ssn, * salesman, division[10];
  VALUE amount;
  /*----- Prompt User for filename and -----*/
  initscr(); _clear(); /* SCREEN */
  Print();
  /*----- Sample INPUT & OUTPUT of Business C, S/AM, SUPERIOR and SCREEN -----*/
  at(2,0)
  name IS("Thomas M. Anderson Smith") /* Business C */
  PRINTF("programmed by %s(%4) %s(%-1); his maiden name is %s(%10,-2); \n",
        "Mr.", name, name) /* SUPERIOR */
  PRINTF("Who are you ?") /* SUPERIOR */
  READF ("?"-1 an", "M", username) /* SUPERIOR */
  PRINTF("Please enter the filename for Sales History ?") /* SUPERIOR */
  SCANF ("AW", salesfile) /* SUPERIOR */
  PRINTF("Enter range of names (FROM ... TO ...) ?") /* SUPERIOR */
  SCANF ("%d"-"FROM" %s %d"-"TO" %s",
        from_name, to_name) /* SUPERIOR */
  /*----- open primary and all secondary(alternative) files -----*/
  /* Note: #1 are to be replaced by actual filenames */
  if (OPEN(infile,
          REPLACE("FILENAME=#1;UPDATE;PW=PRODT", "#1", salesfile)))
  {
    PRINTF("\n%s(%5) %d/%d-%d yyyy - DATE'\n\n", /* SUPERIOR */
          "REPORT -----", date(1988,11,15));
    LOCATE(infile, "NAME"=from_name, #KORSE) /* S/AM */
    READNEXT(infile, ssn, salesman, division, PTR amount) /* S/AM */
    /* read the next record in table(may be alternate) set by LOCATE() */
    while (! EOR(infile)
          AND (strcmp(salesman, from_name) >= 0)
          AND (strcmp(salesman, to_name) <= 0))
    {
      lastname = TRIM(STRIP("LW(1,1)", salesman)) /* SUPERIOR */
      FWRITE(stdout, /* SUPERIOR */
            " Q'888-88-8888' (20) - A(5) P'555,555V.9NC'\n\n",
            ssn, lastname, division, amount);
      READNEXT(infile, ssn, salesman, division, PTR amount) /* S/AM */
    }
    CLOSE(infile) /* S/AM */
    PRINTF("**** End ****") /* SUPERIOR */
  }
  else
  /*----- File Spec. for creating a S/AM file -----*/
  /* Note: #2 are to be replaced by actual filenames */
  strcpy(createfilespec, "FILENAME=#2; ENCRYPT= AUTO; PW=byppassword");
  KEYFIELDS=2; PARTNAME(2)=NAME; PH(1)=54;
  PARTIES(2)=A; PT(1)=8;
  PARTLEN(2)=VAR; PL(1)=9;
  PARTORDER(2)=ASC; PD(1)=ASC;
  DATAFIELDS=2; DATANAME(1)=DIVISION; DATATYPE(1)=A; DATALEN(1)=10;
  SW(2)=WMOODY; DT(2)=-9; DL(2)=-8;
  CREATE(REPLACE(createfilespec, "#2", salesfile)) /* S/AM */
  PRINTF("... Created %s.\n", salesfile) /* SUPERIOR */
}
/*** End of MAIN *****/
```

UserSoft/C is the Business C

UserSoft Business C is the financial C compiler that makes sense to both clients and programmers. It is *not just another C compiler*.

Business C Development Tools™, consists of SCREEN™, S/AM™ and SUPERIOR™, regular price at US\$299.95. **Comdex '88 special at US\$199.95.** System Requirements for the IBM PS/2™ and the IBM® family of personal computers and all 100% compatibles. PC-DOS (MS-DOS) 2.0 or later. 384K RAM. **Compiler Library Models** SMALL to HUGE.

Commercial C Development Tools™, consists of S/AM™ and SUPERIOR™, regular price range from US\$499.95 to US\$999. **Comdex '88 special at US\$399.95.** Commercial Development Tools are currently available for UNIX (Sun, VAX), and other systems. Versions for Macintosh™, IBM/VS™ and XENIX™ will be released early in 1989.

S/AM—the revolutionary database management system that gives you **unlimited growth and ease of usage**. There are no limitations on any of the following features: key types (alpha-numeric, integer, float & image), # of key parts, # of data fields, size of any key and/or data, and # of alternative keys. Other features include automatic management of alternative key files (virtual tables); encryption on file, record, datafield or even a byte; privacy prevention option (in the event of three or more illegal attempts to access the file, future access to that level will be prohibited until reset); high-language access for non-image data; mixed (fixed and variable) data field/key length for storage compression & for special applications.

SCREEN is a superset of UNIX curses; supports large window buffer with scroll, wrap, horizontal scroll etc.; has multiple windows & sub-windows, direct screen read/write and auto CGA/monochrome capabilities. Optimized for developing spreadsheet and word processing programs.

SUPERIOR—the world's first breakthrough in making C "The language for developing business application programs". It is capable to manipulate the format for inputting or outputting values with just one statement which could not be done by any of the other languages from BASIC, conventional C, COBOL, FORTRAN, SNOBOL to 4GL. It includes functions for strings manipulation, conversion, business calculation such as regression, standard deviation, **innovative** complex matrix operations, and most built-in functions compatible to those of WANG™ BASIC/2, IBM™ PL/1 subset G and THEOS™ BASIC.

See the **September/October issue of BYTE**, a detailed comparison of the functions, portability, documentation, product and price in detail.

Why do project managers buy? UserSoft's Tools minimize training costs, increase productivity, reduce stress and development time; and eliminate complexities of project through "programming compression", also provides privacy to information.

Why do COBOL programmers buy? It has superpowerful routines for screen handling, flexible and unique input/output formatting, easy-to-use BASIC and PL1 functions. It, increases project performance and software portability, makes C easier to use than COBOL & other languages.

Why do C programmers buy? It reduces coding, debugging, testing and programme maintenance time. It provides easy portability and conversion to other systems. It is the most complete, powerful and flexible set of tools ever required for software development.

Why do educational institutes buy? It is the world's most versatile Data Management system yet practical and easy to be taught. UserSoft Development Tool is the possible replacement of COBOL, PL/1, FORTRAN, BASIC. It prepares student to be highly productive and competitive in the industry.

Can you afford to wait? Many with no computer experience have already claimed to have **acquired C programming skills in just one week.** Business C Development Tools™ could make you more competitive increasing productivity manyfolds.

This special offer **must be posted before November 19, 1988.**
YES... Please Rush me _____ copies of the following products.
Business C Development Tool ■ US\$199.95 (includes S/AM, SUPERIOR and SCREEN—PC/XT/AT only)
Commercial C Development Tool (includes S/AM and SUPERIOR)
For non-PC product please call (800) 663-0322
UNIX (reg. \$499-\$1999) ■ **US\$399.95**
 Apollo Honeywell Sun VAX
 UNISYS Wang/INEX
WANG/___VS (reg. \$1499) ■ **US\$399.95**
OTHER (reg. \$999-\$1999) ■ **US\$999.95**
 VMS MVS PRIMOS VS/VS1
Individual Tools for PC only:
 S/AM US\$99.99 SUPERIOR US\$99.99
 SCREEN US\$69.99
Circle for my: MicroSoft-C/Turbo-C/Lattice-C/Advanced-C + / _____
 5 1/4" disk (360k/1.2M) or 3 1/2" disk
I'll like to have more information for _____ system.

NAME _____
ADDRESS _____
CITY/STATE _____
ZIP/PHONE _____
CARD # VISA MASTERCARD AMX CHQ.
EXPIRATION DATE _____

To order Call: 1-800/663-0322
We have changed location at Comdex 88. See us now at the Riviera Hotel, Booth R8630.

Shipping and Handling:
North America (US\$10 UPS; \$20 Air);
Overseas US\$50.

General: (604) 681-8872, or
FAX (604) 685-1207/Telex 04-508312
VCR ATTN USERSOFT

All dealers/wholesalers/educators are welcome, call Mr. S. Chetty (604) 681-8872



USERSOFT

If within 60 days of purchase, this product does not perform in accordance with our claims, call our customer service department and we will arrange a refund.

All UserSoft products are trademarks or registered trademarks of UserSoft Systems Limited. Other brand and product names are trademarks or registered trademarks of their respective holders. Copyright© 1988 UserSoft Systems Limited

UserSoft Systems Limited
Suite 1512, 409 Granville St
Vancouver, BC, Canada V6C 1T2
Telephone 604/681.8872

Power C is a trademark of Mix Software
MS-DOS, Microsoft C is a registered trademark of Microsoft Corporation
Turbo C is a registered trademark of Borland International
IBM, MVS and VSAM are trademarks of International Business Machine
Sun is a trademark of Sun Microsystems
DEC, VMS and VAX are trademarks of Digital Equipment Corporation
UNIX is a trademark of Bell Laboratory
VS is a trademark of WANG Laboratory

New Prices

OS/2

WINDOWS FOR DATA®

MULTI-LEVEL MENU SYSTEM

NESTED POP-UP FORMS

SCROLLABLE REGION

CHOICE LIST

CLOCK

POP-UP WINDOW

RUNNING TOTALS

MESSAGE WINDOW

Invoices: Create Review Print Exit

INVOICE

Invoice No.: 008784 Date: 12/03/87 Time: 16:43:15

Customer: William Jones
Innovative Software
351 Bulletin Avenue
Needham, MA 02194
(617) 394-5512

No.	PRODUCT	DESCRIPTION	QUANTITY	PRICE	AMOUNT
5	WDMS	Windows for Data Microsoft	10	295.00	2950.00
6	WDLA	Windows for Data Lattice	5	295.00	1475.00
7	WDTC	Windows for Data Turbo C	5	295.00	1475.00
8	WDXE	Windows for Data XENIX	2	795.00	1590.00
9			0	0.00	0.00

Subtotal: 11325.00
Shipping: 0.00
TOTAL: 11325.00
Payment: 0.00

Cursor keys scroll, ENTER selects and ESC exits choice menu

If you program in C, take a few moments to learn how Windows for Data can help you build a state-of-the-art user interface.

- ✓ Create and manage menus, data-entry forms, context-sensitive help, and text displays — all within windows.
- ✓ Develop window-based OS/2 programs right now, without the headaches of learning OS/2 screen management. Run the same source code in PC DOS and OS/2 protected mode.
- ✓ Build a better front end for any DBMS that has a C-language interface (most popular ones do).



FROM END TO BEGINNING

Windows for Data begins where other screen packages end, with special features like nested pop-up forms and menus, field entry from lists of choices, scrollable regions for the entry of variable numbers of line items, and an exclusive built-in debugging system.

NO WALLS

If you've been frustrated by the limitations of other screen utilities, don't be discouraged. You won't run into walls with Windows for Data. Our customers repeatedly tell us how they've used our system in ways we never imagined — but which we anticipated by designing Windows for Data for unprecedented adaptability. You will be amazed at what you can do with Windows for Data.

YOU ARE ALWAYS IN CHARGE

Control functions that you write and attach to fields and/or keys can read, compare, validate, and change the data values in all fields of the form. Upon entry or exit from any field, control functions can call up subsidiary forms and menus, change the active field, exit or abort the form, perform almost any task you can imagine.



OUR WINDOWS WILL OPEN DOORS

Our windows will open doors to new markets for your software. High-performance, source-code-compatible versions of Windows for Data are now available for PC DOS, OS/2, XENIX, UNIX, and VMS. PC DOS versions are fully compatible with Microsoft Windows. **No royalties.**

MONEY BACK GUARANTEE

You owe it to yourself and your programs to try Windows for Data. If not satisfied, you can return it for a full refund.

Prices: PC DOS \$295, Source \$295. OS/2 \$395. XENIX \$795. UNIX, VMS, please call.

Call: (802) 848-7731

Telex: 510-601-4160 VC SOFT

ext. 51

FAX 802-848-3502



Vermont Creative Software

21 Elm Ave.
Richford,
VT 05476

*Staff-written highlights of developments
in technology and the microcomputer industry*

Is Software Complexity Slowing the Computer Industry?

The next version of Lotus 1-2-3: late. The forthcoming dBASE IV: late. FullWrite Professional: finally shipped after being famously late. As programs get more feature-bedecked and more powerful, announced shipping dates keep going askew. But there's more to the problem than software houses missing ship dates and users having to wait and wait and the trade press having to write another story about vaporware. Software just isn't keeping up with hardware. While dramatic advances in computer hardware seem almost commonplace, progress in software development is having a hard time keeping up; in fact, it may be going in reverse. Software companies are having more trouble delivering their products, which become increasingly

complex as they offer better performance.

Artificial intelligence is a good example of very complex software, software that's very smart and hence very hard to code. "AI is software," said Dr. Philip London of Cognition, Inc. (Billerica, MA), "and the general pace of software advancement will be slow. There's a big difference between research projects and commercial products." While acknowledging that hardware advancements certainly help software technology, London said that software designers need to learn how to write software for advanced hardware systems, like massively parallel architectures, which he said are poorly understood by software developers.

Big advances are needed

in software productivity, too. "Converting good ideas into software products is extremely difficult," London said. While engineers are learning how to manage complex engineering projects, complex software projects "resist the efforts of traditional management techniques," he added. Programmers also have to follow rules set by hardware engineers. "Software must interface to external, arbitrary specifications."

London cautioned that "no magical solution exists," and he doesn't expect revolutionary advances in software development. The best thing that can be done is to require "discipline and cleanliness" of computer programmers. "The top 5 percent of software engineers produce most of the best code," London said.

NANOBYTES

- Despite all the talk about **erasable optical disks**, such media doesn't scare Paul Schroeder, president of WORM-maker **Maximum Storage** (Colorado Springs, CO). Comparing erasable and nonerasable media is the proverbial apples and oranges, Schroeder says. Erasable is certainly remarkable, but there are some situations in which you don't want the information to be susceptible to obliteration, deliberate or accidental, he points out. Permanent archives is where WORM (write once, read many times) technology shines. "Let's not put write-once in the hands of someone who needs a Winchester," says Schroeder. "That's dumb." Maximum recently brought out its APX-4000 optical disk subsystem, which puts 500 permanent megabytes on a 5¼-inch cartridge.

- **Apple** (Cupertino, CA) said at SIGGRAPH that it will be shipping **X-Windows software** to go with A/UX by the end of the year. The kit will include X-Windows execution software, display managers, and both end-user and programmer documentation.

- If you think you see a **difference in picture quality** between comparable color monitors from different companies, look closer or call a doctor. These days, a select few manufacturers make

continued

Zenith Implements Multiprocessing in AT-Compatible Unix System; New Bus Links Cards

Zenith Data Systems (Glenview, IL) has implemented multiprocessing in a new Unix-running IBM-compatible machine that can be charged with as many as six Intel 80386 processors and can handle as many as 64 users. The multiprocessor technology consists of both hardware and software innovations. The hardware component centers on a new proprietary multiprocessing bus. The software component consists of a modified Xenix operating system. BYTE was given an early look at a hand-built production prototype of Zenith's first high-end sys-

tem, called the Z-1000.

The Z-1000, housed in a castored case about the size of a one-drawer filing cabinet, is a dual-bus computer: one bus for the CPUs and memory, and one bus for peripherals. The peripherals bus is a standard 20-MHz PC AT bus, which allows the machine to work with the variety of low-cost peripherals available for the AT. Connecting the two buses is a "bridge card" that contains another 80386 CPU. This CPU actually supports the operation of Xenix and serves as the communications path for the CPU cards on their dedicated bus and the

peripherals on the AT bus.

The system designers decided not to use IBM's Micro Channel bus because it would not operate reliably at the speeds required of the Z-1000, an engineer said.

The Z-1000's CPU bus, called the C-Bus, is electronically similar to the NuBus in the Apple Macintosh and Texas Instruments 1500 but uses different connectors, Zenith engineers said. The CPU cards use this bus to communicate with each other and with the Z-1000's fast 32-bit memory. The machine can take as many as five of these CPU cards,

continued

NANOBYTES

the color picture tubes for all those different brand names, says Amnon Rosen of monitor-vendor Relisys. So chances are the monitor made by Company X has the same picture tube as the monitor made by Company Z. Three companies in the Far East make everybody's tubes except Zenith's, he says. Zenith makes its own. Rosen says he likes to set up a Relisys multiscan monitor next to an NEC multiscan monitor and ask people which monitor is better. "People tell us they don't think our picture is any better," he says. "Of course not—our picture tubes come from NEC."

• The biggest barrier to using computers in Japanese schools is a **shortage of computers**, according to a report released by Japan's Computer Education Development Center. About half of the schools surveyed said a lack of computers, insufficient funds for buying software, and a shortage of teachers who can develop computer-based programs are holding back computer use in education. About 50 percent of the high schools surveyed teach programming classes, particularly BASIC, Logo, FORTRAN, and COBOL.

• While neural networks are still largely in the realm of exotica, several companies are **mixing neural networks and image processing**, according to reports from a recent conference. An official of Nestor (Providence, RI) said firms have integrated the neural-based **Nestor Development**

continued

which are used to support remote users. The cards, C-Bus, and modified Xenix kernel were developed by Corollary, Inc. (Irvine, CA), in cooperation with Zenith.

According to George P. White, president of Corollary, the new C-Bus has an advantage over the NuBus because it supports "cache coherency." Cache coherency ensures that the contents of each 80386 processor's memory cache are updated correctly. The C-bus is also significantly faster, running at 16 MHz versus the 10 MHz of the NuBus. The difficulties of promoting a new, proprietary bus can be avoided if the bus can be linked to a standard bus, White said. Thus, Corollary developed the bridge card that connects to both the C-Bus and the AT bus.

Each CPU card will support four serial ports, and each serial port will work with a concentrator to support eight serial devices.

The Z-1000 will support a total of 160 serial devices, but the practical upper limit for users is 64, a spokesperson said. In all, 20 expansion slots are available on the Z-1000's backplane. The design for the backplane was developed from the similar structure in the Zenith Z-248, one engineer said.

The base model of the Z-1000 will sell for about \$19,000, a company official said. Zenith credits the relatively low price to basing the machine on readily available personal computer components. The Z-1000 is meant to work with any drive that uses a SCSI hookup. The drives are removable; they mount in carriers that slide into the machine and attach to a matching connector in the rear of the bay. The drive bays will hold full-height 5¼-inch disk, tape, or optical disk drives.

One disadvantage of multiprocessing systems is that they spend a lot of time

coordinating the various processors compared to the time spent doing real work. When asked about the processing overhead of the Corollary system, White said that it depends on how you test it. In one test using four 80386 processors, the system performed three times faster than a system with one processor.

The new technology could give Zenith a significant advantage over competing manufacturers (e.g., TI with its 68020-based 1500), especially in the government and Unix markets. One advantage of the Zenith system is that it could use 16-MHz 80386 processors rather than expensive and scarce 20- and 25-MHz chips. Also, the 80386 chips allow for DOS compatibility. Theoretically, DOS applications can be run under Xenix and thus take advantage of the high speed offered by the multiprocessing capabilities.

Database Servers Seen as Key to Unix Success

Unix might never overtake DOS or the Macintosh Finder as the leading operating system for personal computers, but it could do very well as an operating system for database servers in networks connected to PCs. Leading Unix database developers predict that the powerful operating system will become more important in the commercial database market.

A new database market is emerging in which high-end Unix-based computers act as database servers for client machines running MS-DOS, OS/2, or the Macintosh OS, said Mark Hoffman, president of Sybase (Berkeley, CA). In this model, the large relational database operates on the Unix server, while connected personal computers run a graphics-based interface for

accessing and updating the server's database. One of the advantages of the client/server model, said Hoffman, is that you can upgrade and update the server without making any changes to the client systems. Hoffman predicted that Unix will compete favorably with OS/2 at the low end and VMS at the high end as the operating system of choice for database networks.

Informix (Lenexa, KS) chairman Roger Sippl agreed that personal computers are "taking over the desktop from character-based terminals" and will provide "novice user interfaces" to get output from database servers.

Unix-based database servers also threaten the domain of the corporate mainframe. According to Larry Ellison, CEO at Oracle

(Belmont, CA), "We can perform 120 transactions per second on a \$1 million [Unix] machine versus 256 transactions per second on a \$10 million IBM mainframe. Unix is fast approaching mainframe performance."

However, there are some major problems to be solved before Unix systems will displace corporate mainframes. Probably the most difficult task is providing transparent access to non-relational databases from the Unix relational database server. As Gary Morgenthaler of Relational Technology (Alameda, CA) pointed out, most of the existing data on corporate mainframes is not in relational format.

The Open Systems Interconnect (OSI) committee is

continued

The Bus Stops Here!

Introducing Wells American's CompuStar® Multi-Bus Business Computers.
The world's first and only multi-processor, convertible bus™ microcomputers.

Ask any computer expert about what type of system you should buy nowadays and you'll likely get a "pass the bus" response. Something like — "Well, uh, the PC/AT* bus is your best buy but, then again, the new PS/2* bus may become the next industry standard." Great advice, right? If trying to decide on a processor weren't tough enough, now you're expected to pick a bus, too.

RELAX, NOW THERE'S COMPUSTAR.®

The all new CompuStar® from Wells American not only lets you interchange microprocessors, you can also mix and match buses — a PC/AT bus, a PS/2 bus or... both. As your computing needs change, simply snap in a new processor or add an extra bus. You'll never again have to worry about buying the *wrong* computer system!

FOUR COMPLETE SYSTEMS IN ONE.

The CompuStar can be configured with any of four microprocessors — an 8086, an 80286, an 80386SX, or an 80386. The processor and up to 16 megabytes of user memory have all been combined, using the latest VLSI technology, on a single, plug-in CPU module. Plus, any time during the first year of ownership, CompuStar users can "trade-in" the CPU module they initially selected toward the purchase of any of the other more powerful modules. *Nobody* but Wells American gives you this kind of value.

CONVERTIBLE BUS? YOU'RE KIDDING!

No, we're not. In fact, it may well be the most practical microcomputer innovation ever. Say you've selected an AT compatible CompuStar and later want to add PS/2 compatibility. No problem! Snap in a PS/2 Bus and Adapter Module and you can use *both* buses in the same system. Likewise, if you've selected a PS/2 compatible CompuStar and decide you want to add an AT bus, just snap in an AT Bus Module. Depending on configuration, the CompuStar can have up to 13 bus expansion slots — all AT slots, all PS/2 slots or a "split-bus" of AT and PS/2 slots. Best of all, you can reconfigure your CompuStar whenever you want.

\$1995



The CompuStar is also easily expanded. That's because there are seven CompuStar disk/tape compartments — six accessible from the front and an additional full-height bay inside. All this in a sleek, compact tower design that actually leaves *more* room on your desktop than any of the so-called "desktop" models.

A NEW IDEA FROM AN OLD COMPANY.

The CompuStar® Multi-Processor, Convertible Bus™ Microcomputer. It's no surprise that our engineers invented it. After all, we've been making microcomputers longer than anyone else... even longer than IBM! And if that kind of experience doesn't impress you, CompuStar's service programs surely will. You can select an optional overnight module swap-out plan or on-site service from General Electric Corporation — one of the most respected names in consumer electronics. And, of course, every CompuStar carries a full one-year factory warranty.

FINALLY, AFFORDABLE TECHNOLOGY.

Think all this technology sounds expensive? It's not. CompuStar 20MHz 80286 systems start as low as \$1995†. There are also inexpensive 8086 and powerhouse 25MHz 80386 systems available. Plus, there is a wide variety of CompuStar display, tape and disk options including a one gigabyte erasable optical disk. You can choose a factory preconfigured CompuStar or custom design one yourself. Just unlock the front panel and literally "snap-in" a bus, CPU or disk module in a matter of seconds. It's system flexibility never before available... at any price.

While one of our competitors (we won't mention any names) threatens you with "missing the bus," most simply *pass* the bus. Our new CompuStar however, *eliminates* the bus problem altogether. Not to mention the processor problem. Even the expansion problem. Prove it to yourself. Call today about our CompuStar 31-day trial offer. Oh, and by the way, the next time anyone asks, tell 'em you know where the bus stops.



Corporate Headquarters: 3243 Sunset Boulevard • West Columbia, SC 29169 • 803/796-7800 • TWX510-601-2645

*Personal Computer AT, AT and PS/2 are trademarks of International Business Machines Corporation. †Photograph depicts optional equipment. Complete price list available upon request. CompuStar 80286 base system (\$1995) includes built-in VGA/EGA display adapter, one diskette drive with controller, two serial/one parallel/one mouse port, keyboard and 220 watt power supply.

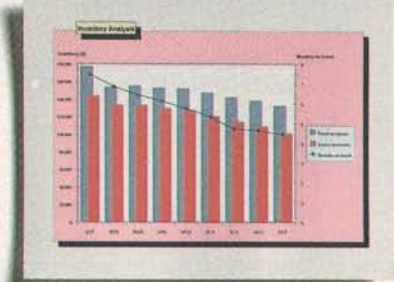
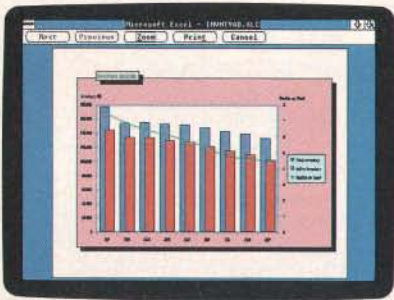

Don't waste any more time, or paper. Preview your ideas before you print them out.

As you can see, Microsoft can make all kinds of HP printers and plotters look their best.



Personalize your LaserJet Series II Printer with HP fonts and memory boards.

These documents were brought to you by Microsoft Excel, Microsoft Windows, and the HP LaserJet Series II, PaintJet and DeskJet printers.



Personal Stock Portfolio

Client: Larry S. Stevens		Date: 5/26/1988
Business Address: 1234 Cherry St. Coventry, WA 98000		Home Address: 2713 Elm Blvd. Coventry, WA 98000
Telephone: (206) 555-2300		Telephone: (206) 726-4995

Stock	Symbol	5/23/88	5/23/88	5/23/88
Emchment Lakes	EL	19,230	73,200	76,125
Tree Research	TR	49,632	48,375	48,875
Trans-Com	TCM	13,875	13,750	14,250
Major Software	MSW	26,500	30,000	28,675
WaveWorks	WW	24,750	44,250	45,575
Total/Avrg		\$23,856.48	\$24,772.24	\$26,863.88

Stock	Holdings	Current Quote	Current Value
Emchment Lakes	100	76.125	\$7,612.50
Tree Research	125	48.875	\$6,109.38
Trans-Com	125	14.250	\$1,781.25
Major Software	11	26.075	\$286.83
WaveWorks	175	65.375	\$11,440.92
Portfolio Total:			\$26,863.88

Suite 301, Olympus Building • 123 West Fifth Avenue, Miami FL 33186 • (305) 278-8839

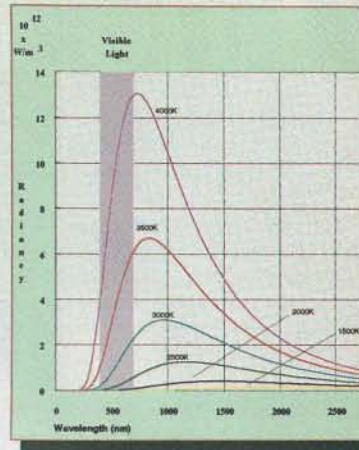

Product Sales Report

By Month Total	Product Sales						Total
	Jul	Aug	Sep	Oct	Nov	Dec	
Units	847	817	1,248	2,002	1,508	1,784	8,206
Actual Sales	974	376	480	347	484	500	3,161
Forecasted Sales	\$46,200	\$40,044	\$114,577	\$148,654	\$116,630	\$100,000	\$627,635
Actual Revenue	\$42,800	\$81,261	\$87,272	\$107,902	\$116,630	\$100,000	\$636,635
Forecasted Revenue	\$114,912	\$1,216	\$17,454	\$62,000	\$800	\$300	\$126,612
Revenue %	117%	100%	100%	117%	107%	100%	100%

Category	Jul	Aug	Sep	Oct	Nov	Dec	Total
Accessories	28	22	41	54	46	31	222
Software	97	27	80	50	68	47	369
Hardware	847	849	1,248	2,002	1,508	1,784	8,206
Other	640	640	879	847	847	847	5,047
Forecasted Revenue	\$7,100	\$4,000	\$10,000	\$12,000	\$12,000	\$12,000	\$63,100
Revenue %	117%	100%	100%	117%	107%	100%	100%

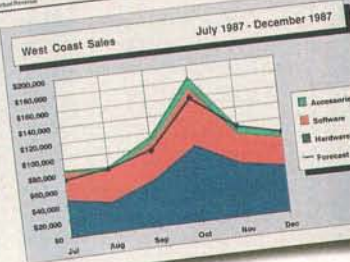

West Coast Sales

Consolidated Balance Statement

Assets	1988	1987
Current Assets		
Cash and Short-term Investments	\$12,546	\$107,544
Accounts Receivable	\$36,878	\$36,799
Inventory	\$18,250	\$12,000
Other	\$1,564	\$6,982
Total Current Assets	\$79,238	\$163,325
Property, Plant, and Equipment	\$81,230	\$50,480
Other Assets	\$4,637	\$3,317
TOTAL ASSETS	\$165,105	\$217,122
Liabilities and Stockholder's Equity		
Current Liability		
Accounts Payable	\$19,584	\$(33,134)
Customer Deposits and Deferred Revenue	\$6,547	\$5,989
Regulatory and Commission Payable	\$1,237	\$4,203
Accrued Compensation and Payroll Liabilities	\$1,124	\$1,836
Notes Payable	\$2,075	\$4,000
Income Taxes Payable	\$3,285	\$3,284
Other	\$7,125	\$1,578
Total Current Liabilities	\$40,981	\$27,700
Capital Lease Obligations	\$1,014	\$1,363
Commitments and Contingencies	\$5,848	\$4,777
Total Liabilities	\$47,843	\$33,840
Stockholder's Equity		
Common Stock	\$56	\$37
Paid in Capital	\$76,654	\$26,630
Retained Earnings	\$40,235	\$142,000
Translation Adjustment	\$1,230	\$801
Total Stockholder's Equity	\$117,262	\$183,281
TOTAL LIABILITIES AND STOCKHOLDER'S EQUITY	\$165,105	\$217,122

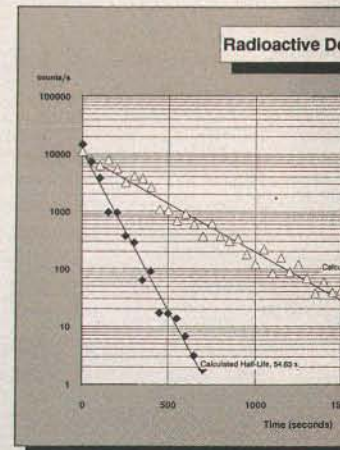

Two world leaders develop highly explosive material.

Hewlett-Packard and Microsoft just took the simple act of communication and turned it into something a bit more powerful.

Illumination. Because to us, anything worth presenting in a spreadsheet

is worth presenting more clearly, more concisely, and more forcefully. Which is exactly what Microsoft® Excel and the Hewlett-Packard® LaserJet Series II® printer let you do.

With this powerful combination of software and printer, now it's easier to take common data and make it look anything but common. With incredibly flexible font styles, font sizes, borders and shading. Incorporated into spreadsheets, charts, tables and forms that instantly make your data say more. Your numbers add up to more. Your

facts, figures and ideas mean more.

And of course, HP® desktop plotters and printers, from the ColorPro® plotter to the PaintJet®, DeskJet™ and LaserJet Series II printers, can unleash the potential power inside every box of Microsoft Excel. And vice versa.

To witness a whole new world of spreadsheet output, call us at (800) 541-1261, Dept. 156 for a free copy of our booklet, "Of Power And Printers." Or simply go to your dealer. And see firsthand what happens when two explosive elements get together.

And the chemistry's just right.



HP LaserJet Series II Printer

Microsoft®

©1988 Microsoft Corporation. Microsoft and the Microsoft logo are registered trademarks of the Microsoft Corporation. Hewlett-Packard, ColorPro, PaintJet and LaserJet Series II are registered trademarks, and DeskJet is a trademark of Hewlett-Packard Company. Customers in Canada call 1-416-873-9811, outside of North America, 1-206-882-8661. Offer good in United States only.

NANOBYTES

System and the **Datacube** (Peabody, MA) **MaxVision** image-processing workstation to build an "intelligent" system that will learn, from examples, to recognize objects, characters, and other images. Adaptive pattern-recognition techniques enable the system to correctly identify objects in situations where other systems fail, Nestor says.

- A proposed massive cut in the budget for the **Ada Technology Insertion Program**, planned as part of the Department of Defense budget slash for next year, has some Ada proponents concerned. The program, which is set to be cut from \$13 million to \$1 million, makes grants to companies that might help establish Ada as a standard programming language. But an exec with Alsys (Waltham, MA), one of the major Ada houses, isn't worried. Most of the funding has been used to get people to switch from COBOL to Ada, said vice president Jerry Rudisin, and it's now too late to stop Ada's momentum, he said. Ada is "already making inroads into the classic COBOL world. It's being used to write database systems and banking applications," he said. Alsys recently signed a deal to develop Ada compilers for the INMOS transputer.

- The European Community Commission, the administrative arm of the Common Market, has recommended a special category of copyrights for computer software that would protect programs from copying or translation for 25 years after

continued

working on remote database transfer protocols for nonrelational databases, such as IMS, BSAM, and RMS, Morgenthaler said. "Half the world's data is in IMS databases," he said. "The real challenge is not connectivity to SQL data, but providing gateways to older, nonrelational databases."

Another problem facing

Unix is the lack of software applications, said Oracle's Ellison. "Application development tools are not enough," he said. "Unix is rich in DBMS software, but very poor in applications like electronic mail and basic accounting software." Ellison said application software is essential to the success of Unix. However, others are skeptical that com-

panies specializing in database applications could provide the necessary office automation applications. Ellison countered that "E-mail is fundamentally a relational database problem. People want to transmit objects from databases," he said. However, Sippl argued that word processing and spreadsheets are also key applications.

"Floptical" Drive Matches Hard Disk Capacity and Price

Thinking about a 20-megabyte hard disk drive? Maybe you should think again. Insite Peripherals (Santa Clara, CA) claims you'll soon be able to get the same capacity on a floppy disk drive—and at the same price. The company hopes to start selling its Floptical disk drive, designed to combine the advantages of optical storage and magnetic floppy-disk technologies, early next year.

Insite's Jim Adkisson, who worked on the original 5¼-inch floppy disk while at Shugart Associates, says floppy disk technology has been stagnant ever since Japanese companies took over that market in the early 1980s. "We're not exactly trying to take on Japan," he told *Microbytes Daily*, "but we're bringing back the technology leadership."

The Insite I325 drive will be a plug-and-play substitute for a SCSI-equipped Seagate 225 hard drive, Adkisson said. The difference is that the Insite drive uses removable 3½-inch disks

that are like IBM's 2-megabyte floppy disks but with optical tracking guides engraved on the disks by laser, pushing the capacity to just over 20 megabytes.

Magnetic floppy disks have a much higher inherent capacity than current floppy disk drives offer. The problem, according to Adkisson, is floppy disk instability: a typical floppy disk has a lot of wobble, which makes it tough for the magnetic heads to track the data on the disk, which thus limits track densities. (A conventional 3½-inch floppy disk has only 135 tracks per inch; an optical disk drive, which uses much more stable media, can have as many as 15,000 tracks per inch.)

Insite's drives solve the wobble problem by tracking the laser-etched track markers with a closed-loop optical servo system. Since the tracks are laser-etched, they can't be accidentally erased—and, unlike some high-capacity floppies, the tracks are soft-formatted, so

the disks aren't limited to one kind of magnetic encoding. But Insite says its big breakthrough is the low cost of the tracking head—using an infrared LED instead of a laser to follow the tracks, the head carriage assembly is much less expensive than any of its competitors (about the same as a 20-megabyte hard disk, the company says).

The company designed the drive, Adkisson said, to have the same average seek time (65 milliseconds), capacity (20 megabytes), and price as a SCSI-equipped Seagate 225. His plan is to compete head-to-head with 20-megabyte hard disk drives.

Insite has already signed up Kodak and Xidex to manufacture the 1250-track-per-inch (tpi) floppy disks (for about \$8 each), Adkisson said. The company plans to initially sell the drives to OEMs. Quantity prices are "expected to be under \$250," Adkisson said, but the final price will depend on the price of the Seagate 225.

Silicon Graphics Brings Down Cost of 3-D Graphics

Real-time, three-dimensional graphics has been the domain of high-priced machines costing \$50,000 and up. Repainting three-dimensional images on the screen 20 or 30 times per

second takes a lot of computational power and also some very sophisticated graphics processing hardware.

However, the price of three-dimensional graphics is

dropping, as indicated by systems like the new Personal IRIS workstation from Silicon Graphics (Mountain View, CA). The Unix-based Personal IRIS

continued

TAKE THE THREE-VOLUME C PROGRAMMER'S LIBRARY

A \$74.85 value—Yours for only \$49.95

as your introduction to the **Library of Computer and Information Sciences**.

Keep up with the ANSI standard, apply undocumented tips, tricks, and shortcuts. Take advantage of the powerful advanced concepts with the **C PROGRAMMER'S LIBRARY**.

You never have to buy another book!

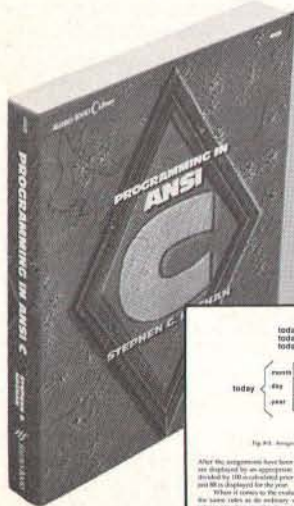

```

today.month = 0;
today.day = 25;
today.year = 1988;
    
```

month	0
day	25
year	1988

Fig. 8-3. Assigning values to an array variable.

After the assignment has been made, the values contained inside the structure are displayed by an appropriate printf call. The members of today are divided by 100 and rounded prior to being passed to the printf function so that only 00 is displayed for the year.

When it comes to the evaluation of expressions, memory variables follow the same rules as the ordinary variables in the C language. In the division of a integer structure member by another integer variable, the result is an integer division, as in:

```

today.year / 100 = 19;
    
```

Suppose we wanted to write a simple program that accepted an input date and displayed to the user tomorrow's date? From an input date, the user's date and year are stored in separate variables. We can use the user's date and year and use them to calculate tomorrow's date by a series of relatively simple calls.

```

tomorrow.month = today.month;
tomorrow.day = today.day + 1;
tomorrow.year = today.year;
    
```

Of course, the above statements would work just fine for the majority of dates, but the following two cases would not be properly handled:

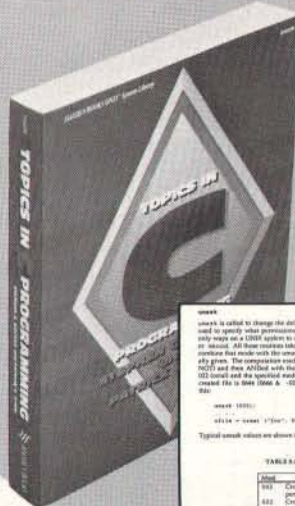

```

memset(
where it is called to change the default file creation mode, or memset. The result is used to specify what permissions will not be set on what a file is created. The only way on a UNIX system to create a file through a call to open, create, or mkdir. All these routines take a mode string of their arguments and they all combine that mode with the mode to determine the permissions the file is actually given. The comparison mode is fairly simple: the mode is treated like a 16-bit and then shifted with the special mode. For example, if the mode is 066 and the special mode is 000, then the resulting mode of the newly created file is 066 && 000 = 000. The corresponding C statement would be:
memset(
mode = 066;
mode = mode & 000;
    
```

Typical mode values are shown in Table 5-2.

Mode	Description
000	Create file without write permission to others
002	Create file without write permission to group or others
006	Create file without read or write permission to others and without write to group
007	Create file without read, write, or execute to others
003	Create file without read, write, or execute to others and without write to group
011	Create file without read, write, or execute to group but the owner

See also the file mode values in the following statement printed out by the user:

```

printf("mode = %d", mode, 001);
    
```

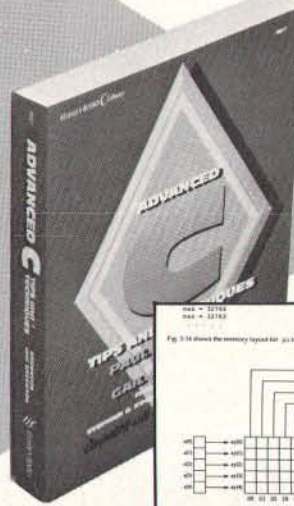

```

row = 22;
col = 12;
    
```

Fig. 3-10 shows the memory layout for a 2D array in the data area.

Fig. 3-10. Two-dimensional array memory.

We show only the portion from a to c, and only the first row of a (a[0][0] to a[0][11]). The array addresses a[0] is a pointer to the first row of a two-dimensional array of pointers to integers. a[0][0] is a pointer to the first integer in the first row of the two-dimensional array. a[0][11] is a pointer to the last integer in the first row of the two-dimensional array. The original value of a becomes an array of pointers to integers. Note that the three-dimensional array is a pointer to a pointer to a pointer. The first row of the three-dimensional array is a pointer to a pointer to a pointer. If you pass the three-dimensional array to a function or address it with a global statement, you'll have to modify the declaration: void main(int argc, char **argv) { ... }

PROGRAMMING IN ANSI C

Stephen G. Kochan.

This revised edition of Kochan's highly acclaimed *Programming in C* focuses on the newly established ANSI standard. Learn how to write, compile, and execute programs in C. Includes 90 complete programs, each one with fully documented source codes, and step-by-step explanations. Publisher's price: \$24.95

TOPICS IN C PROGRAMMING

Stephen G. Kochan and Patrick H. Wood.

Beginning with structures and pointers, this advanced-level book provides you with a complete, detailed explanation of the most difficult concepts in C programming. Filled with working programs and end-of-chapter exercises, it explores character testing, string handling, encryption, table and tree manipulation, random number generation, and a range of other functions. Publisher's price: \$24.95

ADVANCED C: TIPS AND TECHNIQUES

Paul Anderson and Gail Anderson

This how-to guide details hundreds of previously undocumented tricks for creating powerful, portable C programs in all environments. Rather than illustrating how to port techniques from other languages, the authors develop techniques which take advantage of the strengths and quirks of the C language. Publisher's price: \$24.95

THE LIBRARY OF COMPUTER AND INFORMATION SCIENCES is the oldest, largest book club especially designed for computer professionals. In the incredibly fast-moving world of data processing, where up-to-the-moment knowledge is essential, we make it easy to keep totally informed on all areas of the information sciences. What's more, our selections offer you discounts of up to 30% or more off publisher's prices.

4 Good Reasons to Join

- The Finest Books.** Of the hundreds of books submitted to us each year, only the very finest are selected and offered. Moreover, our books are always of equal quality to publishers' editions, never economy editions.
- Big Savings.** In addition to getting the C Programmer's Library for only \$49.95 when you join, you keep saving substantially, up to 30% and occasionally even more. (For example, your total savings as a trial member—including this introductory offer—can easily be over 50%. That's like getting every other book free!)
- Bonus Books.** Also, you will immediately become eligible to participate in our Bonus Book Plan, with savings of 65% off the publishers' prices.

4. Convenient Service. At 3-4 week intervals (16 times per year), you will receive the Library of Computer and Information Sciences News, describing the Main Selection and Alternate Selections, together with a dated reply card. If you want the Main Selection, do nothing, and it will be sent to you automatically. If you prefer another selection, or no book at all, simply indicate your choice on the card and return it by the date specified. You will have at least 10 days to decide. If, because of late mail delivery of the News, you should receive a book you do not want, we guarantee return postage.

If reply card is missing, please write to The Library of Computer and Information Sciences, Dept. 7-FB8-00919, Riverside, NJ, 08075, for membership information and an application.

Byte 11/88

NANOBYTES

they are created. The group also proposed protection, in the form of "exclusive rights," for semiconductor designs.

In other news from the Continent, the ECC has accused **Japanese computer printer makers** of selling their wares at unfairly low prices. According to the commission, Japanese vendors dominate the printer scene, with as much as 75 percent of the dot-matrix market. The group wants punitive tariffs of about 40 percent.

• **Cirrus Logic** (Milpitas, CA) has two new chips designed to increase the speed and decrease the cost of **laser**

continued

starts at about \$20,000, which includes a 32-bit reduced-instruction-set-computer (RISC) processor, 8 megabytes of dynamic memory, 8 megabytes of video memory, a 170-megabyte hard disk drive, and a 19-inch, 1280-pixel by 1024-pixel color monitor. That price might sound steep, but if you examine the machine's capabilities and consider outfitting a PS/2 Model 80 or a Mac II with similar memory and storage capacities, the Personal IRIS may be a viable alternative for mechanical and graphics designers.

In addition to Unix and the third-party applications available for other Silicon Graphics workstations, the new IRIS can run MS-DOS applications using Insignia Solutions' SoftPC software emulator.

The heart of the Personal

IRIS consists of a million-instruction-per-second (MIPS) R2000 32-bit RISC processor running at 12.5 MHz and coupled to a Silicon Graphics proprietary Geometry Engine graphics processor. The graphics processor and CPU fit on single boards and are connected back-to-back. Silicon Graphics engineers claim that new application-specific integrated circuit designs allowed them to fit on one board what used to take up four boards. The system has an 8K-byte data cache and a 16K-byte instruction cache. Silicon Graphics claims a performance of 10 VAX MIPS for its CPU (about three times the performance of most 80386 systems). The Personal IRIS I/O bus runs asynchronously to the CPU bus at 10 MHz. According to Silicon Graphics engineers, this design allows

upgrading to higher-clock-speed versions of the MIPS processor without affecting the rest of the system.

The system has an Ethernet port, two RS-232C ports, one Centronics port, one SCSI port, an audio port, and a single VME-bus slot. Two half-height slots are available for a second hard disk drive or a tape drive. (Silicon Graphics is working on an internal floppy disk drive.) The floppy connects to the SCSI interface and can read and write MS-DOS 5 1/4-inch disks. The system comes with a high-resolution optical mouse and pad as well as a 101-key keyboard.

The entry-level model provides 8 color bit planes and 4 bit planes for window management, overlay and underlay, and pop-up menus.

A "super" version of the Personal IRIS features 24-

continued

Ever Really See Your Data?



"I'm discovering patterns and trends I never knew existed in my dBASE records."

"I optimized my sales territories with MapInfo's automatic shading capability."

"I can't believe I got all this power on my PC."



"I never used maps before. Now I can't do without them."

"MapInfo finds addresses and helps me with dispatching."

"The variety of maps available from MapInfo Corp. is outstanding."



"The menus make it virtually effortless."

"With MapCode™, I'm creating custom applications that link databases with maps."

"Now for the first time, I can manage my databases visually."

You can with MapInfo 3.0!

MapInfo answers the question "Where?" From street level to **world-wide**, MapInfo allows you to play visual "What if?" You'll be amazed by how much more valuable your data becomes when you see it on a map.

You can easily locate addresses on our street maps. Or, take it further—draw boundaries, search within territories, determine spatial relationships—and see patterns and trends materialize before your eyes. Use your existing files (in dBASE or ASCII), or create new ones in MapInfo. Analyze your sales territories, optimize deliveries, canvass areas, plan cable routes, identify new markets, track the competition, plan for land use, zoning, roadwork. So much more.

Over 85% of all databases contain location information. With MapInfo, this data comes to life before your eyes.

Order your copy today.

To Order, call 1-518-274-8673 or 1-800-FASTMAP toll free. FAX 1-518-274-0510

*MapInfo costs \$750. Maps for hundreds of metropolitan areas across the U.S., complete with street names and addresses are also available starting from \$250. MapCode programming language—plus maps of counties, ZIP codes, highways, every town, and the world—available separately, starting at \$95.

MapInfo runs on an IBM PC or compatible with 640K memory, a hard disk, and graphics. MapInfo and MapCode are trademarks of MapInfo Corp. IBM is a trademark of International Business Machines Corp. dBASE is a trademark of Ashton-Tate.

See us at
COMDEX/Fall

MapInfo Corp.

200 Broadway
Troy, N.Y. 12180

**Desktop Mapping
For The Masses™**

Circle 206 on Reader Service Card

R E L I A N T

BACK-UP



Only Sysgen tape backup systems are so reliable we'll back up your data with dollars. Here's how:

Two Year Data Loss Recovery Contract.

Can you really trust your backup if a failure occurs?

Yes—if you're using Sysgen™ Reliant streaming tape backup for your PC/XT™/AT™ and PS/2™ systems. Only Reliant offers you *added assurance* against data loss. We'll guarantee you this: if you're unable to retrieve your data from a Reliant tape, we'll pay your data recovery costs up to \$1500 if you're under our Data Loss Recovery Contract* (2 years: \$50, 1 year: \$25). No other tape backup manufacturer offers you this extra protection.

Sysgen's rugged design and excellent price/performance will give you peace of mind—and to give you maximum flexibility, all Reliant backups are available in both external and internal versions.

But RELIABILITY is what backup—and Sysgen—are ultimately all about.

Series 300: Streaming backup on industry standard 1/4" cartridge.

Systems are available at 60 and 125 MB capacity levels. Menu-driven software includes Reliant's exclusive *Autoverify* feature. Comprehensive backup features for Novell®, IBM®, and 3COM® make Series 300 ideal for network use.



Series 200: Cost-effective streaming backup on digital cassette.

Series 200 offers 60 MB capacity in a small 6" x 8" footprint. Data is stored on a compact cassette—you'll never struggle with a pile of floppy disks again. You can pre-set your backup times for automatic operation, while fast 5 MB per minute performance assures your



data will be secure—at your convenience.

Series 500: Latest technology 72 MB streaming backup in a 3 1/2" drive.

Advanced features make Series 500 compact, fast and quiet. The external system has a small footprint and is truly portable. The internal system fits perfectly into the 3 1/2" drive slot of the PS/2. Series 500's unique servo-tracking head mechanism ensures reliable tape interchange between PC and PS/2 configurations.



Back up Your Data With Dollars. Call the Sysgen Hotline for the name of your nearest dealer: 1-800-821-2151.

SYSGEN
INCORPORATED
556 Gibraltar Drive, Milpitas, CA 95035

*All claims subject to the terms and conditions set forth in the Sysgen Data Loss Recovery Contract. Sysgen is a trademark of Sysgen, Inc. XT, AT, PS/2 are trademarks of IBM Corp. IBM, Novell and 3COM are registered trademarks.

NANOBYTES

printer controller boards. The very-large-scale-integration coprocessors, called the Raster Printer Accelerator CL-GP315 and CL-GP340, will work with the Motorola 68000 and other processors used in laser printers; they can be used on a board in the printer or on an add-in card in the computer. The GP315 is rated at 15 pages per minute; the GP340 is rated at 40 ppm. They speed things up by taking over basic page imaging and page printing tasks, such as shading, pattern filling, and clipping. Page printing parameters are passed to the coprocessors instead of to software subroutines.

color bit planes, 8 bit planes for window management, and an additional 24-bit "Z buffer," which provides automatic hidden-surface removal. The Z-buffer determines the distance from the viewer of each Z-coordinate of the image and computes in hardware the necessary hidden-line and hidden-surface removal. The speed of the Z-buffer is really what makes real-time three-dimensional imaging possible on the Personal IRIS. Without the Z-buffer, you can still have hidden-line

and hidden-surface removal, but it must be computed in software, which is considerably slower.

The workstation runs Silicon Graphics' implementation of Unix System V.3. On top of the operating system, Silicon Graphics provides an icon-based windowing system called 4SIGHT, which allows click, point, and drag operations on the Unix file structure. In addition to supporting Silicon Graphics' Graphics and Distributed Graphics Libraries, 4SIGHT supports the

X-Windows and NeWS windowing environments.

The system can also run MS-DOS programs, although somewhat slowly, by using Insignia Solutions' SoftPC emulator for MS-DOS, which is available as an option. Using SoftPC, you can connect a PC to the Personal IRIS via an RS-232C port and run MS-DOS applications from the PC or attach the optional floppy drive directly to the Personal IRIS.

The Personal IRIS is an indication of one direction the industry is heading in. "The Mac III or Mac IV will eventually use this kind of man-machine interface," said Silicon Graphics CEO Ed McCracken. "We have a 2- or 3-year window before Apple jumps into [the three-dimensional graphics] marketplace. We need enough applications by 1991 to withstand the competition."

TECHNOLOGY NEWS WANTED. *The news staff at BYTE is interested in hearing about new technological and scientific developments that might have an impact on microcomputers and the people who use them. If you know of advances or projects relevant to microcomputing, please contact the Microbytes staff at (603) 924-9281, send mail on BIX to Microbytes, or write to us at One Phoenix Mill Lane, Peterborough, NH 03458. An electronic version of Microbytes, which offers a wider variety of computer-related news on a daily basis, is available on BIX.*

Travel With A Fast Crowd.



Wherever your business takes you, take along the WorldPort 2400™ Portable Modem. Leaving the office doesn't have to mean leaving behind the world of high-speed, 2400 bps communications. Worldwide, in virtually every situation, including hotel rooms and phone booths, your ability to communicate clearly and efficiently remains intact.

Representing the cutting edge of modem technology, the WorldPort line of portable modems combine a broad range of features that bring you the best value in modems today. Features

that go far beyond costly internal units, such as Bell and CCITT standards, direct connect and acoustic interface (300 and 1200 bps), battery power, shirt pocket size, and a tiny price.

In fact, the WorldPort modems are the ultimate for both portable and desktop applications. And the WorldPort 2400 comes with Carbon Copy PLUS™ communications software, for even greater value.

If you want a modem that works where you do, put the WorldPort Series to work for you. In

the office. On the road. Or at home. For more information about our full line of WorldPort modems, or the name of your nearest dealer, call us at 800-541-0345. (In New York, 516-261-0423.)



Touchbase Systems, Inc.
160 Laurel Avenue
Northport, NY 11768
(516) 261-0423
TELEX: 6502848020
FAX: (516) 754-3491

WorldPort 2400 is a trademark of Touchbase Systems, Inc. Carbon Copy PLUS is a trademark of Meridian Technology, Inc.

MEET THE GUYS WHO CHEATED DIGITAL EQUIPMENT CORPORATION OUT OF \$60,000,000.



With their software, you can do everything a \$1000 DEC terminal does — on your PC — for a mere \$245.

The suave and debonair gentlemen bandits who sit before you virtually invented DEC terminal emulation for the IBM personal computer.

To the uninitiated, what that means is this.

With their software, you can do everything a \$1,000 DEC terminal can do — right on your own PC — for the paltry sum of only \$245.

Has business been good for our heroes?

You bet: to the tune of 60,000 users, who would otherwise have blithely gone out and bought DEC terminals.

Does this make DEC happy? What do you think.

Heavy DEC Experience + Heavy IBM Experience = Perfect Emulation.

The product these wizards invented is VTERM/220. And the reason it's so good, frankly, is that nobody has more experience than they do in DEC emulation on a PC.

With VTERM/220, you can emulate DEC's VT220, VT102, VT101, VT100, and VT52 terminals.

Of course, there's emulation and then there's EMULATION. This is *TRUE EMULATION*. Complete! Comprehensive! Thorough! Fast! Accurate!

Installation's a snap. Setup is a simple full-screen operation. You can toggle between DOS and the terminal screen and put mainframe data directly into PC spreadsheet and data base products such as Lotus 1-2-3™, dBase™, and Multiplan™. And for file transfer, there's XMODEM, ASCII, Kermit or VTRANS, our own high-speed, error-correcting protocol.

One last word from the Robin Hoods of software.

Are there other terminal emulators?

Of course there are.

But, we invented DEC terminal emulation at Coefficient. We know the subtleties, the little features (and the big ones) that make an emulator a joy to use. And we've incorporated them all into VTERM/220.

Just ask any of our 60,000 users.

They paid us the highest compliment of all.

They chose our software over the real thing.

A free working copy of their software. Free? Yes, free.

There's only one way to experience the speed, power, and simplicity of VTERM/220. Try it.

- Send me a free, time-limited, full-blown working copy of VTERM/220, which is mine to keep.
- Send me a free, time-limited full-blown working copy of your new VTERM/4105 or VTERM/4208 Tektronix graphics terminal emulators.

Name _____

Title _____

Company _____

Address _____

Telephone (____) _____

I am a user dealer.

Coefficient Systems Corporation

611 Broadway, New York, New York 10012

Voice: (212) 777-6707, ext. 422 Fax: (212) 228-3137

Telex: 6503156498 MCI Mailbox: CSC BYT 11/88

PC is a registered trademark of IBM. DEC and VT are registered trademarks of Digital Equipment Corp.

The Ultimate Business Machines

In just three years, CLUB American Technologies has grown into a multi-million dollar computer manufacturer. What's the secret to our success? The answer is simple, CLUB delivers solidly designed systems which are famous for high performance and superior quality. That's why so many fortune 500 companies depend on us. Additionally, CLUB's on-line engineers are available to support you every business day with optional on-site service available.

CLUB Model 200 Series

The Model 200 Series are OS/2 compatible, 80286 based systems. They are available in either 8 or 10 MHz versions to fit your specific needs. These economical, yet full featured AT compatibles are perfect for any applications such as spreadsheets and word processing.



Model 200 Series Features & Pricing

Intel 80286 CPU - 208/208S-6/8MHz, 210/210S-8/10MHz, 211-8/10MHz '0' wait state, 512K DRAM, 1.2MB Floppy Disk Drive, 80287 Math Coprocessor Socket, HD/FL Controller (controller is built-on motherboard for 'S' Models) Keyboard Speed Switchability ('S' Models), 2 Serial/1 Parallel Ports (211), 192 Watt Power Supply, 101 Key Enhanced Keyboard, Documentation and more.

200 Series with Monitor and Adapter			
Model with Hard Disk	Mono	EGA	VGA
208 or 208S with 20MB	\$1275	\$1625	\$1875
208 or 208S with 40MB	\$1420	\$1770	\$2020
210 or 210S with 20MB	\$1705	\$2065	\$2305
210 or 210S with 40MB	\$1850	\$2210	\$2450
211 with 20MB	\$1805	\$2165	\$2405
211 with 40MB	\$1950	\$2310	\$2550

CLUB Model 212 Series

With an effective throughput of 16 MHz, the Model 212 Series is as fast as many 386 machines at a fraction of the price. Compatibility with the existing AT standard ensures that the Model 212 will run your large databases, and complicated financial software today, as well as OS/2 applications tomorrow.



Model 212 Series Features & Pricing

Intel 80286-8/12, 1MB of DRAM, 1.2MB Floppy Disk Drive, 1:1 Interleave HD/FL Controller, 80287 Math Coprocessor Socket, Clock/Calendar/Configuration with Battery Backup, Reduced Chassis (212D), 192 Watt Power Supply, 101 Key Enhanced Keyboard, Complete Documentation, and more

212 Series with Monitor and Adapter			
Model with Hard Disk	Mono	EGA	VGA
212 with 40MB	\$2250	\$2615	\$2850
212 with 70MB	\$2505	\$2870	\$3105
212D with 40MB	\$2190	\$2550	\$2790
212D with 70MB	\$2445	\$2805	\$3045



CLUB Model 300 Series

The Model 300 Series 80386 microprocessor's state of the art design brings mainframe capability to the desktop at a vastly lower cost per seat. Complete compatibility with OS/2 and Unix give the Model 300 Series the ability to meet the most demanding multi-user and multi-tasking applications. Let CLUB give you the key to increased productivity in today's complex office and engineering environments.

Model 300 Series Features & Pricing

Intel 80386 CPU - 8/20 (320), 8/16 (316S), 1MB 32-bit DRAM (320), 1MB DRAM (316), 1.2 MB Disk Drive, 1:1 interleave HD/FL Controller (320), HD/FL Controller (316S), 80387 Math Coprocessor Socket (320), Weitek Support (320), 80287 Math Coprocessor Socket (316), 8 expansion slots, Clock/Calendar/ Configuration w/battery backup, 192 Watt Power Supply, 101 Key Keyboard, Documentation, and more.

300 Series

with Monitor and Adapter

Model with Hard Disk	Mono	EGA	VGA
316S with 40MB	\$2690	\$3050	\$3420
316S with 130MB	\$4060	\$4420	\$4790
320 with 70MB	\$4005	\$4330	\$4675
320 with 130MB	\$5120	\$5445	\$5790

CLUB Model 110

The Model 110 is an affordable entry level computer. It's perfect for general business applications and for low cost network nodes.



Model 110 Features & Pricing

Intel 8088 CPU-4.77/10 MHz, 256K RAM Maximum 640K, Floppy Disk Drive and Controller, 8 Expansion Slots, 150 Watt Power Supply, 101 Key Keyboard, Documentation and more

100 Series

with Monitor and Adapter

System & Hard Disk	Mono	EGA	VGA
110 with 20MB	\$895	\$1255	\$1495
110 with 40MB	\$1080	\$1440	\$1680

Peripherals

For your convenience, we offer the latest peripherals to enhance your systems. Our manufacturing facilities are geared to build systems the way you want them. Call and tell us what you need. Here's a list of just some of the products we carry.

Storage.

Floppy Drives: 5.25" - 1.2MB \$95
5.25" - 360K \$85
3.5" - 1.44MB \$120
3.5" - 720K \$105
Tape Backups: Internal: 40MB \$580
60MB \$650
125MB \$995
External: 40MB \$620
60MB \$690

Multifunction & Memory

(all prices with 0K)

384K memory card for XT \$99
576K memory card for XT \$42
2MB multifunction card for AT \$110
3MB extended memory card for AT \$110
10MB EMS card for AT \$150
2MB EMS card for AT \$110
Mini I/O for XT and AT \$75
Mini I/O w/ floppy controller for XT \$85
80286 accelerator card for XT \$299

Modems

1200/300 Baud rate internal \$99
2400/1200/300 Baud rate internal \$175
2400/1200/300 Baud rate external \$210
1200/300 Baud pocket Mini Modem \$139

* All modems come with Bitcom software

Printers

Star Micronix NX 1000 9 pin \$199
Star Micronix NB-24-10 24 pin \$493
Epson FX 1050 \$595
HP Laser Jet \$1815

Products for PS/2

RAM 4000 (EMS) card OK \$399
60MB Tape backup internal \$1095
60MB Tape backup external \$1285
120MB Tape backup external \$1595
PS/2 modem 2400 baud internal \$299

Others

80287-8 \$230
80287-10 \$279
80387 Call
Ram chips Call
Logitech Mechanical mouse \$79
Optical mouse \$75
DOS 3.3 \$95

To Order:

Continental USA, Hawaii, Alaska:

Call (415) 490-2201

In Canada Call PC Centre,

Call (416) 470-0560

International

Call (415) 683-6623

Customer Support &

Technical Hotline

Call (415) 683-6580

Corporate, University and
Government P.O.'s Welcome

All prices are subject to change and quantities may be limited. We reserve the right to substitute equivalent items.

OS/2, MS DOS, Unix, IBM PS/2, PC, XT, AT, Bitcom, Star Micronix NX-1000, NI-24-10, Epson FX-1050, HP Laser Jet, Logitech Mechanical Mouse, Intel, VGA, EGA are the trademarks or registered trademarks of their respective companies

CLUB V v.1 8/23/88

CLUB

American Technologies, Inc.

3401 W. Warren Ave. Fremont CA 94539

Save Money on Quality Software

\$1.99 Per Disk



Membership Special

For only \$19.95 (reg. \$34.95/year) become a MicroCom Systems member and receive:

- "The Shareware Book", a 300+ page guide to shareware for the IBM PC. Includes helpful information for the new PC user! \$12.95 if ordered separately.
- A one year subscription (6 issues) to "Shareware Review", each issue featuring a free new-release diskette from The MicroCom Collection.
- Reduced member prices!
- Any disks below for only \$1.99 each, (\$2.99 for 3.5") w/money back guarantee!

Hundreds of disks available. Free catalog with any order!

- BUSINESS 1—Easily create, fill in and print business forms.
- BUSINESS 2—Chart data on bar, pie graphs. Find trends! ★
- CAD 1a,b—(2 disks) Paint, draw, design w/Fingerpaint. ★
- CAD 2a,b—(2 disks) Draw 2D/3D designs. Hrd disk/640K. ★
- CAD 3—Generate your own custom flowcharts with PC-Flow.
- COMM 1a,b,c,d—(4 disks) Log onto bulletin board systems.
- DATABASE 1a,b—(2 disks) The File Express database mgr.
- EDUCATION 1—New PC users can painlessly learn DOS.
- EDUCATION 3—Build dazzling typing speed w/PC-Fasttype.
- EDUCATION 8—Improve your Spanish w/o dry, dull books!
- EDUCATION 9—Learn French skills w/o boring teachers!
- EDUCATION 10—Practice German with these easy drills.
- FINANCE 1a,b—(2 disks) A personal bookkeeping manager.
- FINANCES 3a,b—(2 disks) Prepare financial spreadsheets.
- GAMES 1—3-D Pacman, Kong, Spacwar, missiles, etc. ★
- GAMES 2—Qubert, Pango, Centipede, Hopper (Frogger). ★
- GAMES 3—Blackjack (you set rules), Armchair QB, Empire.
- GAMES 4—Star Trek, the orig Colossal Caves Advent, more.
- GAMES 5—Hack, you and your trusty dog in a wild adventur.
- GAMES 6—Pinball, Othello, Dragons, Sopwith (fly onel). ★
- GAMES 8—Blast enemies w/Striker, conquer world w/Fisk.★
- GAMES 11—High res Aldo's adventure, MahJongg. EGA.
- GAMES 12—Backgammon, Wordplay (like wheel of fortune).
- GAMES 13a,b,c,d,e—(5 disks) Make yr own advent games!
- GRAPHICS 1—Make color slide shows for demos/training! ★
- GRAPHICS 2a,b,c—(3 disks) Produce great 3D graphics. ★
- HUMOR 1—Amuse w/fun faces, unfriendly DOS & more!
- INFO 1a,b—(2 disks) 150+ grt cooking recipes. Add yr own!
- INFO 2a,b—(2 disks) Search for addresses w/Zip-Phone xref.
- INFO 3a,b,c,d—(4 disks) Access famous quotes from history.
- LANGUAGE 3a,b—(2 disks) A86 macro assembler/debuggr.
- MUSIC 1a,b—(2 disks) Play tunes or use editor/composer. ★
- MUSIC 2a,b—(2 disks) Record or play tunes w/Piano Man!
- ORGANIZER 1—DeskTeam (Sidekick clone) & Judy calnder.
- PRINTER 1—Packed w/utills for print spooling, banners, etc.
- SHELL 1—A simple, fast and easy DOS menu prog for PCs.
- SIMULATION 1—Fireworks, maze maker, roving eye, etc! ★
- SIMULATION 3—Birdsongs, aquarium w/fish, stars, more. ★
- SIMULATION 4—High res flowers, landscapes, fish. EGA.
- UTILITIES 1—A collection of invaluable genl DOS utilities.
- UTILITIES 2—More great DOS utills, incl burnout protection.
- UTILITIES 3a,b—(2 disks) Total debugger/diagnostic progs.
- UTILITIES 5—Hard disk utills to verify, format, park disk drives.
- UTILITIES 7—More adv utills; undelete files from hard disks.
- WORD 1a,b—(2 disks) Powerful PC-Write word processor.

★ Disks so marked above require a color graphics adapter.
All disks \$1.99 each (\$2.99 for 3.5") w/o membership add \$1.50/disk.
Membership w/3.5" disk in each magazine (instead of 5.25") is \$25.95.

MicroCom Systems Cost of disks
3673 Enochs Street Membership
Santa Clara, CA Shipping \$3.00
95051 CA res tax
Total encl.

Phone today for 24-hour shipment!

VISA (408) 737-9000 MasterCard
©1988, MCS Mon-Fri 7am-9pm, Sat-Sun 8am-5pm BY-11/88

LETTERS

Does Data Need Liberating?

The letter from Evan Provisor ("Data Liberation," August) proposed a Freedom of Information Act relating to the data structures used in proprietary software. As a consultant, I can sympathize with his dudgeon, but as a systems developer, I'd like to make a few tempering points and offer a different suggestion to purchasers of packages than that they require information about a package's data structures.

Some data structures of packages are available—there are two volumes of Jeff Walden's formats books, for example. (*File Formats*, published by John Wiley & Sons, New York, 1986, is the first.) These open up Lotus 1-2-3, MultiMate, dBASE, Multiplan, SuperCalc, and Symphony, among others. Of course, these were released for a good commercial reason: to enable the creation of add-ons that leverage sales of the original product.

But the distinction between data and program code is not as rigid as Provisor seems to think. I can imagine applications where the data structures in effect embody 75 percent of the algorithmic intelligence in a program.

This is particularly likely in the areas of sophisticated data storage software and in applications that gain speed by precrunching input (like satellite images) into an intermediate form for quicker end processing. When the program as a whole gains significantly through the ingenuity and originality of its data structures, these are respectably regarded as proprietary.

Such inventiveness is unlikely to have been used in a medical office accounting package, so I can understand Provisor's irritation. There is a better criterion for package selection, however, than availability of internal file formats. After all, cross-loading based on internal file formats requires a programmer, which should not be necessary even if consultation is.

I always check that a package can export and import its data in a standard format, such as quoted BASIC or DIF. This

way, the data per se is always available, and importing it into a new package is a simple matter of shoving the ASCII data around, rather than programming export pipes right into the old package's data files.

Lindsay Gillies
New York, NY

The Last Word on BYTE

I've been a regular reader of BYTE for the past 5 years. I've watched it change over the last 18 months, and I'm happy to say that it has emerged as the viable source for reliable, up-to-date information about what's happening in the computer industry today.

Not only does the magazine cover a broad base of computer types and manufacturers, but the evaluations and reports are more accurate and technically sound, emanating as they do from people with a history of involvement, insight, knowledge, and training in computer sciences.

BYTE is still the last word in understanding the real truth of keyboard technology. Keep up the good work!

Wendell Anderson
Hamilton, Bermuda

Hartley vs. Fourier

We enjoyed the enthusiastic article entitled "Faster Than Fast Fourier" by Mark O'Neill (April). From the August Letters, it seems that the article has stimulated some lively correspondence.

First, regarding John C. Polasek's letter, the hazard he refers to is explained in R. N. Bracewell's *The Hartley Transform*.

continued

WE WANT TO HEAR FROM YOU. Please double-space your letter on one side of a page and include your name and address. We can print listings and tables along with a letter if they are short and legible. Address correspondence to Letters Editor, BYTE, One Phoenix Mill Lane, Peterborough, NH 03458.

Because of space limitations, we reserve the right to edit letters. Generally, it takes four months from the time we receive a letter until we publish it.

Who Says FoxBASE+ is Better than dBASE®?

COMDEX
Booth H4



The Experts!

The Best Just Got Better—Now Shipping New FoxBASE+ Version 2.10!

Nicholas Petreley, *InfoWorld* Review Board:
"FoxBASE+ has outdone itself. Once again, FoxBASE+ earns an "excellent" in performance, with kudos for responding to user suggestions. For sheer productivity, there is no other choice." *InfoWorld* "Editor's Choice" for 1987 and 1988!

P.L. Olympia, Founder & President, National Dbase Users Group / *Government Computer News*:
"FoxBASE+ is a supercharged dBASE, with all the features Ashton-Tate forgot. If you're into serious dBASE development and have not tried FoxBASE+, you are living in the dark ages and wasting your company's money."

George F. Goley IV, Cont. Editor, *Data Based Advisor*:
"The product is fast, very compatible, fast, easy to use, fast, relatively inexpensive, and very fast. In every test, FoxBASE+ outperformed the other products. And people who answer the phone at Fox know what they are talking about."

David Irwin, Former President/CEO, *Data Based Advisor*:
"From the dBASE compatibility standpoint, FoxBASE+ is flawless. From the speed standpoint, FoxBASE+ is unbelievable. From the "lazy factor" standpoint, FoxBASE+ is perfect."

Glenn Hart, Contributing Editor, *PC Magazine*:
"Initial tests of FoxBASE+ were simply stunning. In many ways, FoxBASE+ gives you the best of both worlds: all the benefits of interactive development and debugging, plus the speed and code protection of a compiler."

Adam Green, Contributing Editor, *Data Based Advisor*, dBASE Author:
"For the PC, FoxBASE+ has consistently set the performance standard for dBASE compatible languages. For the Macintosh, FoxBASE+/Mac will set standards for innovation and leadership in a new dBASE implementation."

Don Crabb, Contributing Editor, *InfoWorld*:
"You can expect blazing speed on the Mac. FoxBASE+/Mac breezes past tests that have proven stumbling blocks for Macintosh databases in the past. FoxBASE+/Mac combines complete dBASE compatibility with a genuine Macintosh user interface."

This is what they said about Version 2.00 of FoxBASE+ . Imagine what The Experts will say about New Version 2.10 with these added features: Menu-Driven Interface, Program Documentor, Screen Painter and Template-Based Application Generator . . . and Version 2.10 is even faster than 2.00!

Join The Experts. Get your copy of the New FoxBASE+ Version 2.10 today! Now available at your nearest, quality software retailer, or directly from us by calling (419) 874-0162 Ext. 320.

Because, when it comes to speed, compatibility and value, nothing runs like the New FOX—Version 2.10!

Fox Software
Nothing Runs Like a Fox.

Fox Software	(419) 874-0162 Ext. 320.
118 W. South Boundary	FAX: (419) 874-8678
Perrysburg, OH 43551	TELEX: 6503040827 FOX

Circle 134 on Reader Service Card
FoxBASE and FoxBASE+ are trademarks of Fox Software.
dBASE and dBASE III PLUS are trademarks of Ashton-Tate.
Macintosh is a trademark of Apple Computers, Inc.



The original AnthroCart. Mobile.
Incredibly strong. So many ways to solve
your space and equipment problems.
Choose different sizes. Move
shelves around. Add space saving
options.

AnthroCart. Well designed
Technology Furniture.

Look for our name.

AnthroCart®

Call us for a free catalog: 800-325-3841



Made in U.S.A.
All steel frame construction
Easily holds up to 150 lbs.



ANTHRO

AnthroCart and Technology Furniture are
registered trademarks of Anthro.

**Anthro®
Technology Furniture®**

3221 N.W. Yeon St.
Portland, OR 97210
503-241-7113
Telex: 940103

form (Oxford University Press, New York, 1986) in a way that would satisfy him. The answer is that the kernel $\cos(2\pi/T) + \sin(2\pi/T)$ preserves all the original information, just as the complex Fourier kernel does, because the first term works on the even part of the data and the second part works on the odd part. That's why the plain sine function would not serve just as well.

B. D. Ripley's letter cites a letter by Gary Bold in which the fast Hartley transform (FHT) is compared with "sophisticated FFT algorithms," also referred to as "existing FFT methods," which are found to give "the same speed-up factor." In other words, Bold accepts the factor-of-2 speedup relative to the complex FFT, and he certainly does not support Ripley's notion that Bold's FFT is "considerably faster." In fact, Bold is comparing two things that, he says, have the same speedup factor.

What is being compared? Ripley gives a list of times, but he doesn't say what algorithm he used or who wrote them. He may have written the Hartley version for the numerous computers he mentions himself, which requires particular caution when one has an ax to grind.

However, Bold does say what he did. We recognize the "sophisticated FFT algorithm" as the well-known unilateral Fourier transforms. They are indeed exactly as fast as the Hartley, but they cannot retransform their own output. In other words, they should not be called Fourier transforms at all, because the Fourier transform is a reciprocal transform. The trouble is easily understood. A unilateral Fourier transform of Type I, or a right-handed Fourier, takes real input and gives out the correct complex result. After you operate on that complex Fourier transform, for example, by applying a little low-pass filtering, and wish to return to the original function domain, you cannot use that program anymore. It takes only real inputs. You must supplement it with a left-handed unilateral transform algorithm. You wind up with a combination of two unilateral Fourier's plus a management program constituting a software package. The totality is equaled by just one Hartley program. Whenever you call the Hartley, you go straight to the other domain, regardless of whether you are in the time or in the frequency domain at the moment.

The sophisticated Fourier packages, of which there are several versions, regain the factor of 2 gained by the Hartley—but at the expense of a factor of 2 in

continued

**RECEIVE A
FREE
SIVA 386
SYSTEM
(\$2995 VALUE)**

for the Holidays*

with the purchase of Quality
Hardware/Software Products.

See VNS America Corp. advertisements**
in this issue or call

1-800-252-4212

VNS America Corp.

Suite 270, 910 Boston Post Road
Marlboro, Massachusetts 01752 U.S.A.
In Massachusetts 508-460-0016
FAX: 508-481-2218

*Offer good until December 31, 1988.

**See Advertisers Index for pages.

See the Everex Step computers at Comdex
Las Vegas Hilton Center
Booth #H8206-H8406

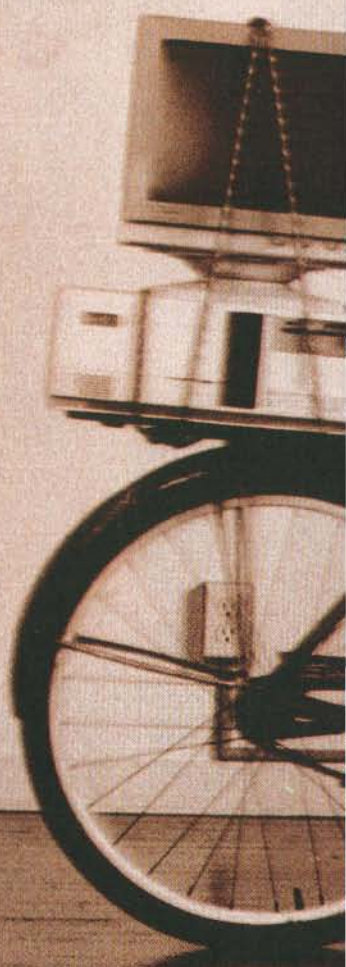
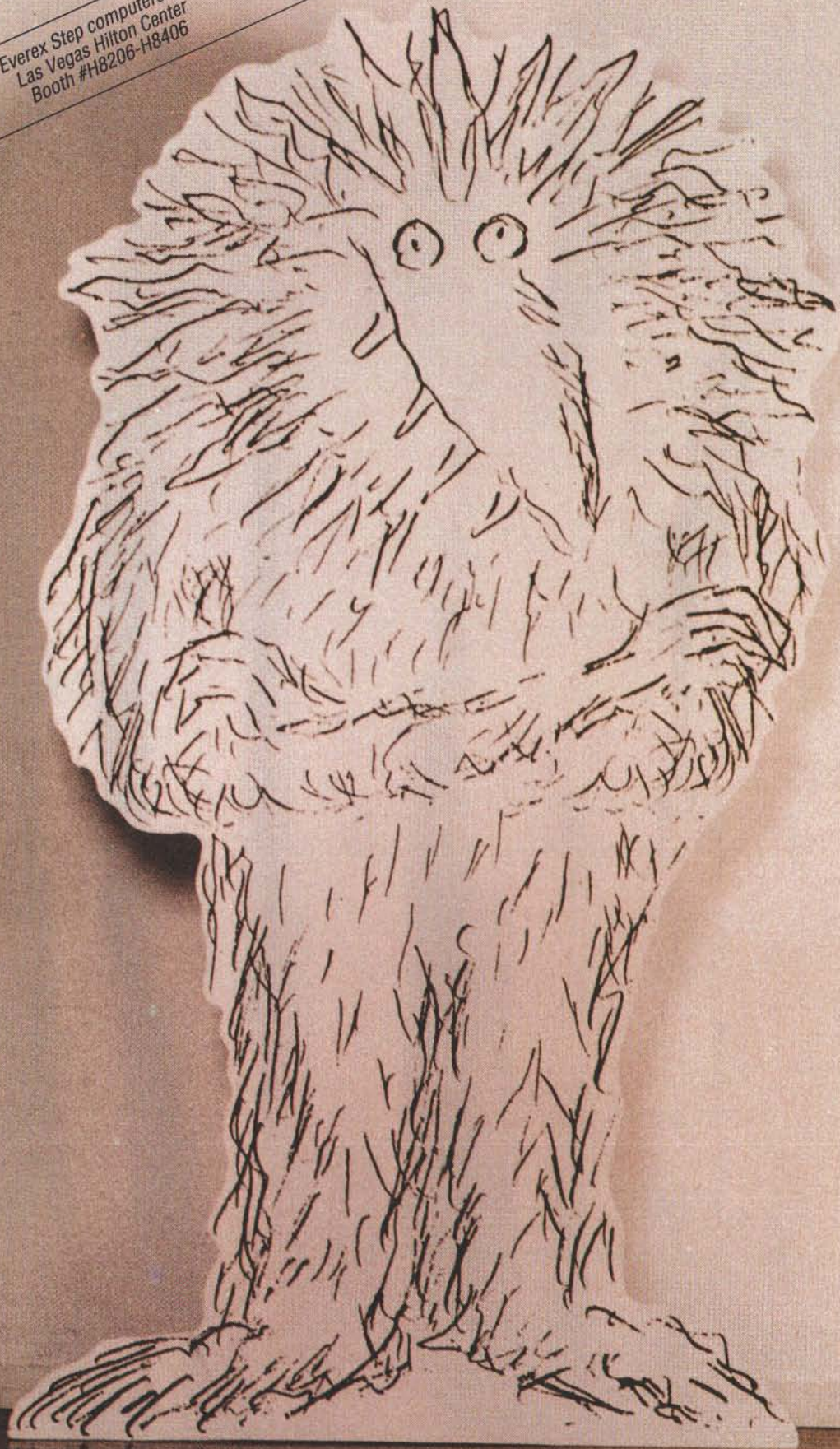

Everex and Step are trademarks of Apex Systems, Inc. 386 is a trademark of Intel Corp.

EVEREX

Step 286/12	2.45 MIPS
Step 286/16	3.27 MIPS
Step 386/16	3.93 MIPS
Step 286/20	4.24 MIPS
Step 386/20	4.91 MIPS
Step 386/25	6.13 MIPS

Source: Power Meter MIPS Version 1.3. The Database Group, Inc.

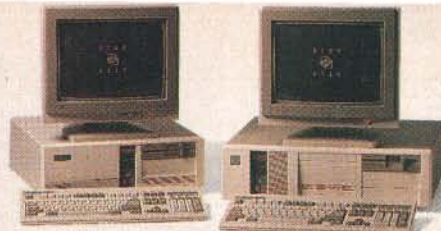

"I used to be afraid of monsters. Now I can't get along without them."

Janet Johnson, President
Coordinated Digital Systems
Dayton, Ohio



"I'll be right over."

The most incredible collection of people find their way to my door. Students. Aerospace engineers. Genealogists.

They come because they hear we do more than sell computers out of a box. We try to make everything very personal.

We know our products backwards and forwards because we use them ourselves. We write custom software.

We're writing a lot of business.

We work almost exclusively with one computer company. Everex.

Because every one of their six computers is at the head of its class.

And because they take care of me the way I like to take care of my customers.

Find out more about Everex Step computers. Call 1-800-356-4283. Everex Computer Systems Division, 48431 Milmont Drive, Fremont, CA 94538.

Circle 124 on Reader Service Card (DEALERS: 125)



quantity of code and memory storage and a small management penalty.

R. N. Bracewell
John Villasenor
Dept. of Electrical Engineering
Stanford University
Stanford, CA

"Executivitis" Blues

How long has VGA been out now? A year at least, wouldn't you say? Yet, as nearly as I can determine, there is not a single

programming language available to IBM clone users that supports even the lowest-resolution of the true VGA modes—not to mention the 1024-pixel by 768-pixel high-resolution mode for which Orchid, Genoa, and a number of other manufacturers now provide off-the-shelf adapter hardware (albeit for 16 colors, not 256) and for which at least a half-dozen outfits offer suitable color monitors.

Let's carry this one step further: As nearly as I can determine, not one of the

major U.S. commercial software houses has yet so much as faced the perilous executive decision to attack the crushing technical problem of providing to the user a valid option of maximum-resolution, maximum-color video output from their products, to keep pace with available hardware capabilities. (I leave aside a few special-purpose programs, such as CAD and spreadsheets. And I remark that though Microsoft has an older version of Windows that supports 1024-pixel by 768-pixel resolution, its latest 80386 version apparently does not.)

Do their programs have to stop selling entirely before the executive brains in question bestir themselves to begin considering the matter? I hope I have this all wrong.

Am I doing an entire "industry" an injustice? Or are we seeing here in microcosm the same "executivitis" that sank Detroit?

Thomas E. Phipps Jr.
Urbana, IL

IBM and Licensing

Bruce F. Webster ("Macintosh Redux," August) refers to "[IBM's] subtle hints about landing with both feet on anyone cloning PS/2s without a license." But that is precisely the point. IBM is prepared to sell licenses, and at reasonable prices, too. It should be possible to pay the license fee and still undersell IBM on all but the largest orders. IBM is not using its patents, which in any case are much less dubious than visual copyright, to secure a legal monopoly on a large sector of the business of putting chips in boards and the boards in boxes and marketing the boxes. There is a difference between collecting royalties and using intellectual property rights to restrain trade, as a number of the young Turks of the personal computer industry have done.

Note that this applies to separately sold software, as well. A large part of the expense of a typical program is for marketing. Cloning generally means that the original vendor has to face facts about its marketing operation.

Andrew D. Todd
Springfield, OR

YAPL: Yech!

I had gone through the article entitled "A Better C?" by Bjarne Stroustrup (August) and was reading "HyperCard: How Does It Work?" by Laurence H. Loeb (August *Macintosh Special Edition*) when a feeling of impending doom settled upon me—sensory overload from

continued

C_talk™ The Practical Union of C and Smalltalk

Add a new dimension to your C compiler.

From C:

- Ease of application delivery – portability
- Performance – speed and efficiency of C
- Familiarity of C – use all your existing C code

From Smalltalk:

- Data abstraction – data hiding/encapsulation
- Full object inheritance
- Polymorphism – message sending with dynamic binding

Boost Your Productivity! C_talk's practical approach to object-oriented programming in C allows you to realize substantial productivity gains using these tools:

- C_talk's Browser – a powerful Smalltalk-like browser for building software objects
- An automatic Make utility – for building applications
- A Preprocessor – for converting objects into C source code.
- A set of Foundation Classes – to use as basic building blocks.

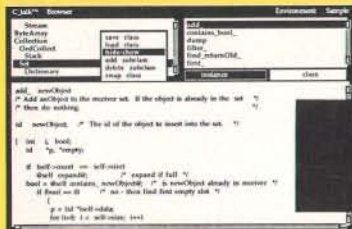

\$149⁹⁵

Why C_talk?

C_talk has been proven successful in delivering several large-scale systems in demanding realtime environments. It's concise, easy to learn and use. It is programming in C (not a new language), while adhering to the Smalltalk paradigm.

C_talk is the practical, and affordable, union.

C_talk is designed to operate with MSDOS on IBM or compatible computers. At least 512K of memory, a hard disk and mouse are recommended.

Order today!

Call or write:
CNS, Inc.
Software Products Dept.
7090 Shady Oak Rd.
Eden Prairie, MN 55344
Tel: (612) 944-0170
Fax: (612) 944-0923

Add for shipping \$5 US, \$25 Int'l.
(30-day money-back guarantee)



...providing and advancing
object-oriented methodology.

C_talk is a trademark of CNS

CNS is a registered trademark of CNS, Inc.



Natural selection provides unique passive protection for the porcupine.

The Block -- Natural Selection For Software Protection



Inventor and entrepreneur Dick Erett explains how "The Activator" provides sane protection for your intellectual property.

"In any industry, just as in nature, the process of natural selection raises one solution above another. Natural selection is the most elegant of engineers.

In the area of software protection The Block has been selected by the marketplace as the solution that works. Over 500,000 packages are protected by our device.

For the past 4 years our philosophy has been; 'You have the right and obligation to protect your intellectual property.'

A New Ethic For Software Protection

In allowing end-users unlimited copies of a software package and uninhibited hard disk and LAN operation, The Block has created a new ethic for software protection.



By removing protection from the magnetic media we remove the constraints that have plagued legitimate users.

They simply attach our key to the parallel port and forget it. It is totally transparent, but the software will not run without it.

A New Technology For Software Protection

Our newest model, The Activator, builds on our current patented design, and establishes an unprecedented class of software protection.

We have migrated and enhanced the circuitry of The Block to an ASIC (Application-Specific Integrated Circuit) imbedded in The Activator.

This greatly improves speed and performance, while reducing overall size. Data protection can also be provided.

Programmable Option

The Activator allows the software developer the option to program serial numbers, versions, or other pertinent data known only to the developer, into the circuit, and access it from the program.

Once you program your part of the chip, even we have no way to access your information.

The ASIC makes emulation of the device

virtually impossible. It also presents an astronomical number of access combinations.

Full 100% Disclosure

Since The Activator is protected by our patent we fully disclose how it works. Once you understand it, endless methods of protection become evident.

Just as no two snowflakes are the same, no two implementations of The Activator are identical. And like the snowflake the simplicity of The Activator is its greatest beauty.

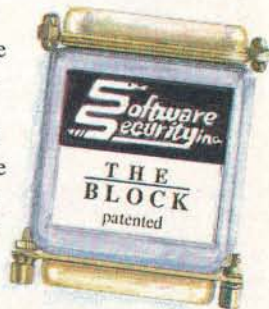

We never cramp your programming style or ingenuity. Make it as simple or complicated as you desire.

Let us help safeguard what's rightfully yours. Please call today for additional information or a demo unit. *It's only natural to protect your software.*"

1-800-333-0407

In Connecticut 203-329-8870

Fax 203-329-7428

Software Security Inc.

870 High Ridge Road
Stamford, CT 06905

Unlimited Copies • Programmable • Small Size • Fast • Patented • Data Protection

YAPL (yet another programming language).

In the 30 years after the Mark I computer switched on in 1945, I estimate that some three dozen programming languages kept computers humming. When dBASE II introduced the microcomputer user to a programming language, it also created an entire industry to teach the hapless user the art of programming in dBASE II. Unfortunately, the power of this technique wasn't lost on other pro-

gram developers. So, in the past 3 years especially, nearly every major application has a programming language. Oh, you don't have to call it a programming language, you can call it a script, a stack, or a complex macro. All different. Even having applications developed by one company doesn't lead to uniformity. Look at Borland's Sprint, Paragon, Reflex, and Quattro. All have languages; all are different.

At one time, you could get familiar

with a language or two and do wonderful things. Now simply picking up the normal complement of applications will make you a victim of YAPL.

Walter J. Rottenkolber
Visalia, CA

Seek and Ye Shall Find

I am trying to find a supplier or the author of a program called FABS/86M (Fast Access B-tree Structure). It is an assembly language program to enable high-level languages, BASIC (interpreter and compiler), Pascal, FORTRAN, and COBOL to retrieve data using B-trees.

The only information I have is from the copyright notice, which reads as follows:

FABS86M Version 1.06 12-13-82 (13 Dec 82) Computer Control Systems Inc.

This program has many advantages, such as duplicate keys, multiple keys, ASCII or integer keys, fast access, and ease of use. Its main disadvantage is that it does not support path names or more than six open files at a time.

I'd appreciate any information you can provide.

Ian Sidebottom
South Humberside, UK

According to Data Sources, you can contact Computer Control Systems, Inc. at Route 3, P.O. Box 168, Lake City, FL 32055, (904) 752-0912.

Ackerman Exercise

I noted with interest the letters regarding recursion (August).

Your readers may be interested in the "Ackerman function," to which I was introduced in 1970 by Dr. R. S. Northcote, director of the ICL Software Development Centre in Adelaide, South Australia.

I regularly challenge my students to deliver to me the value of Ackerman(5,5).

```
Ack(m,n) = if m = 0
            then n + 1
            else
            if n = 0
            then Ack(m - 1, 1)
            else
            Ack(m - 1, Ack(m, n - 1))
            endif
            endif
```

Test this by finding that 1 is Ack(0,0); 3 is Ack(1,1); and 9 is Ack(2,3).

Christopher Greaves
Islington, Ontario, Canada ■

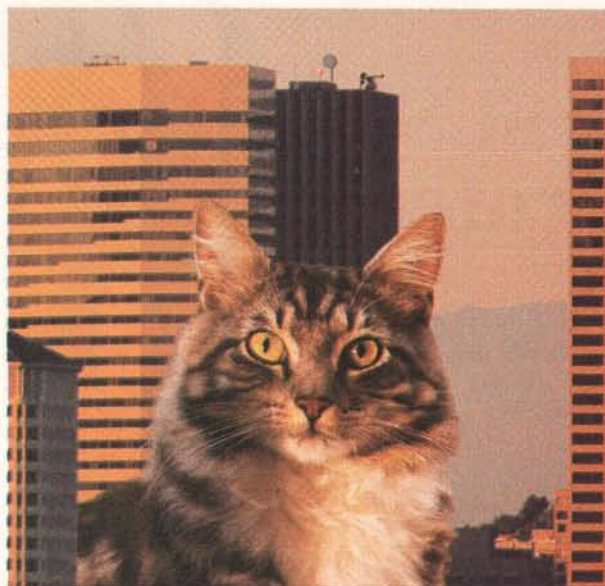

PC-Write 3.0 — Working on a whole new scale.



Power. Speed. Performance.

We listened to you and added hundreds of features to PC-Write.

Larger Files — Break the 60K file limit! Use all available DOS memory to edit large documents. Rapidly search and switch between related files. Lock files on a network.

More Formats — Edit multiple columns on-screen. Or mark text as a box, then position and format it. Create tables and scripts faster.

Easier To Use — Stay on track with on-screen "reminder" lines. Select page layout and fonts with new menus. Fix typing mistakes with our improved spelling checker.

New catalog adds value.

We offer popular products that work well with PC-Write.

New Capabilities — Choose products such as InSet™ graphics, WordFinder™ thesaurus, or popular soft font, grammar checker, foreign language, and scientific packages.

Special Discounts — Registered PC-Write users get phone support and reduced prices for all products.

Still only \$89.

The \$89 registration fee gives you software, user's guide with tutorial, phone support, two free updates, and our newsletter. PC-Write 3.0 is still shareware, so you can give copies to others to try, free!

Order PC-Write 3.0 today.

Call 1-800-888-8088 BYTY

90-day money-back guarantee

PC-Write is not shareware outside the U.S. and Canada. PC-Write™ Quicksoft. WordFinder™ Microlytics. InSet™ InSet Systems. Quicksoft, Inc., 219 First Ave N #224-BYTY, Seattle, WA 98109. 206-282-0452.



Quicksoft

Just a few
months ago,
computers this powerful
were tracking
planetary movements,
pondering
quantum physics
and building
rockets.



Now they're taking



care of business, too.

Introducing the COMPAQ DESKPRO 386/20e. 20-MHz 386 performance designed to fit the increasingly sophisticated needs of 286 users.

People who work with 386 personal computers used to be called rocket scientists. Now they're also called accountants, engineers, managers and CEO's. Thanks to the new COMPAQ DESKPRO 386/20e.

It delivers 386 power to people whose demanding needs have outgrown the capabilities of their 286 PC's. Better

yet, it packs all this power into a design that fits neatly on your credenza.

Start with speed. Everything in the new COMPAQ

DESKPRO 386/20e is optimized to go faster.

Its 20-MHz Intel 386™ microprocessor with cache memory is surrounded by the exclusive COMPAQ Flexible Advanced Systems (Flex) Architecture. This high-speed combination runs the world's largest library of software 25% faster than non-cache 20-MHz 386-based PC's. And 50% faster than non-cache 16-MHz 386-based PC's.

Its optimized 32-bit design also enables you to take full advantage of powerful 386 software and

multitasking operating systems such as Microsoft® Windows/386, MS® OS/2, XENIX® and UNIX.

You'll find that a long list of high-performance features is built in. One megabyte of memory. Sharp, high-speed VGA graphics. Support for 5¼" and 3½" diskette drives. And standard interfaces to connect a printer, mouse and communications devices.

Of course you have growth potential. Five expansion slots are available: four for a network card, mainframe communications board, modem or other devices, and one high-speed 32-bit slot that allows you to expand memory up to 16 megabytes.

You have options, too. There's room to add two high-speed fixed disk drives, with 110 or 40 megabytes of storage. You can choose a 135- or 40-megabyte tape backup. Or match the number-crunching power of a dedicated engineering workstation by adding a powerful Intel 387™ or Weitek 3167 coprocessor.

With its integrated design and performance, the COMPAQ DESKPRO 386/20e represents the ultimate space vehicle.

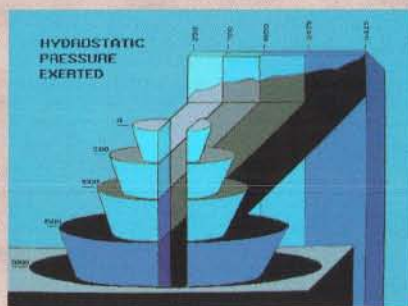

High-speed VGA graphics are built in.



You're in business with a 20-MHz 386 microprocessor.



Choose 5¼" and 3½" diskette drives.



Standard interfaces are on board.

COMPAQ

It simply works better.

Compaq makes high performance everybody's business.



Whether you use a personal computer for launching rockets or corporate acquisitions, Compaq delivers the highest-performing solution.

For those who want everything, now, the COMPAQ DESKPRO 386/25 is the most powerful PC available. For growing performance requirements, the new COMPAQ DESKPRO 386/20e is a move into the power structure. And for users considering 286 PC's, the COMPAQ DESKPRO 386s is an affordable route to the fast track.

These PC's are simply the highest-performing in the world. That's one reason PC experts rate COMPAQ highest overall. And why for the past four years COMPAQ has been added by more FORTUNE 1000 corporations than any other brand.

To make this performance part of your business, call 1-800-231-0900, Operator 70. In Canada, 1-800-263-5868, Operator 70. We'll give you the location of your nearest Authorized COMPAQ Computer Dealer and a free brochure.

COMPAQ® is a trademark of Compaq Computer Corporation. Intel®, Intel 386 and Intel 387 are trademarks of Intel Corporation. Microsoft®, MS® and XENIX® are trademarks of Microsoft Corporation. MS® Windows/386 and MS® OS/2 are products of Microsoft Corporation. Product names mentioned herein may be trademarks and/or registered trademarks of their respective companies.
*Registered U.S. Patent and Trademark Office. COMPAQ DESKPRO 386/25 graphics ©1988 Accent Software, Inc. ©1988 Compaq Computer Corporation. All rights reserved.

COMPAQ

It simply works better.

CHAOS MANOR MAIL

*Jerry Pournelle answers questions about his column
and related computer topics*

An "MIS Type" Speaks

Dear Jerry,

Alas, I and my profession have been defamed in that most hallowed of documents, BYTE, and by—all folks—Jerry Pournelle!

In your June column, you twice took misguided swipes at "MIS types" as if we were some variant of power-hungry czars. By using the collective phrase, you have lumped the evil and the saintly together into one unrecognizable mass. I know that I don't fit this unwholesome description.

A number of factors are retarding the use of personal computers in the office environment. Few, if any, result from self-centered management. By far the biggest problems arise from the current state of technology (or lack thereof) and the user community itself.

Take the user (please). My experience leads me to classify users into three distinct categories: the CRT-Shy, or folks who simply won't go near a computer; the Grumblers, those who will eventually learn and use a computer only after receiving threats of physical violence; and the Office of One.

The last category includes users like you—people who have seen the potential of small systems and take the time to investigate their power. Such users are in effect becoming one-person offices, producing their own numerical analysis, graphics, and prose. Only the most malignant of managerial attitudes could keep these people from using small systems.

The other problem is technology and the historical path information has taken. When a megabyte of memory carried the same price as a new automobile, centralized systems made the greatest sense. So, for decades, information was entered into, processed by, and dumped from large centralized computers. And there lies the rub. All that current, relevant, and sometimes critical information is still there, in the centralized computer—not the micros!

The technology for making all that centralized data available to all those de-

centralized computers is just now developing. Local-area networks (LANs) offer a path, as do trusty serial connections, but developing a solution that pleases everyone is still a dream. Limits on data throughput, not to mention the software problems inherent in meshing microcomputer programs with a central DBMS, are nontrivial.

There lies my point. "MIS types" are still confronted with the same problem as always, just in a different form: How do we get all pertinent data to all users across existing platforms, without investing every dollar of corporate profit? The answer is, we don't. We have to wait on third-party developers and primary vendors to create the tools we need before we can give them to the user.

There is hope. The IBM PC standard went far in taking the risk out of such development. DEC and Apple have formed an alliance that is causing quite a ruckus. ANSI and OSI are clearing the way for cohesive LANs. And MIS directors are watching all of the above, carefully.

Guy Smith
Titusville, FL

P.S. BYTE is a tough market for a freelance writer like myself to break into. Do you have any advice?

I can hardly disagree with that! My quarrel, probably overstated, is with people who want centralization for its own sake and who keep insisting that only centralization can get the job done.

Your classifications aren't bad, although I don't think they are either mutually exclusive or collectively exhaustive.

P.S. I fear that BYTE, like any other magazine, requires that you have something interesting to say, that it's well said,

continued

Jerry Pournelle holds a doctorate in psychology and is a science fiction writer who also earns a comfortable living writing about computers present and future. He can be reached c/o BYTE, One Phoenix Mill Lane, Peterborough, NH 03458, or on BIX as "jerrypp."

Circle 46 on Reader Service Card
**Four ways to build
better C programs...**

NEW! POWER SCREEN \$129

Screen I/O manager.

Features: ♦ screen painter ♦ virtual screens
♦ data validation ♦ context sensitive help
♦ unlimited screens ♦ definable keys
♦ & much more!

C TOOLS PLUS \$129

Full featured function library.

♦ For Microsoft C 5.0 and QuickC.

Features: ♦ TSR support ♦ direct video access
♦ VGA and EGA support ♦ windows and
menus ♦ DOS memory allocation ♦ interrupt
service routines ♦ & much more!

C ASYNCH MANAGER \$175

Asynchronous communication manager.

Features: ♦ speeds to 19.2K baud
♦ XON/XOFF protocol ♦ hardware
handshaking ♦ XModem file transfer ♦ I/O
buffers up to 64K ♦ & much more!

TURBO C TOOLS \$129

Full featured function library.

For Borland's Turbo C.

Features: ♦ TSR support ♦ direct video
access ♦ VGA and EGA support ♦ windows
and menus ♦ DOS memory allocation
♦ interrupt service routines ♦ & much more!

We're Blaise Computing, manufacturers of high quality function libraries designed to reduce the time and technical expertise required for serious applications development.

All of our packages include a comprehensive user reference manual with extensive examples, and sample programs.

Satisfaction guaranteed or return within 30 days for a full refund.

We have a full line of products for C and Pascal. For a free brochure or to order call

800-333-8087!

BLAISE COMPUTING INC.

2560 Ninth Street, Suite 316 Berkeley, CA 94710 (415) 540-5441

NOVEMBER 1988 • B Y T E 33

and that you have the luck to get it in front of the editor when he is looking for it.

As to how I got into BYTE, I did just the above, but long ago, when they needed more from outsiders.

I wish you well, but I don't hold out a lot of encouragement.—Jerry

Editor's note: Jerry's right, in that we receive a daunting number of freelance submissions each month. But you'll never know until you try: If you'd like to write for BYTE, drop a note to Editor, One Phoenix Mill Lane, Peterborough, NH 03458. Tell me what you propose to write, why it's right for BYTE, and why you're the best author for the topic. Include a writing sample, if you have one. And if you include a stamped, self-addressed envelope, I'll ship you a copy of our Writer's Guidelines.—F.S.L.

Translating CBASIC Source Files

Dear Jerry,

Like you, I started to use CBASIC many years ago, when it was the best thing around by far for writing useful and flexible programs in BASIC, and when it had yet to be abandoned by Digital Research. I, too, have a number of useful programs that were written in this language and that are now orphans.

What we both need is a way to translate the CBASIC source files into source for QuickBASIC, so that they can be recompiled and maintained using this language. This shouldn't be too hard to do in BASIC, or even in the VEDIT macro programming language, but it would certainly take time to do and to debug.

Do you know whether anybody has done this already, and where I might find such a translation utility?

Peter R. Maggs
Cambridge, MA

I just dug out the sources of all my accounting programs—all in CBASIC. While I had no trouble getting them to compile and link on the Cheetah 386—where they run awfully fast—I did miss a lot of the features of QuickBASIC 4.0.

Minnow Bear used to do a lot of add-on functions for CBASIC, but now that Digital Research has thoroughly abandoned the language, I don't hear from them any more. Pity: They did good work.

One thing CBASIC had that I wish they'd add to QB4 is the toggle that finds all undeclared variables. The XREF feature of CBASIC was nice, too. All in all, CBASIC had the potential to be a better language than either TURBO or QB4. What a pity it was abandoned!

Alas, I don't know of a good program

that would translate CBASIC into QB4. It wouldn't be that hard to write, of course. Maybe one of the readers knows of one.

—Jerry

Word Processor Roundup

Dear Jerry,

I have come to many of the same conclusions as you about word processors.

I gave up MultiMate long ago because it devoured chunks of text on certain kinds of document scrolling. That has probably been corrected, but I don't like it well enough to find out.

Of the command-driven programs, PC-Write is far and away my favorite. Although it is a "text-in-memory" system, it has a neat command for chopping up longer texts so they can be processed. I like to have an unlimited length option if it does not reduce speed. I'll probably be tempted back to PC-Write this spring if its promised new unlimited text-length version manages to maintain speed of operation. However, PC-Write is counter-intuitive, and a little absence from it requires a good deal of refresher time.

Textra is a simple, quick, transparent, and intuitive menu text-in-memory system. For me, this makes it too awkward for long documents. Moreover, it lacks the more complex operations. However, it's neat for correspondence.

WordPerfect, to which I constantly return, is, as you say, simply too cumbersome. It takes seven operations to cut and paste a fragment of text that Textra does in three. The segmented manual is frustrating. WordPerfect was salvaged for me by Karen Acerson's *WordPerfect: The Complete Reference*. But I cannot remember to always do the requisite exiting in every file manipulation. You have to do that to keep it from autocloning text copies within a file. I find this annoying. I also don't like the bugs.

Somewhat worse is the tedium of saving a text to ASCII. Some of WordPerfect's ASCII texts seem to lose columns if the column size of the target system is shorter. On many other word processors, this is quick, effortless, and readily transitive.

I haven't tried Microsoft Word yet because of its reputation for being slow. I understand this has been corrected, and, if so, I suppose I shall have to try it. I hear that it refuses to read from any other word processor, not even in ASCII. I'll look forward to your next report on it.

But this highlights another problem. I am now semifluent in five word processors. Even though one can quickly start using the basic functions of any new word processor, real satisfaction involves

a learning period of several hours. This, along with its reputation for slowness, has kept me from trying Nota Bene.

On top of this, the hypertext knowledge processors are beginning to appear. I'll probably have to try out three or four of them before settling down with one, and I am very grudging about the learning time they will steal away from me. Here's my proposal:

We are at a sufficiently sophisticated juncture to enter the QWERTY stage of word processing. QWERTY is not perfect, but the mere fact that it exists is a great boon. The product developers cannot produce standardized codes for the main command-, menu-, and icon-driven approaches to word, text, and knowledge processing.

I suspect you could pull it off. It is an ideal project. Start a "TextCode" workshop on BIX or on the USC Virtual Academy. Membership should include leading writers and developers.

The first task would be to work up a comparative survey of all the essential functions, manipulations, formats, fonts, and utilities of 10 leading word processors. Then an analytical comparative display could be made. This would produce a set of the codes for their commands, menus, and icons. Start with the command codes; they're the most basic. There will be some duplication. It shouldn't be hard to agree upon a standard set. Menuing systems can be considered as macros for commands. These also could be reduced to a single set in the same way. Icon systems can be considered as pictograms and symbols of macros. They could also be compared and reduced to a single set.

Then have all the developers, plus a few others, try it out for 6 months before certifying the final version.

It's not likely that developers will troop to such standards automatically. However, a transparent shell could be produced without much trouble. It would be a general-purpose TextCode utility, customizable for any word processor. The developers would soon write to its codes and develop programs using its features.

Harvey Wheeler
Carpinteria, CA

Sounds like a great idea; it's possible that we could do it on BIX. I completely agree: Karen Acerson's *WordPerfect* book is the best way to learn that one. *WordPerfect* is an editor that's more than good enough, and those who really get used to it don't want anything else.

—Jerry ■

Choosing the Right Database Development System Just Got Easier.

db_VISTA III™ Delivers High Performance With No Hidden Costs.

For database applications development, you want a system with performance, portability, and full functionality at a competitive price. But there's more to it than that. The long term costs associated with extended development schedules, frequent maintenance, excessive royalties, or the inability to handle complex data relationships are often overlooked. These hidden costs can be quite a shock after you have made a commitment and are midway through application development, or worse yet, in production.

With db_VISTA III from Raima, there are no surprises. It provides powerful database capability with tremendous overall cost savings. The heart of the system is db_VISTA, a high performance DBMS that uses B-tree indexing and the network database model file structure to minimize overhead and provide fast data access. Our SQL-based db_QUERY provides a relational view of the network structure, without sacrificing performance. And db_REVERSE lets you easily redesign your database. The entire db_VISTA III system is fault tolerant and complete source code is available.

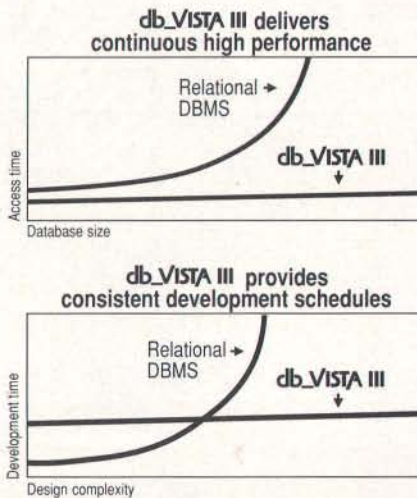

db_VISTA: High Performance DBMS

Multi-user
Fast data access: B-tree indexing, network database model, virtual memory disk caching
Multiple Database Access
Referential integrity
Automatic recovery
Record and file locking
Database consistency check
Easy-to-use interactive access programs
Data Definition Language patterned after C
db_QUERY: SQL-based Query
Relational interface to db_VISTA databases
Yields extraordinary performance
Build ad hoc queries & reports
db_REVERSE: Database Restructure Program
Redesign your database
Converts existing data to revised design
Upgrade remote end user locations easily
Add WKS Library for Lotus 1-2-3
Fast C interface to Lotus, dBASE and others
Operating Systems: VMS, ULTRIX, UNIX System V, BSD 4.2, SunOS, QNX, XENIX, OS/2, MSDOS, Macintosh, MS Windows
C Compilers: VAX, UNIX, XENIX, SunOS, Microsoft, Lattice, TurboC, LightspeedC, MPW
LANs: NFS, 3Com, NetWare, LifeNet, Banyan, and any other MS-DOS NetBIOS-compatible LAN. AppleShare and network-independent versions also.

Thousands of C programmers in over 50 countries worldwide have chosen Raima's db_VISTA III. Here are the reasons why:

- Fast data access
- Minimal data redundancy
- C source code available
- Automatic recovery
- Multi-user support
- Portable to VMS, UNIX, OS/2, MS-DOS and Macintosh
- SQL-based relational query
- No royalties
- Professional services
- Superior support

Maybe it's time that you checked out db_VISTA III. Consider *all* the costs. It could be the easiest choice you ever made.

CALL:

1-800-db-RAIMA
(that's 1-800-327-2462)

Ask about the many other products and services Raima Corporation offers, including consulting, application development, and training.

See us at
COMDEX/Fall '88
Booth 9607 Sahara Hotel
Nov. 14-18, 1988 Las Vegas, Nevada

RAIMA™
CORPORATION

DRAFIX CAD ULTRA FINALLY FILLS AN IMPORTANT GAP IN LOW-COST CAD.



Lotus 1-2-3 is a trademark of Lotus Development Corporation.
 Ashton-Tate dBASE III PLUS is a trademark of Ashton-Tate.
 WordPerfect is a registered trademark of WordPerfect Corporation.
 Microsoft Word is a registered trademark of Microsoft Corporation.
 Ventura Publisher is a trademark of Xerox.
 Aldus is a registered trademark of Aldus Corporation.
 AutoCAD is a trademark of Autodesk Incorporated.

Drafix introduces CAD for the real world. The first, inexpensive CAD software package that can turn your drawings into usable database and spreadsheet information.

New Drafix CAD Ultra with CADapult.™

CADAPULT YOUR DRAWING INTO LOTUS 1-2-3 OR DBASE.

Any CAD package lets you create drawings. Drafix CAD Ultra's CADapult utility lets you turn them into facts and figures.

First, you can give every element in your drawing specific attributes—a name, a part number, a price for example. Then, you can transfer that data into other formats.

With little more than a push of a button, you can convert the data into a spreadsheet, move it into a database or insert it into your drawing.

Suddenly your concept becomes a bill of materials, a component pricing list, an order form, a job estimate. Drafix CAD Ultra even lets you transfer files from WORD, WordPerfect and other popular word processing programs or lets you move your HPGL files to Ventura, Aldus and a variety of other desk-top publishing programs.

Whether you're designing a deck or a skyscraper, a gear or the Space Shuttle, new Drafix CAD Ultra gives you all the tools you need.

And it's still the best value in inexpensive CAD packages.

DRAFIX. THE EASIEST CAD PACKAGE YOU'LL EVER USE.

"Easy to learn and use." That's how PC Magazine described Drafix and our incredibly simple user interface. It is still one of the unique features you'll find in new Drafix CAD Ultra.

We've eliminated the need for memorization by leaving our menus on the screen all of the time.

In minutes you'll create sketches and drawings naturally and effortlessly—drawings that would require weeks of training on other CAD systems.

DRAFIX CAD ULTRA. YOU'LL GROW INTO IT, NOT OUT OF IT.

Unlike other low cost CAD programs we've taken no shortcuts. Drafix offers amazing power and sophistication for its price. All of the drawing, design and editing functions demanded by architects, engineers, drafters, contractors and other serious CAD users are included.

- Create your own symbol libraries with attributes or use our pre-attributed, predrawn symbols supplied with the package.
- Draw lines, arcs, polygons, splines and bezier curves or freehand sketch.
- Access our full complement of item and grid snaps for superior accuracy.
- Use our powerful and flexible automatic dimensioning system and crosshatching and solid fill for complex drawings.
- Take advantage of function key macros for even greater performance.
- Use the revolutionary word processing window for adding and editing text in drawings.

Plus much, much more.

And, it has depth that will let you continually expand your drawing capability.

Feature for feature, no other low cost package delivers the capabilities of Drafix CAD Ultra.

EVERYTHING YOU NEED IN A SINGLE PACKAGE.

Other low-cost packages require expensive add-on modules. There's nothing missing from Drafix CAD Ultra.

It now comes complete with DotPlotter, a General Symbols Library, Large Plotter capability and CADapult, our conversion utility that allows you to move information to Lotus 1-2-3, dBase and other spreadsheet and database programs. It even provides a variety of standard reports for easy output of Bills of Materials or parts lists. **At no extra cost!**

Or, as an added feature, you can also get our special report writing option, Drafix CAD Report.™ It allows you to design your own report format and then sort, group or summarize your drawing information in the layout that best meets your needs.

DRAFIX CAD ULTRA. A TOOL, NOT A TOY.

Drafix CAD Ultra is a serious CAD tool. Not a toy. A software package that, as one reviewer said, "you'll grow into, not out of."

It offers all of the 2-D capabilities and features you'll need in the future, at a price you can live with today.

And it comes complete with DotPlotter, our Symbols Library and CADapult.

You can spend a little less for CAD software. But you'll be buying a lot less performance.

EUROPEAN VERSION AVAILABLE SOON!

Fill in the gap in your CAD capability with Drafix CAD Ultra. Our European version will be available soon, and we welcome inquiries from distributors.

Circle 132 on Reader Service Card (DEALERS: 133)



*Optional

Manipulate Drafix CAD Ultra drawing data using Lotus 1-2-3, dBase III and other powerful spreadsheet and database applications.



Our Dynamic Screen Menuing System™ makes drawings like this a snap, even for first time users.



Drafix offers features the most sophisticated user will appreciate.



FORESIGHT RESOURCES CORP.
10725 Ambassador Dr.
Kansas City, MO 64153
816-891-1040

Lotus 1-2-3

For IBM Personal System/2
Models 30, 50 & 60
IBM PC Compatible, plus
1-2-3 Certified Compatible
with 3.5" disk drives.
See System Requirements.

ASK BYTE

Circuit Cellar's Steve Ciarcia answers your questions on microcomputing

The High Cost of a UPS

Dear Steve,

I have been musing for a long time about the high cost of an uninterruptible power supply (UPS) for microcomputers.

It seems that much engineering (or marketing hype) is spent on making a quick switch from AC to inverted battery power. Why switch? Why don't the manufacturers just run the inverters all the time? They already have a battery-charging circuit designed in.

I also think it would be much better to replace the original power supplies entirely. The UPS replacement supply does not have to be the same size as the original power supply, although that would be nice. The internal UPS just needs to be able to run off batteries that get charged by the AC line. Why not just have a large plug on the back for heavy cables to run to some suitable batteries?

Those who think saving their work "blind" isn't acceptable could buy an additional car-battery-driven AC inverter to be used to power CRTs.

This leads me to realize that between the rectification and regulation stage of all power supplies, even switching ones, there is always a capacitor bank. It seems to me that the proper number of gel-cell-style batteries would provide an excellent number of extra farads. Can't batteries be kept charged by the existing supply circuitry, and wouldn't their current be used instantly if the AC power went off for short periods? The batteries might also provide some protection against power spikes.

Could you publish a short article that would detail the exact kind of batteries to use and where to connect to existing IBM PC or Macintosh power-supply circuitry? Since there may be a power-up timing sequence to the multiple voltages, a delaying relay might be used to bring the batteries into the circuit after the power supply establishes the proper voltages.

A companion project could be a car-battery-to-AC inverter for a CRT. Couldn't two high-current field-effect

transistors (FETs) be used to produce a modified square-wave supply?

K. Kenneth Clark
Garden Grove, CA

Complete answers to all the questions you've raised could fill at least one good-size textbook. With UPSes, there are trade-offs piled upon trade-offs in each design. Given certain goals, the engineers do the best they can with the design. There are few, if any, ideal solutions; the real world is a place of compromises, and UPS design is no exception.

IN ASK BYTE, Steve Ciarcia, a computer consultant and electronics engineer, answers questions on any area of microcomputing and his Circuit Cellar projects. The most representative questions will be answered and published. Send your inquiry to

Ask BYTE
One Phoenix Mill Lane
Peterborough, NH 03458

Due to the high volume of inquiries, we cannot guarantee a personal reply. All letters and photographs become the property of Steve Ciarcia and cannot be returned.

The Ask BYTE staff includes manager Harv Weiner and researchers Eric Albert, Tom Cantrell, Bill Curlew, Ken Davidson, Jeannette Dojan, Jon Elson, Frank Kuechmann, Tim McDonough, Edward Nisley, Dick Sawyer, Robert Stek, and Mark Voorhees.

It is useful to divide UPSes into two types—part-time and full-time—and discuss them in that context. A part-time UPS consists essentially of a battery, a charging circuit, an inverter to convert DC to ersatz AC, and a switching circuit to detect power failure in the supply line. The battery is kept charged, and in the event of power failure on the line, it supplies backup power to the system via the inverter. A full-time UPS always powers the computer. Main power serves only to charge the batteries, which, in turn, always power the computer.

Most of the currently available UPSes are of the part-time variety. Part-time

systems are more efficient than full-time systems, requiring fewer conversions in normal use. A full-time UPS also requires more robust components, better cooling, and more careful design than a part-time unit.

Your suggestion that the backup batteries supply DC power directly, without the DC-to-AC-to-DC roundabout, is a sound one, and it's by far the most efficient method, since it avoids multiple conversions. Installation and use of such a unit, however, is another story. You'd need either a special connector or cable to supply system power, or else some board surgery, and perhaps both. In a world that is dominated by appliance users who think anything more complex than a toaster is too difficult to use, a marketable UPS is one that computer users can just plug the computer into and run. That means AC power, just as if it were coming out of the wall. The January 1988 issue of Radio-Electronics features a construction article for a 40-watt UPS of this type.

If the capacity of the computer's built-in power supply were great enough to power the computer under worst-case conditions and charge the batteries, your proposal for a backup system could work. The biggest problems are where to put the battery or batteries, and the modifications that would need to be made to the computer. A separate small PC board might reduce the second problem.

A minimum homebrew DC-only UPS could consist of a car or motorcycle battery and float-charger, a few regulators, and a means of detecting power failure and switching on the backup battery. The switching circuit could be as simple as a few diodes and capacitors (similar to what is used in the battery backup circuits for clock/calendar circuits) or something more elaborate, such as a series-pass transistor switched by a comparator.

A simple square-wave inverter, as you suggest, should be capable of faking squared-up AC for a monitor, but the monitor should agree to the deal in advance. I'd want to heat-sink the FETs

continued



These unretouched print samples show the superior print quality of QMS-PS 810 over printers using first-generation print engines.

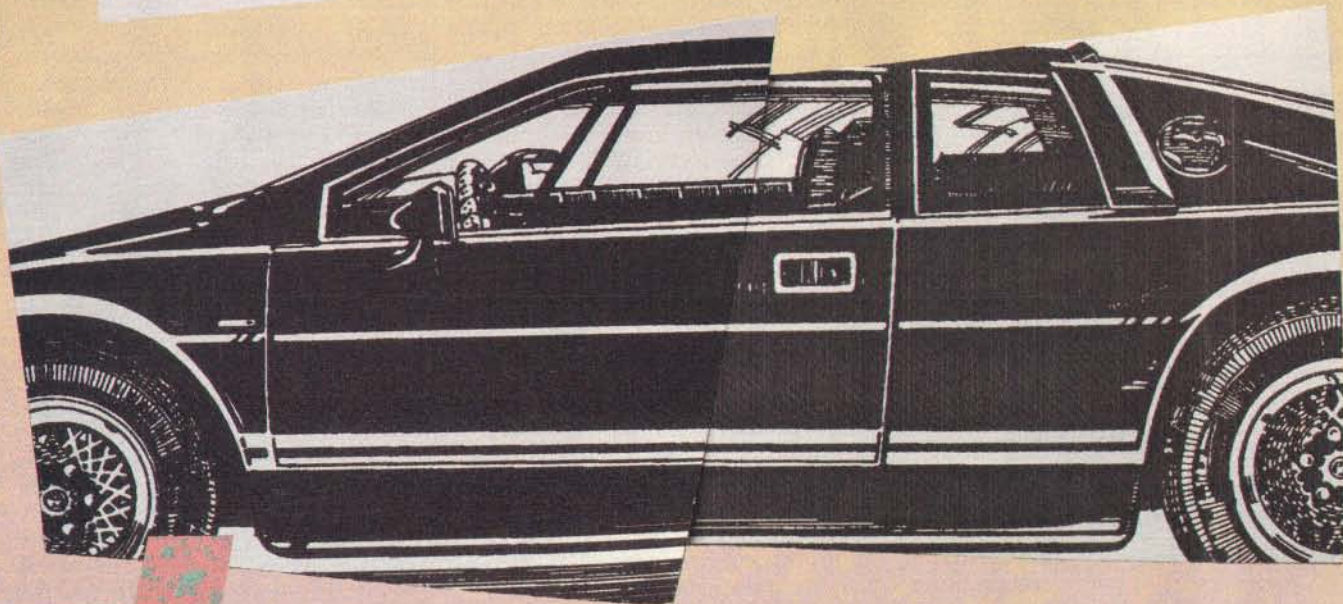

Introducing the PostScript laser printer that blacks out at high speeds.

The new QMS-PS[®] 810 can compose and print the most complex pages in record times, with richer, more saturated blacks than ever before. All with the desktop publishing power of Adobe PostScript[®], and the superior print know-how of QMS, an industry leader.

Under the hood QMS ASAP[™] (Advanced System Architecture for PostScript) is proprietary technology that helps eliminate the hardware bottlenecks that hinder other PostScript printers. As a result, QMS-PS 810 boasts processing speeds remarkably faster than other PostScript printers in its class. And faster output means greater productivity. In addition, the QMS-PS 810 laser

printer's new Canon[®] SX[®] print engine covers solid areas and prints fine detail better than previous-generation engines.

Fast start, strong finish You can adorn your documents with one or all of the 35 Adobe typefaces. Thanks to PostScript, there's an infinite number of font variations available. You can also make type as large or as small as you want. And put it anywhere on the page. In fact, with PostScript you enjoy total control over the design of your page. It gives you the complete desktop publishing power to do things that would otherwise be virtually impossible. So you get high-quality output exactly how you want it.

Along with PostScript, the HP LaserJet+[™], Diablo[®] 630 and HP-GL[™] printer emulations are added for your non-PostScript software.

The QMS-PS 810 laser printer is easy to use, maintain, and comes with a one-year warranty. It's available from Laser Connection dealers. Laser Connection is a sales and marketing subsidiary of QMS. For the dealer nearest you call **1-800-523-2696**.

**The new
8-page/minute
QMS-PS 810
laser
printer**



**LASER
CONNECTION[™]**

A QMS[®] company

The following are trademarks of their respective companies: QMS, QMS-PS, ASAP, Laser Connection of QMS, Inc. PostScript of Adobe Systems, Inc. Canon, Canon SX of Canon, U.S.A. LaserJet+, HP-GL of Hewlett-Packard. Diablo of Xerox Corp.

Integrand's new Chassis/System is not another IBM mechanical and electrical clone. An entirely fresh packaging design approach has been taken using modular construction. At present, over 40 optional *stock* modules allow you to customize our standard chassis to nearly any requirement. Integrand offers high quality, advanced design hardware along with applications and technical support *all at prices competitive with imports*. Why settle for less?

Rack & Desk PC/AT Chassis

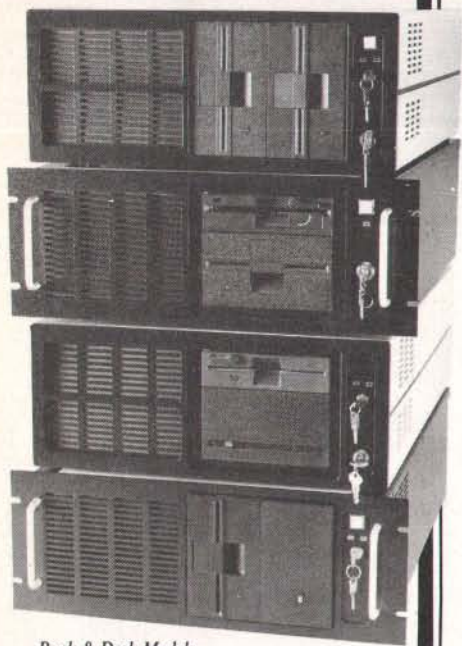

Rack & Desk Models

Accepts PC, XT, AT Motherboards and Passive Backplanes

Doesn't Look Like IBM

Rugged, Modular Construction

Excellent Air Flow & Cooling

Optional Card Cage Fan

Designed to meet FCC

204 Watt Supply, UL Recognized

145W & 85W also available

Reasonably Priced

INTEGRAND

RESEARCH CORP.

Call or write for descriptive brochure and prices:

8620 Roosevelt Ave. • Visalia, CA 93291

209/651-1203

TELEX 5106012830 (INTEGRAND UD)

EZLINK 62926572

We accept BankAmericard/VISA and MasterCard

IBM, PC, XT, AT trademarks of International Business Machines. Drives and computer boards not included.

ASK BYTE

well and have a fan blowing air across the heat sink(s), though. It would be simpler to use a monitor that runs directly from DC power. Outfits like B.G. Micro advertise such monitors regularly in publications like Computer Shopper.

I'll keep your ideas in mind for future Circuit Cellar projects both in BYTE and Circuit Cellar INK. Over the years I've gotten much good inspiration and many interesting ideas from readers and fans such as you. If only I had the time to pursue them all!—Steve

Acer in the Hole

Dear Steve,

I have a problem that I can't seem to resolve. It concerns addressing the 128K bytes of RAM used on the IBM bus to address ROM on the I/O boards.

My system is an Acer 1100 (an 80386 machine) with 1 megabyte of RAM on the motherboard, an Acer MFB-AT memory expansion card with 1.5 megabytes of RAM, a Franklin 60-megabyte internal tape backup, a Micro Display Systems Genius full-page display, a LaserMaster CAPCard printer card for the Hewlett-Packard LaserJet Series II printer, a Western Digital WA-2 floppy/hard disk controller card, and an HP ScanJet Scanner. As you can see, I have been trying to put together a usable desktop publishing system to run Ventura Publisher.

The problem I'm having is that the system locks up occasionally.

To date, I have verified that the power supply and cooling systems are adequate. The computer is connected to a constant-voltage conditioned power loop specifically dedicated to our data processing equipment, grounding (I'm using a 4-wire separate chassis ground system), static protection, static mats, and so on. For cooling, I've installed an external auxiliary cooling fan. Nothing has solved the problem.

At this point, Xerox says it must be the hardware; the hardware people say it must be the software. I have determined that the machine has no conflicting addresses in the I/O address area, and there are no conflicting interrupts.

As I have gotten deeper into this issue, on occasion I have noticed mention of the 128K-byte expansion ROM area. Hewlett-Packard discusses this at some length in its ScanJet Scanner manual. The MDS Genius Display manual also talks about it. Unfortunately, no one else (ACER, Franklin, etc.) has been able to tell me if they use this memory and, if so, what addresses they use. If this is an area of potential conflict between expansion de-

vices, I would think that anyone who makes an expansion card would discuss it in the manual; at least, the technical support people should be informed. Do you know where I can get this information? I'd like to be sure I have no conflicts with these devices. Evidently, this type of problem can be very subtle. I know I've spent untold hours of frustration and still don't know what to do.

Herald S. Harrington
Jerome, AZ

I don't have any technical data on the Acer, so all I can do is make an assumption that things are put in the same places as they are in an IBM PC or AT. If you had two active ROMs installed with overlapping addresses, your problems would not be occasional; the most likely effect would be a failure to boot. Incidentally, one address you should investigate is the hard disk BIOS. This starts at segment C800h, just above the display-board BIOS area.

If you have a hardware problem, it could be a slow memory chip or peripheral board that occasionally gets out of sync. This can cause intermittent problems of the type you describe. Sometimes you get a parity check message with this type of problem, and sometimes you don't. The type of problem you describe could be caused by software with a bug that causes it to write to memory that is being used by DOS or other resident programs.

One thing that bothers me is your use of a 16-bit memory-expansion board in the 32-bit Acer 1100. The Acer uses an interleaved memory scheme of some type, probably for speed, and it's probably similar to that used in some models of the Compaq 386.

I suggest you perform some diagnostic tests to isolate the problem. First, temporarily delete any resident programs—SideKick, keyboard enhancers, pop-up calculators, and so on. Revise your AUTOEXEC.BAT and CONFIG.SYS files so that you boot with only the drivers and resident programs that are absolutely needed. If the problem goes away, start adding the things you removed, one at a time, until the problem reappears.

If eliminating the unnecessary software doesn't solve the problem, you'll have to start removing hardware. Start by removing the memory chips on the AT expansion card and setting the switches (if any) to indicate zero memory. The output ports on this board should not cause problems unless one is defective, so you shouldn't have to remove the board yet.

continued

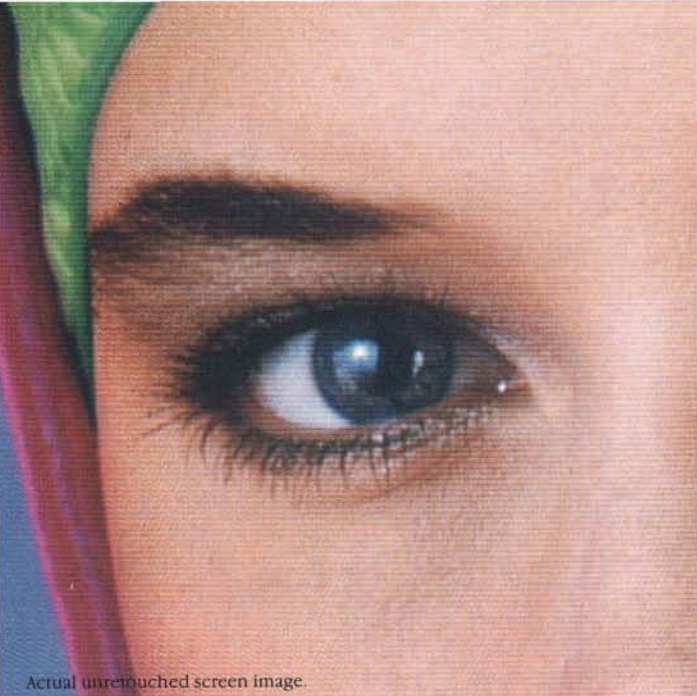

Actual unretouched screen image.

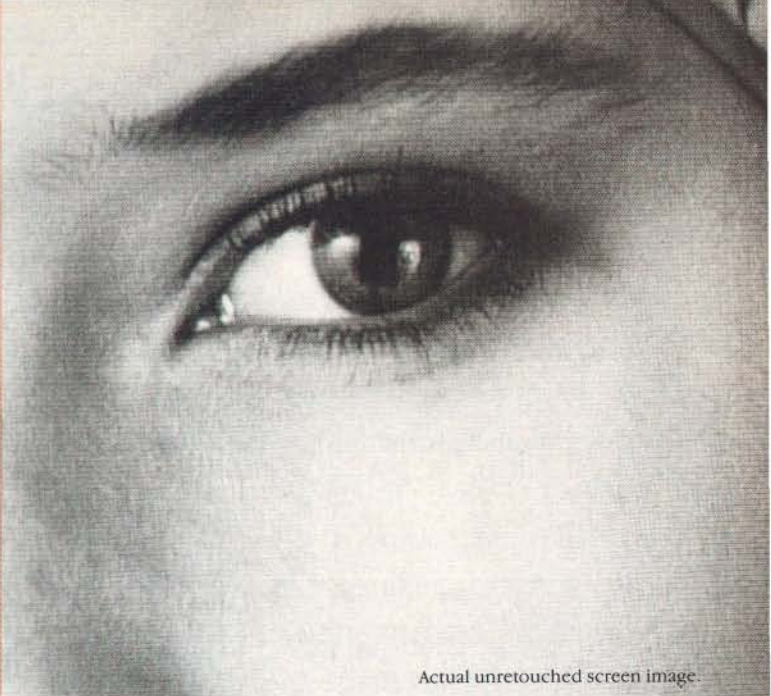

Actual unretouched screen image.

Screen stars with The Visible Edge.

What gives Princeton's new generation of screen stars the Visible Edge is a screen image of incomparable clarity and resolution. Where brilliant colors and infinite shades of gray, with striking contrast and dimension, are commonplace.

The versatility of the Princeton family of monitors gives the new generation (and present generation) of computers, the greatest autosynchronous horizontal/vertical scan range combination available (ULTRASYNC and MAX-15). The clarity of .28mm dot pitch (ULTRASYNC and PSC-28). 1024x750 display resolution (MAX-15). And the entire spectrum of color, with the ease and comfort that can only accompany an ergonomically designed monitor.

Experience a world of unlimited vision. And the technology that's made our high level of quality, service, value and performance, second nature. Experience the Visible Edge. And see what we do best. For more information call (609) 683-1660 x 100.

PSC-28



PSM-03



ULTRASYNC



MAX-15



Compatibility: IBM PC, XT, AT, PS/2, Apple Macintosh SE

Compatibility: IBM PC, XT, AT, PS/2, Apple Macintosh II, SE

PRINCETON
GRAPHIC SYSTEMS
THE VISIBLE EDGE

601 Ewing Street, Building A, Princeton, New Jersey 08540 (609) 683-1660

Circle 260 on Reader Service Card

Thanks to PageStyler, the add-on board that lets you print Macintosh-quality graphics on your HP LaserJet printer.

Now you can make your newsletters more attractive, your reports more professional and your presentations more powerful just by installing PageStyler® on your IBM PC/AT or compatible.

It works by adding a fully compatible implementation of the PostScript® language used by the most advanced software and laser printers to deliver their amazing graphics.

You can print finer lines, smoother curves and more detailed gradations than ever before on your HP LaserJet, Acer LP76, and Canon LBP printers. You can handle full-

THE DAILY

COFFEE SALES ARE JITTERY THIS YEAR

The coffee industry would appreciate it if you drank another cup while you're reading this.

According to the latest figures from the Coffee Council, sales of unroasted coffee beans are in a bit of a slump.

"It's been a slow year for the coffee growers", said Bob Porter, director of the council. "We're seeing a trend away from drinking five to six cups a day, to just two or three. Nobody's panicking, but there is definitely a trend."

Coffee consumption hit an all-time high in the

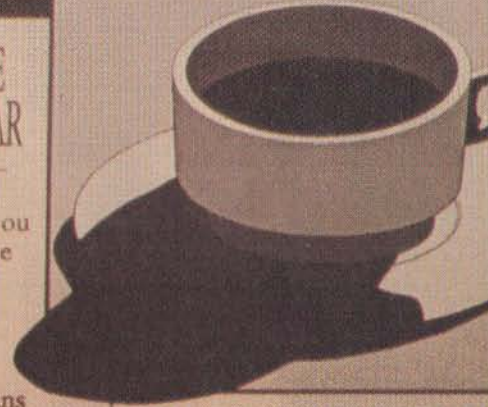

REAL COWBOYS DROP AN EGGSHELL INTO THE POT.

When that cold winter wind sweeps down over the north 40, and the wolves

howl outside

your door, a demitasse of espresso just doesn't cut it.

You need something that's going to warm you right



Coffee beans contain less than one gram of oil each



HEWLETT
PACKARD *LaserJet series II*

WARNING: NO VERY GRAPHIC

CUP

former art director in an advertising agency, Houk left the business to do "some real man's work."

"Out here, coffee's more than just something you drink. It's a way of life. It's got to be strong, it's got to be hot, and it better not be full of grounds.

That's u add shell. the the ght to tom." uk is

nout ming his ee, he's uctant to part with the s it so



The coffee plant ranges from five to ten feet high.

page graphics, change fonts, expand and contract characters, and take advantage of all the capabilities of PostScript-driven software. And PageStyler works as well on a network as it does on a single PC.

Use it with all the most popular programs, like Ventura Publisher, PageMaker, Harvard Graphics, WordPerfect 5.0, Microsoft Word, Excel, Manuscript, The Office Publisher, and AutoCad Release 9.

When the new Adobe Illustrator™, Xerox Cricket Draw, and Aldus Freehand programs are available, PageStyler will give you everything you need to use all their capabilities.

And when you don't need graphics, it automatically

switches your laser printer back to printing letters and numbers the same sharp, fast, quiet way it always has.

PageStyler comes complete with 13 type fonts (with 22 more available), 2.5MB of memory (upgradeable to 4.5MB), a very helpful user utility, and a comprehensive set of user manuals.

All at a very affordable price.

If you'd like to see how much

your image will improve when you slip Page-

Styler into your PC, call today for our very graphic brochure. We'll send it in a plain brown wrapper. 1-800-874-5553 (in California, call 415-537-9044).



Circle 101 on Reader Service Card

See us at Comdex Booth W272.

DESTINY

Destiny Technology Corporation
300 Montague Expressway, Suite 150
Milpitas, CA 95035
FAX (408) 262-0221

HOW CONTAINS C LANGUAGE.

Listing 1: Reading the joystick port in GWBASIC.

```

100 'Joystick STICK function demo
110 LOCATE 9,1: PRINT "JOYSTICK A";
120 LOCATE 10,1: PRINT "XA = ";
130 LOCATE 11,1: PRINT "YA = ";
140 LOCATE 9,20: PRINT "JOYSTICK B";
150 LOCATE 10,20: PRINT "XB = ";
160 LOCATE 11,20: PRINT "YB = ";
170 TEMP = STICK(0) 'READ JOYSTICK
180 XA = TEMP 'COPY THE FOUR VALUES
190 YA = STICK(1) 'INTO FOUR VARIABLES
200 XB = STICK(2) 'AND PRINT THEM
210 YB = STICK(3)
220 LOCATE 10,15: PRINT USING "###"; XA;
230 LOCATE 11,15: PRINT USING "###"; YA;
240 LOCATE 10,35: PRINT USING "###"; XB;
250 LOCATE 11,35: PRINT USING "###"; YB;
260 A$=INKEY$ 'LOOP UNTIL A KEY
270 IF A$ = INKEY$ GOTO 178 'IS PRESSED
280 END

```

The next thing to remove is the Laser-master card. Not that you don't need it, but it is a possible source of conflict until you know more about it, and you can at least run the computer without it.

If you follow this procedure far enough, you should find the problem. It's time-consuming and not much fun, but in the absence of several kilobucks' worth of diagnostic equipment, it is usually the only way to find the culprit.—Steve

A Sticky Question

Dear Steve,

I have a question concerning programming in GWBASIC. How do you use the STICK() function to access the joystick? If you can, please provide me with a sample program.

Garth H. Brantley
Baltimore, MD

The program in listing 1 reads an x,y coordinate pair from each of two joysticks and prints the results in a table on the screen as the program continuously tracks the positions of both sticks. There is really only one tricky feature to this: It's in line 170, where STICK(0) is read. This returns all four stick values to the variables STICK(1) for 1 = 0 to 3, so all four values are determined simultaneously.—Steve

Game-Playing Junkie

Dear Steve,

I'm a game-playing junkie. I want to learn how to write game programs—not to sell, but as a personal challenge. I'm also a novice programmer. The only language I own is Microsoft QuickBASIC 4.0. My interest in games ranges from

Stargate (Atari public domain) to Sesame Street Pals Around Town (Hi Tech Expressions) for the kids. What can I read that will give me good information on how to write game programs?

Gail Nolf
Hellertown, PA

Get The Art of Computer Game Design by Chris Crawford (Osborne/McGraw-Hill, 1984). It will give you insight into how to design a game, as distinct from the actual gritty details of implementing one on any particular system. You'll find that there's more to a simple game than meets the eye.

Once you've decided what the game should do, it's time to write the code that makes it work. For that, you'll need detailed information on the particular computer system that you're using. A good game will stretch the system, particularly the video hardware, to its limits. Get all the books you can find on the system and read all of them, because knowing just one fact can often make the difference between success and failure.

IBM PCs, unfortunately, don't have good built-in support for arcade-quality video or audio. Unlike the Ataris and Amigas, the IBM has no hardware for manipulating graphics images; and unlike the Mac, it has no Toolbox routines to help you out. You'll have to do it all by hand.

If you're tackling an IBM PC, be sure to get Richard Wilton's Programmer's Guide to PC and PS/2 Video Systems (Microsoft Press, 1987), which will tell you everything you need to know about writing serious down-and-dirty code to make the best of the video hardware.

Apart from that, pick up any of the better books that delve into hardware details. You may pick the wrong ones, but if you get enough, you'll be able to glean the essentials. Skip the junk that tells you how to use DOS.—Steve

Hi-Res on Hercules

Dear Steve,

I am involved in research that requires high-resolution graphics, so I plan to write assembly language routines for the Hercules monochrome graphics card.

What are the commands to turn on the 720-pixel by 348-pixel graphics mode? I understand the card has 32K bytes of video RAM starting at B000h. My guess is that it is divided into four banks of 8K bytes each.

I've heard that through special programming techniques, you can get a 720-pixel by 350-pixel graphics display. Is this possible?

Meng Heng
Penang, Malaysia

On a Hercules card (or compatible), these 8088/8086 I/O ports are used:

- 3B4—6845 address register
- 3B5—6845 data register
- 3B8—Display mode control port
- 3BA—Display status port
- 3BF—Configuration switch

There are other ports used for a printer interface and serial interface (if present), but they have no effect on the display.

To understand the card's operation, consider the two operating modes: text and graphics. In text mode, the video comes from the 6845 display controller, a character-generator ROM, and an attribute circuit (for controlling blinking, underlining, and normal and reverse video modes). In graphics mode, the pixels come directly from the video buffer.

There are two pages of 32K bytes each, for a total of 64K bytes of display memory. In the graphics mode, each horizontal line of 720 pixels is stored in the buffer as 90 consecutive bytes, with bit 7 as the leftmost bit on the screen. Each page is divided into one line from field 0 and then goes to fields 1, 2, and 3. This sequence continues for the entire screen, so adjacent lines from the same field are displayed four lines apart on the screen.

The offset (into the page) of the byte containing pixel x,y in each page is expressed as follows:

$$2000H * (Y \text{ MOD } 4) + 90 * \text{INTEGER}(Y/4) + \text{INTEGER}(X/8)$$

continued

TALLGRASS BACKS YOU ALL THE WAY.



*Tallgrass makes
internal and external
tape backup systems
for the IBM PC/XT/AT,
PS/2 or compatibles,
and an external
unit for your Mac
Plus, SE or II.*

We've got a whole new family of tape backup systems.

Whether you've got an IBM, a compatible, or a Macintosh, you can count on Tallgrass. We back you with all the storage capacity you could ask for, plus all the features, all the support, and all the speed you'll ever need. And we make it easy to protect your valuable data. Since all operations are automatic

and unattended, you can just set it, and forget it.

Best of all, we stand behind our products with the industry's only 3-year warranty.

But there's one other reason why so many more people are asking for Tallgrass. It's because the competition is asking so much more for their products.

Let Tallgrass start backing you up.
Call 1-800-TAL-GRAS. Or write to:
Tallgrass Technologies, Inc.
11100 West 82nd St.
Overland Park, KS 66214

 **TALLGRASS
TECHNOLOGIES**

When it's worth saving, it's worth Tallgrass

© 1988 Tallgrass Technologies, Inc. "IBM" is a registered trademark of International Business Machines, Inc. "Macintosh" and "Mac Plus" are trademarks of Apple Computer, Inc.

COME SEE US AT COMDEX FALL BOOTH W1068

ASK BYTE

Finally . . . a low cost, high speed copier for 5¼ and 3½ inch diskettes!

Attach a Victory V3000 Autoloader to your IBM/PC or Apple/Macintosh, enter one or more copy jobs, and walk away! The system automatically copies 5¼ or 3½ inch diskettes—up to 180 per hour. Switching the copy drive takes less than two minutes.

Copy Formats Flawlessly.
Victory's Auto-Dup™ software copies different formats or you can

build your own format. Auto-Dup tests the quality of each copy, sorting diskettes into one of two output bins.

Do-It-Yourself Servicing.
The Autoloader's simple component design and diagnostics for checking drive alignment and speed allow you to maintain the system without outside service.

Call (800) 421-0103. And ask about Victory's family of affordable Autoloaders that support

Hard Drive Back-Up, Serialization, and Custom Label Printing.



VICTORY ENTERPRISES

Technology, Inc.

Victory Plaza
1011 E. 53½ Street
Austin, TX 78751-1728
(512) 450-0801

In Europe call BPE: Paris (33-1) 4330137, Frankfurt (49-6074) 27051, London (44-1) 941-4066, Milan (39-2) 33100535, Stockholm (46-8) 7547460, Madrid (34-1) 2559503.



PERMA POWER FIGHTS SURGES TWO WAYS . . .

OR WE PULL THE PLUG

Perma Power Surge Suppressors give you peace of mind, knowing that your computer is protected against power line surges and against suppression element failure.

PROTECTION FROM POWER LINE SURGES

Our unique 2-stage circuit uses heavy-duty metal oxide varistors to protect you against high-voltage lightning-induced surges, and high-speed semiconductor devices to protect against frequent fast surges. Only this kind of hybrid circuit can provide the necessary high power dissipation while still providing fast response time and low let-through voltage.

PROTECTION EVEN IF WORN OR BURNED OUT

Any surge suppressor can wear or burn out. With Perma Power you can relax! Power to your system is stopped . . . as completely as if the plug was disconnected. Other surge suppressors may use a light or buzzer "warning," while they continue to let raw, unprotected power feed directly into the computer. Only with Perma Power's patented Automatic Shutdown* feature is your equipment kept safe from damaging raw power.

Ask for Perma Power Extended Life Surge Suppressors, in 2, 4, or 6 outlets and Power Control Center models to insure your computer is being protected. At office, computer or electronics dealers nationwide.



*Patent #4,578,579

PERMA POWER®
Electronics Inc.

5601 West Howard Avenue • Chicago, Illinois 60648
Telephone (312) 647-9414

The bit in the bytes that stores the dot is at position

7 - (X MOD 8).

You select the mode by writing a 1 into bit position 1 of the display mode control port (3B8). Bit 3 gates the video on and off, bit 5 enables blinking characters in text mode, and bit 7 selects the memory page. Bits 0, 2, 4, and 6 are not used.

While you can fool some boards into displaying the last two lines (349 and 350), you can't fool them all. Therefore, I suggest that, given the marginal utility of two additional pixels in the vertical interval, it's really not worth attempting to use them.

A number of public domain packages interface to the Hercules card quite nicely, but I don't know what's available in Malaysia. If there is an IBM PC user's group nearby, you might inquire there.
—Steve

Racehorse or Relic?

Dear Steve,

Recently, I was given an old computer system gratis. I received a huge 132-column printer, a Bell-compatible modem, several disks that appear to contain utilities, and the main system. The main system consists of a case containing an 8-inch green-phosphor monitor and two 8-inch disk drives. The keyboard plugs into a card inside the case, as do the modem and the printer. The name on all the equipment is Sycor, Inc., and the date stamped inside the computer case is 12/23/78.

My problem is twofold. First, I have no idea what this thing that takes up floor space is; and second, I don't have the documentation. Consequently, I can't tell whether it is junk or usable.

Matthew Lunsford
Russell Springs, KY

One of the more obvious features of a field like microcomputers is the never-ending obsolescence of otherwise useful equipment.

Older items from obscure manufacturers are especially prone to fall victim because of lack of support and software development. While you may be able to obtain information or documentation for your system by advertising in or writing letters to publications like Computer Shopper, the system you have is likely to be hopelessly out of date.

At best, it is probably an interesting curiosity (or a large paperweight), rather than a genuinely useful computer system.
Sorry. —Steve ■

"An exceptional value."

Tom Badgett, *PC Clones*

"I was impressed.
It wins the cost-effective award."

John Dvorak, *PC Magazine*

"This program has all the features and capabilities of money management programs costing 10 times as much."

Leonard Hyre, *PCM Magazine*

We appreciated those kind words. They helped make **MONEYCOUNTS® 4.0** one of today's most popular accounting/money management programs for home and business. But we couldn't leave well enough alone. So we're introducing new

MONEYCOUNTS® 5.0 ...an unbelievable buy at just \$29!

MONEYCOUNTS® 5.0 balances your checkbook... prepares your budget... manages your cash, checking, savings, credit cards... prints 5 types of financial statements including net worth...3 types of inquiry reports... general ledger, accountant's trial balance, and graphics. Its fast financial data base handles up to 999 accounts and 100,000 transactions a year.

MONEYCOUNTS® 5.0 is a CPA-designed money management/accounting system you can use for home or business. It's easy to use, requires no accounting knowledge, is menu-driven with on-line help, has a fast financial calculator, works with monochrome or color monitors, comes with a **printed manual** and is **not copy protected**.

SAME DAY SHIPPING. Order today and own **MONEYCOUNTS® 5.0** for only \$29! Add \$5 shipping/handling (outside North America, add \$10). Iowa residents please add 4% sales tax.



375 Collins Road NE
Cedar Rapids, IA 52402

MONEYCOUNTS® 5.0 now also...

- prints any type of pin-feed check and updates your records automatically
- estimates your 1988 income tax
- analyzes financing options, savings programs...computes interest rates, loan payments...prints amortization schedules
- manages mail lists—zip and alpha sorts—and prints labels and index cards
- provides password protection, fiscal year support, and pop-up notepad.



VISA, MASTERCARD & COD ORDERS CALL

1-800-223-6925

(In Canada, call 319/395-7300)



Dept. B
375 Collins Road NE
Cedar Rapids, IA 52402

MONEYCOUNTS®
VERSION 5.0
\$29 + \$5 shipping

NAME _____
ADDRESS _____
CITY _____
STATE/ZIP _____ PHONE _____
CHECK MONEY ORDER VISA MASTERCARD
CARD # _____ EXP. DATE _____

No. of Copies	Product	Price Each	Total
	MONEYCOUNTS® 5.0 (Needs IBM or compatible computer, at least 256k memory, DOS 2.0 or more, two disk drives or hard disk)	\$ 29.00	
	Shipping & Handling	\$ 5.00	\$ 5.00
TOTAL AMOUNT			\$ _____

Our newest soft like the software

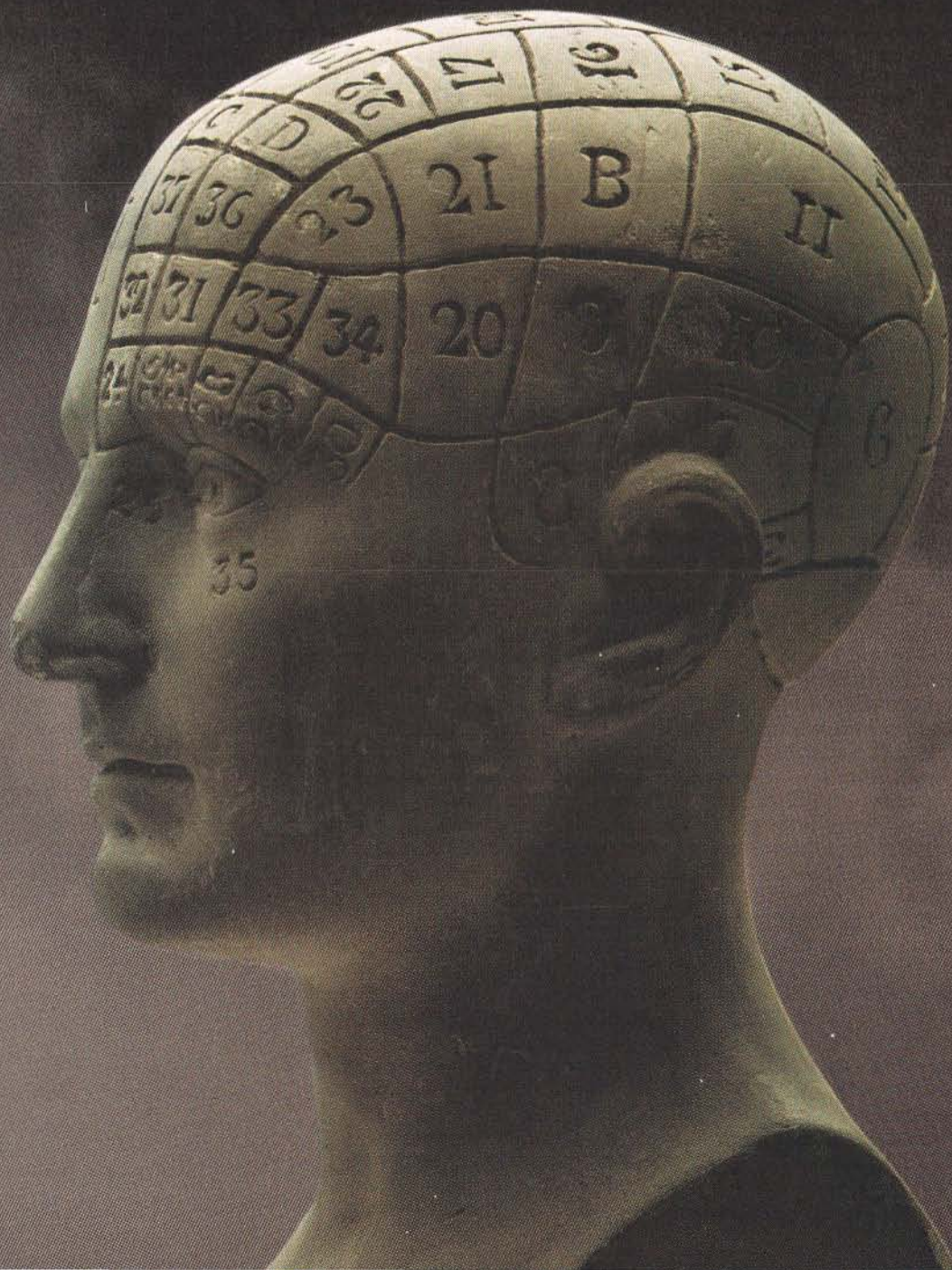

ware works just you're using now.

We've always thought that one of the biggest problems with personal computing is that a computer doesn't process information the same way that a person processes information.

And in the struggle between the two, the computer usually wins.

Enter the Lotus® Agenda® personal information manager.

Agenda's flexible design lets you dump facts and ideas into your PC without structuring them in advance.

You can arrange the information any way you want. So you can gain

insight, formulate new ideas, and find answers you need. And as a result, manage projects, people and information better.

How does Agenda work? First, enter items of information into Agenda.

Then create categories where you want all the information to be filed.

Introducing Lotus Agenda

Voilà. Agenda will do all your filing automatically. And if an item is relevant in more than one place, Agenda will put it in several categories at once.

What's more, if you change an item

anywhere in your file, all other categories that have the same item will also change automatically.

File: C:\AGENDA\FILES\ISSUES 09/21/88 11:00			
View: Issues by Person			
Issues	Joan	Priority	When
• Research	• Decision needed on research budget by end of this week-- discuss options with Jim and Joan.	• High	• 09/25/88
• Competitive Tracking	• Forward product comparison articles to Joan.	• Low	• 07/07/88
Issues	Bob	Priority	When
• Distribution	• Do Tom and Bob think we need to adjust distribution mix?	• High	• 09/22/88
• Bonus Dollars	• Bob will present ten-point incentives program at sales conference.	• Medium	• 09/29/88

Agenda automatically files items in all relevant Categories. Then you can View information from different perspectives.

This makes it easy to view evolving data in different ways so you can discover new relationships and pinpoint information that's important to you.

For \$15, we'll send you an Agenda demo kit or videotape. Just call 1-800-345-1043 and ask for demo kit AGV-3058 for the 3.5" version or AGV-3053 for the 5.25" version, or you can ask for AGV-3063 for the videotape version.

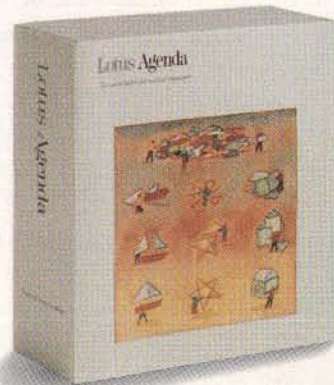

File View Item Category Print Utility System Quit New, Remove, Position, Assign, Discard, Undiscard		
Scratchpad	Who	Issues
• Forward product comparison articles to Joan.	• Joan	• Competitive Tracking
• Can we get the cost of goods sold under \$12?	• Tom	• Materials
• Bob will present ten-point incentives program at sales conference.	• Bob	• Bonus Dollars
• Tom will have his report in by a week from Friday; make sure it covers pricing, strategy, distribution, and implications of using outside vendor for typesetting and printing.	• Tom	• Distribution Vendors Pricing
• Decision needed on research budget by end of this week--discuss options with Jim and Joan.	• Jim • Joan	• Research

Enter items of information manually, import them electronically, or use the pop-up capability while in another program.

VGA WUNDER™

1024X768

plus: VGA EGA MDA HERCULES on: STANDARD MULTISYNC monitors

Yes! the Phenomenal VGAWONDER does it all at IBM Hardware level compatibility with automatic monitor detect and no dip switches or jumpers to set. A HOT CARD for the 286/386 POWER USER with AUTO BUS DETECT for 8 or 16 bit slots, running with a 16 bit datapath with 1:1 interleave. 100% IBM HARDWARE LEVEL COMPATIBILITY means that ALL software and operating systems designed for IBM systems will run. 1024 WILL BE DISPLAYED IN COLOR ON STANDARD MULTIFREQUENCY MONITORS.

Although these features are expected from ATI they are NOT AVAILABLE from other manufacturers. EGA on all monitors including RGB & TTL means a perfect card for networks. MOUSE ON BOARD! ATI built the mouse right in to this one, why not? No extra charge! 16-bit datapath for those FAST speeds required at high resolutions. VGAWONDER is available in both 512K and 256K Versions. Ask your dealer for more information.



See us at
COMDEX/Fall '88
November 14-18, 1988
Las Vegas Hilton Hotel
Las Vegas, Nevada
Booth 7050

SUGGESTED LIST PRICE

\$499.00

VGA WONDER with 256K Video Memory



NOW SHIPPING

Software		
	RESOLUTION	COLOR/SHADE/SPECTRUM
ATI HI-RESOLUTION DRIVERS SUPPLIED	1024x768 980x720	16/256 K
ATI HI-RESOLUTION DRIVERS SUPPLIED	800x600 640x480	256/256 K
VGA	320x200 ALL 17" MODELS	256/256 K
EGA	640x350	16/64
CGA	320x200	16/64
MDA	720x348 640x480	



LINES OF TEXT	132x44	132x25	132x44	132x60	132x80	132x80	132x80	132x60
	TTL	RGB	EGA	MULTISYNC ANALOG	IBM 8503/12/13	MULTISYNC XL/PLUS	IBM 8514	
	Monitor							
	DIGITAL				ANALOG			

*800x600 CANNOT BE DISPLAYED ON 8503-12-13



TECHNOLOGIES INC.

Technology you can Trust.

ATI Technologies Inc.
3761 Victoria Park Ave., Scarborough,
Ontario, Canada M1W 3S2
Telex: 06-966640 (ATI TOR) Tel.: (416) 756-0718
Fax: (416) 756-0720

Trademarks: ATI, VGA WONDER, EGA WONDER - ATI Technologies Inc.; Multisync - NEC Home Electronics Inc.; AUTOCAD - Autodesk Inc.; WINDOWS - Microsoft Inc.; GEM - Digital Research Inc.; VENTURA - Xerox Corp.; AUTOSHARE - Autodesk Inc.; IBM, VGA, EGA, CGA - International Business Machines Corp.

BOOK REVIEWS

Programmer's Introduction to the Macintosh Family

Apple Computer, Inc.

Addison-Wesley, Reading, MA: 1988, 197 pages, \$26.95.

Reviewed by Dong H. Kim

By now, everyone in the Macintosh programming community knows what it's like to wade through the five volumes of *Inside Macintosh*. The mind-numbing effect of thousands of pages in such official documents must have turned away many would-be programmers.

An American philosopher I knew once said that trying to read *Being and Time* by Martin Heidegger, a renowned German philosopher, is somewhat akin to trying to swim in sand. Wading through most technical computer manuals is at least that bad—perhaps closer to swimming in mud. Since official documents tend to present all information as being of equal importance, little room is left for providing an insightful perspective on a computing system or programming environment as a whole. Consequently, there is an inevitable information "overload."

I wish I'd had *Programmer's Introduction to the Macintosh Family* in my hands a couple of years ago. Certainly, my encounter with *Inside Macintosh* would have been easier and more immediately productive. A very concise introduction to the basic theories and technical operations undergirding the Macintosh computer, loaded with numerous insightful programming suggestions, this book would have saved me a lot of head-scratching and page-



flipping through these earlier volumes. In short, this book greatly deepens the reader's knowledge of the Macintosh programming framework by providing an illuminating background that makes Apple's previous documentation comprehensible and eas-

ier to understand.

Written by an anonymous team of Apple programmers, this Macintosh family portrait is divided into nine well-organized chapters and three indexes. The first index takes up important issues of compatibility across Macintosh

computers and gives us the latest "official" guidelines for ensuring compatibility with future systems. The second index presents the most frequently used Toolbox routines in an easy-to-find format. The information on APDA (Apple Programmer's and Developer's Association) is given in the third index.

The first chapter, "An Overview of the Macintosh," provides the answers to the question, "Why program for the Macintosh?" Here you'll find clear explanations of the key programming ideas that made the Macintosh such a revolutionary computer. A brief discussion of "event-driven" programming is also provided.

The second chapter, "The Software Anatomy of the Macintosh," deals with such vital topics as Resources, QuickDraw, Toolbox, and the Finder. After a good discussion of the hierarchical nature of Toolbox routines, we are advised: "Working around the Toolbox routines to write your own codes takes more code and more energy and introduces bugs. Because the Toolbox routines are largely in ROM and are highly optimized, you will not find yourself gaining any real execution speed. And the potential incompatibility problems you create for yourself are just not worth the effort." This is why, we are told, it's better to use the Toolbox rather than design our own ways to handle such things as menus, windows, and dialog boxes, even though it is perfectly possible to do so.

Many programmers forget to focus on the user interface design until all their routines are finalized. Then they try to glue everything together with interface design. This approach guarantees frustration

continued

ALSO REVIEWED

The C Programming Language, 2nd ed.

Advanced C Tips and Techniques

Introduction to Object-Oriented Programs and Smalltalk

What Every Engineer Should Know About Artificial Intelligence

Principles of Database Systems

Compact Disk Products, Inc.

CD-ROM/WORM

ALL PRODUCTS, LOWEST PRICES, EXPERT ADVICE

INTRODUCTORY OFFERS

Hitachi 1503S or 3500S CD-ROM Drive with your choice of:	
- McGraw Hill Science and Technical Reference Set	\$895
- Grolier Electronic Encyclopedia	\$995
- Microsoft Bookshelf	\$895
- PG&G Library (Disks 1 - 1000)	\$895

CD-ROM SOFTWARE

Oxford English Dictionary	NEW	\$945
Comstock Stock Photography On CD	NEW	\$445
Educomp Public Domain/Shareware for the Mac	NEW	\$169
The New Grolier Electronic Encyclopedia		\$359
McGraw Hill or Bookshelf or PG&G		\$269
The Bible Library		\$495
Kirk-Othmer Encyclopedia of Chemical Technology		\$945
Registry of Mass Spectral Data		\$2655
Geovision U.S. Atlas and Mapmaker		\$795

TOLL FREE ORDER LINE • 800-MEGABYTE (634-2298)

CD-ROM and WORM DRIVES

Hitachi 1503S External CD-ROM Drive with Audio	\$729
1503S with Digital Audio Output	\$1229
Hitachi 3500S Internal 1/2 Height CD-ROM Drive w/Audio	\$719
Maxtor 800 MB WORM Drive	\$3799
Dptotech Laserbank 400 MB WORM Drive	\$2799
Portable 286 with CD-ROM Drive	\$795

CD-Play (\$89) Pop-up utility that permits user to play all audio CDs on Hitachi and compatible drives. Output to headphones or amplifier.

CD-PlaySampler (\$149) Same features as CD-Play plus the ability to name two points on an audio CD and loop between them.

CD-AudioFile (\$149) Automatically creates database records of all your audio CDs. Allows you to store a preferred play sequence for each disk. Automatic recognition of CDs. Creates DBase compatible records.

CDP

Compact Disk Products
223 E. 85th St.
New York, NY 10029
Tel. 212-737-8400
Fax 212-439-9109
CompuServe 75530214

Free 3 Month
Subscription to
CD-ROM Review
with orders over
\$300

INTERNATIONAL ORDERS A SPECIALTY

Australian Agent: KEWTEL
145 Cotham Rd.
Kew, Victoria 3101
Tel. (03) 817-5933

Industrial Control Systems
Intelligent Terminals
Diskless Systems

ROMDISK™

For the IBM
PC, XT, AT, PS/2
and PC DOS* or MS DOS*

Disk & Disk Drive Emulators/New Models & Prices

- Emulates a diskette or hard disk, adapter and disk drive—SSDD (180K), DSDD (360K), HC (786K or 1.2MB) 720K or 1.44MB.
- Standard and Cassette models for both EPROM and SRAM technology. Interchangeable EPROM and SRAM cassettes.
- Two Autoboot, File and EPROM programming modes.
- Simply copy a Master Diskette to program the EPROMs.
- Operation on a DMA channel or programmed I/O.
- 1/2 high disk drive escutcheon for front loading cassettes.
- List prices with memory ICs from \$295 to \$1095. Models available OEM without EPROMs.

EPROM MODELS programmable and read only

SRAM MODELS read and write—battery backed

FLASH EPROM MODELS electrically erasable and reprogrammable



CURTIS, INC.
2837 North Fairview Ave. • St. Paul, MN 55113
612/631-9512 Fax 612/631-9508



* IBM PC, XT, AT and PC DOS are trademarks of IBM, MS DOS is a trademark of Microsoft

BOOK REVIEWS

and possible failure with the Macintosh, because the programs are driven by user events and the user interface is the most important part of the program. It is essential that you understand how you expect the user to interact with your program before you start coding. This timely advice is typical of the chapter.

The third chapter, "An Eventful Experience," gives a delightful account of the idea behind the main event loop, what must be in it, and how its requirements relate to application programs. It also discusses topics such as the event queue, event-masking, and ways of handling Activate, Mouse, Key, Disk-insert, and Update events.

Next, the authors move on to the very important subject of memory management on the Macintosh. They explain how and when objects stored in memory are subject to being relocated, how to know when they can be moved around, and how to keep track of such moves at all times. Insightful comments on pointers, handles, blocks, the stack, heaps, and memory fragmentation are scattered throughout this fourth chapter. For example, we learn that UnloadSeg does not, as its name implies it does, actually unload the segment, but that it unlocks the segment, permitting the Memory Manager to purge it or re-allocate the space it occupies if necessary. Three primary causes of out-of-memory conditions are also discussed: overzealous use of nonrelocatable blocks, the use of desk accessories, and the system's own use of memory.

The key to Macintosh programming is learning how to call the correct routines provided for you in the ROM and operating system. Chapter 5 covers those routines related to QuickDraw and Color QuickDraw. Here we are told why everything is in graphics in the Macintosh. Bits and pixels as well as graphics ports are explained in detail. The section on Color QuickDraw is

particularly interesting and useful, since this is still a relatively new subject.

The sixth chapter goes into a detailed account of the User Interface Toolbox and deals with the Window, Menu, Dialog, Control Managers, and TextEdit.

Regions of a window and the contents of a window record are masterfully explained in just three pages of chapter 6. Have you ever wondered how NewWindow and GetNewWindow are different? Here you'll find out. (NewWindow creates windows dynamically, while GetNewWindow loads a predefined window resource from the appropriate resource file and carries out the same function as NewWindow. Thus, NewWindow requires eight arguments, whereas GetNewWindow requires only three.) Other similarly helpful explanations and distinctions are scattered throughout this important chapter, regarding the Menu, Dialog, and Control managers.

Chapter 7 deals with file management: how files are organized, how we access them, and how our programs create, open, read, write, and close disk files. Such concepts as file types and creators are clearly discussed. A good example of file handling is given at the end of the chapter.

Chapter 8 gives a brief account of development tools in the form of HyperCard, the Macintosh Programmer's Workshop, and MacAPP. Object-oriented programming is also briefly touched upon here. The next chapter, "Becoming a Macintosh Developer," explains what to expect in *Inside Macintosh* and how to find your way around these volumes. The chapter also gives information on the procedure to follow to become a registered Macintosh developer.

If I have one complaint to make about this useful book, it is that Apple should have published it 2 or 3 years ago—but

continued



OUR μ P DEVELOPMENT TOOLS HELP PROJECTS GET ON THEIR FEET.

The "creature" shown above doesn't depict a futuristic lunar landing. Rather, it represents a *polar* landing of a sophisticated weather monitoring device. A new parachute-deployed device that instantly transmits vital environmental data to waiting scientists. And whose Antarctic installation and erection now happen automatically, in a matter of minutes, allowing critical data collection in remote areas that were impossible to reach before.

This "Self-Erecting Weather Station," sponsored by the National Science Foundation and designed and developed by Polar Research Lab, was made possible by Avocet and AVSIM™, Avocet's unparalleled simulator/debugger.



The AVSIM Full-Screen Display

Unequaled capability

Polar Research needed AVSIM's sophistication to control the sensors in the weather station's "legs" and to create its transmitter. AVSIM's detailed on-screen CPU simulation, unlimited breakpoint facility, and unique "undo" capability gave their engineers the ease of use and flexibility that allowed them to *execute and test the software even before the hardware was ready*. Saving crucial time and frustration in both the programming and testing phases of development. And money, too: at only \$379, AVSIM is a fraction of the cost of additional hardware.

Complete compatibility: from the ground up

Best of all, AVSIM is completely compatible with our AVMAC™ macro assemblers and our AVOCET C™ cross compilers – the ideal combination of tools which gives you a comprehensive development solution.

Get your own project off the ground: try before you buy

Try the AVSIM demo yourself for 30 days. If you're not satisfied for any reason, return the unopened program disk for a full refund – less \$35 for the demo disk and manual, which are yours to keep.

Free Catalog



Call Toll-Free 1-800-448-8500*

For your free catalog, to order, or for more information about AVSIM and other Avocet products.

Call Avocet today and ask about our complete line of affordably priced software and hardware μ P development tools. Discover how we can help you get your next project on its feet, too.

AVOCET

SYSTEMS, INC.

©1988 Avocet Systems, Inc. All rights reserved.

THE SOURCE FOR QUALITY μ P DEVELOPMENT TOOLS

Quality Was Never Priced So Low!

2400 bps
2400 / 1200 / 300 bps
MODEM

ONLY

\$100

MADE IN U.S.A.

5 Year Parts and Labor Warranty

Our 2400HC² Hayes Compatible Half Card modem is for IBM PC/XT/AT and compatible computers. It uses the standard 'AT' command set. Included with our modem we supply communications software, a 7 foot cord and documentation.

We build our modems at a mil-spec board house located in suburban Chicago, using quality components. We test every modem shipped and back our confidence in our quality with a 5 year parts and labor warranty from the factory and a 30 day money back guarantee.

Kiss

 Engineering Inc.

162 N. Franklin St. • 5th Floor • Chicago, IL 60606
Toll Free Order Line for orders only 1-800-442-2285
For orders in Illinois 1-312-358-1501
Kiss Engineering Technical Support 1-800-442-2285

Orders within the USA (including Alaska & Hawaii) are shipped FREE via UPS.

Payment in U.S. funds drawn on a U.S. bank required.
COD orders placed before 2 pm CST shipped same day.

Illinois residents add 8% sales tax.
We do not accept credit cards.
Please send check or money order for \$100.

IBM PC® COMPATIBLE SINGLE BOARD COMPUTER

Quark/PC®+

4" x 6"



From
\$325.
quantity one

COMDEX/Fall '88

- Low Power — Less than 3 Watts No. H7029
- Optional on-board Video LCD Driver See our full product line
- Ideal for any PC compatible OEM product which is not a personal computer

Includes: 1. Powerful V40® CPU (Faster than a PC) 2. Math Co-Processor Socket 3. 5 Volt Only Operation (3 watts) 4. Speaker Port 5. Keyboard Port 6. Parallel Printer Port 7. PC Bus 8. PC Compatible BIOS ROM 9. 1 Serial Port

On board Options include: 1. 5 Mode Video Controller Option (Monochrome, Hercules® Graphics, CGA, High Res CGA, LCD Driver) 2. Floppy Disk Controller (3.5"/5.25", 360K/720K/1.2 MB) 3. SCSI Bus Interface (Hard Disk etc.) 4. Up to 768K RAM 5. Battery-Backed-up Real-Time-Clock 6. 2 Additional RS232C Serial Ports

To order or enquire call us today.
Megatel Computer Corporation
(416) 745-7214 FAX (416) 745-8792

174 Turbine Drive, Weston, Ontario M9L 2S2
U.S. Address: 1051 Clinton St., Buffalo, N.Y. 14206

Distributors:

Germany: V&C Computers (06071) 25666 FAX (06071) 5863
Italy and Southern Europe:
NCS Italia (0331) 256-524 FAX (0331) 256-018
U.K.: Densitron (0959) 76331 FAX (0959) 71017
Australia: Asp Microcomputers (02) 500-0628 FAX (02) 500-9461
Quark is a registered trademark of F&K Manufacturing Company. Hercules is a registered trademark of Hercules Corporation. V40 is a registered trademark of NEC Corp. IBM PC is a registered trademark of IBM Corporation.

megatel

better late than never. On the other hand, some readers may argue that the authors should have devoted more space to newer topics, such as Color QuickDraw and MultiFinder. Otherwise, this book provides a solid foundation for understanding the Macintosh family of computers. Throughout the book, and especially in chapters 4, 5, and 6, I found valuable nuggets that clarified the nature of code and operations I had read about elsewhere but had failed to understand.

In addition to being well-organized and informative, the book is enjoyable to read. It is written in a relaxed style; they also make appropriate and frequent use of diagrams and tables to illustrate concepts under discussion; they also follow up with fully coded examples. One example: "A Macintosh program is not, as some people have said, an amusement park ride with moving stairs you can't predict. It's more like an escalator whose stairs take you where you want to go, quickly and effortlessly. Just don't try to drive the escalator." Another example: "An event-driven environment is one in which the user gets to say to the programmer, OK, I have your program now. Don't call me, I'll call you."

In the final analysis, this is an indispensable first book for anyone who wants to program computers in the Macintosh family. It is also the long-awaited definitive introduction for those who haven't been exposed to the Macintosh philosophy of programming—a chance to find out at last what makes people so evangelical about the Mac.

BRIEFLY NOTED

The C Programming Language, 2nd ed. by Brian W. Kernighan and Dennis M. Ritchie, Prentice-Hall, Englewood Cliffs, NJ: 1988, 272 pages, \$28. This new edition of *The C Programming Language* is a complete rewrite

commemorating the tenth anniversary of the original best-seller that introduced the language. It follows the outline of the original book, but Kernighan and Ritchie have updated it to reflect the draft ANSI standard for C. The book incorporates all the so-called post-K&R extensions, including enumerations and function prototypes.

The new book talks about C in comparison to Pascal instead of PL/1. The typography is vastly improved, and the sections on declaration type precedence and separate compilation are more detailed and comprehensive than they were in the original.

Written in a terse and cryptic style faithful to the spirit of C, the new K&R will please fans of the old. The book remains an introduction to the language for experienced programmers; even with the new material, it is neither a beginner's tutorial nor a comprehensive reference.—Joel West

Advanced C Tips and Techniques by Paul Anderson and Gail Anderson, Howard W. Sams, Indianapolis, IN: 1988, 464 pages, \$24.95. *Advanced C Tips and Techniques* starts off easy with a refresher chapter, then pops the latch and opens the hood to expose the mechanics of the C language. Here you'll get an inside look at the text area (where program code lives), the data area (for static and global variables), the stack (which manages procedure calls and local variables), and the heap (the realm of run-time storage created by alloc()).

It's nice to see good explanations of why C does some of the things it does. If you're a black-belt samurai C programmer, you may find some of the topics trivial, but it still makes interesting reading. For example, the authors point out that one reason C does not initialize automatic variables at run time is because problems would arise if a goto transferred control inside a

continued

Because Resources Should Be Shared



BayTech engineers Printer Sharing.

Make the most of your investments in valuable printers, computers, plotters, modems, and other resources with a printer-sharing device from BayTech. We manufacture a diverse product line engineered for flexibility and speed that lets you share your resources and maximize your investments.

From simply sharing one or more printers between computers, to creating a complete network for printer sharing and computer-to-computer communication, BayTech has a device designed to meet your specifications.

Call toll free today to learn more about maximizing your resources.

Circle 43 on Reader Service Card

BayTech



*Bay Technical Associates, Inc.,
Data Communications Products Division
200 North Second St., P.O. Box 387,
Bay Saint Louis, MS 39520 USA
Telex: 910-333-1618 BAYTECH.
Telephone: 601-467-8231 or toll-free
800-523-2702, EXT 981*

DAZZLING PERFORMANCE.



'286/55

COMPLETE 12MHz '286 WITH 32MB HARD DRIVE ONLY \$1295.00

- 80286 CPU, 8/12.5 MHz Dual Speed, Keyboard Selectable.
- Zero-Wait State RAM, 512K expandable to 4MB on the motherboard (16MB System Total).
- 32MB Hard Drive, 1.2MB Floppy Drive.
- Ultra high speed Hard/Floppy controller. 1:1 interleave, 800 KB/sec transfer rate.
- High Res 12" Amber Display with Tilt and Swivel Base. Compatible graphics controller.
- ZEOS Enhanced Keyboard, Pleasant Tactile/Click Feel.
- Serial and Parallel Printer Ports.
- Clock/Calendar with Battery Backup.
- 6-16 and 2-8 bit expansion slots.
- 80287 support, up to 12 MHz.
- Space Saver Case with Security Lock, LED indicators.

12MHz, 16MHz and 20MHz '286 HARD DRIVE SYSTEMS

As high as 20MHz! Dazzling performance is yours with one of these high performance full size ZEOS '286 Systems

Each comes complete with our standard features including drives, monitor, high speed controller, etc. Our full size case features room for up to 5 half-high drives, two of which are internal. Incredible values.

■ **286/12**—Complete 12.5MHz System with 512K of Zero-Wait RAM, High Speed 32MB, 33ms Hard Drive and all the standard ZEOS goodies. **ONLY \$1395.00**

■ **286/16**—Complete 16MHz system with 1MB RAM on board and High Speed 32MB Hard Drive. *Faster than a '386 16MHz when running 16-bit software!*

ONLY \$1895.00

■ **286/20**—At 20MHz, it's the fastest. Complete with our 32 MB, 33ms Hard Drive and 1MB RAM. This is what Dazzling Speed is all about. **ONLY \$2095.00**



'286/F

DAZZLING PERFORMANCE. INCREDIBLE PRICES.

Can you believe it? *Yes, you can!*

We've proven it to thousands and we would like to prove it to you. ZEOS® systems are sold *complete*, ready to plug in and fly right out of the box. And the quality

and prices are incredible.

How is it possible? Because your ZEOS computer comes to you *factory direct*, fully assembled, burned-in and tested in our own laboratories. Every system is built to order. Custom built actually, right to your own specifications.

And our quality and performance are second to none.

We don't just say it. We guarantee it. That's why your new ZEOS system comes with a Full One Year Limited Warranty and our 30 day Full Refund Satisfaction Guarantee.

So pick out your dream

INCREDIBLE PRICES.



'386/DT

**COMPLETE 16MHz '386 DESKTOP
WITH 32MB HARD DRIVE.**

ONLY \$2495.00
(20MHz add \$500)

- Genuine 32-bit Intel 80386, 16 or 20MHz parts.
- 1MB of RAM Expandable to 16MB.
- 32MB, 33ms Hard Drive, 1.2MB floppy drive.
- Ultra high speed Hard/Floppy controller. 1:1 interleave, 800 KB/sec transfer rate!
- High Res 12" Amber Display with Tilt and Swivel Base. Compatible graphics controller.
- 101 Key ZEOS Tactile Click keyboard.
- Serial and Parallel/Printer Ports.
- Clock/Calendar with Battery Backup.
- 2-32, 4-16 and 2-8 bit slots.
- 80287 and 80387 support.

**COMPLETE '386 VERTICAL SYSTEM.
64MB DRIVE!**

ONLY \$2995.00
(20MHz add \$500)

Acknowledged worldwide as the highest performance value anywhere. Same great standard ZEOS features found on our other complete systems plus:

- 64KB Zero-Wait CACHE using 64K of SRAM.
- 1MB of 32-bit RAM system expandable up to 16MB.
- 64MB Seagate Hard Drive.
- 80287 and 80387 optional.
- Heavy Duty Vertical Case.

Ask about our 25MHz systems too!



'386/V

machine and order it now with confidence. Dazzling performance and incredible prices await you. *Guaranteed.* Order now by calling 800-423-5891.

Other ZEOS Options Include:

■ Basic Configurations:
Call for prices on systems

without drives, etc.

■ EGA/VGA Upgrades.
14" EGA color monitor with EGA card, add \$495.
14" VGA system, add only \$695

■ High Capacity Drives.
Many other drives and options are available. Call Toll Free for details, 800-423-5891

**ORDER NOW TOLL FREE
800-423-5891**

FAX Orders Dial: 612-633-2310
In Minnesota Call: 612-633-4591
530 5th Ave. NW, St. Paul, MN 55112
Open days, evenings and weekends.

MasterCard, VISA and C.O.D.
Se habla Español.



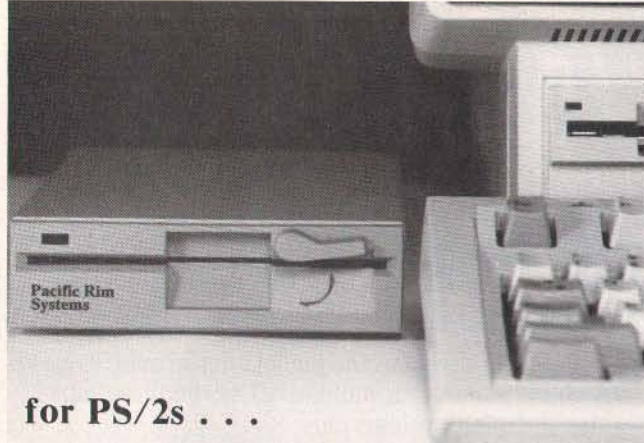

for PS/2s . . .



for laptops . . .

End 3 1/2 Inch Frustration

Complete solutions for using 5 1/4" diskettes on your 3 1/2" based computer.

Our solutions for IBM® PS/2® computers are available in either 1.2MB or 360KB varieties, ending frustrations for all media standards. Both are **complete** with everything needed for any model PS/2 in a single box. No power supply, no adapter board, and we don't waste an expansion slot.

Our laptop solutions also offer "one-drive-fits-all" convenience. Simply order the cable for the computer of your choice. All popular laptops are supported.

Customized versions available for special applications. Domestic and international resellers welcome.

5 1/4" Subsystem Specialists

Pacific Rim Systems, Inc.

2570 Barrington Court
Hayward, California 94545
FAX: (415) 782-1017
Telephone: (415) 782-1013

block that contained automatic variables.

The authors explain how the C constructs operate from the point of view of the underlying system architecture. And you will find lots of source code that encourages exploration of C's internal structure.

Next comes a good guide through the confusing—even to experienced programmers—maze of arrays and pointers, though this is not so much a set of hard-and-fast rules describing proper techniques as it is a series of invitations to experiment. Some of the examples given are surprising; you'll find yourself looking at an expression with a different eye.

The section covering debugging presents an assortment of techniques, most of them basic commonsense methods. The author offers some novel suggestions for applying front-end code to the memory allocation functions (use of which is notorious for yielding cranky code); the result is a tightening up of error checking in these routines.

The appendixes of *Advanced C Tips and Techniques* really shine. Here you'll find useful minimanuals for popular C compilers, including SCO Xenix System V, Microsoft C 5.0, Turbo C, Microsoft's System V Unix (for the AT and 80386 machines), and, of course, the standard Unix C compiler.

If you're a serious C programmer and your work spans a variety of machines, this book belongs on your shelf right next to the high-potency vitamins.—*Richard Grehan*

An Introduction to Object-Oriented Programming and Smalltalk by Lewis J. Pinson and Richard S. Wiener, Addison-Wesley, Reading, MA: 1988, 502 pages, \$27.95. Object-oriented programs have been around since the development of Smalltalk at the Xerox Palo Alto Research Center labs in the late 1970s, but only recently have hardware prices fallen enough to make such

systems obtainable by home enthusiasts and useful to small businesses. In the 1980s, the invention of C++, an extension of the C language that includes constructs for object-oriented programming, has greatly increased interest in the object-oriented programming methodology.

With uncanny timing, Lewis J. Pinson and Richard S. Wiener, professors at the University of Colorado, have written two books to teach this methodology, using the two most prominent object-oriented languages, C++ and Smalltalk.

C++ is a superset of C that retains all the power of that language but includes object-oriented features, such as data abstraction, encapsulation, inheritance, and polymorphism. Invented at Bell Labs by Bjarne Stroustrup, the original C++ is a preprocessor that interprets C++ code and translates it into C so that compatibility with existing C compilers is guaranteed. Thus, the programmer is spared efficiency problems that often plague Smalltalk environments.

Pinson and Wiener's book assumes that the reader understands C but knows nothing about C++ or object-oriented programming. The book provides a tutorial of C++ and then continues into a more technical presentation of the topics listed above (e.g., data abstraction). The programming examples are particularly enlightening, such as the "superfast spelling checker" that effectively uses data encapsulation and inheritance. The book concludes with case studies, including the grand finale, an interactive algebraic expression evaluator.

The authors consider Smalltalk the language "most true to the object-oriented philosophy." Therefore, they devote almost twice as many pages to Smalltalk in order to delve into the methodology, the language, and the Smalltalk environment. For the

continued

STATE OF THE A T.



ZENITH UNVEILS THE AT[®]-COMPATIBLE COLLECTION.

ZENITH INNOVATES AGAIN—Zenith's collection of AT compatibles began with the Z-386™. An introduction that ushered in such industry firsts as zero wait states, cache memory and slushware—for greater speed and faster memory access. Once again, Zenith's constant pursuit of innovative, user-relevant technology has created faster, better computers.

The new Z-248/12™ and Z-286 LP™ desktop PCs. Two new master-strokes that respond to today's need for smaller size and maximum expansion. Two more reasons why Zenith is the leading supplier of AT-compatible systems.

The compact Z-286 LP combines a four-inch low profile and space saving small footprint with performance you'd expect from a unit three times its size.

The Z-286 LP comes standard with 1MB RAM—expandable to 6MB without using an expansion slot. Generous memory capacity to run new MS OS/2™ applications. And with a single 3.5" floppy and fast 40MB hard disk you have truly impressive storage capacity.

The Z-248/12 is among the fastest 286 systems available. Its zero wait state design magnifies its 12MHz to speed past 16MHz systems with wait states.

The Z-248 is also standard with 1MB RAM and is expandable up to 6MB without using an expansion slot. However, four open expansion slots can artfully handle future growth. Configurations of 5.25", 3.5" floppy or 40, 80 and 160MB hard disks truly expand all your options.

All systems are available with Zenith's revolutionary Flat Technology Monitor (shown above) and VGA-compatible video card for ultimate video performance.

With breakthrough after breakthrough, these new computers are yet further proof that Zenith's AT-compatibles define the State of the Art. See the "AT Collection" now showing at your Zenith Data Systems authorized dealer. For your nearest location call: 1-800-553-0350.

ZENITH

**data
systems**

THE QUALITY GOES IN BEFORE THE NAME GOES ON[®]

[®] AT is a registered trademark of IBM Corp.

[™] MS OS/2 is a trademark of Microsoft Corp.

© 1988, Zenith Data Systems

QSET:

The Simple Approach to Powerful Solutions.

And simple means *fast!* Applications in use instead of in development. Applications *completed* when other system developers are still getting started.

QSET is the most productive approach you can take to I/O applications. Easy to learn, fast, and flexible. Combines the power of UNIX, Xenix, C, and any 3GL you choose for powerful, portable applications. Supports relational, hierarchical, and network database structures.

Built-in program logic insures data and system integrity: you can't build a bad application using QSET.

Find out more. Call 800-727-2072. Ask for our product brochure and our very attractive introductory pricing offer.

QSET An Applications Software Solution.

QSET is a trademark of Business Management Data, Inc.
UNIX is a trademark of AT&T. Xenix is a trademark of Microsoft Corporation.
AT is a trademark of International Business Machines Corporation.

Menu driven

No new language

AT type environment

Rapid prototyping

Multi-user

Data and system integrity

most part, their Smalltalk book uses the perspective of this environment so that access to a Smalltalk machine is almost a necessity for using the book (screen diagrams are included, however). Given that Smalltalk environments are relatively rare and normally require a mouse, this is a small drawback to the book.

The authors present the central concepts of Smalltalk—but not the entire language—thoroughly, allowing you to explore further possibilities independently. In addition, topics are presented incrementally: on an elementary level at first, and later at a more advanced, abstract level. This eases the comprehension process considerably. Programs are generally small, well-chosen, and easy to understand and extend.

The book is designed as an introduction both to Smalltalk and to object-oriented programming. It assumes no prior knowledge of either. The discussion is squarely aimed at the professional programmer or advanced computer science student.—*Jason Levitt*

What Every Engineer Should Know About Artificial Intelligence by *William A. Taylor*, MIT Press, Cambridge, MA: 1988, 331 pages, \$25. Computers already can check circuit design rules and verify the manufacturability of printed circuit boards. They can calculate part routing in machine shops and devise the best assembly procedures in many factories. In short, AI is having a profound impact on every aspect of engineering.

The book offers an insightful survey of AI and expert systems for the engineering community. The author discusses multitudes of engineering opportunities in AI research and throws light on programming approaches such as function-based, object-oriented, and rule-based orientations. He also introduces the important AI languages, Lisp and Prolog.

Taylor is an international

consultant on practical applications of AI, and his experience shows in the book's hands-on details. The book concludes with a look at future trends and a fascinating discussion of the Japanese computer industry and the fifth-generation computer project.

—*Dong H. Kim*

Principles of Database Systems by *Jeffrey D. Ullman*, Computer Science Press, Rockville, MD: 1988, 631 pages, \$41.95. This new volume covers mainly "classical" (relational) database systems. Knowledge-based systems, as represented by logical rules, are also introduced. After defining key terms for relational, object, and knowledge-based systems, the author shows how these methodologies are inter-related in the development of more powerful systems. Examples of programming languages used in each methodology, such as DDL (Data Definition Language), proposed by the Data Base Task Group, and the object-oriented language OPAL, are explained and discussed extensively.

The book also deals with physical storage techniques, design theories for databases, security, integrity, concurrency control, recovery in database systems, and distributed database systems. The chapter entitled "Protecting the Database Against Misuse" contains particularly valuable discussions of computer security and safety. The book includes over 200 exercises at graded levels of difficulty.

—*Dong H. Kim*

CONTRIBUTORS

Dong H. Kim is a researcher and consultant in artificial intelligence. He lives in Chapel Hill, North Carolina. **Joel West** is president of Palomar Software and lives in Vista, California. **Richard Grehan** is a senior technical editor at BYTE. **Jason Levitt** is a Unix consultant in Austin, Texas.

FREE Line Conditioner in every UPS.

UPS-250
250 WATTS
MAX. OUTPUT



SENDON
Affordable Power Protection

DEALERS
& DISTRIBUTORS
WELCOME
TEL: 416-470-6611
FAX: 416-479-7392



UPS-400
400 WATTS
MAX. OUTPUT

Now, at no extra charge, the new Sendon UPS back-up power supplies feature a built-in line conditioner that enables your computer to work indefinitely under brown-out conditions without drawing on the battery power reserve, which is saved for emergency uses (black-outs).

FOR MORE INFORMATION, PLEASE CONTACT:

N.J. Instruments & Equipment TEL: 201-729-4293 FAX: 201-729-5569	N.Y. C.P.G. 800-431-9008 716-343-9912	B.C. Sonnet Systems 604-276-2599 604-276-0672	Quebec Jasmine Technology 514-871-2233 514-871-0616
--	--	---	---

COMDEX/Fall See us at the Fall Comdex Show in the Las Vegas Bally

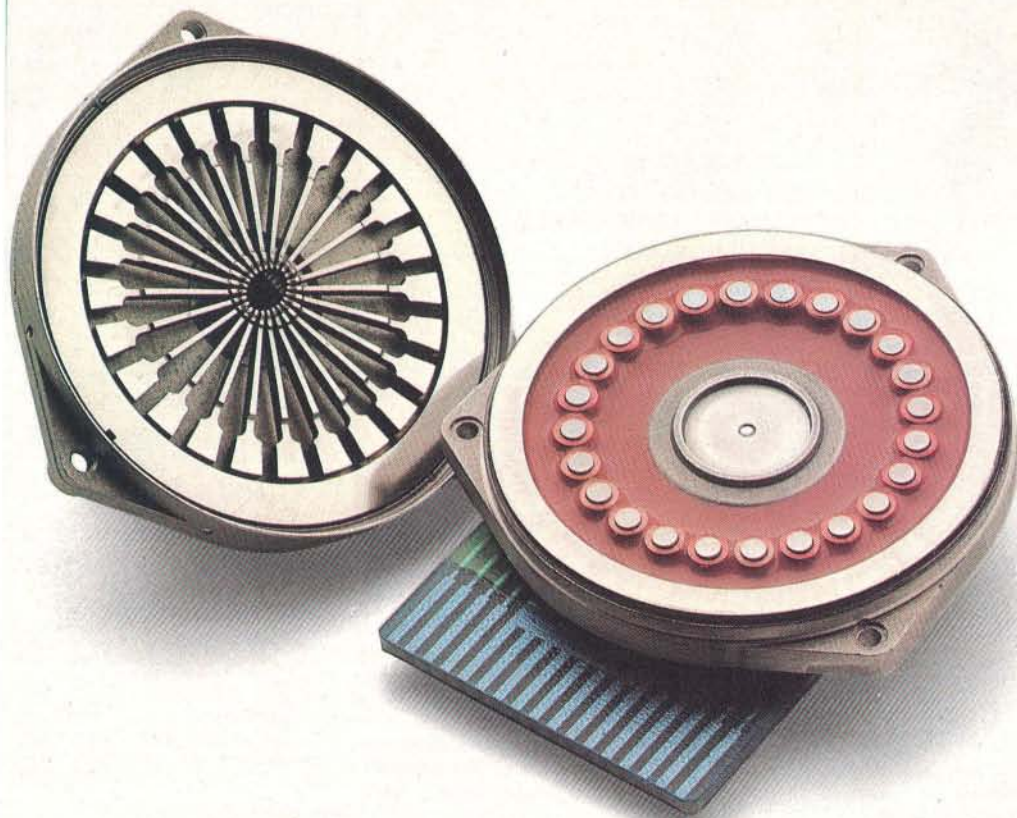

HEADS UP, JAPAN.

Above you see the most ingenious printhead developed in years.

It's a new stored-energy head that uses less energy and delivers more speed than traditional ballistic printheads.

And according to *Infoworld**, delivers constantly superior print quality, with letter quality comparable to a laser.

You'll find this printhead, with its seven patents on design, materials, and production process, only on Mannesmann Tally's newest family of printers. Including the 24-needle MT330 word processing printer, a 10,000 page-per-month, 300 cps printer. And

the 18-needle MT340 data processing and industrial graphics printer, a 13,000 page-per-month, 400 cps machine.

We invite you to compare either of these heavy-duty printers to their Japanese counterparts.

Because head to head, we win.

And body to body? Again from *Infoworld*: "...most plastic and metal components appear quite a bit sturdier than their Japanese equivalents."

Again, bad news for Japan. But very good news for you.

To take advantage of this news at a pleasantly surprising

price, call the number below for the name of your nearest dealer.



MT340

MT330 with optional dual bin sheet feeder

MANNESMANN
TALLY

800-843-1347 Ext. 170

In Washington state, call:
206-251-5524 Ext. 170

**Infoworld*, July 6, 1987

PRICES YOU CAN FIND ONLY IN

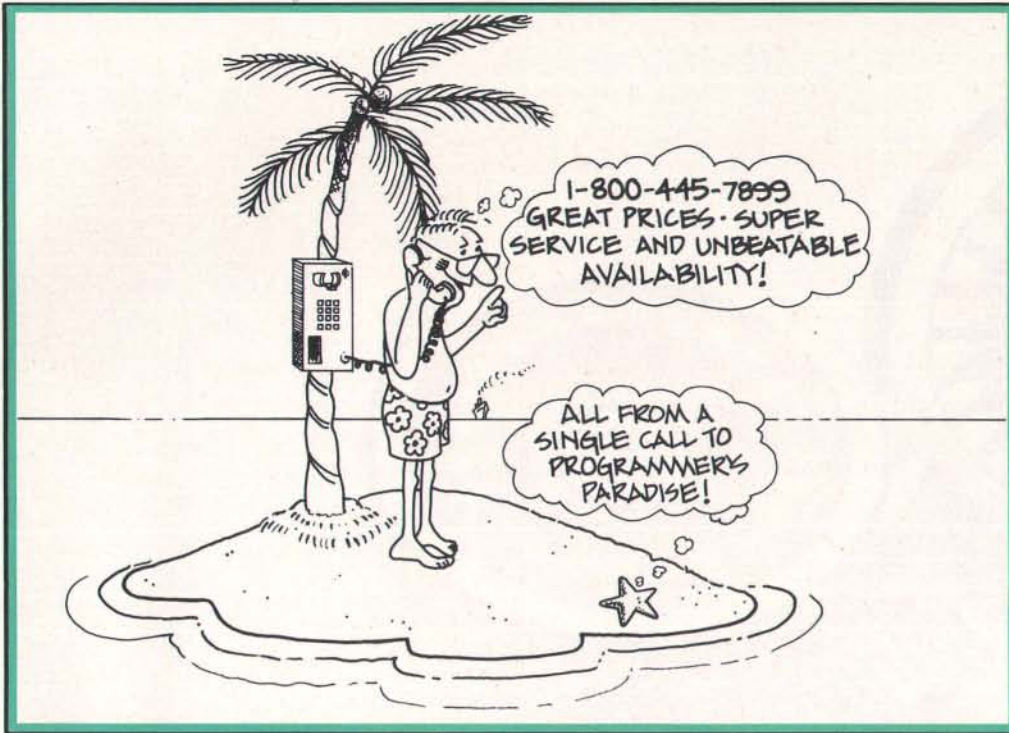

CALL PROGRAMMER'S PARADISE TODAY and discover our commitment to bringing you the best software at the best prices. You'll also find software pros to help you select the product that you need plus immediate shipment on our stock of 1000 products and a 30-day money back guarantee. Paradise is ready and waiting for you.

	LIST OURS
ASSEMBLY LANGUAGE	
Advantage Disassembler	295 279
MS Macro Assembler	150 105
OPTASM	129 115
Visible Computer: 80286	100 90
BASIC	
GraphPak Professional	149 129
LaserPak	69 60
MS BASIC/6.0	295 199
MS QuickBASIC	99 69
QBase	99 90
QBase Report	69 60
QuickMenu	49 45
QuickPak Professional	149 129
QuickWindows	79 70
w/Source	99 90
Turbo Basic	100 69
Turbo Basic Toolboxes	100 69
C LANGUAGE	
ADVANTAGE C + +	495 479
C-terp	298 232
High C	595 529
Lattice C	450 289
Microsoft C	450 299
NDP C-386	595 529
QuickC	99 69
RUN/C Professional	250 159
Turbo C	150 105
WATCOM C	295 269
C LIBRARIES/UTILITIES	
C ASYNCH MANAGER	175 137
C TOOLS PLUS/5.0	129 101
C Utility Library	199 139
CxPERT	395 335
Essential Comm Library	185 125
Greenleaf Bus. MathLib.	239 159
Greenleaf Comm Library	225 169
Greenleaf Functions	209 155
Greenleaf SuperFunctions	265 179
Greenleaf TurboFunctions	109 79
PforCe	395 215
PC-lint	139 101
Pre-C	295 159
Resident C w/Source	198 169
TimeSlicer	295 279
w/Source	1000 899
Turbo C Tools	129 99

	LIST OURS
C GRAPHICS	
Essential Graphics	299 229
w/Source	598 509
GraphicC	395 322
GSS Graphic Dev. Toolkit	495 409
HALO '88	325 219
MetaWINDOW	195 162
MetaWINDOW/PLUS	275 232
C SCREENS/WINDOWS	
C-Scape	299 282
C-Worthy	295 249
JAM	750 684
PANEL Plus	495 395
PANEL/QC or TC	129 99
Vitamin C	225 162
VCScreen	100 80
Windows for C	195 169
Windows for Data	295 259
w/Source	590 519

	LIST OURS
MS FORTRAN	
286 DOS Merge	450 299
RM/FORTRAN	595 479
PASCAL COMPILERS	
Microsoft Pascal	300 199
Professional Pascal	595 549
Turbo Pascal	150 105
Turbo Pascal Dev. Toolkit	395 289

	LIST OURS
TURBO PASCAL ADD-ONS	
Overlay Manager	45 40
Science and Engin. Tools	75 70
T-Debug Plus V. 4.0	45 40
w/Source	90 80
Turbo Analyst 4.0	75 69
Turbo Geometry Library	150 135
Turbo Halo	95 80
Turbo MAGIC	199 179
Turbo Plus	100 89
Turbo POWER SCREEN	129 99
Turbo POWER TOOLS PLUS	129 99
Turbo Professional	99 80
Turbo Professional 4.0	99 80
Turbo Toolboxes (Borland)	100 69
Turbo Tutor	70 45
Turbo WINDOW/Pascal	95 80

	LIST OURS
DEBUGGERS	
Periscope I	695 563
Periscope II	175 141
Periscope II-X	145 106
Periscope III 10 MHZ	1395 1143
Pfix86plus	395 215
T-Debug PLUS V. 4.0	45 40
w/Source	90 80

	LIST OURS
DISK/DOS/KEYBOARD	
Advanced Norton Utilities	150 99
Command Plus V. 2.0	80 70
Disk Optimizer	70 59
Fastback Plus	189 142
Mace Utilities	99 90
Norton Commander	75 55
Norton Utilities	100 61
PC Tools Deluxe	80 70
Vfeature Deluxe	120 111
X-Tree Pro	129 111



	LIST OURS
dBASE LANGUAGE	
Clipper	695 439
dBFast	100 75
FoxBASE+	395 249
Flipper	195 182
R & R	149 129
SilverComm Library	150 139
Tom Rettig's Library	100 80
FORTRAN COMPILERS	
Lahey F77 FORTRAN	477 429
Lahey Personal FORTRAN	77 95 86

	LIST OURS
EDITORS	
BRIEF	195 CALL
Epsilon	195 151
KEDIT	150 120
MKS VI	75 66
Multi-Edit	99 90
Norton Editor	75 65
PC/EDT +	295 269
PI Editor	195 165
SPF/PC	245 185
VEDIT PLUS	185 131
FILE MANAGEMENT	
Btrieve	245 185
Xtrieve	245 189
Report Option	145 109
Btrieve/N	595 455
CBTREE	159 129



c-tree	395 318
r-tree	295 241
d-tree	495 395
DBC III	250 169
DBC III PLUS	750 599
dB.VISTA or dB.QUERY	195 CALL
Informix Products	CALL CALL
XQL	795 599

	LIST OURS
UNIX/XENIX	
Microport:	
286 DOS Merge	249 219
System V/AT (complete)	649 549
Runtime Package	249 209
Unlimited License Kit	249 209
SCO:	
XENIX Sys V (complete)	1295 999
Operating System	595 479
XENIX for PS/2 50,60,80	CALL CALL
OS/2 DEVELOPMENT TOOLS	
Btrieve for OS/2	595 455
Epsilon for OS/2	195 151
Greenleaf Bus MathLib	299 209
Greenleaf Data Windows	395 279
GSS Dev. Toolkit for OS/2	695 559

NEW RELEASES

ACTOR 1.2
Now supports 500K memory under LIM Expanded Memory Specifications, and adds full support for the new releases of Microsoft Windows/286 and Windows/386 (versions 2.1).
List: \$495 **Ours: \$423**

LATTICE C 3.3
Integrated environment that includes a screen editor and source level debugger. Lattice C 3.3 generates DOS, OS/2 or 'Family mode' programs which are compatible with either operating system.
List: \$450 **Ours: \$289**

Essential C Utility Library 4.0
New Power Functions include a fully functional editor, directory backup/maintenance utilities, mouse driven user interfaces, dialog boxes and much more.
List: \$199 **Ours: \$139**

PARADISE 1-800-445-7899

HOW WE WORK

PHONE ORDERS

Hours 9 AM - 7 PM EST. We accept MasterCard, Visa, American Express. Include \$3.95 per item for shipping and handling. All shipments by UPS ground. Rush service available, ask for rates when you order.

MAIL ORDERS

POs by mail or fax are welcome. Please include phone number.

RETURN POLICY

Our "No Hassle" policy means if you're not satisfied with a product from Programmer's, simply return it within 30 days for a refund. Some manufacturer's products cannot be returned once disk seals are broken, so check before you buy.

TECHNICAL
SUPPORT FROM
SOFTWARE
PROS



INTERNATIONAL SERVICE

Take advantage of our International business number for details on export charges and exchange rates. Payments should be made in U.S. dollars.

DEALERS AND CORPORATE ACCOUNTS

Call and ask for our catalog and special volume discounts.

UNBEATABLE PRICES

We'll match lower nationally advertised prices.

In NY: 914-332-4548

Customer Service:

914-332-0869

International Orders:

914-332-4548

Telex: 510-601-7602

Fax: 914-332-4021

Call or Write for
Latest Free Catalog!



PROGRAMMER'S PARADISE:

HALO '88

The latest version of the industry standard. Now adds to the library, subroutines and devices which facilitate the development of contemporary applications such as Desktop Publishing, Document Management, Vision, and Imaging. HALO '88's powerful functions reduce development time by offering fast, effective subroutines. And no other graphics library supports more languages, more compilers or more devices.

LIST: \$325

SPECIAL OFFER: \$219



HALO

POWER SCREEN

Powerful new screen management system for creating pop-up windows, pull-down menus, context sensitive help, and specially customized interfaces. Interactively paint screens using powerful editing functions and store the screen information in a database that can be maintained and accessed from your application programs. From Blaise Computing, a proven leader in providing useful tools for professional programmers.

LIST: \$129

OURS: \$99

BLAISE COMPUTING INC.



WENDIN-DOS VERSION 2.5

WENDIN-DOS is the new multi-tasking, multi-user MS-DOS replacement operating system for IBM compatible Personal Computers. Version 2.5 allows users to create hard disk partitions greater than 32 MB. WENDIN-DOS uses the MS-DOS file system, and supports MS-DOS commands while providing new ones to enable multi-tasking, file protection, and command language extensions and enables you to access your files with DOS, UNIX, or VAX/VMS style file names — whichever you prefer. WENDIN-DOS supports several users on the same computer. WENDIN-DOS now includes XTC, Wendin's ULTIMATE PROGRAMMER'S EDITOR!

Minimum 512K memory.
LIST: \$139 Ours: \$109

WENDIN

MICROSOFT COBOL COMPILER

The complete COBOL development solution for creating OS/2 and MS-DOS applications. It's certified high-level ANSI 85

COBOL. And it's a native code compiler, assuring extremely fast execution.

MICROSOFT COBOL supports the enormous memory requirements of mainframe applications. Develop and maintain applications on a personal computer and port them to a mini-computer or mainframe.

LIST: \$900 OURS: \$599



Microsoft®

	LIST OURS
KEDIT V.4.0 for OS/2	175 139
Microsoft Languages	CALL CALL
PANEL Plus for OS/2	495 395
Rbase for OS/2	895 CALL
Vitamin C for OS/2	345 279
Windows for Data for OS/2	395 CALL

OBJECT-ORIENTED PROGRAMMING

ACTOR	495 423
ADVANTAGE C++	495 479
C-talk	150 137
PforCe++	395 215
Smalltalk/V	100 85
Communications	50 45
EGA/VGA Color Ext.	50 45
Goodies #1 or 2	50 45
Smalltalk/V 286	200 169

386 SOFTWARE

386-to-the-Max	75 66
DESQview	130 115
FoxBASE+/386	595 399
High C 386	895 799
Microport	
System V/386 (complete)	899 769
Runtime System	299 255
MS Windows/386	195 130
NDP C or Fortran-386	595 529
PC-MOS 386	CALL CALL
Phar Lap 386/ASM/Link	495 409
SCO XENIX	
Sys. V 386 (complete)	1495 1195
Operating System	695 589
VM/386	245 182

ADDITIONAL PRODUCTS

Carbon Copy Plus	195 142
Dan Bricklin's Demo II	195 179
FLOW CHARTING II	229 205
Logitech MOD II Dev Sys	249 209
MathCAD	395 282
MKS Toolkit	169 145
PC Scheme	95 86
Pfinish	395 215
Plink86plus	495 275
PolyMake	149 131
PVCS Corporate	395 359
Source Print	97 80
Tree Diagrammer	77 70

BLAISE

ASYNCH MANAGER	175 137
C TOOLS PLUS/5.0	129 99
Turbo ASYNCH PLUS	129 99
Turbo C TOOLS	129 99
Turbo POWER SCREEN	129 99
Turbo POWER TOOLS PLUS	129 99

MICROSOFT

MS BASIC Compiler 6.0	295 199
MS C Compiler	450 299
MS COBOL Compiler	900 599
MS Excel	495 329
MS FORTRAN	450 299
MS Macro Assembler	150 99
MS Mouse Serial or Bus	150 99
w/EasyCAD	175 119
w/Windows	200 139
MS OS/2 Prog. Toolkit	350 239
MS Pascal Compiler	300 199
MS QuickBASIC	99 69
MS QuickC	99 69
w/serial mouse	249 149
MS Sort	195 130
MS Windows/286	99 69
MS Windows/386	195 130
MS Windows Dev. Kit	500 319
MS Word	450 285

MEDIA CYBERNETICS

Dr. HALO III	140 101
HALO DPE	195 162
HALO '88	325 219
HALO '88 - MS Developers	595 399
TurboHALO for C	95 80

WENDIN

Operating System Toolbox	99 80
PCNX	99 80
PCVMS	99 80
Wendin-DOS	139 109
Application Dev. Kit	99 80
XTC Text Editor	69 59

1-800-445-7899

Programmer's

Paradise™

A Division of Magellan Software Corp
55 South Broadway, Tarrytown, NY 10591

0 to 60 in 5 seconds



with new UniLab Microprocessor Development Tools

■ 64Kbytes from hard disk to emulation memory in 5 seconds. That's moving. But today you've got to be fast just to stay in the race for better microprocessor designs.

■ The secret is a new, high-speed parallel interface: the Orion bus. Which zips data between your PC/AT and the 8620 analyzer-emulator, breaking the RS-232 bottleneck.

■ The 8620 with O-bus gives you complete program diagnosis — and solutions — in real time. For more than 150 different microprocessors. Using the same command set environment.

■ A generous 2730 trace-cycle buffer with selective filtering lets you cut through the clutter and display just the traces you wish. And you get 1μsec resolution in program time measurement. Plus continuous InSight monitoring of your program's key functions as they are performed.



InSight Display. InSight blends analyzer-emulator techniques to give you continuous, real time monitoring of key processor functions. And still services user interrupts. It displays changing register contents, I/O lines, ports, user-defined memory windows. With your own labels.

■ On top of that, you get UniLab's trademark ability to debug by symptom, not just by breakpoint and single step. And, to help you complete the job on time, on the spot, a stimulus generator and EPROM programmer are included.

■ Ease of use, another Orion trademark, is also built in. So you have all the familiar features and formats you're used to working with. It doesn't matter if your project is a single chip controller or complex 16-bit

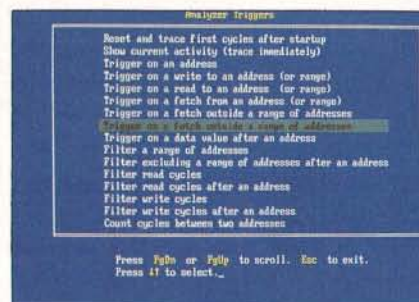

Analyzer Triggers. Commonly used triggers can be selected quickly from a list of standard and user-defined triggers.

microprocessor, the 8620 is the top price/performance analyzer-emulator that does it all. At just \$4380. With processor Personality Paks typically \$550 each.

■ UniLab 8620. Fast-lane debugging that gets you to market quicker.

Call toll-free: 800/245-8500.
In CA: 415/361-8883

ORION
INSTRUMENTS

702 Marshall St., Redwood City, CA 94063
TLX 530942 FAX 415/361-8970

Computer Integrated Instrumentation

Circle 242 on Reader Service Card

PRODUCTS IN PERSPECTIVE

67 What's New

89 Short Takes

NEC Ultralite
NEC ProSpeed
The Norton Commander
Compaq Deskpro 386/20E
Personal Measure

First Impressions

158 The NeXT Computer

Reviews

180 Project management software
197 The Compaq 386s
205 ALR's FlexCache 25386
213 Levco TransLink and CSA PART boards
223 Zortech's C++ 1.0
229 PC-Lint 2.15
237 SpinRite 1.02
241 FullWrite Professional 1.0
249 Remote² 1.0
254 Review Update



IT'S TIME TO DO SOME SERIOUS 386 BUGBUSTING!

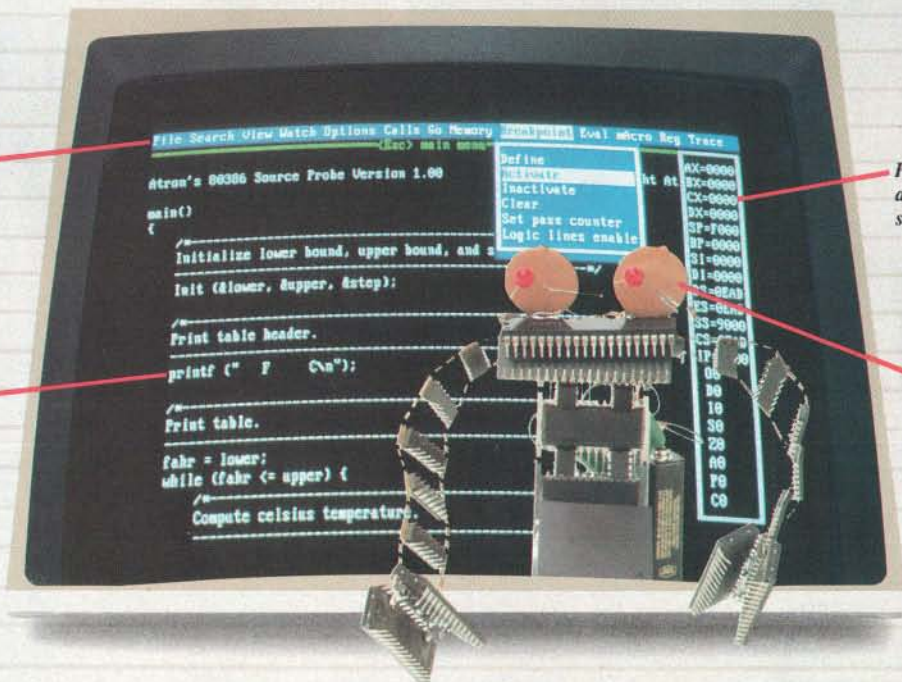

PROBE's menu bar and pull-down menus set a new standard for debugger interfaces.

POP registers up and down with a single key.

PROBE has source-level debugging to let you "C" your program.

This is an out-of-range memory-overwrite bug. Since it is interrupt related, it only appears in real time.

Welcome to your nightmare. Your company has bet the farm on your product. Your demonstration wowed the operating committee, and beta shipments were out on time. Then wham!

All your beta customers seemed to call on the same day. "Your software is doing some really bizarre things," they say. Your credibility is at stake. Your profits are at stake. Your sanity is at stake.

THIS BUG'S FOR YOU

You rack your brain, trying to figure something out. Is it a random memory overwrite? Or worse, an overwrite to a stack-based local variable? Is it sequence dependent? Or worse, randomly caused by interrupts? Overwritten code? Undocumented "features" in the software you're linking to? And to top it off, your program is too big. The software debugger, your program and its symbol table can't fit into memory at the same time. Opening a bicycle shop suddenly isn't such a bad idea.

THIS DEBUGGER'S FOR YOU

Announcing the 386 PROBE™ Bugbuster,*from Atron. Nine of the top-ten software developers sleep better at night because of Atron hardware-assisted debuggers. Because they can set real-time breakpoints which instantly detect memory reads and writes.

Now, with the 386 PROBE, you have the capability to set a *qualified breakpoint*, so the breakpoint triggers only if the events are coming from the wrong procedures. So you don't have to be halted by breakpoints from legitimate areas. You can even detect obscure, sequence-dependent problems by stopping a breakpoint only after a specific chain of events has occurred in a specific order.

Then, so you can look at the cause of the problem, the 386 PROBE automatically stores the last 2K cycles of program execution. Although other debuggers may *try* to do the same thing, Atron is the only company in the world to dequeue the pipelined trace data so you can easily understand it.

Finally, 386 PROBE's megabyte of hidden, write-protected memory stores your symbol table and debugger. So your bug can't roach the debugger. And so you have room enough to debug a really big program.



COULD A GOOD NIGHT'S SLEEP PUT YOU IN THE TOP TEN?

Look at it this way. Nine of the top-ten software products in any given category were created by Atron customers. Maybe their *edge* is — a good night's sleep.

Call and get your free, 56-page bugbusting bible today. And if you're in the middle of a nightmare right now, give us a purchase order number. We'll FEDEX you a sweet dream.



Atron
BUGBUSTERS

A division of Northwest Instrument Systems, Inc.
Saratoga Office Center • 12950 Saratoga Avenue
Saratoga, CA 95070 • Call 408/253-5933 today.

WHAT'S NEW

SYSTEMS

MIDI Meets DOS in a Laptop

Yamaha Music introduced an MS-DOS-compatible laptop that's designed specifically for professional musicians.

At first glance, the C1 seems no different from a standard laptop.

An 8- or 10-MHz Intel 80286 microprocessor is coupled with 64K bytes of ROM, 640K bytes of RAM (upgradable to 1 or 2.5 megabytes), and two 720K-byte 3½-inch floppy disk drives (or an optional 20-megabyte hard disk drive/720K-byte floppy disk drive configuration).

The backlit digital liquid crystal display offers 640- by 400-pixel resolution, and you can connect an external monitor.

Several features, however, distinguish this machine. The first is MIDI compatibility, which you can access through the 11 MIDI ports (2 in, 1 through, and 8 out) that line the back of the 15- by 15- by 3-inch, 18-pound machine.

There's built-in tape synchronization functionality and two sliders on the side of the keyboard for pitch bend, volume, tempo, and other functions that work off music-specific software packages.

Music-specific hardware includes a chip that gives the C1 a system timer.

Also, Yamaha claims that about two dozen third-party software manufacturers are ready to deliver as many as 100 programs.

Price: \$2995; \$3995 with hard disk drive option.

Contact: Yamaha Music Corp., USA, P.O. Box 6600, Buena Park, CA 90622, (714) 522-9011.

Inquiry 753.



Yamaha C1 breaks the music barrier.

Apple Joins the 68030 Bandwagon

A new CPU, floating-point coprocessor, and floppy disk drive controller mark the advanced technology Apple Computer is promoting with the introduction of the Mac IIX computer.

Motorola's 16-MHz 68030 microprocessor has separate instruction and data caches and includes Paged Memory Management hardware that supports shared memory and virtual memory. It also includes the latest-generation 68882 floating-point coprocessor.

Apple says the new floppy disk drive controller and its 1.44-megabyte 3½-inch floppy disk drive, called SuperDrive, can format and read/

write both 400K-byte and 800K-byte Apple floppy disks as well as MS-DOS and OS/2 720K-byte and 1.44-megabyte floppy disks.

Two drive configurations are available: one 1.44-megabyte floppy disk drive, or one 1.44-megabyte floppy disk drive and an internal 80-megabyte SCSI hard disk drive.

The Mac IIX will run Apple's operating system version 6.0. Inside the Mac IIX size, 25-pound Mac IIX are 4 megabytes of on-board RAM (expandable to 8 megabytes). Monitor and keyboard are options.

Price: \$7769; \$9369 with 80-megabyte hard disk drive.

Contact: Apple Computer, Inc., 20525 Mariani Ave., Cupertino, CA 95014, (408) 996-1010.

Inquiry 751.

SEND US YOUR NEW PRODUCT RELEASE

We'd like to consider your product for publication. Send us full information, including its price, ship date, and an address and telephone number where readers can get further information. Send to New Products Editor, BYTE, One Phoenix Mill Lane, Peterborough, NH 03458. Information contained in these items is based on manufacturers' written statements and/or telephone interviews with BYTE reporters. BYTE has not formally reviewed each product mentioned. These items, along with additional new product announcements, are posted regularly on BIX in the microbytes.sw and microbytes.hw conferences.

Wang Supermicro Runs Its Own VS and Unix

Three VS 5000 microprocessor chips provide the Wang VS 5000 with 25 to 33.3 MHz of no-wait-state performance. On each of these scalable CMOS chips is an entire Wang VS instruction set, which the company claims is a variant of the IBM 370 mainframe instruction set.

Wang's VS operating system comes standard, but a Unix-based system called the VS IN/ix is available as an option. All systems are shipped with a 1.2-megabyte 5¼-inch floppy disk drive. Each can also be equipped with one full-height hard disk drive, and one or two half-height hard disk drives, or half-height streaming tape drives.

Model 30 operates at 25 MHz and can handle as many as six terminals. It sports 1 or 2 megabytes of RAM and a 72-megabyte or 145-megabyte hard disk drive.

Model 40 operates at 25 MHz, but it handles up to 16 users, with each system containing 2 megabytes of RAM (upgradable to 8) and your choice of a 72-, 145-, or 326-megabyte hard disk drive.

Model 50 operates at 28.6 MHz for up to 32 terminals with 2 megabytes of RAM (upgradable to 8), and any of the three hard disk drives.

Price: Model 30, \$8800 to \$13,900; Model 40, \$15,200 to \$41,100; Model 50, \$26,200 to \$52,100.

Contact: Wang Laboratories, Inc., One Industrial Ave., Lowell, MA 01851, (508) 459-5000.

Inquiry 752.

continued

Erasable Technology Meets Optical Storage

DISCUS Rewritable is a magneto-optical disk subsystem that's compatible with all MS-DOS- and OS/2-based systems.

It's a 5 1/4-inch, 650-megabyte subsystem that's compatible with the manufacturer's WORM and CD-ROM drives. Operation of the DISCUS is the same as a hard disk drive, except that the optical cartridges are removable. The AGADrive SCSI host adapter is installed in a full-length AT or PS/2 (Micro Channel) slot.

The system reads data from the 3M-designed removable cartridges using an 800-nanometer, 20-milliwatt semiconductor laser diode. The cartridges have a polycarbonate chemical substrate that sandwiches a thin film of "earthen" elements. The laser polarizes (deflects) tiny elements on the thin film, making the writing magneto-optical. All reads are optical.

Price: \$4995; \$250 for cartridges.
Contact: Advanced Graphic Applications, Inc., 90 Fifth Ave., New York, NY 10011, (212) 337-4200.
Inquiry 757.



DISCUS rewrites optical disks.

PC-Based CAD Peripheral for 2 1/2-D

Adra Systems' new PC-based CAD peripheral, Acclaim!, has roughly one-third the storage capacity of its minicomputer-based (CAD) System 3000.

Both systems have 2 1/2-dimensional (2-D that can be viewed from multiple x, y, and z axes) functionality. Both have a quick response time of about 1/10 second. Both functions are perfect for the engineer designing the nuts-and-bolts-type components necessary in any manufacturing facility.

Files can be shared with

other Acclaim! systems, with PCs, or with the Adra 3000 via Transmission Control Protocol/Internet Protocol (TCP/IP) Ethernet or 360K-byte floppy disks. Acclaim! can also be linked to an Adra file server for a multiple workstation environment.

Applications software is Adra's Cadra-II, version 6.0, which works with MS-DOS 3.1 or higher and with IBM PC, XT, and AT compatibles, including PS/2s.

Compatible computers must have at least 20 megabytes of hard disk capacity, a graphics display (EGA and VGA monitors with 1024- by 768-pixel resolution are supported), a keyboard, and a mouse or tablet.

Adra also sells a complete

system, which includes a 10-MHz 80286-based PC (or a 16-MHz 80386-based machine), Acclaim!, a 15-inch VGA color display, and a 40-megabyte hard disk drive. Options include a 19-inch 1024- by 768-pixel display, a data tablet and stylus, and a 40-megabyte tape backup.

Price: \$10,795 to add Acclaim! to your existing system; \$14,995 with an 80286 package; \$17,995 with an 80386 package.

Contact: Adra Systems, Inc., 59 Technology Dr., Lowell, MA 01851, (508) 937-3700.

Inquiry 758.

WORMs That Slither Faster

Maximum Storage is banking on the idea that a permanent WORM (write once, read many times) media will be used for years to come.

The 500-megabyte APX-4000 device is the company's second offering with non-erasable permanence in mind (it is conservatively estimated to last more than 10 years).

The APX-4000, a 5 1/4-inch unit, is coupled with the company's proprietary software for 28-millisecond access time resulting from both coarse- and fine- seek motors. Each drive comes standard with a controller card (XT- and AT-compatible) and an enhanced small device interface port.

Price: External version, \$4450; internal version, \$4250; double-sided cartridges, \$175; single-sided, \$125.

Contact: Maximum Storage, Inc., 5025 Centennial Blvd., Colorado Springs, CO 80919, (719) 531-6888.

Inquiry 756.

continued

RS-232C Modem Doesn't Hog Your RS-232C Port

The XE2400FT is a compact 2400-bps modem that requires no XT- or AT-compatible slots. It doesn't even use up your RS-232C port.

If your RS-232C port is already occupied, you simply unplug that device, plug the XE2400FT into your computer's RS-232C port, and plug the other peripheral into the XE2400FT's RS-232C port. This arrange-

ment gives the Xecom-designed modem the ability to receive and transmit through the telephone lines. Or you can flip a switch and be in direct contact with a printer, a mouse, another computer, or any other serial peripheral device.

The XE2400FT includes many functions. It's compatible with the Hayes AT command set, and it features auto-answer, auto-baud,

auto-dial, and redial functions. It also has a fully programmable set of S registers, for programming the number of rings or dialing time delay, for example.

Price: \$349 with communications software; \$477 with a serial mouse and compatible software.

Contact: Xecom, Inc., 374 Turquoise St., Milpitas, CA 95035, (408) 945-6640.

Inquiry 755.

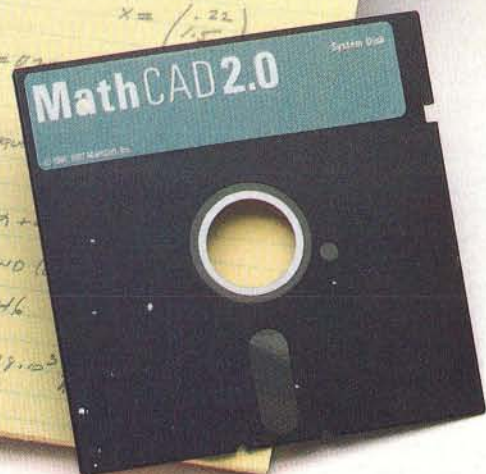
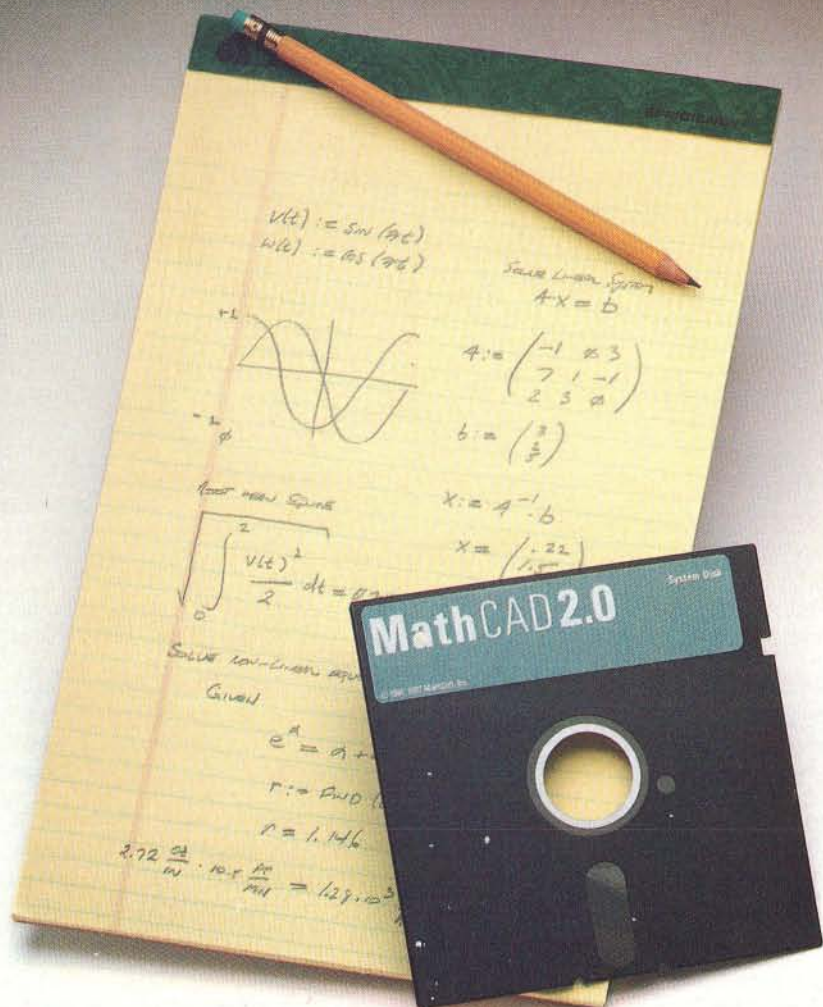

Your pad or ours?

If you perform calculations, the answer is obvious.

MathCAD 2.0. It's everything you appreciate about working on a scratchpad—simple, free-form math—and more. More speed. More accuracy. More flexibility.

Just define your variables and enter your formulas anywhere on the screen. MathCAD formats your equations as they're typed. Instantly calculates the results. And displays them exactly as you're used to seeing them—in real math notation, as numbers, tables or graphs.

MathCAD is more than an equation solver. Like a scratchpad, it allows you to add

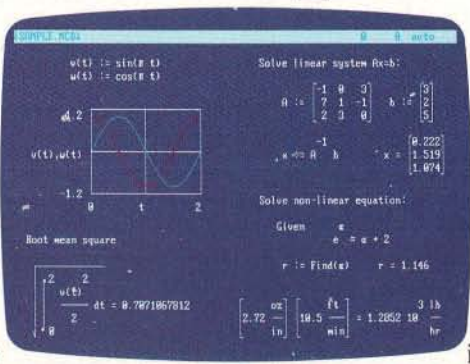

text anywhere to support your work, and see and record every step. You can try an unlimited number of what-ifs. And print your entire calculation as an integrated document that anyone can understand.

Plus, MathCAD is loaded with powerful

built-in features. In addition to the usual trigonometric and exponential functions, it includes built-in statistical functions, cubic splines, Fourier transforms, and more. It also handles complex numbers and unit conversions in a completely transparent way.

Yet, MathCAD is so easy to learn, you'll be using its full power an hour after you begin.

What more could you ask for? How about the exciting new features we've just added to MathCAD 2.0...

- Built-in equation solver
- Full matrix operations
- Two to four times increase in calculating speed
- Easier full-page text processing
- Auto-scaled plots
- Memory enhancements
- Additional printer and plotter support
- And more.

If you're tired of doing calculations by hand or writing and debugging programs, come on over to our pad. MathCAD. The Electronic Scratchpad.

Call for a detailed spec sheet and the name of a MathCAD dealer near you. **1-800-MathCAD** (In MA: 617-577-1017).

Requires IBM PC® or compatible, 512KB RAM, graphics card.
IBM PC® International Business Machines Corporation.
MathCAD® MathSoft, Inc.

MathCAD®

MathSoft, Inc., One Kendall Sq., Cambridge, MA 02139

Bring MS-DOS to Your Mac

Two coprocessor boards allow the Macintosh SE and II to run MS-DOS applications easily, the manufacturer claims. Each fits in a single expansion slot and includes a parallel port for IBM PC-compatible printers and a serial port for RS-232C devices. All you need to add is the operating systems.

MAC/DOS SE, which is based on Intel's 8086, comes with disk-transfer and file-conversion utilities. These permit you to transfer files directly, without having to use an external 5¼-inch floppy disk drive. The SE board also supports Macintosh features (such as font style and size selection for desktop publishing, Multifinder and Switcher, and many Macintosh desk accessories) while operating in the DOS environment.

Memory is 128K bytes of RAM, upgradable to 512K. Macintosh disk drives are assigned and used as DOS disk drives using a logical format. The SE's hard disk drive is partition-configurable from 1 to 32 megabytes.

The **MAC/DOS II** coprocessor board, which is based on Intel's 80286, includes 1 megabyte of expansion memory (upgradable to 2 megabytes) you can use for the Mac when you're not using it to run MS-DOS applications. Besides the parallel and serial ports, there's an optional 80287 math coprocessor socket.

Price: MAC/DOS SE with 128K bytes of RAM, \$795; with 512K, \$1195; MAC/DOS II with 1 megabyte of RAM, \$1495.

Contact: PerfecTek Corp., 1455 McCarthy Blvd., Milpitas, CA 95035, (408) 263-7757.

Inquiry 760.



PerfecTek coprocessing lets Macs run DOS.

NuView Images the Mac II

AST Research has an 8-, 16-, and 24-bit color image-capture card for the Mac II that digitizes and manipulates images from NTSC- and RGB-standard sources. Typical applications vary from desktop presentation and publishing to medical imaging and industrial inspection.

After capturing the image, the single-slot board displays it with up to 640- by 480-pixel resolution through any Apple-compatible video display card (which Apple sells for \$599). The image can subsequently be displayed (digitized to fit within multiple windows of any size), manipulated, stored, printed, or transferred to graphics applications.

Key features include real-time hardware panning and zooming, clipping, and masking. Capture rate is 30

frames per second. The frame buffer is 1.5 megabytes of RAM, and the system palette has up to 16.7 million colors.

Price: \$2099.

Contact: AST Research, Inc., 2121 Alton Ave., Irvine, CA 92714, (714) 863-9991.

Inquiry 763.

LIM/EMS 4.0 Boards from Intel

Above Board Plus and Above Board Plus I/O are Intel products supporting the Lotus/Intel/Microsoft Expanded Memory Specification (LIM/EMS) 4.0 and OS/2 hardware for multitasking capability above 640K bytes on the IBM PC, XT, AT, non-Micro Channel PS/2s, and compatibles.

LIM/EMS offers access to 32 megabytes rather than the conventional 640K-byte limit that can be accessed by applications and utilities such as RAM disks and print spoolers. Since LIM/EMS 4.0 was released, more than a dozen software packages have been revised to support the specification.

With LIM/EMS and a piggyback card, Above Board Plus offers access to 8 megabytes. Memory on Above Board Plus can also be configured to OS/2, or extended memory.

Above Board Plus I/O comes standard with one serial and one parallel port.

Price: Above Board Plus, \$745; Above Board Plus I/O, \$895; piggyback memory board configured with 2 megabytes, \$2195.

Contact: Intel PCEO, Mail Stop C03-07, 5200 Northeast Elam Young Pkwy., Hillsboro, OR 97124, (800) 538-3373.

Inquiry 762.

continued

CATV-Delivered Video Meets the PC

One of the first consumer products involving data processing of cable television-delivered video is now available from CableSoft.

LiveWire allows you to keep up with your stock market portfolio through the Financial News Network while you're in an application in the DOS environment. Any time your PC, XT, AT, or compatible is tuned into FNN, delivered by your local cable television franchise, you've got the most up-to-date stock quotes available.

Coprocessor multitasking allows LiveWire to signal

you from within your application to buy, sell, stop buying, or stop selling when prices reach preset levels.

Included software allows for multiple portfolio management with cash accounting. There's 64K bytes of ROM and 8K bytes of RAM for storage of historical data for securities, indexes, and portfolios. Software is included for some technical analyses of the historical data.

Price: \$995.

Contact: CableSoft, Inc., 307 West Burlington Ave., Fairfield, Iowa 52556, (515) 472-8393.

Inquiry 761.

It's Easy To See Why Quattro Is The Spreadsheet Of Choice!

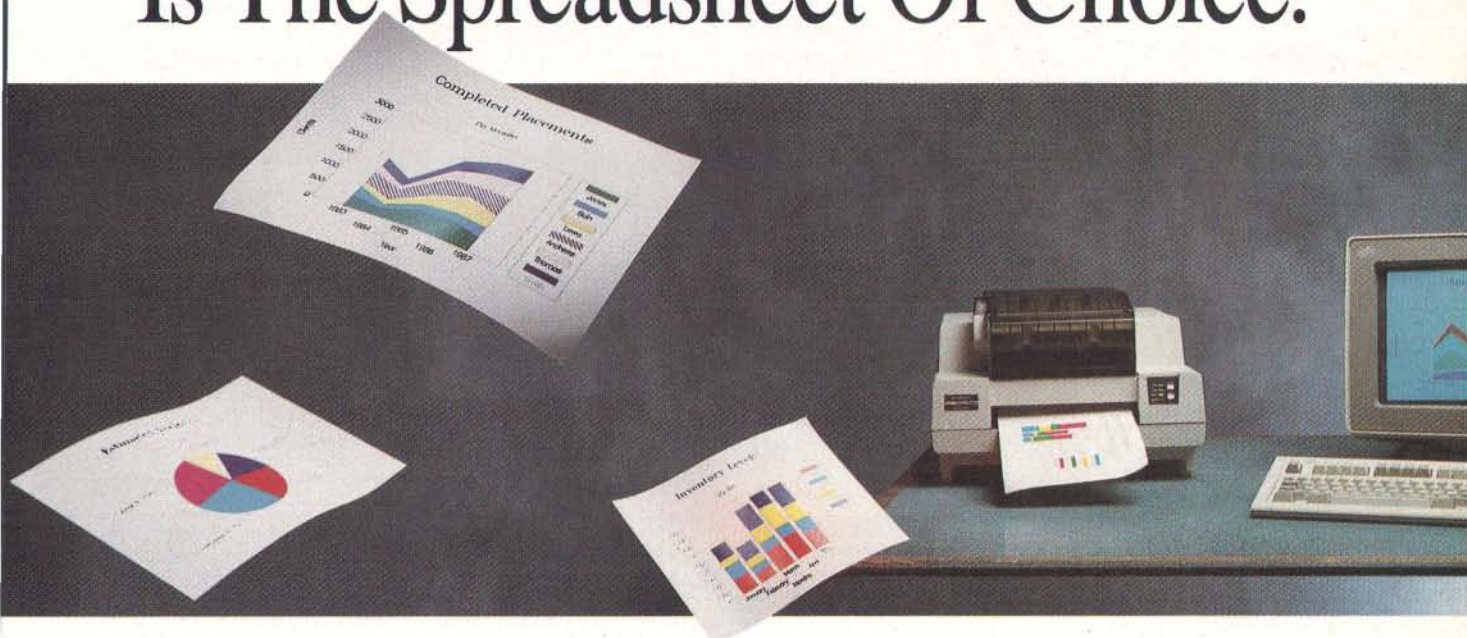

In fact, it's hard *not* to see. Because one look at Quattro® shows you a lot more for your money. More speed, more power, and the most spectacular presentation-quality graphics anywhere—built in.

Dazzling and diverse

If you went out looking, you'd be hard pressed to find spreadsheet graphics as dazzling and diverse as Quattro's. If you did, they'd be in a separate standalone package with a separate standalone price. And they still wouldn't be integrated with your spreadsheet's menu commands the way Quattro's are.

Brilliance built in

Quattro lets you choose from 10 different types of presentation-quality graphs and a huge selection of fonts, fill patterns and colors.

Quattro supports PostScript® too. So you can use today's most popular laser printers and typesetters to make your work—and yourself—look positively brilliant.

Hard copy made easy

Quattro makes it easy to get hard copies of your graphics—with a printer or plotter, directly from the spreadsheet. In fact, you don't even have to leave the spreadsheet.

Seeing is believing!

Dazzling graphics are just one of Quattro's eye-opening features; your dealer can show you the others. Quattro is easy to use and fully compatible; it even accepts familiar 1-2-3® compatible commands and uses data files created with other spreadsheets and databases. But Quattro gives you a lot more—in fact, twice the speed and power of the old standard. For only half the price.

60-Day Money-back Guarantee*

For the dealer nearest you
call (800) 543-7543

“ Quattro contains the most comprehensive presentation graphics capability available in a spreadsheet . . . The graphs Quattro can produce surpass even those available through add-on products like Lotus Graphwriter or Freelance Plus. If Borland wanted to, it could certainly sell the graphics portion of the spreadsheet on its own merit as a standalone graphics application.

Robert Alonzo, Personal Computing

Quattro's presentation-quality graphics output capabilities rival those that 1-2-3 can obtain only in conjunction with separate presentation graphics software . . . For me, at least, Quattro has certainly become the character-oriented spreadsheet program of choice.

William Zachmann, Computerworld

In the few years since Lotus Development Corp. introduced 1-2-3, many companies have attempted to unseat the king of the spreadsheet hill. The latest contender, Borland International Inc.'s Quattro, succeeds where other spreadsheet packages have failed . . . Quattro is at least two steps ahead of 1-2-3.

Ricardo Birmele, PCResource ”

*Customer satisfaction is our main concern. If within 60 days of purchase this product does not perform in accordance with our claims, call our customer service department, and we will arrange a refund.

All Borland products are trademarks or registered trademarks of Borland International, Inc. Lotus and 1-2-3 are registered trademarks of Lotus Development Corp. Other brand and product names are trademarks of their respective holders. Copyright © 1986 Borland International, Inc. B1 1236A



Circle 52 on Reader Service Card (DEALERS: 53)

Gateway Merges Token Ring and Ethernet

If you have PCs on both token rings and Ethernets, Harris Corp. has the SuperNet Gateway to connect both types of local-area networks together while providing you with an instant upgrade path to the minicomputer and mainframe worlds.

It allows you to hotkey from PC applications (through either your token ring or Ethernet) to other PC applications and in turn to mainframe applications, and vice versa, through the most standard protocols, like TCP/IP and SNA.

PCs, 3270 coaxial terminals, asynchronous terminals, it doesn't matter. IBM hosts, async hosts, Unix, MS-DOS. Same thing. A few of the issues Harris has addressed are terminal emulation, file transfer, and program-to-program communications.

In its base configuration, Model 20 is a 16-MHz, 80386-based server. Harris sells it stripped down with 4 megabytes of RAM; a 1.2-megabyte floppy disk drive; a 40-megabyte hard disk drive; a 150-megabyte tape drive; console; diagnostic modem; one 32-bit, four 16-bit, and two 8-bit slots; and a Unix license.

Model 30 is based on a 20-MHz 80386 microprocessor. It has 4 megabytes of RAM and comes standard with an 80-megabyte hard disk drive and four 32-bit, five 16-bit, and three 8-bit expansion slots.

Both models operate under Unix System V with "MS-DOS as a guest."

Price: Model 20, under \$14,000; Model 30, \$21,000.
Contact: Harris Corp., Data Communications Division, 16001 Dallas Pkwy., Dallas, TX 75248, (214) 386-2000.
Inquiry 764.

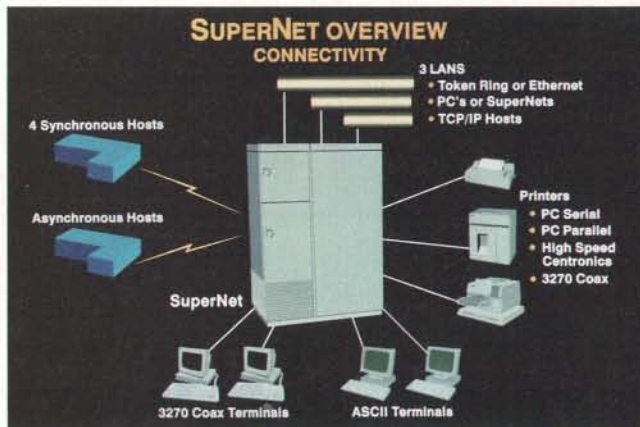

Harris links token rings, Ethernets, and more.

Ethernet Learns LocalTalk, and Vice Versa

FastPath 4 is designed to provide a gateway between Ethernet and Apple's LocalTalk, using either thin or standard coaxial cabling.

Compared to the previous Kinetics' Ethernet/LocalTalk gateway, memory for processing and buffers between the 10-megabit-per-second data-transfer rate and the 230-kilobit-per-second data-transfer rate has been beefed up to 256K bytes, upgradable to 512K.

Optional configuration and network-management software, called K-Star, can be loaded to FastPath 4 from any Macintosh on the network. Automatic address management is also provided with K-Star, allowing Internet Protocol (IP) addresses, which are necessary for communication with an Ethernet host speaking Transmission Control Protocol/Internet Protocol (TCP/IP).

Price: \$2495.
Contact: Kinetics, Inc., 2540 Camino Diablo, Walnut Creek, CA 94596, (800) 433-4608; in California, (415) 947-0998.
Inquiry 852.

The GatorBox provides an Aperture File Protocol (AFP) to Network File System (NFS) protocol translation to a LocalTalk-to-Ethernet gateway, Cayman Systems claims.

This precludes the need to install any software on the AFP clients or the NFS servers. This functionality allows Macintoshes running Apple's AppleShare workstation software to always "see" NFS servers as AppleShare servers. NFS servers similarly see each Macintosh that uses the GatorBox as an ordinary NFS client.

Price: \$3495.
Contact: Cayman Systems, Inc., University Park at MIT, 26 Lansdowne St., Cambridge, MA 02139, (617) 494-1999.
Inquiry 767.

Increase AppleTalk Beyond 230K bps

DaynaTalk, a connector box for Apple Macintoshes and IBM PC, XT, AT, PS/2s (Models 25 and 30), and compatibles, increases data rates beyond the 230,000 bps of LocalTalk.

Data rates depend on the bus structure, according to manufacturer Dayna Communications. That means that this connector box increases the data-transfer rate to 750K

bps when coupled with a Mac Plus, 800K bps with the Mac SE, and 850K bps with the Mac II.

The AT bus allows the connector box to boost the data-transfer rate to 1.7 megabits per second. One connector box is required between each LocalTalk machine, or the data rate will default to 230K bps. Several network operating systems are supported, including AppleShare, NetWare, and TOPS.

Price: Macintosh version, \$189; IBM version, \$289.
Contact: Dayna Communications, Inc., 50 South Main St., Fifth Floor, Salt Lake City, UT 84144, (801) 531-0203.
Inquiry 766.

Token-Ring Device Adds to Number of PCs per Node

One Local Ring Hub from Madge Networks lets you add four PCs (equipped with token-ring cards) to the twisted-pair cabling between a token-ring multiple-access unit (MAU) and the PC on your desk.

Token-ring MAUs, which are generally placed in wiring closets up to 100 meters from the PCs, are standard equipment on a token-ring local-area network—the second most popular LAN.

Daisy chain up to two hubs off the first one and you can support a total of 10 PCs within that same 100 meters of cabling.

Price: \$445.
Contact: Madge Networks, Inc., 534 Salem Ave. SW, Roanoke, VA 24016, (800) 876-2343; in Virginia, (703) 982-0638.
Inquiry 765.

continued

A child doesn't understand a hard disk crash. To her, lost data only means her mother won't be home until late.

At Everex, we know that lost data means more than just time and money. That's

Lost Data Means Lost Opportunities

why we make a complete line of high quality tape backup products. We don't cut corners when

the security of your data is at stake.

You don't get a second chance to recover what you've already lost.

Everex tape backup systems. Because little girls can't wait.



EVEREX

48431 Millmont Drive • Fremont, California

1-800-821-0806

1-800-821-0807 in California

See Everex Products at Comdex
Las Vegas Hilton, Booth H8406

Circle 126 on Reader Service Card (DEALERS: 127)

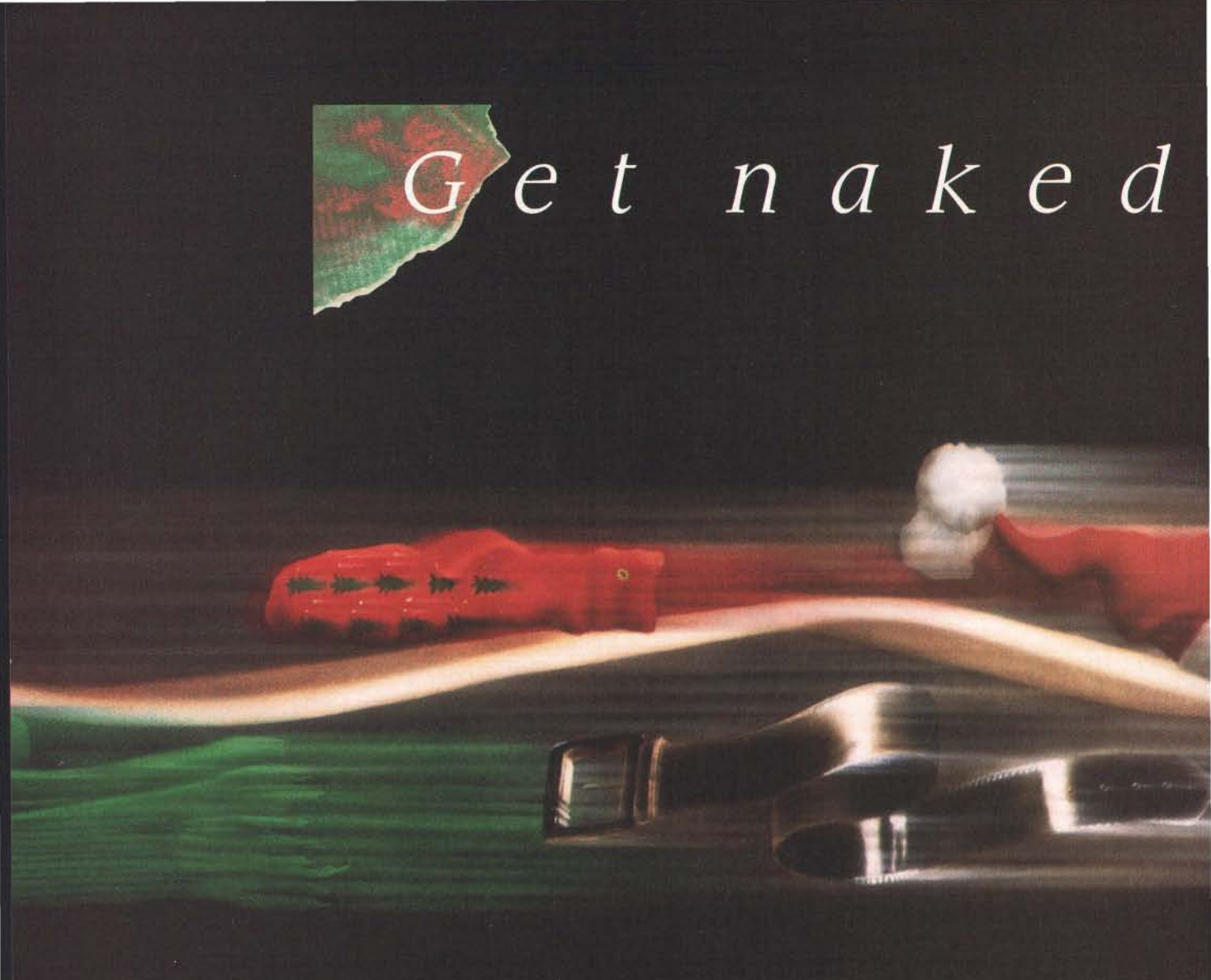

Get naked

ClearCase™ Mouse—Special Edition From Logitech.

To celebrate the shipment of our two millionth mouse, we took the covers off our winning technology.

But this mouse is a lot more than just a pretty case. It's compatible with virtually all mouse-based programs, plus you can program it to "mousify" any keyboard-based application. And it doesn't need resetting when you switch programs.

High resolution, adjustable cursor control, and a programmable 9,600 baud rate let you move the cursor quickly and accurately, even on detailed graphics—perfect for applications

for Christmas.

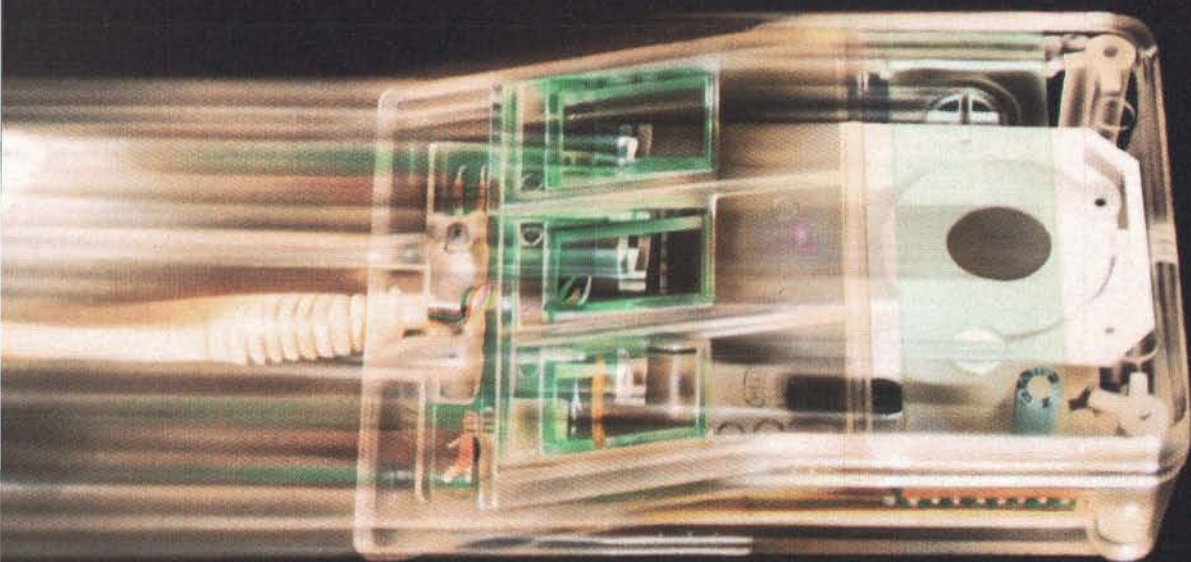

like PaintShow™ which, it so happens, comes with your ClearCase Mouse.

You get everything for \$149. The package includes: the Logitech ClearCase Mouse for IBM PC, XT, or AT and PS/2 or 100% compatibles; a 9-25 pin adapter; Plus Package™ software; and Logitech PaintShow™ (which requires a graphics card).

*Pick up the ClearCase Mouse
at your computer dealer,
or call: 800-231-7717.
(In California call
800-552-8885.)*



LOGITECH
Personal Peripherals. Worldwide.

Circle 193 on Reader Service Card (DEALERS: 194)

Tablet Features Absolute Positioning

Kurta's intelligent graphics tablets, called IS/ADB input systems, plug directly into the Apple Desktop bus on the Mac II and SE (leaving serial ports free).

There are three features novel to this pointer/tablet combination (with corded pen and interface software). Each unit incorporates absolute positioning, macro commands, and keys to scale your work to fit the size of the screen or window you are using.

Absolute positioning means that every point on the tablet corresponds exactly to a point on the screen, whether you're using the 8½-by-11-inch, the 12-by-12-inch, or the 12-by-17-inch tablet. The tablet can also handle up to ½-inch-thick documents.

Along the top of the tablets are 23 programmable function keys, which can be loaded with macros such as "align, save, and print." Loading the keys with macros is a function of Apple's MacroMaker, which is designed so you don't have to pull down multiple menus every time you do a standard set of commands.

Of the five scale functions available, Std scales the tablet itself to an Apple-defined active screen, and Win scales the tablet to whatever window is



Kurta's ergonomics breakthrough.

active, for example.

Optional equipment includes cordless pens and corded or cordless four-button cursors, with buttons that can be programmed to execute command sequences just like the function keys.

Price: 8½-by-11-inch tablet, \$395; 12-by-12-inch tablet, \$595; 12-by-17-inch tablet, \$965; to upgrade models purchased before August, \$50. Free upgrade for models purchased in August and September.

Contact: Kurta Corp., 4610 South 35th St., Phoenix, AZ 85040, (602) 276-5533. **Inquiry 768.**

Bright Future for GW3

GW3 introduced a single board computer for industrial control problems. Motorola's 68020 and 68881 are the CPU and floating point-processor.

The SBC-20 includes 128K bytes to 2 megabytes of RAM, an EPROM socket, two asynchronous serial ports, and six interrupt levels.

Key features of the SBC-20 include the following: 32-bit data path to on-board RAM, 32-bit data path to on-

board floating-point processor, and a real-time multitasking executive in EPROM that includes file management and multitasking BASIC.

Price: \$764 to \$1440.

Contact: GW3, Inc., 7623 Fullerton Rd., Springfield, VA 22153, (703) 451-2043.

Inquiry 771.

More Accurate Than Your Standard Rodents

Thanks to optical technology and software, nine speed settings and effective resolution of 2000 counts per inch are available through MSC Technologies' Microsoft-compatible PC Mouse II. Actual resolution is 200 counts per inch without the software.

It connects to your serial port through a 9-foot cable and includes an 11.8K-byte driver for your CONFIG.SYS file. It's compatible with the IBM PC, XT, AT, and compatibles and features an automatic install program, designer pop-up menus, and a menu compiler. Standard accessories include a mouse pad and PC Paint Plus graphics software.

Price: \$149; \$179 bundled with Autosketch. **Contact:** MSC Technologies, Inc., 47505 Seabridge Dr., Fremont, CA 94538 (415) 656-1117.

Inquiry 769.

continued

Multiply Lab Instruments by One Macintosh

The MacAdios II Jr and MacInstruments software from GW Instruments lets your Mac II emulate oscilloscopes, scan-line recorders, chart recorders, and other types of common laboratory equipment.

This configuration gives the analog and digital I/O

board the ability to record one channel at 25,000 samples per second while concurrently plotting to the screen.

The MacAdios II Jr plugs into one of the Mac II expansion slots. It is then ready to provide 16 analog input channels, 2 analog output

channels, 8 digital input channels, 8 digital output channels, and three counter/timer channels.

Optional TurboDriver software is capable of digitizing waveforms at up to 833 kHz in the oscilloscope mode, 25 MHz in the chart recorder mode, 60 Hz in the

scrolling strip chart recorder mode, and 16 kHz in the scan-line recorder mode.

Price: \$890, not including software.

Contact: GW Instruments, Inc., 35 Medford St., Somerville, MA 02143, (617) 625-4096.

Inquiry 770.

SQL Top Gun School

\$199



All the database Top Guns are flying SQL, the industry-standard data management language first delivered by Oracle. Why? Because one SQL statement replaces up to 20 lines of dBASE code. And because all the powerful multi-user and distributed databases use SQL — exclusively.

Now you can turn your PC into a SQL trainer that will make you a database top gun: Introducing SQL*Tutor from Oracle, only \$199.

Become an instant SQL ace.

After using SQL*Tutor, you'll be able to:

- Construct simple and complex queries
- Create tables, views and indexes
- Manipulate information in data tables
- Create reports
- Use ORACLE's powerful SQL extensions

Lost that Lovin' Feeling for dBASE?

Everybody has. And now, they're learning SQL. SQL*Tutor is the perfect way to get ready for the emerging SQL database world. Use it to introduce SQL to your entire organization, to offer SQL refresher courses, or as a supplement to documentation.

Or if you're already sold on SQL, then order Professional ORACLE today for \$1295,* and get SQL*Tutor free.

According to PC Week, Professional ORACLE is "the most versatile database management system available on the PC." It includes the ORACLE

SQL database engine, utilities and Oracle's 4th-generation application development tools.

Professional ORACLE is network-ready, and is the same ORACLE that

runs on minis and mainframes. Use it as your standard PC workgroup database, and to provide connectivity to corporate data.

Call 1-800-ORACLE1, ext. 4909 today. Or fill out and AIR MAIL the attached coupon. So your squadron can fly the latest database technology into the 1990s.



Dear ORACLE...

PC Marketing • 20 Davis Drive • Belmont, CA 94002
1-800-ORACLE1, ext. 4909

Enclosed is my check or VISA MC
 AMEX credit card number and authorization for (check only one)

\$199 for online SQL*Tutor and *Introduction to SQL* so I can start developing in SQL.

\$1295 for Professional ORACLE, which includes SQL*Tutor.

\$ _____ Please add appropriate sales tax.

\$ _____ **Total.** I understand Oracle pays shipping, and this offer is valid in the U.S. only.

NAME _____

TITLE _____

COMPANY _____

STREET (no P.O. Boxes, please) _____

CITY _____

STATE _____ ZIP _____

PHONE _____

CREDIT CARD NO. _____ CARD EXPIRATION DATE _____

SIGNATURE _____ TODAY'S DATE _____ BYTE _____

ORACLE®

COMPATIBILITY • PORTABILITY • CONNECTABILITY

Call 1-800-ORACLE1, ext. 4909 today.

Copyright © 1988 by Oracle Corporation
ORACLE is a registered trademark of Oracle Corporation
dBASE is a trademark of Ashton-Tate
*Requires an 80286/80386 PC with 640KB RAM plus
1MB of extended memory, running DOS 3.0+. TRBA

20 Davis Drive, Belmont, CA 94002 • World Headquarters
(415) 598-8000 • Calgary (403) 265-2622 • Ottawa (613) 238-2381 •
Quebec (514) 337-0755 • Toronto (416) 596-7750 • ORACLE Systems
Australia 61-2-959-5080 • ORACLE Europe 44-1-948-6911 •
ORACLE Systems Hong Kong 852-5-266846

Finding It All On-Line

If you're the type of programmer who spends more time trying to find obscure entries in manuals (or trying to find the books themselves) than writing code, Microsoft has a new product that's designed to make your life easier and more productive. The Microsoft Programmer's Library (MPL) is a CD-ROM that gives you immediate on-line access to a comprehensive collection of books, technical manuals, and sample programs.

The MPL contains 48 books and technical manuals that are grouped into nine different categories: OS/2, Windows, MS-DOS, C, BASIC, Microsoft Macro Assembler, Pascal, FORTRAN, and hardware.

Each category has all the technical manuals for the languages and operating systems, as well as sample code organized into multiple files that are indexed and cross-referenced.

Also included are several books, including *Inside OS/2*, *Programming Windows*, *The MS-DOS Encyclopedia*, *Advanced MS-DOS*, *Proficient C*, and *Programmer's Guide To PC and PS/2 Video Systems*.

The MPL is memory-resi-

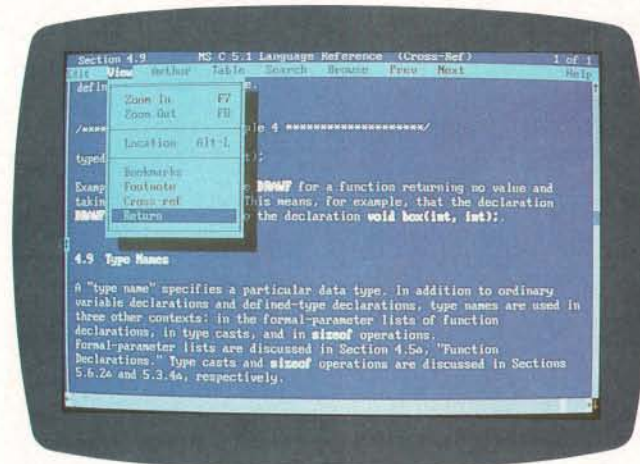

Microsoft crams 48 manuals onto a CD-ROM.

dent, and Microsoft says it's compatible with a wide range of text editors and word processors. You can instantly remove it from memory if you need maximum RAM space for large compiles. To use the MPL, you'll need an IBM PC, XT, AT, PS/2, or compatible with 640K bytes of RAM, a CD-ROM player, and MS-DOS 3.1 or higher. A hard disk drive is recommended.

Microsoft says a no-charge update will be available in early 1989 that will contain documentation for the OS/2 Presentation Manager and LAN Manager.

Price: \$395.

Contact: Microsoft Corp., 16011 Northeast 36th Way, P.O. Box 97017, Redmond, WA 98073, (800) 426-9400; in Washington, (206) 882-8080.

Inquiry 772.

Spread a Little JAM on Your Application

JYACC says that JAM (JYACC Application Manager) is an application generator, application environment, prototyper, and (last but not least) a methodology that promotes parallel applications development. The bottom line is that if you're an applications developer, JAM lets you design and link together user-interface screens without having to do any programming.

You use JAM to create the screens, windows, and menus that make up an application and to specify the control flow among them. The result is a prototype, which the company calls an *applications shell*.

To make the prototype into a real working program, you

write the transaction processing routines and link them with the applications shell. You can even have the applications shell call existing programs directly.

JAM includes full screen-painting facilities, including support for windows, menus, and color. The package is shipped with JYACC For-Maker, a context-sensitive screen and window manager. Versions of JAM are available for a wide range of systems from the PC all the way up to the VAX. They run under MS-DOS, Unix, VMS, and other operating systems.

Price: Starting at \$750.
Contact: JYACC, Inc., 116 John St., New York, NY 10038, (800) 458-3313; in New York, (212) 267-7722.
Inquiry 774.

ROM Your C Programs

If you're a developer who wants to use C for developing embedded systems, the C86PLUS/ROM Development System is for you. It's a complete ROM development system for the Intel 80x86 family of processors.

The system includes the ANSI-standard C86PLUS/ROM C compiler, an Intel-compatible linker/locator, runtime library source code, and a ROM-image symbolic debugger. The package also supports math coprocessors for the Intel 80186/286/386.

The C86PLUS/ROM Development System runs under MS-DOS and lets you use both C and assembly language to produce programs for embedded systems.

Price: \$1300; C compiler alone, \$750.

Contact: Computer Innovations, Inc., 980 Shrewsbury Ave, Tinton Falls, NJ 07724, (201) 542-5920.

Inquiry 776.

A Pop-up Programmer's Calculator

Another programmer's productivity tool comes from Texas-based Falk Data Systems. It's called PrgCalc, and it's a memory-resident programmer's calculator that works with binary, octal, decimal, and hexadecimal numbers while taking up about 50K bytes of RAM. It displays results in all four numeric for-

mats simultaneously and supports all major bit-level manipulations, including shift-left and shift-right.

The package is shipped with PrgCalcM, a version of the calculator that you can run as a background task under DESQview or TaskView. You can also run PrgCalcM as a stand-alone program under MS-DOS.

PrgCalc requires an IBM PC, XT, AT, PS/2, or compatible and MS-DOS 2.0 or higher. It comes with a setup program and a student-oriented tutorial.

Price: \$29.95.

Contact: Falk Data Systems, 5322 Rockwood Court, El Paso, TX 79932, (915) 584-7670.

Inquiry 773.

continued

6 ways Genoa takes the gamble out of data backup.



It isn't the hardware or the software, it's the data that's the most valuable part of your personal computer. The hundreds of hours spent creating and editing data, plus its inherent value to your operation, make it priceless.

Protect that expensive data with a dependable backup system. Only Genoa's Galaxy family of tape backup systems offers 6 high-performance advantages in data protection.

1. On-Line

Galaxy software provides on-line network support. Galaxy and Galaxy/MC tape backup systems come with Genoa's Novell Advanced Network 86 or 286 compatible software driver, a \$200.00 value, *free!*

2. Fast

At 5MB a minute, Galaxy systems are among the fastest tape backups around. You can back up the whole data file in just a few minutes.

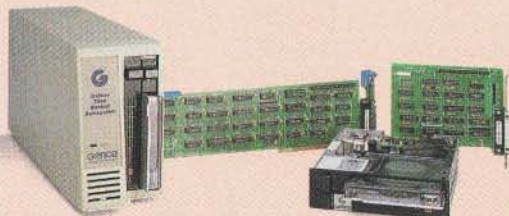

Pictured are our internal and external cartridge backups for IBM PC/XT/ATs.

Come see us at COMDEX/FALL Booth #1078 in the LVCC

© 1988 Genoa Systems Corporation. Galaxy is a trademark of Genoa Systems Corporation. NetWare is a registered trademark of Novell, Inc. IBM, PC, XT, AT, and PS/2 are trademarks of International Business Machines.

3. Easy

Simple command menus make Galaxy systems so easy to operate, most users can start backing up data within minutes.

4. Automatic

Never again will you worry about forgetting to back up data. Galaxy's autoscheduler feature lets you preset an exact date and time, then it

automatically does the backup for you.

5. Reliable

Galaxy boasts one of the lowest return rates in the industry. Plus a full year warranty.

6. IBM Compatible

Galaxy works with all IBM PCs and compatibles, including the new Micro

Channel. For the PC/XT/AT, there are external and internal models. Both are available in cassette and cartridge versions. We also offer a SlimBox model for the PC/XT/AT. It's an efficiently sized external cassette system.

For the Galaxy dealer nearest you, contact Genoa, 75 E. Trimble Rd., San Jose, CA 95131.

Fax: (408)

434-0997. Telex: 172319. Phone: (408) 432-9090. Or fill out the coupon below, we'll send you more information. You've got nothing to lose—except the most valuable part of your personal computer.



The Galaxy Micro Channel family makes it possible to exchange data between IBM PC/XT/ATs and PS/2 models 50, 60 and 80.



I want to protect my investment in data!

Please send me more information on Galaxy tape backup subsystems.

Name _____
 Title _____
 Company _____
 Address _____
 City _____ State _____ Zip _____
 Phone (_____) _____ Ext. _____

Please check all that apply: PC XT AT
 PS/2, Model 50 PS/2, Model 60 PS/2, Model 80

Mail to: Geri Scheer, Genoa Systems Corporation,
 75 E. Trimble Rd., San Jose, CA 95131

Designs in the Real World

Though its name sounds like something out of a Saturday-morning children's television show, Mac Architrion is a serious product indeed. Running on the Mac Plus, SE, and II, it's a complete design, drafting, presentation, and quantity take-off package for architects and builders.

If you design buildings, Mac Architrion's purpose is to let you conceive and develop a project from start to finish. You can do design, delineation, and working drawings, and extract tables of data for costs.

Mac Architrion consists of three main modules: 3D, 2D, and a Quantifier. The 3D designer begins with each point in a plane existing as a perpendicular line. According to the company, this allows you to immediately create blocks of "real" space, rather than using wire diagrams.

The 2D drafting module allows for automatic and manual dimension strings and automatically linked multiple parallel lines. It has over 40 additional tools.

Finally, the Quantifier module gives you both a space-by-space breakdown and an overall breakdown of a project. You can then use the data in a word processor or a



Mac Architrion turns ideas into on-screen reality.

spreadsheet.

Price: \$1499.

Contact: Gimeor, Inc., 1815 H St. NW, Washington, DC 20006, (202) 223-4373.

Inquiry 778.

Simnon Explores the Nonlinear World

The company name ESC doesn't stand for "escape"; it stands for Engineering Software Concepts. And its latest product—Simnon/PC 2.11—is short for Simulation Language for Nonlinear Systems.

The package automatically compiles numerical solutions to differential and difference equations, producing 8086/8087 machine code.

Because the world we live in is essentially nonlinear, the company says that Simnon/

PC is being used to study a wide range of subjects such as chaos, eye movement, and the control of pulp in paper-processing plants. It's also being used to design jet engines, perform research in robotic manipulators, study rockets and aircraft, and even track economic models.

ESC says version 2.11 of Simnon/PC is about twice as fast as version 1. It includes new functions and provides support for PostScript and HP LaserJet printers. To use Simnon/PC, you'll need an IBM PC, XT, AT, PS/2, or compatible with a math coprocessor and at least 256K bytes of RAM (640K bytes is recommended).

Price: \$695.

Contact: Engineering Software Concepts, Inc., 436 Palo Alto Ave., Palo Alto, CA 94301, (415) 325-4321.

Inquiry 779.

Binary Upgrades Tech*Graph*Pad

It's the third time around for Tech*Graph*Pad, which its maker calls engineering data software. The package integrates data retrieval, data manipulation, and data output for scientists and engineers.

Tech*Graph*Pad 3.0 includes a number of new features. For instance, there's a worksheet browse mode that lets you bring up Lotus 1-2-3, Symphony, or Quattro spreadsheets for direct retrieval of data. Binary Engineering has also updated the package's user interface and added support for the HP LaserJet, PaintJet, DeskJet, and other HPGL-compatible devices.

Among the other new features of version 3.0 are that Tech*Graph*Pad now reads and plots unlimited data points per set and provides built-in error bars, superscripts, subscripts, and major/minor axis increments. The package also directly imports binary or two's complement data files generated by real-time data acquisition devices and creates .PIC graphics files.

Price: \$395; upgrade from version 2.0, \$99.

Contact: Binary Engineering, 100 Fifth Ave., Waltham, MA 02154, (617) 890-1812.

Inquiry 781.

continued

MathCAD Adds Advanced Math

Those of you who use MathCAD and don't want to reinvent the wheel for solving specific computational problems might just find nirvana in MathSoft's recent release of the Advanced Math Applications Pack. The first in a series of planned applications, the Advanced Math package is a

collection of mathematical models that you can load into MathCAD and immediately calculate and graphically display the results.

Packed into this first Applications Pack are software and documentation for 16 frequently performed computational tasks including differential equations, real

and complex Eigenvalues and Eigenvectors, convolutions, polynomial least-square fit, digital filtering, conformal mapping, diffusion, the Laplace equation, and static equilibrium.

You can also customize any or all of the models for your specific requirements. In order to take advantage of

all that the Advanced Math Applications Pack has to offer, you'll need a system running MathCAD 2.0.

Price: \$40.

Contact: MathSoft, Inc., One Kendall Sq., Cambridge, MA 02139, (800) 628-4223; in Massachusetts, (617) 577-1017.

Inquiry 780.

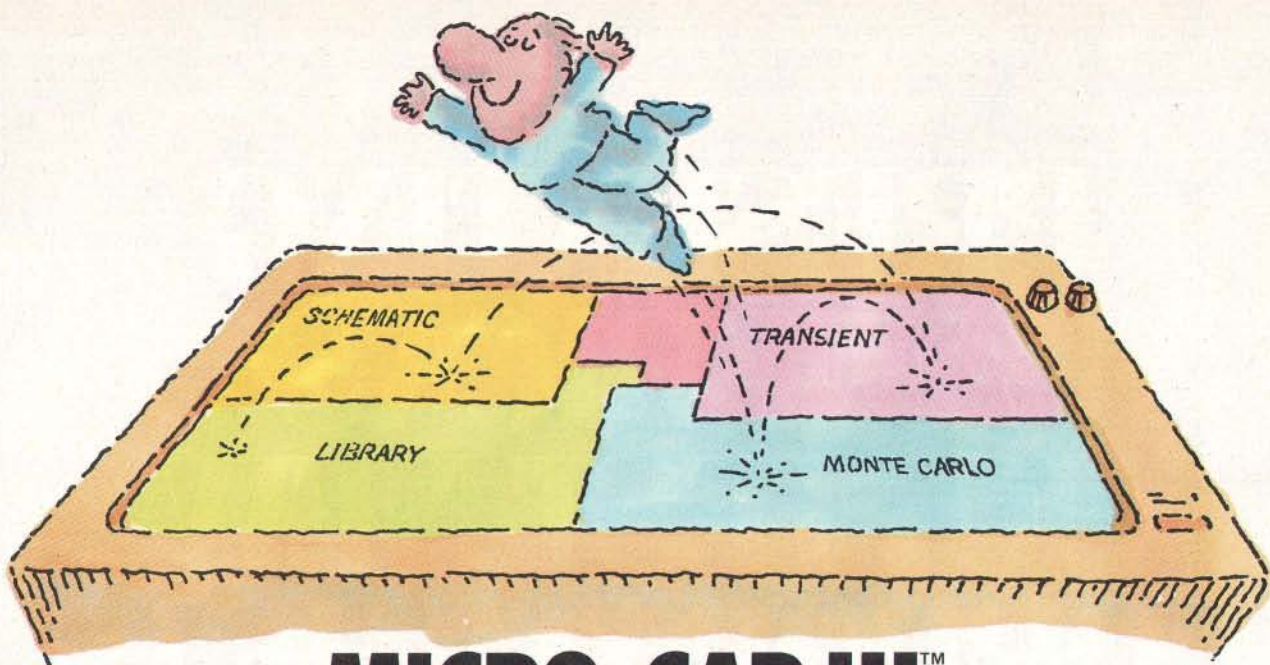

MICRO-CAP III.™ THIRD-GENERATION INTERACTIVE CIRCUIT ANALYSIS. MORE POWER. MORE SPEED. LESS WORK.

MICRO-CAP III,™ the third generation of the top selling IBM® PC-based interactive CAE tool, adds even more accuracy, speed, and simplicity to circuit design and simulation.

The program's window-based operation and schematic editor make circuit creation a breeze. And super-fast SPICE-like routines mean quick AC, DC, Fourier and transient analysis — right from schematics. You can combine simulations of digital and analog circuits via integrated switch models and macros. And, using stepped component values, rapidly generate multiple plots to fine-tune your circuits.

We've added routines for noise, impedance and conductance — even Monte Carlo routines for statistical analysis of production yield. Plus algebraic formula parsers for plotting almost any desired function.

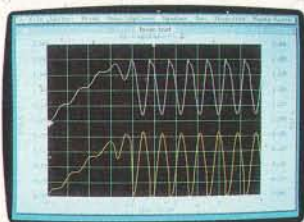

Transient analysis

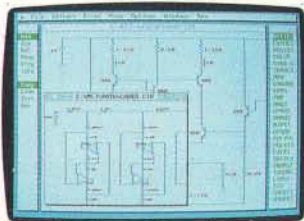

Schematic editor

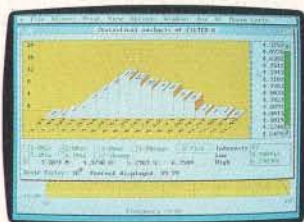

Monte Carlo analysis

Modeling power leaps upward as well, to Gummel-Poon BJT and Level 3 MOS — supported, of course, by a built-in Parameter Estimation Program and extended standard parts library.

There's support for Hercules®, CGA, MCGA, EGA and VGA displays. Output for laser plotters and printers. And a lot more.

The cost? Just \$1495. Evaluation versions are only \$150.

Naturally, you'll want to call or write for a free brochure and demo disk.

spectrum

1021 S. Wolfe Road,
Sunnyvale, CA 94086
(408) 738-4387

MICRO-CAP III is a registered trademark of Spectrum Software.
Hercules is a registered trademark of Hercules Computer Technology.
IBM is a registered trademark of International Business Machines, Inc.

PRESENTING AMERICA'S HOTTEST NEW CORPORATE JETS.

FIVESTAR'S fleet of powerful business computers have really taken off in the last three years. That's because they're built for corporations that want to get where they're going in a hurry.

We build a full line of high-powered performers that not only provide *total* PC compatibility and advanced business capabilities, but also offer American-made ingenuity, quality and value.

In fact, when you *really* compare, you'll find that FIVESTAR Computers leave the competition far behind.

FIVESTAR 286's. **The performance to fly through heavy workloads.**

FIVESTAR 286's provide the features and performance aggressive companies need to reach higher corporate goals. In fact, they're designed to run future as well as current operating systems.

The 286/10 is powered by an Intel 80286 microprocessor that operates at a fast 10 MHz, with zero wait states. With 640KB memory and 1.2MB floppy disk drive, you'll soar through today's popular business applications. Serial, parallel and game ports, and an enhanced 101-key keyboard, provide in-flight convenience.

The 286/14 is also powered by an Intel 80286 CPU, but operates at 14 MHz (with zero wait states) for even faster performance. It, too, comes equipped with 1024KB memory, 1.2MB floppy disk drive, serial/parallel/game ports and a 101-key keyboard. No doubt about it — it's a hot machine and a dream to fly!

FIVESTAR 386's. **Don't forget to fasten your seat belt.**

The incredible speed and power of FIVESTAR 386's have made them a leading choice of corporations across America for multitasking and sophisticated applications, including CAD. In fact, there's so much performance and value built into our 386's, it can take your breath away.

The 386/16 is fast. Very fast. That's because it features an Intel 80386 CPU operating at 16 MHz, with zero wait states.

And its 1024KB memory and 1.2MB floppy disk drive will keep you airborne for long distances. Serial/parallel/game ports and a smooth performing 101-key keyboard are standard equipment.

Prices:

**The 286/10 –
from \$1099.**

**The 286/14 –
from \$1499.**



The 386/20. It's made for those who want to fly to the outer limits. With an Intel 80386 micro-processor operating at 20 MHz (with zero wait states) it'll move through the most complex applications with astounding ease. And you won't have to worry about running low on memory either. It not only features 1024KB of RAM and a 1.2MB floppy disk drive, it also has a 64KB cache memory. Naturally, it comes equipped with serial/parallel/game ports and a 101-key keyboard, too.

Customize your FIVESTAR to meet your own specifications.

All FIVESTAR 286 and 386 Computers are available with hard drives, from 20 to 320 MB, as well as a choice of monochrome, EGA, VGA or super-high resolution paper-white monitors. Whatever the requirement, FIVESTAR can meet it.

Prices:

**The 386/16 -
from \$1999.**

**The 386/20 -
from \$2999.**

**Unmatched reliability.
Unbeatable ground
support.**

Because every FIVESTAR Computer is tested and certified to meet the highest standards of quality, you can count on years of

reliable performance.

Once you've purchased your FIVESTAR computer, you'll get all the support you'll need. Just call our highly-trained service department *toll-free*. Most difficulties can be resolved within minutes.

For companies with critical applications, a comprehensive on-site service contract is available for just \$99. In most cases, service calls are made within 24 hours.

**Order by phone today.
And move your company to higher
levels of performance.**

To order a FIVESTAR 286 or 386 Computer, or for more information about our full line of high-powered computers, call us TOLL FREE. We'll have your hot new corporate jet parked in your hanger in no time!

1-800-752-5555

FIVESTAR
COMPUTERS

Circle 129 on Reader Service Card

America's hottest new corporate jets.

COMDEX/Fall '88 West Hall W848

FIVESTAR and Intel are registered trademarks.

All prices and specifications are subject to change without notice.

1311008

Evolution Comes to Accounting

State of the Art calls the latest incarnation of its Master Accounting Series M·A·S 90 Evolution/2. With that imposing moniker, the company claims it's designed to take full advantage of 80286- and 80386-based computers as well as multiuser operating systems.

Evolution/2 has over 100 new features, including an integrated menu system with pull-down windows for instant navigation through the various accounting applications. The program also has high-level password security.

Modules available in the M·A·S 90 Evolution/2 series include general ledger, accounts receivable, accounts payable, payroll, inventory management, sales order processing, purchase order processing, and job cost. **Price:** \$195 to \$995 per module.

Contact: State of the Art, Inc., 3545 Howard Way, Costa Mesa, CA 92626, (714) 850-0111.

Inquiry 787.

PERIOD	LINE	ACCOUNT NO.	DESCRIPTION	BALANCE
1 JAN 31	2	101-01-00	Cash on hand	
2 FEB 29	3	101-02-00	Cash in bank - Reg. checking	
3 MAR 31	4	101-03-00	Cash in bank - payroll	
4 APR 30	5	105-00-01	Cash in bank - savings	
5 MAY 31	6	105-00-02	Accts. receiv. - East Warehouse	
6 JUN 30	7	110-01-00	Accts. receiv. - West Warehouse	
7 JUL 31	8	115-00-01	Note receivable	
8 AUG 31	9	115-00-02	Inventory - East Warehouse	
9 SEP 30	10	115-00-03	Inventory - West Warehouse	
10 OCT 31	11	120-00-00	Inventory - Central Warehouse	
11 NOV 30	12	125-00-00	Prepaid insurance	
12 DEC 31	13	130-00-00	Prepaid advertising	
	14	150-00-00	Prepaid income taxes	
			Land	

Evolution/2 takes accounting software a step forward.

Project Management Takes to the Skyline

Most project management packages do only one thing: schedule projects. But Applitech Software has taken the process several steps further by combining project planning, outline processing, scheduling, and graphics into an integrated package.

The package is called Skyline, and although it runs on the IBM PC and compatibles, the company has included a

Macintosh-like graphical interface. Despite all its features, Skyline is still designed primarily for project planning.

Skyline also offers PERT charts, importing and exporting of generic subprojects, a variety of scheduling features, and Gantt charts. Besides a PC, you'll need a color or monochrome graphics adapter and at least 640K bytes of RAM.

Price: \$295. **Contact:** Applitech Software, Inc., 381 Harvard St., Cambridge, MA 02138, (617) 497-8268.

Inquiry 784.

Financial Planning for Business Owners

No, Ronstadt's Financials isn't a program for handling the cash flow of a famous singer. Lord Publishing says it's designed to help all you business owners take control of financial decision making. According to the company, it answers five "critical questions of entrepreneurial finance," namely: How much money does your business need? When does it need the money? What type of money (debt or equity) is needed? Where should you get the money? What value does this money have to you in terms of equity sold?

Ronstadt's Financials offers built-in accounting and financial expertise for a variety of specific industries, including real estate, retail, manufacturing, professional services, wholesale distribution, and contract services. These features tailor the program to your specific business.

The program also has knowledge bases with built-in formulas. You input figures only once and Ronstadt's Financials produces detailed budgets, break-evens, profitability measures, projected cash flows,

income statements, balance sheets, and worst-case/best-case scenarios.

The program works with the IBM PC, XT, AT, PS/2s, and compatibles and requires 640K bytes of RAM and a hard disk drive. A color monitor is recommended. Also included is the book *Entrepreneurial Finance: Taking Control of Your Financial Decision Making*.

Price: \$499. **Contact:** Lord Publishing, Inc., One Apple Hill, Natick, MA 01760, (617) 651-9955.

Inquiry 788.

A Duo for Manipulating Mail

Whether you handle small mailings for a local users group or five-figure mailings for a corporation, Phoenix Phive's aptly named Mail is a low-cost package designed to add some organization to your organization.

Mail is a general-purpose address manager that handles up to 30,000 names that the fleet-fingered can enter directly or import from ASCII or dBASE files. The package also exports its data in ASCII format.

Price: \$45.

Contact: Phoenix Phive Software Corp., 7830 East Gelding Dr., Suite 400, Scottsdale, AZ 85260, (602) 483-0991.

Inquiry 785.

And while we're on the subject of mailings, Paul Mace Software has brought its venerable NVELOPE program to the world of the Mac.

NVELOPE, which had been previously available in an MS-DOS version, is designed for those of us who have to abandon the computer and ferret out a typewriter every time we want to address an envelope.

NVELOPE is a desk accessory that uses the Mac's familiar graphical interface to grab addresses from a word processing document or its own address list. It can even add a return address or (if necessary) look up the ZIP code. NVELOPE works with all versions of the Mac.

Price: One 800K-byte disk, \$69; two 400K-byte disks, \$74.

Contact: Paul Mace Software, 400 Williamson Way, Ashland, OR 97520, (503) 488-2322.

Inquiry 786.

continued

"TOPSPEED EARNS A STANDING OVATION!"

—Kent Porter, Dr. Dobbs Journal

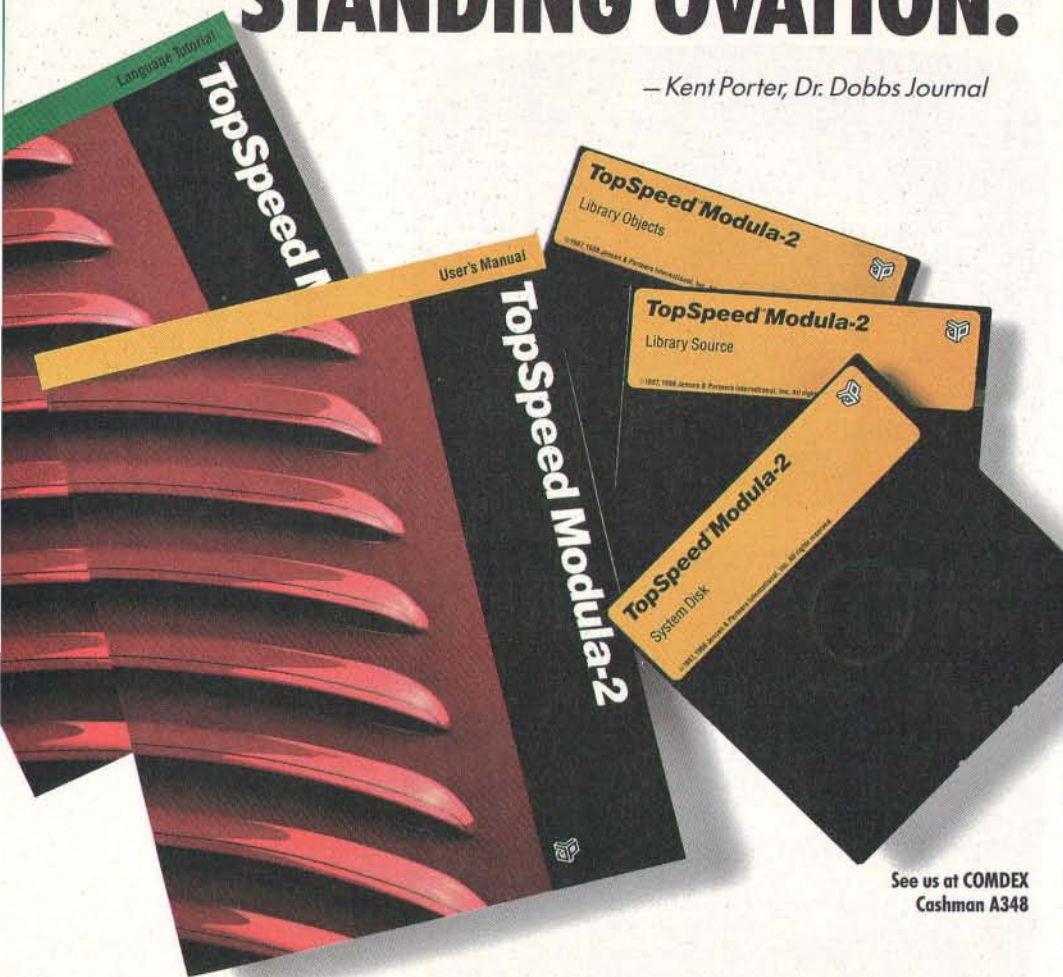

See us at COMDEX
Cashman A348

"...TopSpeed is surely one of the finest new products introduced to date in the PC arena...DDJ doesn't give unqualified raves very often, but there's no question about it in this case; JPI's TopSpeed Modula-2 is first-rate."

Kent Porter
Dr. Dobbs Journal

"JPI Modula-2 looks like another classic in the making. It generates code as good as or better than leading C compilers and the programming environment is a genuine pleasure to use."

Dick Pountain
BYTE Magazine

"I liked all of the hard-disk space that was recovered after I deleted my BORLAND, MICROSOFT, and LOGITECH compilers, because with TopSpeed Modula-2 all the rest are obsolete."

Robert D. Randall
Donnelley Marketing

The successor of Pascal: JPI TopSpeed™ Modula-2 produces better code than Microsoft C, Turbo C, Logitech Modula-2 and Turbo Pascal 4.0.

Introducing VID: The easy-to-use, source-level debugger. Single-step and trace through source in multiple modules. Examine and modify all variables in symbolic form, including arrays, records, enumerated types and pointers. Point and shoot breakpoints including "One-shot," "Sticky," "Delayed," and "Monitor." Watch both variables and Modula-2 expressions during execution. Automatic variable trace of all variables accessed, and assembler, registers and procedure call-stack trace windows. Package includes symbolic dis-assembler and execution profiler. 72-page manual.

The Compiler Kit includes: High-speed optimizing compiler (3,000-5,000 lines/min. on a PC AT 8MHz), integrated menu-driven environment with multi-window/multi-file editor, automatic make, fast smart linker. All Modula-2 sources to libraries included. BONUS: Complete high-speed window management module included with source. 258-page User's Manual and 190-page Language Tutorial.

The TechKit™ includes: Assembler source for start-up code and run-time library, JPI TopSpeed Assembler (30,000 lines/min.), TSR module, communications driver, PROM locator, dynamic overlays, and technical information. 72-page manual.

System Requirements: IBM PC or compatible, 384K available RAM, two floppy drives (hard disk recommended).

In England and Europe contact:
Jensen & Partners UK Ltd., 63 Clerkenwell Road, London EC1M 5NP. Phone: (01)253-4333.
Compiler Kit: £59.95, TechKit £34.95, VID £34.95, 3-Pack £109.95.
Handling charges:
In UK, add £2 for each product ordered. VAT will be added on software. In Europe, add £4 for up to 3 products, £2 for each add'l product.

Circle 173 on Reader Service Card



See our OS/2 version at COMDEX.



VID (Visual Interactive Debugger): power without complexity.

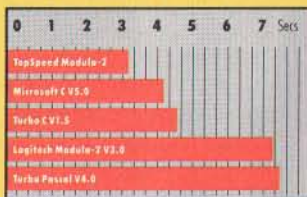

Sieve benchmark measured by the British Standards Institution (BSI)—25 iterations on an 8MHz AT.

Compiler Kit \$99.95
TechKit \$59.95
VID \$59.95

3-Pack \$179.95
(Compiler, TechKit & VID)

To Order:
In the US, call:
1-800-543-5202
In Canada, call:
1-800-543-8452

Or mail us your order with a check, money order, or VISA/MC information. 30-day unconditional money-back guarantee.

Shipping & handling charges:
In North America: add \$5, plus \$2 for each add'l product. CA residents please add applicable sales tax. Overseas: add \$20, plus \$8 for each add'l product.



Jensen & Partners
International

1101 San Antonio Rd.
Suite 301
Mountain View, CA 94043
Phone: (415)967-3200

TopSpeed and TechKit are trademarks of Jensen & Partners International. Other brand and product names are trademarks or registered trademarks of their respective holders.

Emulate the VT-240 on Your EGA

If you need to connect your PC to your corporate computer, chances are you'll need to emulate a DEC VT-240 terminal to get the most out of the connection. PolyStar can give you full VT-240 or VT-241 emulation on any EGA-equipped PC.

The standard VT-240 provides 800- by 240-pixel resolution, while a standard EGA provides only 640 by 350 pixels. But Polygon says it's invented a way to coax the EGA into giving 800- by 350-pixel resolution, giving you a full graphics image or a 132-column display. PolyStar also includes a utility for remapping a standard keyboard. You can map multiple characters onto a single key, making it a custom function key. You can also use the program with DEC's LK250 keyboard, as well as remap the LK250 for regular PC use.

Price: \$299; EGA option, \$29.

Contact: Polygon, Inc., 1024 Executive Pkwy., St. Louis, MO 63141, (314) 576-7709.

Inquiry 792.

WordPerfect Makes the Network

If you're a confirmed WordPerfect 5.0 user and have a PC-based network, you can bring the two together with a network version of WordPerfect 5.0, now available from the Utah-based word processing mavens.

The network version of WordPerfect 5.0 runs on the 3Com 3+ network, 10Net, AT&T StarLAN, Banyan, IBM Networks, Novell NetWare (versions 4.6 and higher) or Advanced NetWare, TOPS, Torus Tapestry, Western Digi-

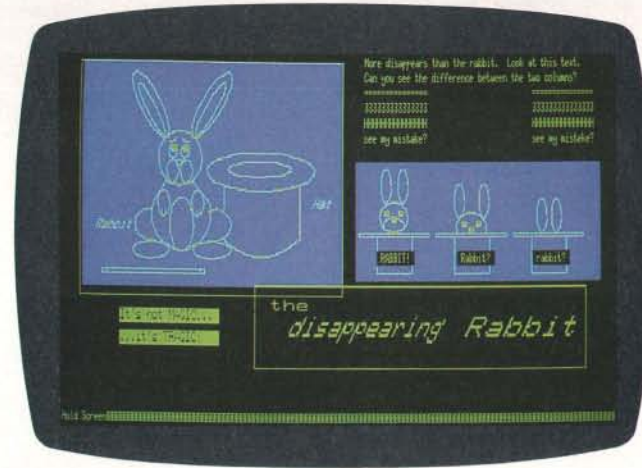
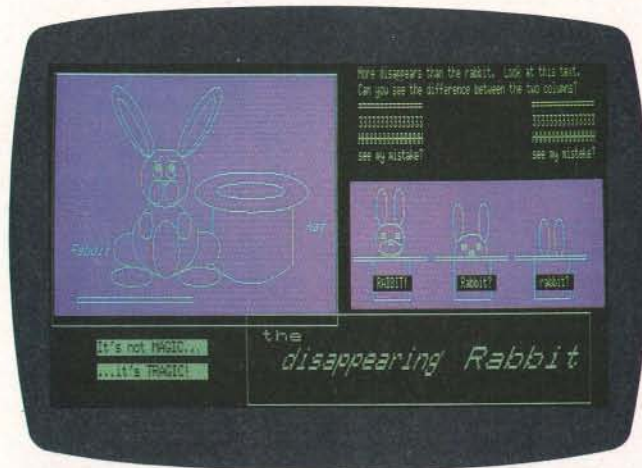

A VT-240 screen, and Poly-Star's EGA emulation of the VT-240.

tal ViaNet, and most other network systems that support DOS file locking. For European users, it also runs on NOKIA PC-Net.

Each networking workstation using WordPerfect 5.0 requires 384K bytes of RAM and MS-DOS 2.0 or higher. If you want to use the document-locking feature, you'll need MS-DOS 3.0 or higher.

Price: File server fee, \$695; each additional workstation, \$150; update from non-network version, \$120.

Contact: WordPerfect Corp., 288 West Center St., Orem, UT 84057, (801) 225-5000.

Inquiry 790.

Mail-Server Links Remote Locations

Mail-Server is a software package that combines communications functions with electronic mail features. It's a memory-resident program that runs in the background and offers remote-access capabilities. The package is fully automatic. You can send or receive messages or attached files from any attended or unattended IBM PC or compatible, 24 hours a day.

Mail-Server has an auto-script capability that lets you record file-transfer procedures. Then you can automatically send files at daily, pre-scheduled times. When you

place a Mail-Server call, a window pops up on the receiving system, on top of the running application.

The Mail-Server distribution list can send E-mail to multiple mailboxes and up to 100 locations. You can also attach any number of files to a message. Other Mail-Server features include a built-in text editor and a terminal-emulation utility that emulates most asynchronous terminals. The package uses its own file-transfer protocol.

To use Mail-Server, you'll need an IBM PC, XT, AT, PS/2, or compatible and at least 384K bytes of free RAM.

Price: \$195 per station.
Contact: 3X USA, One Executive Dr., Fort Lee, NJ 07024, (800) 327-9712; in New Jersey, (201) 592-6874.
Inquiry 791.

Communicate via OS/2

LogiCOMM is a general-purpose communications package designed to take advantage of OS/2's multitasking capabilities, allowing you to perform background communications and file transfers.

With the package, you can do both foreground and background data transfers with XMODEM, XMODEM 1K, YMODEM batch, YMODEM G, CompuServe Quick B, and ASCII upload/download protocols.

LogiCOMM requires an 80286- or 80386-based computer running OS/2 and supports both Hayes-compatible and other modems.

Price: \$30.
Contact: Logistique LMM, 1550 Barre St., St. Laurent, PQ, Canada H4L 4M6, (514) 748-9192.

Inquiry 793.

continued

ONCE IN A BLUE MOON...COMES A STROKE OF GENIUS.

SCANMAN™ HANDHELD SCANNING FOR \$299.

Pop any image up to 4" x 11" straight into your PC. Clip it, crop it. Resize and rotate it. Merge, save, and store it.

Choose between high contrast or high detail. Import images into any best selling publishing application—PageMaker™, Ventura™ and many more. All you need is \$299, an IBM PC, XT, AT or PS/2 (or compatible) with a spare slot, and five minutes to set up.



Choice of editing colors.

Scan directly into graphics editor for a full range of paint utilities.



Ideal 4" scanning window



TO ORDER—or for the name of your nearest dealer—CALL: 800-231-7717, IN CALIFORNIA CALL: 800-552-8885.

Or fill in the coupon:

BY

Name _____

Address _____

City/State/Zip _____

Phone _____

Send to: LOGITECH, 6505 Kaiser Drive, Fremont, CA 94555

© 1988 Logitech. PageMaker and Ventura are trademarks of Aldus and Ventura Software, respectively.

ScanMan™
The Hand-Held Scanner.



LOGITECH

Personal Peripherals. Worldwide.
Circle 195 on Reader Service Card (DEALERS: 196)

Professional Graphics Meet the Mac

The venerable Apple Macintosh—helped along by an enthusiastic coterie of third-party developers—is butting its way into more and more “professional” applications.

Case in point: The Avalon Development Group has unveiled a product for professional graphics designers called PhotoMac. It's an integrated graphics prepress application that lets you manipulate the Mac II's 24-bit color images, enhance them, and combine them with text from any of the popular page-layout programs to produce color publications.

PhotoMac lets you redesign, retouch, and color-correct images. You can then print color proofs, generate four-color separations, or combine images with text. The company claims you need only 2 megabytes of RAM to handle full-color full-page graphics. Using conventional techniques, you'd need about 25 megabytes of RAM.

Price: \$695.

Contact: Data Translation, Inc., 100 Locke Dr., Marlborough, MA 01752, (800) 522-0265.

Inquiry 798.



PhotoMac lets you manipulate digitized photos.

Coming Soon to the Graphics Screen

Are you often the victim of one of life's greatest disappointments—namely, laser printer output that doesn't look anything at all like you thought it would? A company named Data Perceptions has a simple answer to the problem. The company's Laser Preview is a memory-resident printer utility program that redirects printer output to a full-page on-screen preview. So what you end up with is a true WYSIWYG screen image of the laser printer output.

Laser Preview can display the document page image faster than the printer, allowing you to check the page for-

mat and text before committing it to the printer.

The program takes up about 64K bytes of RAM and works with the IBM PC, XT, AT, PS/2s, or compatibles. You'll also need a CGA, EGA, VGA, Hercules, or compatible graphics card and monitor.

Price: \$69.95.

Contact: Data Perceptions Corp., 9842 Hibert St., Suite 137, San Diego, CA 92131, (619) 455-9500.

Inquiry 796.

Speaking of printers, if you own a Hewlett-Packard DeskJet ink-jet printer and feel more than a little constrained by its limited selection of low-cost fonts, there's SoftFontWare's LaserJet-to-DeskJet font conversion package.

As its name implies, the package will happily convert any soft font designed for the LaserJet to work on the DeskJet. There are hundreds of widely available public domain and shareware fonts available from bulletin boards.

Besides the actual conversion program, the disk you'll receive also contains a program that corrects common errors found in public domain LaserJet soft fonts, a program to print character-width tables for any DeskJet soft font, and a program to display magnified DeskJet font characters on any EGA display.

Price: \$42.

Contact: S.H. Moody & Associates, Inc., SoftFontWare, 1810 Fair Oaks Ave., South Pasadena, CA 91030, (818) 441-2260.

Inquiry 797.

Take My Computer... Please

On the lighter side, Responsive Software of California says it's bringing high technology to the (kind of) serious business of creating jokes. But seriously, folks, the Humor Processor is designed for speech writers, columnists, executives, or anyone who needs to say something funny.

The company says the Humor Processor is more than just a database of jokes. You can choose a joke formula, type in the joke's setup, and then enter the program's brainstorming mode to come up with joke ideas.

It runs on any IBM PC or compatible, with or without a rodent, and it needs 320K bytes of RAM.

Price: \$49.95.

Contact: Responsive Software, 1901 Tunnel Rd., Berkeley, CA 94705, (415) 843-1034.

Inquiry 802.

Let's Think About It

A company called Transpower says that its program—called Expert Thinker—is the first expert system designed to bring logical-reasoning capabilities to microcomputers. Expert Thinker is a theorem prover that doesn't use old standard heuristic algorithms to find solutions.

The program is written in Prolog, but unlike Prolog, it

features true negation, non-Horn clauses, occurs check, staged depth-first search, and Meson reduction and extension operations. According to the company, Expert Thinker is designed for logicians, mathematicians, scientists, engineers, artificial-intelligence gurus, philosophers, college professors and students, and even puzzle lovers.

You can add logical reasoning powers to your IBM PC, XT, AT, PS/2, or compatible. You'll also need 640K bytes of RAM. Expert Thinker comes with a 30-day money-back guarantee.

Price: \$149.

Contact: Transpower Corp., 1 Oak Dr., Parkerford, PA 19457, (215) 495-6362.

Inquiry 799.

INTERNATIONAL

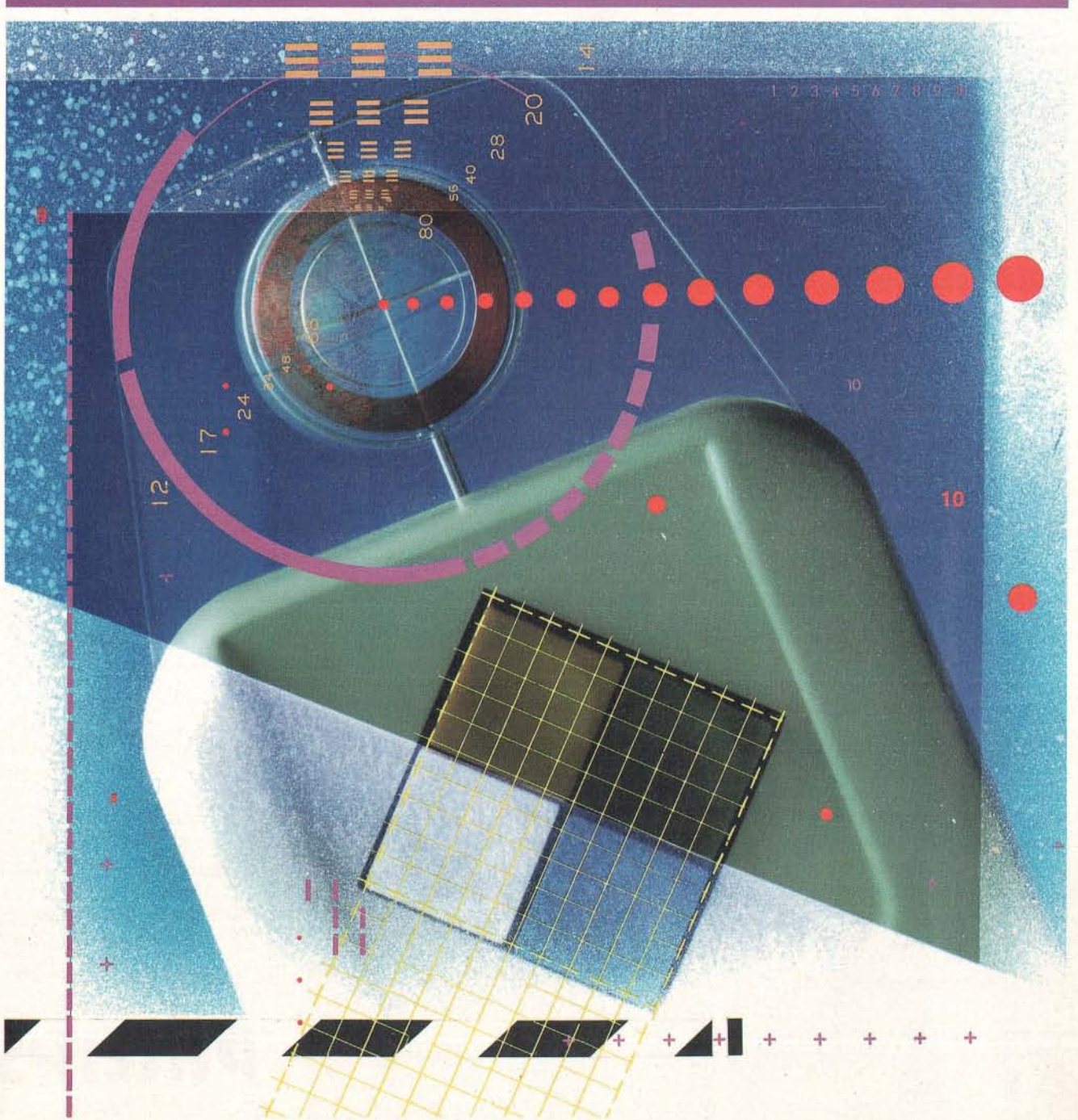



TWO WAYS TO MAKE THE MOST OF VGA.

- ▶ With its VGA standard, the IBM PS/2 has introduced a new generation of brilliant displays. But since VGA uses a different frequency, a special monitor is needed. That's why Philips has designed two new Pro Monitors that bring out the best in VGA.
- ▶ With a VGA Pro Monitor and a VGA graphics board, you can instantly upgrade an IBM PC or compatible to VGA. And you'll still be able to run all your existing software – whether it's MDA, Hercules, CGA or EGA.
- ▶ Our VGA colour Pro Monitor offers crisp, vivid graphics at an optimal resolution. They incorporate Philips' most sophisticated tube technology, with special ergonomic features such as glare reduction and increased image contrast.
- ▶ And our monochrome VGA compatible is no less remarkable. Its flatsquare screen eliminates distortion, and offers maximum greyscales in paperwhite phosphor. Combined with anti-glare features this ensures hours of comfortable use.
- ▶ Like all Pro Monitors, our VGA-compatible models are guaranteed for two years after the purchase date*. And you can count on our extensive network of local service centers.
- ▶ So why not start enjoying VGA today? With a VGA Pro Monitor from Philips.
- ▶ For more information, please write to Philips International B.V., SFF-836, 5600 MD Eindhoven, the Netherlands, or visit your nearest dealer.

IBM, PC, XT and AT are registered trademarks and PS/2 is a trademark of International Business Machines, Inc. *Details of the warranty differ per country.



BYTE editors offer hands-on views of new products

Map Out Road Trips Through England, Scotland, and Wales

Autoroute 1.1 helps you plan road journeys between towns in England, Scotland, and Wales. You enter your starting point and destination, and the program finds the shortest, quickest, or cheapest route, or all three, if requested. It presents the route as an itinerary of road names and turnoff instructions, and as a road map if you have a graphics adapter. You can use Autoroute quite effectively without graphics, but for many people the fun lies in the maps. The program also lets you print a hard copy of the itinerary and the road map.

Based on the Ordnance Survey maps of the British Isles, Autoroute comes with a database of 67,000 miles of roads and 6000 towns and villages, which fills three standard 360K-byte floppy disks and occupies almost 300K bytes of disk space. The program has a copy-protection scheme that lets you install it once onto a hard disk and, to forestall objections to such schemes, NextBase also supplies a second copy of the key disk. It's possible, but somewhat inconvenient, to run Autoroute from a floppy disk drive, so I strongly recommend a hard disk drive.

To use graphics, you have to install the MetaWINDOWS graphics driver program before running Autoroute, which is done via a batch file. A configuration utility helps MetaWINDOWS detect which graphics card and mouse you are using; in my case, it correctly identified Hercules (Autoroute does not support Hercules Ramfont modes).

The user interface is a Lotus 1-2-3-style horizontal menu that contains the main activi-

ties: Journey, Options, Speeds, Calculate, Map, and Table. When you select Journey, the program displays a screen in which you type the name of the town you are leaving from, your departure time, and your destination. You can also enter a list of places you wish to visit on the way, how long you will stay in each, and a list of places you wish to avoid.

I discovered that Autoroute can handle minor spelling errors and obvious abbreviations. For example, if Autoroute doesn't recognize the name of a town you type in, it puts up a window containing the names of towns that most closely match.

With the Options menu, you enter your preference for motorways, A and B roads, and whether you dislike frequent route changes.

Speeds lets you enter the typical speeds your vehicle can sustain on town and country roads; it's from these figures that Autoroute computes journey times.

When you select Calculate, Autoroute computes the route or routes. On my 4.77-MHz IBM PC, it took 6 minutes for Autoroute to find three alter-

native routes from London to the Lake District via Chesterfield.

When the program finishes the calculations, you select Map to view the road map, or Table to see the detailed list of roads and turnoffs. On a color monitor, the program uses colors to indicate the different kinds of roads, while on a monochrome display, the program uses a blinking effect to draw your attention to the selected route.

You can point to details on the map with a mouse or cursor keys, and Autoroute will try to tell you the name of the town or the road at which you're pointing. You can also pan in all four directions and zoom in or out on an area, although zooming reveals very little extra detail because the database only contains major roads and towns and no information at street or building level. You can print the map on an IBM- or Epson-compatible graphics printer using the included memory-resident screen dump driver.

The Table menu displays a detailed itinerary with every road and turn you must take, the time you should arrive there, the name of the most

likely signposted town, the distance you will travel on this road, and its rough compass bearing. You can move a highlighted cursor bar down the list, and it will display the time and distance from the point of departure to this stage of your journey. You can print out the list or save it in a print file; the hard copy makes an ideal reference guide and is easier to read on the move than a map.

So just how useful is Autoroute? If you just need to know how to get from point A to point B, then looking at a map will usually be quicker than using Autoroute, assuming you know how to read one and have an idea where point B is. Where Autoroute scores heavily is in distinguishing between the quickest, shortest, and cheapest routes. Even though it has to make some fairly crude assumptions (e.g., about fuel consumption versus speed), it will be far better than you at estimating journey time and distance; after all, adding up the incremental times over a journey is precisely what computers are good at.

Given the size of the task, Autoroute's performance is excellent, though it's a lot nicer to use on an 80386-based machine than on an 8088. NextBase's stated policy is to upgrade Autoroute annually (for a fee of £30), and as IBM PCs get faster and disks get bigger, the company will most likely incorporate more detail from the Ordnance Survey. The program's biggest limitation is the lack of street map information to get you into and across cities. Nevertheless, for people who travel a lot, Autoroute is well worth a try and is reasonably priced.

—Dick Pountain

THE FACTS

Autoroute 1.1
£135

Requirements:

IBM PC, XT, AT, or compatible with 512K bytes of memory and two floppy disk drives, or one floppy disk drive and one hard disk drive. To view maps, you must have a graphics adapter; all the IBM adapters and others

from Hercules, Everex, WYSE, Tecmar, and more are supported. A Microsoft or Mouse Systems mouse is optional.

NextBase Ltd.
March House
Churt Rd.
Hindhead, Surrey
GU26 6BR, U.K.
(0372) 69011
Inquiry 830.

WHAT'S NEW

INTERNATIONAL

Intelligent I/O Boards for the IBM PC and PS/2s

Tamarisk offers the IntelliPort PS8, AT4, AT8, and AT16 intelligent I/O boards. The PS8 is an 8-port board that supports the Micro Channel architecture of the IBM PS/2 Models 50, 60, and 80. The AT4, AT8, and AT16 boards are 4-, 8-, and 16-port versions that provide high-speed RS-232C serial communications for terminals, printers, modems, and other peripherals running on the IBM PC AT, the Compaq 386, and compatibles. You can add up to four boards per host machine.

In addition to set data transfer rates from 50 to 38,400 bits per second, the IntelliPort boards provide user-programmable custom data transfer rates. You can transfer data at 16 bits to and from the host AT, and choose from six interrupts or polled operation. Each channel supports four general-purpose data set signals.

Each of the IntelliPort boards incorporates IntelliPrint, a transparent print facility that brings flexibility to 80286, 80386, and IBM PS/2 machines, and IntelliView, which gives you virtual terminal support and a multiple session ability. When you use IntelliPrint with a 2-port terminal, it lets you operate a printer and a terminal simultaneously, using the same port and cable, while each retains its identity as a separate system device. An IntelliKey feature provides up to 16 user-defined keys.

The IntelliPort PS8, AT4, AT8, and AT16 boards are provided with a choice of software drivers for SCO Xenix V, 80286, 80386, and VP/ix. **Price:** £895 for the IntelliPort PS8; £545 for the IntelliPort AT4; £745 for the Intel-



The IntelliPort AT8 is an eight-port I/O board.

liPort AT8; £1345 for the IntelliPort AT16.

Contact: Tamarisk, Foundation House, Norreys Dr., Maidenhead, Berkshire SL6 4BX, U.K., (0628) 770911. **Inquiry 871.**

Use Lotus 1-2-3 for Financial Forecasting

With @RISK (pronounced "at risk"), you can investigate the effect of uncertain data on your Lotus 1-2-3 spreadsheet. The program is designed primarily for financial forecasting, investment appraisal, and market planning applications.

For each key variable in a model, @RISK lets you enter a range of possible values. For example, instead of entering 300, you might enter @Nor-

mal (300,30), which indicates that the value might be anything between 270 and 330. When @RISK recalculates the model, it produces a graph showing the possible answers.

You can use any one of 18 statistical distribution functions to let @RISK perform its simulations, including uniform, normal, and exponential. It also performs random samplings by Latin Hypercube or Monte Carlo methods.

The @RISK add-on for Lotus 1-2-3 runs under DOS 2.0 or higher on the IBM PC, XT, AT, and compatibles with 512K bytes of memory and Lotus 1-2-3 version 2.0 or higher.

Price: £325.

Contact: 4-5-6 World, Wellington House, Butt Rd., Colchester, Essex CO3 3DA, U.K., (0206) 579776.

Inquiry 832.

If you would like your new product considered for publication in the international section of BYTE, send press releases to BYTE, Attention: Martha Hicks, One Phoenix Mill Lane, Peterborough, NH 03458, U.S.A.; or Dick Pountain, BYTE, McGraw-Hill Publishing Co., 34 Dover St., London W1X 3RA, U.K.; or Shouzou Watanabe, Editor in Chief, Nikkei BYTE, 1-1, Kanda-Ogawamachi, Chiyoda-ku, Tokyo 101, Japan. All press releases must contain price information, address, and telephone number.

Detect Infestation by Virus Programs

You can use the CHKVIRUS program to search your disks for evidence of virus programs. CHKVIRUS neither cures nor prevents virus attacks, but it alerts you to the fact that your disk has become infected.

The first run of CHKVIRUS produces a fingerprint of the vulnerable files on your disk, as well as other vulnerable disk areas, such as the boot sector. You then store the write-protected fingerprint on a clean disk. After the initial run, you can use CHKVIRUS as often as you feel necessary. The program detects infestation by virus programs by comparing the disk with the fingerprint; the action of a virus installing itself changes the fingerprint. You can then take curative measures by restoring older versions of files, formatting disks, or using other commercial or public domain anti-virus programs.

CHKVIRUS runs under DOS or OS/2 and requires at least 128K bytes of memory. It comes with documentation describing current virus programs affecting the IBM PC, XT, AT, and compatibles; how to recognize them; and how to eradicate them. S & S offers support and consultancy on a daily rate basis and also offers CHKVIRUS free of charge to sites that have already been affected by a virus. **Price:** £5 or \$10 U.S., with documentation but without technical support.

Contact: S & S Enterprises Ltd., Weylands Court, Water Meadow, Germain St., Chesham, Buckinghamshire HP5 1LP, U.K., (0494) 791900.

Inquiry 827.

continued

We'll Give You Six Solid Reasons Why You Should Be Developing Your Applications In Clarion.



All New Version 2.0

The Clarion Professional Developer Is A Total Programming Environment That Runs On Any IBM PC, PS/2, Or True Compatible With 384K Of Memory And A Hard Disk. The Retail Price Is Just \$695. NOT Copy Protected.

CLARION

PROFESSIONAL DEVELOPER™

1 Slash Your Total Development Effort... From Prototyping To Completion

You'll get live results fast—even before you write the first line of code. Ideas become running applications in a few hours.

Designer, the front-end application generator, allows you to produce major programs with *no coding*. It eliminates prototyping as a preliminary step because design and source code generation are done concurrently. You can implement a dazzling color screen or a report in minutes. You'll probably never code a screen again!

2 Automatically Generate Commented Source Code For Your Entire Application

The Professional Developer's **Designer** is the most powerful application generator in the industry. It creates structured source code that is fully commented. You can easily add to it, modify it, or just admire it.

And The Professional Developer is a complete development environment with all the tools that you need.

3 Create High-Speed, Bullet-Proof Data Management With Built-In LAN Support

Advanced techniques allow you to tune your data management to fit each application. Use related files, data encryption, memo fields, automatic recovery, and commit and rollback—all without compromising Clarion's high level of performance. And complete LAN features are included so the applications you develop will run on your network without any additional run-time or LAN PACK cost.

4 Interface To Your Own C or Assembler Routines For Special Requirements

The Professional Developer will support special device routines and complex logic written in C and Assembler. You won't have to completely re-write all those existing procedures. You can produce completely open-ended solutions that can grow with your needs or requirements.

5 Produce Executable Programs That Don't Need Run-Time Systems

Compile your application into an .EXE program that will run on a stand-alone computer or workstation so you can distribute your programs without costly run-time systems.

6 Get Started Immediately. You'll Be Productive The First Day.

Although there's a lot of horsepower "under the hood," you'll be producing programs soon after you open the package. You'll find the whole environment friendly and comfortable. PC Week says: "Clarion is easy to learn and easy to use."

InfoWorld Gives You One More.

After an exhaustive evaluation of twenty relational databases, InfoWorld proclaimed Clarion's top-scoring Professional Developer "... the system of choice for the serious applications programmer." Perhaps the most compelling reason of all for developing your applications in Clarion. To get started doing just that, see your Clarion dealer, or call our toll-free number, today.

(800) 354-5444

Ask for a free copy of our tutorial diskette and introductory material.



HIGHEST
RATED
RELATIONAL
DATABASE

A Multiplexer for ISDN

Mayze Systems' Arrow 640 is a high-speed time-division multiplexer designed for Integrated Services Digital Network (ISDN) and other digital services up to 64 kilobits per second. The multiplexer lets you combine data channels, or six data channels and one voice channel, into a single digital link.

You can select from four configurations, which you can enter, store, and recall at any time using the front-panel buttons and the liquid crystal display module or using a separate terminal attached to the supervisor port. To ensure security, you can disable the buttons and protect the port password. Modem support of the supervisor port permits remote control over the telephone network. An available option automatically loads different configurations at certain times of the day to suit the varying demands of the digital link.

The data channels can be asynchronous or synchronous at speeds between 1200 and 19,200 bits per second; you can clock synchronous channels internally or externally. Modem control signals support various applications, including multidrop and switched network channel extensions.

You can connect the multiplexer to personal computers, minicomputers, and mainframes via the data port. **Price:** £950 for four channels; £1250 for eight channels; £1450 for six data channels and one voice channel. **Contact:** Mayze Systems Ltd., Delta 900, Great Western Way, Swindon, Wiltshire SN5 7XQ, U.K., (0793) 511789. **Inquiry 868.**



The Arrow 640 lets you select from four configurations.

A Luggable Music Sequencer

The Portable Professional Sequencing System (PPSS) is a compact, luggable system that combines the power of an IBM PC XT with the Roland MPU-401 musical instrument digital interface (MIDI).

The supertwist LCD screen has adjustable view angle and contrast control with a resolution of 640 by 200 pixels. You can configure the video adapter to emulate an MDA or a CGA, and to drive a standard IBM-compatible monitor. The active display is software-selectable.

You can display and edit sequences, as well as filter and edit MIDI notes and events with Voyetra, the supplied sequence software. Voyetra gives you 16, 32, or 64 tracks; music manipulation tools such as 17 transform commands, and harmonic display and entry of transpositions; a built-in MIDI network organizer; and a universal program bank transmitter. Memory buffers give you cut-and-paste operations, punch-ins, time-resolution of 192 pulses per quarter note, and the ability to synchronize to tape. The sequencers also have compatible data formats that let you upgrade as required, without

losing previous work.

The PPSS is compatible with the IBM PC and comes supplied with MS-DOS 3.2. Other features include an 8088-2 CPU running at 4.77 or 8 MHz, provision for an 8087 coprocessor, 640K bytes of RAM, three IBM-compatible expansion slots (two full-size and one half-size); and one 360K-byte 5¼-inch floppy disk drive. Available options include a 20-megabyte hard disk drive, a second 5¼- or 3½-inch floppy disk drive, an internal modem, and an external monitor.

Price: £1520 and up, depending on the configuration. **Contact:** Poke Ltd., 54 Cambridge Rd., St. Albans, Hertfordshire AL1 5LD, U.K., (0727) 51692. **Inquiry 850.**

A Hand-Held Optical Character Reader

RAFI offers DataSweep 1/Lesemaus, a hand-held optical character reader for selective data entry (see What's New, page 70, in the June BYTE). You sweep the reader across lines of text,

and the data automatically enters into your personal computer. You can also enter characters directly into most word processing, spreadsheet, database, and desktop publishing application programs. The company is currently modifying the product to read the German character set, and the company will further enhance it so it will be able to read a variety of other international characters.

The DataSweep 1/Lesemaus package includes the hand-held character reader, an interface board that requires a full-size slot in an IBM PC, XT, AT, or compatible, and software that runs under DOS 2.1 or higher. **Price:** 2500 deutsche marks. **Contact:** RAFI GmbH & Co. Elektrotechnische Spezialfabrik, Postfach 2060, D-7980 Ravensburg 1, West Germany, 0751-89-302. **Inquiry 851.**

Preprocessor Makes C Language Like Smalltalk-80

The C_{talk} preprocessor supports Smalltalk-80-type programming in the C language on the IBM PC AT and compatibles. Similar products already available include C++, but C_{talk} is similar to Smalltalk-80 in that it has a parent class, defines called functions at execution, and offers an editor called a "browser." It does not offer a compile/debug function, but it supports Microsoft C, Lattice C, Turbo C, and C86. System One plans to port it to the NEC PC-9801, but the date has not been announced. **Price:** 45,000 yen. **Contact:** System One Corp., Ohmori Building, 2-15-16 Nihonbashi, Ningyou-cho, Chuo-ku, Tokyo 103, Japan, (03) 663-4551. **Inquiry 848.**

continued

USA SOFTWARE IN EUROPE!

NO COSTLY PHONE AND FREIGHT CHARGES!

QUICK DELIVERY! LOW PRICES!

Come pay us a visit at our new address.
We carry over 1,200 products!
Call today for Price List.

386 PRODUCTS:	Price
PharLap 386\ASM/Link (Intel 80386 Development System) ...	\$ 699
ADVANTAGE 386 C (Protected mode C Compiler)	\$ 1079
High C/386 (Use full 32 bit power of 80386)	\$ 1437
Concurrent DOS 386 Prgrmr's Toolkit (By Digital Research) ..	\$ 209
ADVANTAGE 386 Pascal (Protected mode Pascal/386)	\$ 1079
FoxBASE+/386 (Run any dBASE III Plus program without modification) ..	\$ 565
Microsoft Windows/386 (Multiple applications environment)	\$ 231
Microport Sys. V/386 Complete (Runtime, Development System) ..	\$ 1191
NDP C-386 (Globally optimizing C Compiler. Mainframe quality code) ...	\$ 805
NDP Fortran-386 (Protected mode; recompiled 286 code-3-8 times faster)	\$ 805
OS/386 Software Dvlpr's Kit (Port exist. applic. to prot. mode) ...	\$ 649
Paradox 386 (Powerful, easy to use database)	\$ 990
Professional Pascal 386 (Handles large systems of modules) ..	\$ 1409
SCO XENIX Sys. V Comp. 386 (Op. Sys. Dvlp. Pak & Text Prep) ...	\$ 1919
Microport System V/386 Complete (Runtime, dvlpt. sys.) ...	\$ 1191
VM/386 (Control Program. Turns 386 machine into many)	\$ 299
ARTIFICIAL INTELLIGENCE:	
Arity Combo Pak (File interchange, compiler/interpreter)	\$ 1319
Golden Common Lisp (Training and Development System)	\$ 1005
MuLISP-87 Development System (Formerly Microsoft Lisp) ...	\$ 549
Turbo PROLOG (Complete A.I. environment)	\$ 169
Turbo PROLOG Toolbox (Over 8,000 lines of Turbo Prolog source) ...	\$ 115
Vp Expert (Complete Expert System Development Tool)	\$ 125
ASSEMBLERS LINKERS & TOOLS:	
ADVANTAGE Disassembler (Disassemble .EXE & .COM files) ...	\$ 315
Microsoft Macro Assembler (Fastest assembler dvlpt. sys.) ...	\$ 179
Plink 386+ (Overlay linkage editor)	\$ 453
Turbo Source (Create commented source code listings)	\$ 155
BASIC LANGUAGE & TOOLS:	
FINALLY! (BASIC Graphic subroutine library)	\$ 135
Microsoft Quick BASIC (With editor & debugger)	\$ 121
ProBas (232 BASIC routines)	\$ 163
Turbo BASIC (Editor, compiler & debugger)	\$ 115
BUSINESS GRAPHICS:	
Boeing Graph (3-D presentation graphics)	\$ 359
Dan Bricklin's Demo II (produce prog. prototypes, Demos & tutor) ...	\$ 265
Gem Collection (Produce documents w/ integrated text & graphics) ...	\$ 105
Pizzazz Plus (Full EGA support, 200 colours)	\$ 214
C LANGUAGE:	
High C (Protected mode, compiles across machines & op. sys.) ..	\$ 945
Instant C/16M (Protected mode. Up to 16MB)	\$ 1205
Microsoft C Compiler (Includes QuickC & CodeView)	\$ 527
Microsoft Quick C Compiler (Very fast C compiler) ...	\$ 121
Turbo C (Pull down menus with windows)	\$ 117
C LIBRARIES AND TOOLS:	
DBASE C Tools Prgrmr's Lib. (Built in C func. for dBASE III Plus) ..	\$ 101
C-Space (functions library for screen design & code generation) ..	\$ 395
C ASYNCH MANAGER (INTERpreter driven polling control)	\$ 157
C TOOLS PLUS (Full spectrum of general utility functions)	\$ 157
C Utility Library (Over 400 functions)	\$ 213
Greenleaf Communications Library (Asynch. comm. library)	\$ 227
Greenleaf Functions Library (300 functions with all DOS & BIOS) ..	\$ 247
Multi-C (Library for multi-tasking programs)	\$ 199
Turbo C TOOLS (Compiled C functions for Turbo C)	\$ 159
COMPUTER AIDED DESIGN:	
AutoCAD Release 9 (Most popular CAD package)	\$ 3995
AutoSketch Enhanced (Full-functions CAD for line art)	\$ 118
Design Cad 3-D (Export 3D drawing to 2D packages)	\$ 297
Generic Cadd (Mechanical drafting & design. 200 colors/line types) ..	\$ 105
COBOL LANGUAGE AND TOOLS:	
COBOL spII (Powerful screen management tool)	\$ 519
Level II COBOL (Combines best of mainframe & PC capabilities) ...	\$ 459
Microsoft COBOL Compiler (Move appl. from mainframes to PCs) ..	\$ 817
Realia COBOL (Compile lang. prog. from mainframe or micro Compiler) ..	\$ 1398
RM/COBOL 85 Development System (Fastest devel. system)	\$ 1555
Screenplay (Screen management)	\$ 249
CROSS DEVELOPMENT:	
Aztec C Cross Devel. System (DOS to many different targets)	\$ 1055
Lattice 68000 C Cross Compiler (PC host to 68k target)	\$ 605
Lattice Z-80 C Cross Compiler (PC host to Z-80 target)	\$ 605
QUELO 68000 Cross Asm/Link (PC host to 6k target)	\$ 779
DATABASE AND FILE MANAGEMENT:	
Btrieve (Keyed indexed file management system)	\$ 299
Xtrieve Report Option (Report writer)	\$ 193
Xtrieve (Menu driven Query system)	\$ 323
C-ISAM (C functions for indexed file system)	\$ 343
c-tree with r-tree (Btree file handler with report generator) ...	\$ 785
CLIPPER (Compiles dBASE into .EXE files)	\$ 723
d-tree (Comprehensive application generation modules)	\$ 599
dB/RA (Arrays/windows program)	\$ 285
dB_QUERY (Query for dB_Vista)	\$ 297
dB_VISTA (Build, maintain & access database files)	\$ 297
dB_C III Plus (ISAM package & C interface to dBASE III Plus) ..	\$ 845
dBFast (Turbo compiler for dBASE III Plus)	\$ 115
DBXL Diamond (Extended lang. features for dBASE III Plus) ..	\$ 209

Eagle-Emerald Bay (Advanced database progmg. language) ..	\$ 511
FoxBASE + (Run dBASE programs without modification)	\$ 373
Informix-4GL (4th generation application language)	\$ 1497
Informix-ESQL (Imbed SQL statements & incorporate into C Programs) ..	\$ 897
Informix-SQL (Relational DBMS)	\$ 1197
Knowledgeman/2 (Integrated system with menus & on-line help)	\$ 613
Magic PC (Eliminate coding, cut months of development time)	\$ 283
ORACLE 2.1 (Database add in for Lotus 1-2-3)	\$ 245
Paradox 2.1 (Powerful, easy to use database)	\$ 763
QUICKSILVER (dBASE III PLUS compiler)	\$ 620
R&R Clipper/Foxbase+ Module (Report writer)	\$ 65
R&R Relational Report Writer (Report writer for dBASE) ..	\$ 185
R:BASE for DOS (DBMS with high level programming language) ..	\$ 803
Tom Rettig's Adv. Prgrmr's Library (175 dBASE III + forms) ..	\$ 145
XQL (Relational DBMS for programmers)	\$ 959
Xtrieve (Menu driven Query system)	\$ 323
DEBUGGERS:	
Advanced Trace-86 (Symbolic debug & Asm. Interpreter)	\$ 233
Periscope I (With breakout switch & submarine board)	\$ 839
Periscope III 10MHz (w/ 512K write proms. RAM & breakout switch) ..	\$ 1679
DESKTOP PUBLISHING:	
Byline (Use with dBASE III Plus or Lotus 1-2-3)	\$ 346
PageMaker (Integrate text and graphics)	\$ 1025
PagePerfect (European fonts, WP, Graphics and File mgmt.) ..	\$ 505
Ventura Desk Top Publisher (Professional page layout system) ...	\$ 905
DISK, DOS, BACKUP & KEYBOARD:	
Disk Optimizer (Logically organizes data on hard disk) ..	\$ 75
Fansi-Console (Fast, powerful screen & keyboard utilities) ..	\$ 110
FastBack Plus (Backup utility for 5.25" & 5/2 3.5")	\$ 175
FastTrax (Disk optimizer)	\$ 57
Norton Advanced Utilities (Data recov./security, disk mgmt., etc) ..	\$ 149
On-Call (Memory resident. Load up to 40 programs) ..	\$ 82
PC/Tools Deluxe (Memory resident disk & file utility) ..	\$ 75
Q-DOS II (Hard disk file management)	\$ 89
SpeedStor 286 (Integ. hard disks to PC/XT/AT or compat.) ..	\$ 143
Vfeature (Turn one or two hard disks into many)	\$ 117
Vopt (Make your hard disk last longer)	\$ 75
Window DOS (Memory resident disk manager)	\$ 57
EDITORS:	
Brief (Most popular customizable text editor)	\$ 303
MKS VI (Complete implementation of UNIX VI full screen editor) ..	\$ 109
SPF/PC (PC version of mainframe ISPF)	\$ 299
VEDIT PLUS (Windows, menus, word processing)	\$ 191
FORTRAN LANGUAGE & TOOLS:	
Graphic & Plotmatic (75 graphics routines and plotter drivers) ..	\$ 293
Lahey FORTRAN F77-EM/32 (Mainframe prog. extend. mem. 15) ..	\$ 1254
Microsoft FORTRAN Compiler (Mainframe speed, port. code) ..	\$ 527
No Limit Fortran Library (129 func. graphics, screen cont., comm.) ..	\$ 135
RM/Fortran Development Sys. (Inc. Hollerith & Hen constants) ..	\$ 739
GRAPHICS LIBRARIES:	
ADVANTAGE Graphics (Low level graphics/window mgr.)	\$ 265
Essential Graphics (Easy to use. No royalties)	\$ 285
Graphic (Scientific & engineering graphics)	\$ 479
GSS Graphic Dvlp. Toolkit (Complete dvlpt. environ.) ..	\$ 579
HALO'88 (190 functions. Supports many languages) ..	\$ 349
MetaWindow/PLUS (Graphics primitives & window manager) ..	\$ 339
LOCAL AREA NETWORKING:	
Btrieve/N (Supports most networks)	\$ 719
dB_QUERY Multi User (Relational view of LAN database) ..	\$ 747
dB_VISTA Multi User (Supports simultaneous users) ..	\$ 747
FoxBASE+ Multi User (Ultra fast dBASE compiler) ..	\$ 475
Knowledge Network (Easy to install without training) ..	\$ 199
LifeNet 6 Users for 286 or 386 (Powerful & economical LAN) ..	\$ 626
Novell Advanced NetWare 286 (Industry standard LAN) ..	\$ 3119
SFT NetWare 286 W/Keyboard or DCB (W/Sys. Fault Tol.) ..	\$ 5639
Paradox For Network (Easy to use DBMS. Up to 6 users) ..	\$ 1085
MACINTOSH PRODUCTS:	
Copy II Mac (Archival backup for copy protected software) ..	\$ 45
FastBack (Backup utility)	\$ 95
FoxBASE+ for Mac. (Powerful, easy to use DBMS)	\$ 376
FullWrite Professional (Word processing, PostScript support) ..	\$ 452
Guide (Hypertext. Store & retrieve information intuitively) ..	\$ 245
LapLink Mac (Connect PC to Mac. Transfer files rapidly) ..	\$ 149
MacBrain (Best Neural net system available)	\$ 305
Microsoft FORTRAN Compiler (Mainframe speed, port. code) ..	\$ 338
Microsoft BASIC Compiler for Mac (Long awaited for Mac.) ..	\$ 225
Pixel Paint (Full repertoire of minicomputer paint programs) ..	\$ 471
Turbo Pascal (Compiles 27,000 lines per minute)	\$ 117
MODULA-2 LANGUAGE & TOOLS:	
LOGITECH Modula-2 Dvlp. Sys. (Compiler pack plus toolkit) ..	\$ 303
Repertoire/Btrieve Toolkit (Integrate Repertoire w/Btrieve) ..	\$ 155
OBJECT ORIENTED PROGRAMMING:	
ACTOR (Supports MS Windows. Royalty free)	\$ 599

ADVANTAGE C++ (Implementation of AT&T's C++)	\$ 717
Smalltalk/V (Pure object oriented programming. Fast graphics interface) ..	\$ 143
Smalltalk/V 286 (Contains DOS extender. Address 16MB)	\$ 285
Smalltalk/V Communications (Communications)	\$ 75
Smalltalk/V EGA/VGA Colour Pack (Integrate EGA/VGA) ..	\$ 75
Smalltalk/V Goodies (Extend Smalltalk/V environment)	\$ 75
Zortech C++ Compiler (True C++ compiler)	\$ 155
OPERATING SYSTEMS & TOOLS:	
A.I. Dvlpr's Kit Operating Sys. (Protect. mode command shell) ..	\$ 649
Microport DOS Merge 386 (DOS/UNIX environment)	\$ 531
MKS Toolkit (Optimize DOS environment with over 110 UNIX tools) ..	\$ 239
QNX Dvlp. Sys. (Multituser, multitasking real-time LAN Op Sys) ..	\$ 851
SCO VP/IX FOR XENIX 386 (Multi-user, task. DOS under XENIX) ..	\$ 599
SCO XENIX System V Complete 286 (Op Sys, dvlpt. pack) ...	\$ 1559
System V Complete PS/2 Mod. 50/60 (Op Sys, dvlpt. pack) ..	\$ 1679
Microport Sys. V/AT Comp. (Raminus, Dvlp. Sys., & Text prep.) ..	\$ 861
Microport System V/AT Runtime (Op Sys., 180+ utilities)	\$ 333
Wendin-DOS (Multitasking, multiuser Op. Sys.)	\$ 125
OTHER LANGUAGES, TOOLS & MISCELLANEOUS:	
Ada Vantage Compiler (Fast, efficient Ada)	\$ 1197
Baby/36 Automated Conv. Sys. (Run Sys./36 RPL on PC)	\$ 830
Boeing Calc. (3D larger-than-memory spreadsheet)	\$ 359
Carbon Copy 36 (Communications. Remote PC access) ..	\$ 239
CC EXPRESS (Automated, unattended communications)	\$ 419
DESQview (Multitasking, windowing, over 640K)	\$ 149
Framework II (Spreadsheet, Database, WordProc. & Comm.) ..	\$ 715
Math Cad (Statistical and Mathematical)	\$ 415
Microsoft Excel (Spreadsheet)	\$ 581
Microsoft Project (Project Management)	\$ 575
Microsoft Word (Word Processing)	\$ 527
Mirror II (Asynch file transfer & data manager)	\$ 83
PC/FORTH+ (Forth Development System)	\$ 315
Personal REXX (Rexx language interpreter)	\$ 159
PVCS Personal (Version & source code control)	\$ 185
Remote 2 (Powerful remote PC to PC communications)	\$ 185
RPG II Compiler (IBM System/36 compatibility)	\$ 1055
RUNOFF (Text formatter)	\$ 73
SideKick Plus (Desktop management tools)	\$ 231
Swidways (Print text that's too wide for your printer)	\$ 76
SmartTerm 220 (Terminal emulation)	\$ 217
SSP/PC Scientific Subroutine Library (Over 140 subroutines) ..	\$ 389
TimeLine (Project management with mainframe power)	\$ 613
WordPerfect-French (French Word Processing)	\$ 501
PASCAL LANGUAGE:	
Microsoft Pascal Compiler (For large programs up to memory limit) ..	\$ 353
Pascal-2 (Fully integrated development system)	\$ 417
Professional Pascal (Squeeze large programs into minidisk space) ..	\$ 945
Turbo Pascal (Compiles 27,000 lines per minute)	\$ 117
PASCAL LIBRARIES AND TOOLS:	
Pascal TOOLS (Extend power of IBM & Microsoft Pascal)	\$ 173
T-Debug Plus (Powerful debugging for Turbo Pascal)	\$ 59
Turbo Analyst (Turbo Pascal Utilities)	\$ 95
Turbo ASYNCH PLUS (Communications Library)	\$ 157
Turbo Pascal Database Toolbox (Database building kit)	\$ 115
Turbo Pascal Editor Toolbox (Build text editor or w.p.) ..	\$ 115
Turbo Pascal Graphics Toolbox (High-res graphics)	\$ 115
Turbo Pascal Num. Methods Toolbox (Sci./Eng./Math)	\$ 115
Turbo POWER TOOLS PLUS (For Turbo Pascal 4.0) ..	\$ 179
Turbo Professional (Fast general purpose library)	\$ 125
SCREEN DESIGN AND WINDOWING:	
Greenleaf DataWindows W/Src. (Virt. wind. Many data types) ..	\$ 305
Microsoft Windows (Multiple applications environment) ..	\$ 121
Development Kit (Develop graphical multitasking windows) ..	\$ 585
Multi-Windows (Multitasking, simultaneous window display) ..	\$ 389
PANEL Plus (Screen mgmt. library with source, graphics code) ..	\$ 505
PC/Forms (Forms management for C & Pascal)	\$ 215
VCScreen (Screen painter/code generator)	\$ 215
Vitamin C (Windows, data entry)	\$ 275
Windows for Data (Windowing, data entry)	\$ 359
TRANSLATORS:	
BAS_C Commercial (Basic to C)	\$ 305
BAS_C Economy (Basic to C)	\$ 164
BAS_PAS Commercial (Basic to Pascal)	\$ 229
BAS_PAS Economy (Basic to Pascal)	\$ 124
dBX dBASE to C Translator (Run dBASE III Plus in C environment) ..	\$ 721
UNIX/XENIX PRODUCTS:	
BASIC Compiler for Sys. V/286 (Comp. W. BASICA & Q. BASIC) ..	\$ 719
Btrieve (Keyed, indexed file management)	\$ 959
SCO FoxBASE + for XENIX 286 (Run dBASE prog. W/O mod.) ..	\$ 719
Terminal Control for XENIX (Windowing & data entry) ..	\$ 1199

USA SOFTWARE
 LIMMATQUAI 116 • 8001 ZURICH, SWITZERLAND
 PHONE: (01) 252-6710 FAX: (01) 2527795 TELEX: 814460
 (Att: USA SOFTWARE)

Terms: EUROCHEQUE, AMERICAN EXPRESS, VISA, MASTERCARD, EUROCARD, C.O.D.
 30 day billing for qualified companies in Switzerland.
 Special discounts for large or corporate buyers. All prices in US dollars.
 Add shipping charge from Zurich at prevailing rates.
 Prices subject to change without notice.
 Hours: 8:30 AM - 5:30 PM.

Solve Your Document Storage Problems

Archiv 2000 is an optical-disk-based archiving system from Micro Concept No. 1 that provides an integrated solution for document storage.

The system comprises a Zenith 80386-based IBM PC-compatible computer with 1 megabyte of memory, a 40-megabyte hard disk drive, a high-resolution 1280- by 840-pixel display, and a 5 1/4-inch WORM (write once, read many times) optical disk drive. Also included is an A4-size flatbed scanner with a resolution of 300 dots per inch and a laser printer that can print 12 pages per minute, also at a resolution of 300 dpi.

The package includes software to drive the scanner, which lets you scan text and graphics into the computer and transform it into a standard desktop publishing format for storage. You can then store the data on the WORM drive using a relational database package that supports indexed retrieval. Each archive database can have up to 255 information fields, of which 10 can be indexed, with an unlimited number of elements in each index. The system can handle up to 9999 removable WORM cassettes, each of which can hold 400 megabytes of data, or up to 400,000 ASCII text files or 10,000 scanned data files.

Options include a "juke box" that can manipulate up to 64 WORM cassettes, providing 26 gigabytes of storage; a 15-inch paper-white display; a second WORM drive; and on-line technical support via the public Minitel network.

Price: 250,000 French



Micro Concept's Archiv 2000 document storage system.

francs for the basic Archiv 2000 system.

Contact: Micro Concept No. 1, 83-87 Avenue d'Italie, 75013 Paris, France, (1) 45-82-89-09.

Inquiry 833.

Enhanced Graphics Coprocessor Boards

Tektite has added analog palettes, multiplexers, and more memory options to its TT786 range of graphics coprocessor boards, which were previously available only in digital configurations (see What's New International, page 64D, July 1987 BYTE).

The boards feature very large graphics memory, 100 percent compatibility with IBM PC analog and digital graphics, and 20-MHz Intel 82786 drawing speed and windowing capabilities.

The TT786 graphics coprocessors produce both digital and analog monitor signals, driving standard monitors at resolutions up to 800 by 560 pixels. In analog mode, you get 256 colors from a palette of 262,144. The TT786 range is compatible with IBM's CGA and EGA digital graphics adapters and the IBM VGA and PGA analog systems.

Available graphics memory options include 512K bytes, 1 megabyte, 2 megabytes, and 4 megabytes. The memory lets you store and manipulate images up to 8000 by 4000 pixels at 1 bit per pixel or 2000 by 2000 pixels at

8 bits per pixel, while removing restrictions on storing and simultaneously using multiple fonts, sprites, and icons.

You can operate the boards in a single-monitor system, usually using an EGA or MultiSync-type monitor. Other features include hardware drawing at 35 nanoseconds per pixel, hardware windowing, and programming via Tektite's software library.

The TT786 graphics coprocessor boards require a full-size slot in an IBM PC, XT, AT, or compatible.

Price: £395 and up, depending on the configuration.

Contact: Tektite Ltd., P.O. Box 5, Felixstowe IP11 7LW, U.K., (0394) 672117.

Inquiry 875.

Regain Password-Protected Files from SMART

SMACK is a proprietary program designed to help users of Innovative Software's SMART software package to regain password-protected files where the password has been lost, forgotten, or added.

The program is written in Turbo BASIC and is stand-alone, so you don't need the SMART software to run it. SMACK can see the spreadsheet and data-manager screen passwords and resurrect the file-encrypted word processor

documents. SMACK does not find the old password, but adds a choice of two new passwords. File colors, tab settings, and other formatting structures may be lost, and possibly one or two characters at the head of the document can become corrupted, but the file contents remain complete.

SMACK runs under MS-DOS or PC-DOS 2.0 or higher on computers that can run the SMART software package version 2.0 or higher with a graphics card.

Price: \$70 U.S.

Contact: Dandy Computer Services, 36 Avalon Rd., Bridgwater, Somerset TA6 4JE, U.K., (44) 278-424029.

Inquiry 849.

An Error-Correction Module for MNP

Pace Micro Technology offers a plug-in module that adds error correction to Microcom Networking Protocol (MNP) level 4 or EPAD standards to existing modems. You connect the Pace error-correction module between the modem and the computer by plugging it into RS-232C sockets; it is completely transparent to the user. The unit measures only 82 by 33 mm, which was achieved by using surface-mount components.

MNP is emerging as the de facto error-correction standard among modem manufacturers but has no official status as yet. Pace claims that you can upgrade its module by simple software changes to accommodate future error-correction protocols that may emerge.

Price: £149.

Contact: Pace Micro Technology Ltd., Allerton Rd., Bradford BD15 7AG, U.K., (0274) 488211.

Inquiry 993.

continued



Finally, there's an SQL that gets back to BASIC. And COBOL. And C. And Pascal.

As a programmer, you've probably already faced it — the database dilemma. Do you use an SQL for easy database handling, or a true programming language for maximum power and flexibility?

Now you can do both with XQL®, the relational data management system from the developers of Btrieve.®

The Programmer's SQL. With XQL, you can access your data with the ease of Structured Query Language through simple subroutine calls from traditional programming languages. XQL supports standard SQL syntax, including subqueries, unions and security groups.

XQL Relational Primitive Operations.

In addition, XQL lets you bypass the SQL level and perform highly efficient, relational primitive operations directly. You get all the functionality of a relational database model without the constraints of a 4th generation language.

Building on Btrieve. The heart of Novell's family of data management tools is Btrieve. By letting you access multiple records at a time, XQL adds a powerful dimension to Btrieve. XQL incorporates sophisticated data manipulation features which

allow you to access data by field name, move forward or backwards through the database, compute fields from other fields or constants, and even work with composite records built from multiple, joined Btrieve files.

Like Btrieve, XQL offers features like multi-user support, fault tolerance, comprehensive documentation, and expert technical support. And you never pay royalties on your XQL applications.

Solve the database dilemma with XQL, the SQL that speaks your language. See your authorized Novell dealer, or call us for more information.

Novell GMBH
Schiess-Strasse 55
4000 Dusseldorf 11
West Germany
(0211) 59 73-0
Fax 49 211 5911 49
Telex 858 7570

Novell UK LTD.
Avon House
Sweetwell Rd. Bracknell
Berkshire RG12 HH
(0344) 360401
Fax (0344) 860353/4
Telex 846783



*There are more ways than one to have
TEKTRONIX-GRAPHIC'S*

!!!! POLYPHEM S1 !!!!

is one way of bringing high performance graphics
to your screen at a low price

- Polyphem S1/xx is a Tektronix Terminal Substitution Software Package written for IBM-PC's (or compatible) to bring high end Graphics into your Personalcomputer.
- Polyphem S1/xx substitutes Tek 4107, Tek 4111, Tek 4115 and Tek 4125 color graphic terminals.
- Polyphem S1/xx includes a summary of local functions, facilitating your graphic design on a high resolution color monitor (up to 1280 x 1024 pixels).
- Polyphem S1/xx is successfully tested on most of high performance CAD-packages (like ANVIL 5000, STRIM 100, Prime-MEDUSA etc.)!
- **Polyphem S1/xx consists of:**
 - a) software, (4109, 4111, 4115, 4125 soon 4129)
 - b) graphic-controller CADcard 1040
 - c) optional keyboard (enhanced for additional F-keys)
 - d) and documentation
- **Prices:**

Software from 920 to 1630 US\$
Kit (including a, b, c and d):
from 3940 to 4650 US\$

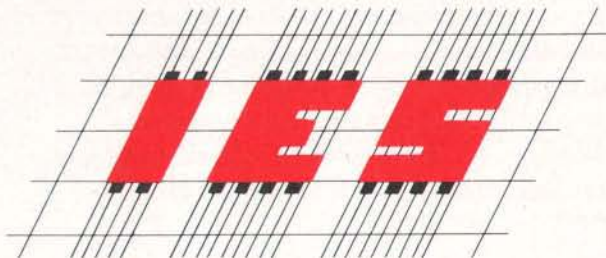

**We are looking for
DISTRIBUTORS
in Europe and worldwide!**

ask us for more information

**I.E.S. GmbH
Jägerweg 10
D-8012 Ottobrunn
West Germany
Tel.: 089/6092023
FAX: 089/6097834**

**I.E.S.
4800 Great America Parkway
Suite 410
Santa Clara, CA 95054
Tel.: 408-970-0771
FAX: 408-748-0984**

Common Lisp with an Interface to X Window

Delphi Common Lisp (DCL) is a complete implementation of Common Lisp, enhanced with the latest recognized standards in the Lisp world, according to Delphi S.p.A. It is the first commercial Lisp offering full production-quality implementations of the Common Lisp Object System and CLX.

The Common Lisp Object System is a standard object-oriented programming facility in accordance with the ANSI X3J13 subcommittee proposal. CLX is the standard interface between Common Lisp and the X Window system.

DCL also includes a multi-thread facility that lets you create and control concurrent threads of program execution.

Language features include more than 700 functions, special forms, and macros; flexible data structuring with support for symbols, lists, arrays, hash tables, strings, arbitrary-precision numbers, and user-defined data types; advanced control structures for iteration, including the ZetaLisp-style LOOP macro, function mapping, and non-local transfer; functional closures that support functional abstraction and object-oriented programming techniques; I/O facilities, including formatted output and streams; and interfaces to C and other languages.

The programming environment includes a compiler;

tracing and single-stepping facilities; an interactive debugger that is invoked on error; an inspector facility that lets you modify data structures; an editor interface that lets you switch from editor context to execution context; a system definition facility for managing the development of large programs; on-line documentation for every function and variable in the system; and an operating-system interface with shell commands that you can execute within DCL.

DCL runs under Unix on a variety of computers, including Sun and 80386-based personal computers.

Price: About \$1500 U.S.
Contact: Delphi S.p.A., Via della Vetraia, 11, I-55049 Viareggio (LU), Italy, (584) 395225.

Inquiry 990.

MIFES for AX and J-3100

Megasoft is developing versions of the MIFES-98 screen editor for the AX machine and the J-3100. MIFES-AX is expected to be roughly the same as the NEC 9801 version in performance and function, while the MIFES J-3100 version will be available in Japanese and English MS-DOS versions. The English MS-DOS version will also run on the IBM PC, XT, AT, and compatibles.
Price: 48,000 yen each.
Contact: Megasoft, Kondo Building 6F, 16-9 Enokimachi, Suita, Osaka 564, Japan, (06) 386-2058.
Inquiry 842.

continued

INTELLIGENT DOCUMENT ENTRY

OCR
TEXIRIS

IMAGE RECOGNITION INTEGRATED SYSTEMS

TEXIRIS APPLICATIONS

- Archiving
- Publishing
- Dedicated OCR
- Databases
- Electronic Mail

TEXIRIS FEATURES

- Pre-trained omnifont OCR
- One-pass scanning of text and graphics
- Automatic high performance recognition
- Learning mode
- Multilanguage lexicons and character set
- Graphical preview of document
- Multicolumn detection and coding
- Adaptability for VAR/OEM applications

Image Recognition Integrated Systems S.A. (I.R.I.S.)
Place de l'Université 4 B -1348 LOUVAIN-LA-NEUVE, BELGIUM
TEL : 32-10-45 13 64 - FAX : 32-10-45 34 43

Use Your IBM PC to Design Schematics and PCBs

HiWire Plus is a menu-driven CAD package from Riva Ltd. that lets you design schematics and printed circuit boards (PCBs) on the IBM PC and compatible computers. The program offers variable trace widths, trace spacing, and pad sizes, which you can choose in multiples of 0.001 inch.

The menus appear only when required, and you use a mouse to operate the system. The package also includes a library of common TTL, CMOS, ECL (emitter-coupled logic), ladder, microprocessor, and discrete components, including surface-mount devices.

You can check a layout against the schematic, and the package checks the line width and spacing, according to your design rules. Once you are satisfied with the layout, you can generate camera-ready artwork on a pen plotter or laser printer.

The program includes PCB netlist extraction and provides conversion from smARTWORK layout files (see What's New International, page 88IS-36, October BYTE). Other features include "rubberbanding" for maintaining electrical connectivity when you move symbols, an Undo command for recovering from mistakes, and a grid-snapping feature for placing objects.

The maximum board size is 1524 by 1524 mm (60 by 60 inches), and HiWire Plus can provide round, oval, square, or rectangular pad shapes. The program can handle layout designs for up to 256 signal layers and features a grid-layout system with 0.001-inch resolution. Multiple windows



Riva's HiWire Plus schematic and PCB design package.

let you display different layout sections simultaneously.

HiWire Plus runs under DOS 2.1 or higher on the IBM PC, XT, AT, and compatibles with a minimum of 512K bytes of memory. A hard disk drive is recommended.

Price: £695.

Contact: Riva Ltd., 3 Bentley Industrial Centre, Bentley, Farnham GU10 5NJ, U.K., (0420) 226666.

Inquiry 867.

Micro Channel Architecture I/O Expansion Cards

The Chase PS range of intelligent serial I/O controller boards supports the Micro Channel architecture of the IBM PS/2s and extends the connectivity of IBM PS/2 computers into high-performance multiuser systems for up to 64 users, according to Chase Research.

The range includes serial I/O controllers with 4, 8, and 16 ports. Each board features a dedicated 80186 microprocessor that manages the serial ports and off-loads I/O overhead to its own microprocessor. Data transfers

to and from the central microprocessor are through a dual-ported shared-memory interface, which, according to the company, is a unique feature. You can configure each port independently for data transfer rates from 45 to 38,400 bps and for parity and word length. The PS boards also support downloadable code, which gives you greater flexibility in the operating systems and devices supported.

The Chase PS4 controller is a 4-port board with an RS-232C interface and RJ-11 telephone-jack-style connectors. The Chase PS4+ has 4 ports with four DB-25 connectors, the Chase PS8 has 8 ports with 8 DB-25 connectors, and the Chase PS16 has 16 ports with 16 DB-25 connectors. The Chase PS4+, PS8, and PS16 boards also come with distribution boxes that contain an RS-232C interface; an RS-422 distribution box is available as an option. You can insert combinations of up to four Chase I/O boards in an IBM PS/2, to allow up to 64 users to join the system.

The Chase I/O controllers were also designed to improve the I/O performance of Unix/Xenix/AIX running on the IBM PS/2s by moving character translation, line editing, echoing, and buffering from the central microprocessor to the I/O microprocessor. A device driver for SCO Xenix V is supplied as standard, while a device driver for the IBM AIX PS/2 version of Unix will be available shortly after the release of AIX PS/2, according to the company.

Price: £495 for the PS4; £695 for the PS4+; £995 for the PS8; £1495 for the PS16.

Contact: Chase Research Ltd., Unit 5, Metro Industrial Centre, St. Johns Rd., Isleworth, Middlesex TW7 6NJ, U.K., (01) 847-1557.

Inquiry 845.

Aztec C for the Atari ST

The Aztec C compiler for the Atari ST helps you generate fast, compact programs, with libraries conforming to the draft-proposed ANSI standard, as well as Unix, general-purpose, and Atari-specific libraries. The linker lets you produce overlays and generate information for use by debuggers.

Two versions are available: the Professional System and the Developer System, which includes Unix utilities and the v1 editor.

Optional extras include the full source code of all the libraries and a source code debugger.

Price: £129 for the Aztec C Professional System; £179 for the Aztec C Developer System.

Contact: HiSoft, The Old School, Greenfield, Bedford MK45 5DE, U.K., (0525) 718181.

Inquiry 881.

continued



Model	CPU	Speed (MHz)	Main Memory	Hard Disk Drive	Floppy Disk Drive	Serial/Parallel Ports	Expansion Slots/ (free)	Mono System	EGA System	VGA System
PC-88C Compact	V20 (8088)	4.77/10	640K	20MB (65mS)	360K	1/1	4/(2)	£775	£1075	£1275
PC-88S	V20 (8088)	4.77/10	640K	20MB (65mS)	360K	1/1	8/(4)	£875	£1175	£1375
PC-286C Compact	80286	8/10	640K	40MB (40mS)	1.2MB	2/1	6/(4)	£1375	£1675	£1875
PC-286S	80286	8/12	1MB	40MB (40mS)	1.2MB	2/1	8/(5)	£1495	£1795	£1995
PC-386S	80386	20	2MB	44MB (28mS)	1.2MB	2/1	8/(5)	£2795	£3095	£3295

Each system includes a keyboard, monitor, mouse, MS-DOS 3.3, BASIC, GEM (1st Word Plus, Paint), and full set of manuals, and is backed up by our Technical Hotline Support and 12 month warranty. On-site maintenance is also available.

DISK UPGRADE: 40MB to 44MB (28mS) = £150, 44MB to 72MB (28mS) = £100, 44MB to 135MB (18mS) = £900.

OPTIONS: OS/2 for PC-286 and PC-386 ranges. Maths co-processors, 720K/1.44MB FDDs, tape-streamers, printers, plotters, and networking cards.

Authorised supplier of XENIX and NOVELL.

Please feel free to visit our showrooms.

Elonex (UK) Ltd., Rays House, North Circular Road, London NW10 7XB.
Telex 946240 CWEASY-G/REF. 19020170, Fax 01-965 3246

Elonex (UK) Ltd., 7-9 Campus Road, Bradford Science Park, Bradford,
West Yorkshire BD7 1HR. Fax (0274) 307294.

Tel 01-965 3225

Tel (0274) 307226

All prices are exclusive of carriage and VAT. Prices and specifications are subject to change without notice.
MS-DOS, XENIX, OS/2 and NOVELL are registered trade marks.

Circle 434 on Reader Service Card

NO BULL



Add a Static RAM Disk to Your Apple II

XAPLDSK is a 160K-byte static-RAM-based board for Apple II computers that has enough battery backup to retain data for 10 years, according to XCalibur Computers.

In use, XAPLDSK operates just like a DOS 3.3 disk. You can format it, remove it from the computer, and transfer it to another computer, booting at switch-on as usual. The card is designed for use in adverse environments, where dust, noise, wear, and vibration may give you unreliable operation on rotating or mechanical storage devices.

XAPLDSK retains full compatibility with conventional disks and has a write-protect link, which you can make as required. The package includes the card and a configuration disk.

Price: £350.

Contact: XCalibur Computers Ltd., Kent House, 30 Billing Rd., Northampton NN1 5DQ, U.K., (0604) 259211.

Inquiry 870.

A Programming Tool for Graphics in C

Kessler Softwareentwicklung offers C_Graph, a programming tool that supports interactive, device-independent graphics in C using the Graphics Kernel System (GKS) standard. C_Graph offers two user interfaces: the GKS standard level 2b (ISO 7942) and the ACM SIGGRAPH CORE system, which Kessler has extended with extra functions. Many of the functions are shared by both interfaces, so you can use them interchangeably.

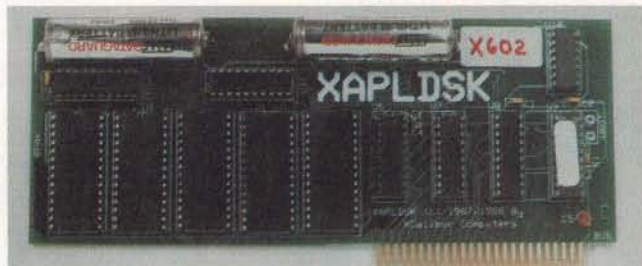

XCalibur's XAPLDSK, a static RAM board for Apple IIs.

The C_Graph library lets you program graphical applications using a problem-related coordinate system, which automatically transforms your coordinates into device-specific formats and gives the programs portability over a range of devices. C_Graph supports six classes of logical input devices, corresponding to devices like mice, digitizing tablets, keyboards, joysticks, and light pens.

C_Graph supports drawing primitives, such as polyline, polymarker, text, and fill-area; primitive figures such as arcs, circles, ellipses, and elliptical arcs; viewports; and clipping. A shielding feature lets you display all of a picture that falls outside the clip rectangle.

You can divide pictures into segments, each of which can hold as many graphics items as memory permits. You can add segments at any time and display and hide them in any order.

C_Graph comes as a set of compiled C libraries, which are compiled for a large memory model. The compilers it currently supports include Microsoft 4.0 and higher, Lattice 3.1 and higher, and Borland Turbo C 1.5 and higher. The program operates on MS-DOS computers running under version 2.1 or higher with 384K bytes of memory; 512K bytes of memory and a hard disk drive are recommended. Drivers are included for a number of output and input devices, and Kessler also supplies a device-driver kit, which contains the

source code for the existing drivers, so you can write your own. The company claims that a Unix version is under development.

Price: 798 deutsche marks for the Professional system; 350 deutsche marks for the device-driver construction kit. **Contact:** Kessler Softwareentwicklung, Mitteldorfstrasse 17, 3400 Gottingen, West Germany, (0551) 792488.

Inquiry 829.

Intelligent Document Entry

You can automatically enter documents into archiving, publishing, and office automation applications with Texiris from Image Recognition Integrated Systems. The system consists of a full-size add-in board, a scanner interface, and custom optical-character-recognition (OCR) software that incorporates artificial intelligence techniques.

Texiris works in three modes: Mode A offers automatic separation of text and graphics, mode M offers user-defined separation via measured windows, and mode P offers interactive preview on a Hercules, CGA, or EGA monitor and definition of text and graphics by pointing with a mouse.

The add-in board is based on two custom VLSI devices, called the Document Analyzer and the Structural Analyzer. The system analyzes the characters using feature-recognition techniques,

which, unlike most current OCR programs, does not require the learning of fonts.

Texiris can read a page of mixed graphics and text in one scanning pass and separate pictures from text without a learning phase. It can recognize multiple fonts mixed together, as well as foreign-language characters and type-written text. The company claims the system has a recognition accuracy of 99.9 percent for over 20 fonts, including Courier, Prestige, Elite, Times, Helvetica, and several italic faces. You can save the separated graphics in a variety of compressed or uncompressed formats, such as TIFF, Microsoft Paint, and GEM, and you can output to popular text editors and publishing software.

The OCR software extracts the parameters of the text, such as multiple columns, underlines, paragraphs, hyphenation, and justification, and it retains them in the computerized document. It runs under DOS 2.0 or higher on the IBM PC, XT, AT, PS/2s, 80386-based, and compatible computers with at least 640K bytes of RAM. A version is also available for the VMEbus running under Unix.

Texiris supports most popular full-page scanners, such as those from Agfa, Canon, Microtek, Hewlett-Packard, Datacopy, Ricoh, and Princeton. It can output file formats such as ASCII, WordStar, WordPerfect, MultiMate, Microsoft Word, and DisplayWrite. Options include a lexical error-detection and correction facility. **Price:** 195,000 Belgian francs and up.

Contact: Image Recognition Integrated Systems sa, 4 Place de l'Universite, B-1348 Louvain-la-Neuve, Belgium, 32-10-451364.

Inquiry 995.

continued

Millennium: you'll find it's been worth the wait.



No other computer can satisfy your requirements so completely:-

COMPACT SIZE

HIGH PERFORMANCE

ULTIMATE RELIABILITY

TOTAL IBM PC COMPATIBILITY

EXPANSION CAPABILITY

LATEST GRAPHICS

A STYLISH PACKAGE

COMPETITIVE PRICING

PRICES RANGE FROM \$1376 - \$5828

Now you really can have everything you ever wanted in a PC-AT workstation.

No compromises.

No disappointments. Just powerful, perfect performance.

To find out why the Millennium by HM Systems is genuinely different and better than the rest of the PC market, dial 100 and ask for Freephone HM Systems or complete the coupon TODAY.

For technical interest:-
16 or 20 MHz processor
VGA graphics (640 × 480 resolution in 16 colours or 320 × 200 in 256 colours)
1 to 5Mb of zero wait state memory
1.44Mb 3.5" Floppy disk drive
42 or 128Mb* Winchester disk drive
Stunningly fast Intelligent disk controller employing caching, 1:1 interleave, zero latency, elevator seeks, dual ported RAM, battery backup
One serial port
One parallel port
Bus mouse port and mouse
Ultra small size W290 D396 H100 mm
Password protection
3 year warranty
*Available 4th quarter '88

HM Systems plc,
Minstrel House,
220 The Vale,
London, NW11 8HZ.
Tel: 01 209 0912
Fax: 01 209 0912
Tel: 01 209 0911 or dial 100 and
ask for Freephone HM Systems

HM Systems plc

NAME _____

COMPANY _____

JOB TITLE _____

ADDRESS _____

POSTCODE _____

TELEPHONE _____ **BY1**

An IBM PS/2 Model 30 Compatible

The Superset-30 Plus is fully compatible with the IBM PS/2 Model 30. It includes VGA circuitry on the main board, which gives the computer enhanced video display capabilities, and it operates 25 percent faster than the Model 30, according to Twinhead International.

The standard configuration includes a 10-MHz 8086 microprocessor operating with zero wait states, 640K bytes of memory, a Phoenix BIOS, two 3½-inch floppy disk drives, an RS-232C serial port, a Centronics parallel port, and a Microsoft Bus Mouse-compatible port. Three IBM PC XT expansion slots, a dedicated I/O bus with speed switching, and a built-in speaker are also included.

The custom-designed analog VGA monitor outlet is also compatible with the IBM CGA, EGA, HGC, and MDA, with BIOS-level compatibility with MCGA supporting IBM PS/2 software. Color monitor options include a 14-inch monitor with a nonglare tinted screen and a tilt-and-swivel stand.

Other features include a keylock, a real-time clock with battery backup, an 8087 coprocessor socket, front-panel power and reset switches, and a 101-key Enhanced keyboard.

Price: \$950 U.S. and up, depending on the configuration.

Contact: Twinhead International Corp., 6th Floor, 604 Min Sheng East Rd., Taipei, Taiwan, R.O.C., (02) 713-3450.

Inquiry 879.



The Superset-30 Plus includes VGA circuitry.

Digital Ground Modeling for the IBM PC

L.M. Technical Services Ltd. has written a version of its minicomputer-based Digital Ground Modeling (DGM) software that runs on the IBM PC and compatibles without special hardware assistance. The software helps you produce three-dimensional plots of the earth's surface from survey data, such as charts, maps, boreholes, and echo soundings, as well as from xyz data you have abstracted from files generated with an editor or digitizing tablet.

You can display a surface model on-screen and subject it to a range of effects, such as rotation, zoom, partition, and comparison. The program lets you section a model between any points and plot the result at any resolution. You can also calculate volumes, surface areas, gradients, and grid levels, and output them to an ASCII file.

The software lets you sub-

tract two digital ground models at high speed to produce a Difference Model that you can use for infill calculations or for visualizing the stages of a project. The Partitioning function lets you see details, such as the extent of flooding on an area or the capacity curves of a water reservoir. The data-filtering module helps you detect incorrect readings and remove them from a plot.

Digital Ground Modeling software runs under PC-DOS 2.0 or higher on the IBM PC, XT, AT, and compatibles with at least 312K bytes of memory, a hard disk drive, and a Hercules, CGA, EGA, or VGA monitor. It can handle contour, isometric, and perspective output to Hewlett-Packard Graphics Language-compatible plotters, and you can generate the output in a format suitable for transfer to popular CAD and desktop publishing packages.

Price: £585.

Contact: L.M. Technical

Services Ltd., Unit 310, Solent Business Centre, Millbrook Rd., Southampton, Hampshire SO1 0HW, U.K., (0703) 702328.

Inquiry 992.

Give Your IBM PC 96 I/O Channels

The DIGIO and DTU combination of I/O boards from XCalibur Computers offers you 96 channels of digital termination, data communications, and a real-time clock for your IBM PC, XT, AT, or compatible.

DIGIO is a plug-in printed circuit board with up to 96 channels of programmable digital I/O and a real-time clock. You can use the real-time clock to generate periodic interrupts for real-time control applications. You connect plant inputs via ribbon cables. You can use DIGIO for applications requiring large amounts of digital sensing or control.

The Digital Termination Unit (DTU) is a mass-termination panel that offers screw-down and plug-in connections for industrial signals. Inputs are optoisolated digital signals, while outputs can be either voltage-free relay contacts or Darlington Drivers. In both cases, wetting voltages can be provided externally from the plant or from the DTU.

In addition to 96 channels of termination, the DTU offers two independent data-communication conversion circuits. These convert from the TS-232C standard to RS-422 or RS-485.

Price: £200 for DIGIO; £100 for DTU, both depending on the configuration.

Contact: XCalibur Computers Ltd., Kent House, 30 Billing Rd., Northampton NN1 5DQ, U.K., (0604) 259211.

Inquiry 878.

continued

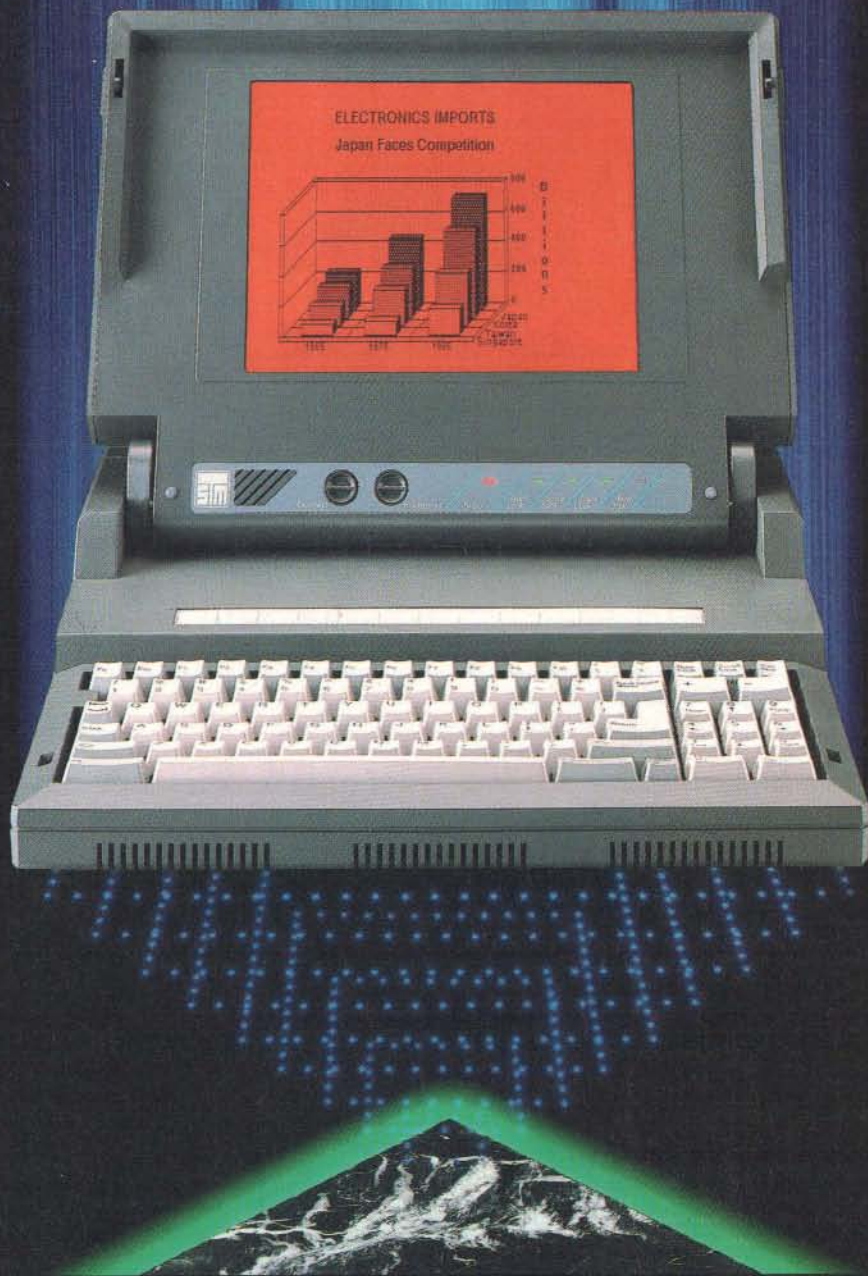

STM · 5500

PORTABLE PERSONAL COMPUTER

- 80286 running at 12 MHz/6MHz
- 1 Mb RAM: Expandable internally to 3 or 5 Mb RAM
- Internal 40 Mb hard disk drive
- Internal 3.5" 1.44 Mb microfloppy disk drive
- 640 x 400 pixel gas plasma display with four grey scales
- IBM (EGA) and IBM (CGA) compatible
- Also MDA and Hercules compatible (on external monitor)

Interfaces:

RGB connector/external keyboard port/parallel port/RS 232C/RJ-11

Size/Weight:

36 W x 8.6 H x 36 D cm — 6.8 kg

Options:

- Internal/2400 bps Hayes compatible modem (CCITT)
- Internal 2 Mb (4 Mb) Extended Memory card
- Expansion chassis for IBM PC/AT type card

IBM and PC/AT are registered trademarks of International Business Machines Corporation. Hercules is a trademark of Hercules Computer Technology Inc.



For distribution please contact:

SEMI-TECH MICROELECTRONICS CORPORATION

P.O. Box 3009, Markham Industrial Park

Markham, Ontario, Canada L3R 6G4

Fax: (416) 475-1552 Telex 06-986749

Image Scanning with a Choice of Resolutions

The FX-RS505 flatbed image scanner features variable resolutions, selectable from 200, 300, or 400 dots per inch; at 400 dpi, Panasonic claims it can scan an A4 page in 13 seconds. You can also use the scanner in conjunction with Panasonic's FX-BM89 fax card to scan images that you can send as facsimiles.

The scanner comes with Panasonic's Panascan software, which lets you save images in a format you can use with many desktop publishing packages. Also supplied are Microsoft's Scan-Do windowing software and



Panasonic's FX-RS505 flatbed image scanner.

drivers for GEM Scan. Optional optical-character-recognition software lets you turn printed copy into ASCII data for editing with standard word processing software.

The FX-RS505 comes with an interface card that requires a full-size slot in the computer. Panascan and Scan-Do run under DOS 2.0 or higher

on the IBM PC, XT, AT, and compatibles with a minimum of 640K bytes of memory. A hard disk drive is recommended.

Price: £1195.

Contact: Panasonic Industrial U.K., 280-290 Bath Rd., Slough, Berkshire SL1 6JG, U.K., (0753) 73181.

Inquiry 997.

Unix-Oriented 32-bit Minis

Forum International offers the MultiFlex 32-05 and 32-10, a line of Unix-oriented 32-bit minicomputers based on the National Semiconductor 32.332 processor. The minicomputers feature removable disk packs, each with an individual controller. This modular construction lets you start with an 80-megabyte hard disk drive and easily upgrade to 160 megabytes by adding an additional disk pack. You can also switch to optical disk storage in the future.

The desktop 32-05 system has 4 megabytes of memory, accepts 80- to 150-megabyte hard disk drives, and supports

continued

BYTE BACK ISSUES FOR SALE

	1986	1987	1988
January			
February			
March			
April			
May			
June			
July			
August			
September			
October			
November			
December			
Inside the IBM PCs			

Issues Available

Rates (postage and handling included):

Holland	Dfl 18.00	Switzerland	SwFr 13.50
United Kingdom	£ 5.25	France	FFr 54.50
West Germany	DM 16.50	Sweden	SEK 56.50

No other currencies will be accepted other than those mentioned above.

Please indicate which issues you would like by checking (✓) the boxes. Send requests with payment to:

BYTE Back Issues, c/o Dynamic Graphics International, P.O. Box 25, 3950 AA Maarn, The Netherlands

Check enclosed

Charge: MasterCard Eurocard
 American Express

Card # _____

Exp. Date _____

Signature _____

Name _____

Address _____

Postcode _____ City _____

Country _____

All orders must be prepaid. Pay only in currencies given. Please allow four weeks for delivery by surface mail.

NEW M380 LINE: NOW MORE THAN EVER THE SPEED AND POWER TO GROW WITH YOU.

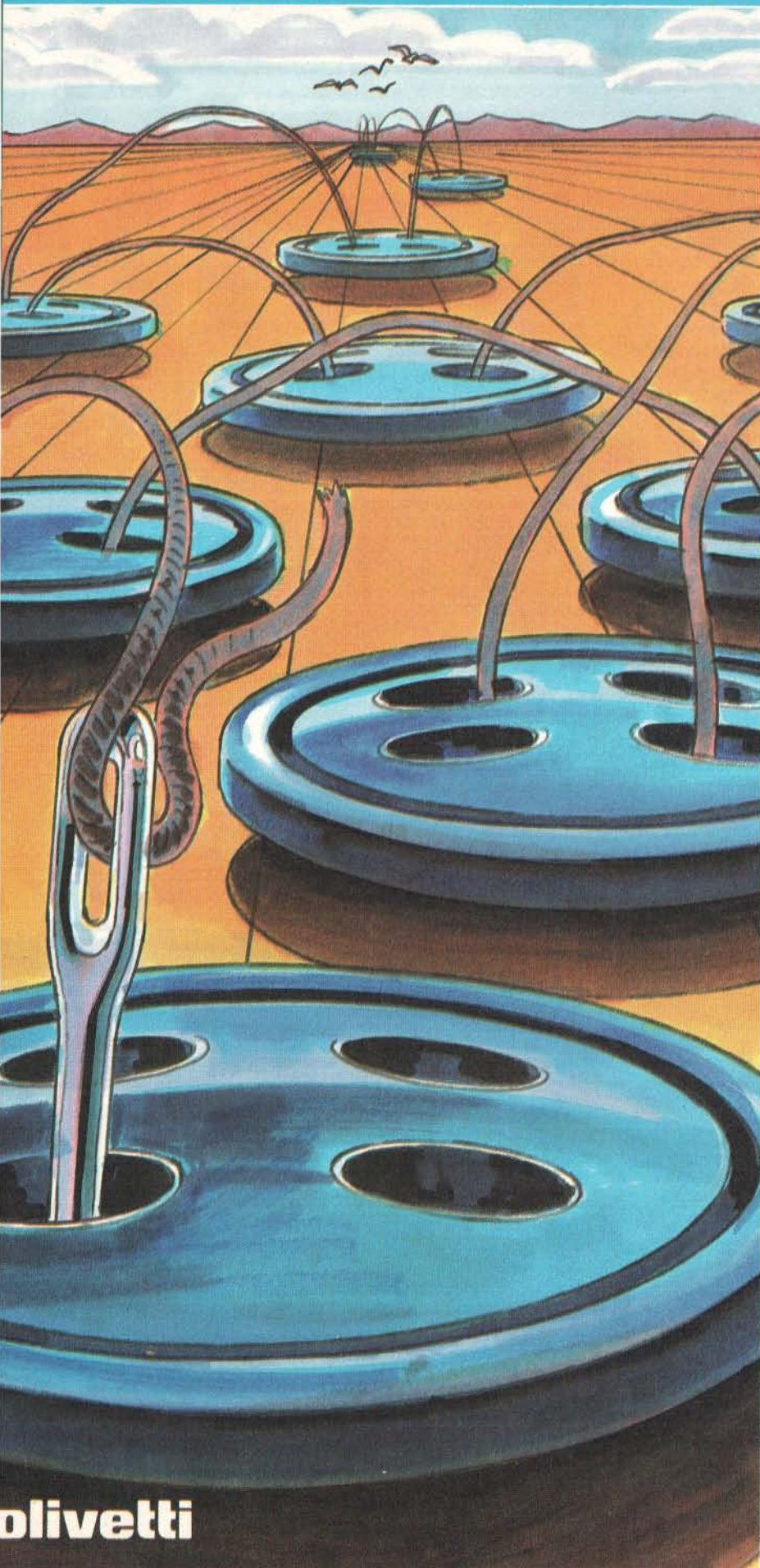

To keep you abreast of advances in the important Intel 386™ sector, Olivetti has up-dated its powerful 386™-based M380 line.

The new line is among the fastest on the market, and more powerful XP (extra performance) models are introduced at the top end. Top of the new line is the floor-standing M380/XP5 with a 20 MHz clock speed. Hard disk options range up to 300 MB. The XP5 also offers the new graphic subsystem OVC (VGA-compatible). The new M380/XP3 has 2 MB RAM and a clock speed of 20 MHz, plus a 135 MB hard disk unit. It too has the OVC graphic subsystem as part of the standard configuration.

The new M380/XPI compact desktop PC has an 80 MB HDU. With a clock speed of 20 MHz, it offers 1 MB RAM and OVC graphic subsystem as standard. The new M380/C has an improved HDU capacity of 63 MB, OVC graphic subsystem and a clock speed of 16 MHz. All

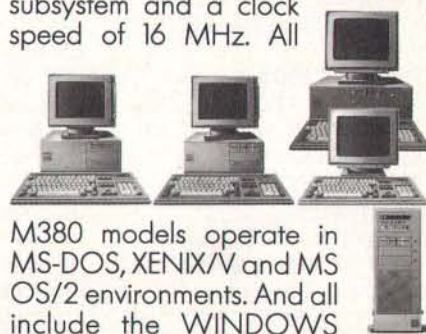

M380 models operate in MS-DOS, XENIX/V and MS OS/2 environments. And all include the WINDOWS 386 package to meet all current and future applications.

The new M380 line. Yet another way in which Olivetti is honouring its commitment to bring you the choice of freedom.

386 is a trademark of Intel Corporation. MS-DOS, XENIX/V, OS/2 and MS-Windows are registered trademarks of Microsoft Corporation. Specifications and conditions subject to change without notice.

OLIVETTI PERSONAL COMPUTERS.

CHOICE OF FREEDOM.

Circle 452 on Reader Service Card

olivetti

up to eight users. The MultiFlex 32-10 has 8 to 16 megabytes of memory, accepts hard disk drives in 80-, 150-, 300-, 600-, or 1200-megabyte sizes, and supports up to 32 users. The 32-10 also comes with an Exabyte 8-mm streaming tape drive that saves up to 2.4 gigabytes of data.

Forum International designed and patented four gate arrays that consolidate over 300 ICs on a single board, which incorporates all the minicomputer's electronic functions. The MultiFlex 32-05 and 32-10 also include a safety battery, a power supply controller, and an I/O coprocessor.

A third minicomputer, the MultiFlex 32-20, is based on the National Semiconductor 32.532 chip, which will give you a processing speed of 10 million instructions per second. The 32-20 will include 8 to 32 megabytes of memory, will accept 150-, 300-, 600-, 1200-, or 2400-megabyte hard disk drives, and will support up to 64 users. The company claims that the MultiFlex 32-20 will be released in mid-1989.

Price: \$24,000 to \$32,000 U.S. for the 32-05; \$44,000 to \$110,000 U.S. for the 32-10; \$55,000 to \$170,000 U.S. for the 32-20, all depending on configuration.

Contact: Forum International, 19 Avenue du Quebec, 91951 Les Ulis Cedex, France, (1) 64-46-19-00.
Inquiry 873.

Drawing Office Management

Practical Technology has designed its DAXDMS Drawing Office Management System to meet the specific requirements of most drawing or design offices. The system's flexibility lets you tailor it

for use in mechanical, electrical, architectural, and civil-engineering design offices, as well as for the electronics and construction industry.

You can use the system as a drawing register or for maintaining complex drawing structures, linking assemblies, subassemblies, and parts, according to your specifications. Also, you can link DAXDMS with CAD systems such as DAXCAD or AutoCAD.

With DAXDMS, you get a drawing register and facilities for drawing administration, drawing control, and reporting. The core of the system is the drawing register, which helps you maintain a record of all drawings, including information on required drawing media and their location. It automatically numbers drawings and lets you store textual information with corresponding drawing numbers.

You can use the drawing administration function to maintain product structures; enforce issue and change control, including an audit history; maintain circulation lists; and create building standards. Drawing control lets you restrict access to drawings, perform work authorization, and exchange information between DAXDMS and CAD programs.

With the reporting function, you can generate reports such as drawing registers; design transactions; department lists; change notes; drawing lists by reference number, product codes, customer numbers and contract numbers; customer lists; contract lists; issue numbers and description prints; change requests; building standards; and data file reports. The reports are generated from the structures menu and the reports menu. You can output them to

the screen or a printer or write them to a file for later processing.

DAXDMS runs under DOS 3.10 or higher on the IBM PC, XT, AT, and compatibles with 640K bytes of RAM and a hard disk drive with at least 6 megabytes of free space. The system also runs under Unix on Sun and Apollo workstations. The system comes with an example database and an empty database.

Price: £725.

Contact: Practical Technology Ltd., Clutha House, 120 Cornwall St. S, Glasgow G41 1AD, U.K., (041) 427-5371.

Inquiry 844.

A Worksaver for Teachers

You can create tests, questionnaires, and quizzes of various types with Question Mark. Tests can contain up to 500 questions, which can be multiple choice, numeric, fill-in-the-blank, word answer, free format, ranking, multiple selection, or a comment that requires no answer, and questions can have more than one correct answer.

The computer automatically marks a student's performance on a test, and it can make some intelligent decisions, such as allowing for simple misspellings in answers. When a question is answered incorrectly, the teacher can add a one-line explanation with the correct answer and then present the student with a corrected copy of the test. The program lets you store answers and marks on a disk for future reference.

Question Mark runs under DOS 2.0 or higher on the IBM PC, XT, AT, and compatibles with 384K bytes of memory, a graphics adapter, and either a floppy disk drive or a

hard disk drive. Site licenses for large institutions are also available.

Price: £98 for the teacher program (which creates tests) and a single-copy license for the student program (which asks the tests).

Contact: Question Mark Computing, 77 Rossendale Way, London NW1 0XA, U.K., (01) 388-2329.

Inquiry 834.

Let This Program Execute Tasks for You

The Clockwork Executive is a multitasking software tool designed for use in data acquisition, automatic testing, and laboratory systems.

An interactive screen-based interface lets you define the name, scheduling frequency, and start/stop times for each task. The program then executes each task at the frequency you specify.

The Clockwork Executive controls up to eight tasks. Each task is a standard .EXE file that occupies up to 64K bytes of memory, reads and writes standard MS-DOS files, creates on-screen graphics and reports, and communicates with other devices, including keyboards, printers, and serial ports.

System calls provide additional functions, such as task-generated requests and control over access to the keyboard and screen.

The Clockwork Executive runs under DOS 2.0 or higher on the IBM PC, XT, AT, and compatibles with at least 640K bytes of memory.

Price: £195.

Contact: Alan Cohen Computer Consultants Ltd., 225a Finchley Rd., London NW3 6LP, U.K., (01) 435-5493.

Inquiry 880.

continued

D-Link®

Local Area Network

The Smart Solution To Your Multi-User Needs

Industry Standard

D-Link hardware and software products are designed to meet the industry-standard. This guarantees you against obsolescence, and ensures a long-lasting return on your investment.

Our high performance Ethernet Interface Card can network any combination of PC/XT/AT and PS/2 Micro Channel™, to share valuable resources across the network. Furthermore, it has the ability to support TCP/IP, NETBIOS, Novell's NetWare™, IBM PC LAN Program and Sun Microsystems' PC-NFS™ software.

Our LANsmart Network Operating System is NETBIOS compatible and supports DOS 3.1 file/record locking standard. Hence, you can run all third party multi-user application software available on the market.

Ease of Use

D-Link LAN products are extremely easy to install and operate. Using pop-up windows, all options are listed on the screen for your ready selection to guide you through each operation.

Affordability

D-Link is designed for cost conscious users and carries a very reasonable price tag. Following the industry standard, D-Link is compatible with all major LAN products which ensures that your LAN will never become obsolete.



DATEX
SYSTEMS INC.

15-4 Fl., No. 1, Fu-Hsing North Rd., Taipei, Taiwan, R.O.C.
Tel: (02)773-2980 Fax: 886-2-781-5826 Telex: 10971 DATEX

IBM PC/XT/AT, PS/2, Micro Channel are registered trademarks of International Business Machine Corporation.
NetWare is a registered trademark of Novell Inc.

Ethernet is a registered trademark of Xerox Corporation.
LANsmart and D-Link are registered trademarks of Datex Systems Inc./Localnet Communications Inc.

Circle 432 on Reader Service Card

NOVEMBER 1988 • B Y T E 881S-21

“We have just finished our first Multi-Lingual Scholar™ produced job — a service manual in Russian for SAAB Marine Electronics. The result was quite good and the customer is satisfied. It seems we cut his costs some 30%.”

— *TEKNISK SPRÅKSERVICE*
Västra Frölunda, Sweden

SOFTWARE THAT SPEAKS YOUR LANGUAGE

Multi-Lingual Scholar™, a single software program for wordprocessing and high quality printing with multiple languages in the same document. Supports on-screen foreign characters — with accents and vowel points — with no hardware modifications. Arabic, Farsi and Hebrew edit right to left, and a font editor lets you design your own characters and customize keyboard layouts.

- Standard package includes 5 alphabets: Roman (for English, European and Scandinavian languages), Arabic/Farsi, Cyrillic, Hebrew and Greek. Supports 9-pin and 24-pin dot matrix printers. \$350 + \$20 s/h
- Also available with Hindi (Devanagari) replacing Hebrew. (Laser Printer option, \$150 additional.)

- Optional languages available: Armenian, Amharic, Sanskrit, Indian dialects, Syriac and most ancient Biblical languages; please inquire.

- Demo program — same as standard package except file size and printing have been limited. Comes with tutorial. \$15 (applies toward purchase) + \$7 s/h.

VISA/MC/AMEX.
or bank draft
in US dollars
accepted. Or write
for a list of
dealers
world-wide.

**Multi-Lingual
Scholar™**

A product of
Gamma Productions, Inc.

710 Wilshire Boulevard, Suite 609
Santa Monica, CA 90401 USA
Tel. 213-394-8622

Tlx: 510 600 8273 Gamma Pro SNM

Requires: IBM PC/XT/AT or compatible, 640K, graphics (Hercules CGA, or EGA), 1 disk drive, 1 parallel port. Works with most dot matrix (9- and 24-pin) printers and Hewlett Packard Laserjet+/Series II or compatible laser printers.

A 33-inch Autoscan Monitor

Mitsubishi's new auto-scanning color monitor, called the XC-3320C, features a 33-inch screen and can accept TTL, analog, and PAL video inputs, so you can use the monitor in interactive video and videotex systems.

The monitor's autoscaning circuitry automatically switches to vertical scan frequencies between 40 and 75 Hz and horizontal scan frequencies between 15 and 35 kHz. The maximum display resolution is 640 pixels by 200 to 480 lines, noninterlaced, which Mitsubishi claims makes it suitable for business, education, and low-end CAD/CAM graphics applications, as well as for financial trading displays.

The XC-3320C comes in a cabinet 770 by 649 by 570 mm in size, with front-panel controls for tint, color, sharpness, contrast, and brightness.

Other controls include RGB H-phase, H-width, V-position, V-height, audio balance and volume, and source select for RGB or video signals. The monitor is fully compatible with the IBM PC, PS/2, and Apple Macintosh II display standards.

Price: £5000.

Contact: Mitsubishi Electric U.K., Travellers Lane, Hatfield, Hertfordshire AL10 8XB, U.K., (07072) 76100.
Inquiry 991.

Professional CAD for Archimedes

Oak PDT (Parametric Design Tool) is a professional-quality CAD program for the Acorn Archimedes Models 310, 410, and 440. Unlike conventional coordinate-based CAD systems, PDT stores the details of the

relationships between the component parts of a drawing. For example, if you define a line as being tangential to two circles and then move one or both of the circles, the program redraws the line so that it remains tangential. According to the company, this parametric system lets you edit drawings much faster, because you don't need to spend time restoring the relationships between drawing components.

PDT also features automatic associative dimensioning to the British Standard BS308, so that the dimensions automatically adjust when you edit a drawing. You can perform spreadsheet-style "What If?" investigations on a drawing by altering the dimensions and then observing the results until the best solution is found. You can also draw mechanical linkages, such as levers and cranks, and then simulate their operation as continuous motion or by discrete steps on the computer model.

CAD facilities such as zooming, panning, numerous line styles, text placement, and 16 drawing layers are provided, which you can select for displaying and plotting and protect from editing or deleting. An on-line help system explains menu options, and you can export drawings to popular desktop publishing packages. Oak PDT supports Hewlett-Packard Graphics Language-compatible plotters and Epson-compatible dot-matrix printers; you can also attach custom screen-dump routines to interface to nonstandard printers.

Price: £295.

Contact: Oak Computer Ltd., Cross Park House, Low Green, Rawdon, Leeds LS19 6HA, U.K., (0532) 502615.
Inquiry 994.

continued

PS/2 and PCL - a powerful pair. . .

Benchmark	Turbo Pascal 4	Turbo C 1.5	Quick C 5.1	MS C 5.1	PCL 3.0
BYTE Magazine FLOAT benchmark	6.65	5.15	10.22	9.78	4.60
With 80387:	0.39	0.49	0.49	.049	0.38
Convert 10000 decimals to character strings	2.48	11.87	14.66	13.78	3.35
With 80387:	2.69	2.47	7.52	7.31	1.43
Convert 10000 char. strings to decimals	7.14	9.51	14.17	13.29	2.41
With 80387:	3.13	4.50	6.53	6.49	1.37
Sort array of 20000 random integers with built-in SORT.	-	4.61	4.84	4.83	0.61
Sort array of 5000 random decimals with built-in SORT.	-	13.90	22.62	15.43	0.66
With 80387:	-	1.87	2.75	2.09	0.66
Sort array of 5000 random 8 byte strings with built-in SORT	-	2.14	2.25	2.25	0.94
Sequential write, 100000 x90 byte records	31.4	31.0	31.5	31.0	10.2
Sequential read, 10000 x90 byte records	31.3	30.9	31.4	31.3	9.2

Manufacturers: Turbo Pascal, Turbo C = Borland. Quick C, C 5.1 = Microsoft. PCL = Calend. All timings are in seconds. They were all taken under identical conditions on a 16MHz IBM PS/2 80 and PC DOS 3.3, without a diskcache and BUFFERS=20 in CONFIG.SYS. Turbo Pascal has no built-in Sort.

But execution speed tells only half the story. . .

PCL's text string handling, window management, communications are superb. You can design elegant and professional screens with ease, make any PCL application RAM-resident or even write self-modifying programs.

If you looked at C and couldn't see the emperor's new clothes then PCL is for you. PCL is much easier to learn, use and maintain. You'll find that it has more useful functions than C for real-life commercial or scientific programming.

And of course PCL will also run on AT/XT/PC's and most clones (just a bit slower). We are beta testing the OS/2 PCL implementation now.

PCL 3.0 costs just £195 + VAT.

To order call **CALEND**, London 894 7409 FAX-7550670
or write to

CALEND P.O. Box 94, Twickenham TW2 6DD, ENGLAND

A MESSAGE To OUR SUBSCRIBERS

FROM TIME TO TIME WE make the BYTE subscriber list available to other companies who wish to send our subscribers material about their products. We take great care to screen these companies, choosing only those who are reputable, and whose products, services, or information we feel would be of interest to you. Direct mail is an efficient medium for presenting the latest personal computer goods and services to our subscribers.

Many BYTE subscribers appreciate this controlled use of our mailing list, and look forward to finding information of interest to them in the mail. Used are our subscribers' names and addresses only (no other information we may have is ever given).

While we believe the distribution of this information is of benefit to our subscribers, we firmly respect the wishes of any subscriber who does not want to receive such promotional literature. Should you wish to restrict the use of your name, simply send your request to the following address.

BYTE MAGAZINE
ATTN: SUBSCRIBER SERVICE
P.O. Box 7643
TEANECK, NJ 07666-9866



An All-Purpose Multiuser Business System

According to Skillpace, its Tibus integrated multiuser software is an all-purpose business system that you can expand from a single workstation to supporting up to 300 users.

The system is based around a multiuser accounting package that runs under Digital Research's Concurrent DOS on IBM PC-compatible machines, but you can also expand it by networking machines together.

In addition to accounting, it provides word processing, invoicing, stock control, and other business functions that authorized users can access independently and simultaneously. It can hold accounting details for 1 million customers, suppliers, and transactions while archiving a similar number, and it can handle the accounts for over 100 companies each with up to 99 branches.

Tibus runs under Concurrent DOS 3.0 or higher on the IBM PC, XT, AT, and compatibles with 512K bytes of memory. A hard disk drive is recommended.

Price: £1250 for a single-user system; £2750 for 16 users.

Contact: Skillpace Ltd., 9 The Burdwood Centre, Station Rd., Thatcham, Berkshire RG13 4YA, U.K., (0635) 65226.

Inquiry 828.

Use the Graphics Tablet Mark III with Your Atari ST

A new driver for Cherry Electrical Products' high-resolution A3 Graphics Tablet Mark III (see What's New International, page 88A-20,

February BYTE) lets Atari ST users make full use of the object-oriented drawing and drafting software that is now available for that computer.

The driver makes the Mark III fully emulate the Atari mouse, so you can use it in applications like VIP Professional, Campus, Paintworks, Timeworks DTP, and other GEM-based graphics and publishing programs. The graphics tablet lets you use a stylus for better freehand drawing and to accurately digitize existing drawings. The Mark III becomes a desktop accessory under GEM, and it provides a menu of options that you can use to alter the scale and origin of the digitizer and to swap freely between tablet and mouse. The Atari ST driver software is free.

Price: £550 for the A3 Graphics Tablet Mark III.
Contact: Cherry Electrical Products Ltd., Coldharbour Lane, Harpenden, Hertfordshire AL5 4UN, U.K., (05827) 63100.

Inquiry 836.

Improved Programming for the Atari ST

HiSoft has added local labels and assemble-to-memory features to DevpacST version 2, a program for the Atari ST. The program integrates an editor, an assembler, and a debugger, with no disk accesses required to assemble, debug, or run a program.

You can generate executable code with the assembler, avoiding the link stage, and assemble the code directly into memory. Example source files include a desk accessory and a full GEM library.

The assembler can generate executable, GST, or DRI linkable code; directly in-

continued

The UniComal logo is positioned at the top center of the page. It features the word "UniComal" in a bold, sans-serif font, with a registered trademark symbol (®) to its upper right. The logo is set against a dark blue background that is part of a larger graphic of a torn paper effect. The left side of the page shows a chaotic pile of unlit matches, while the right side shows a neat grid of matches forming a window-like shape. The UniComal logo is placed at the top edge of this torn paper effect.

UniComal®

Basic »Structure«

UniComal »Structure«

*Send in the coupon below
for a free DEMO DISKETTE.
You can try the UniComal
and judge for yourself, if you
want to switch from Basic
or Pascal to UniComal.*

And don't feel you will have to »learn a new language«. UniComal simply incorporates the best features of each of these languages.

The revolution has already begun in Scandinavia and many large Common Market countries.

For Basic and Pascal programmers the switch to UniComal is painless. UniComal has its roots in these two languages.

And when you have mastered UniComal, your program development time will be cut in half or better!

Even for beginners, UniComal is one of the easiest languages to learn and to use, and one of the most powerful at the same time.

This is not just our opinion. Two popular European magazines (DOS and PC Magazine Plus, published in Germany) have reviewed UniComal in the autumn of 1987. Copies of these two articles, also available in English, are free for the asking. (***) You will also receive a free demo diskette, so you can try UniComal for yourself. (***) Just forward the attached coupon to UniComal A/S, 19 Tværmarksvej, DK 2860 Søborg, Denmark. We'll send you further information including a list of some of the hundreds of companies, schools and universities which use UniComal today.

Send the coupon today. It's your first step towards much easier professional programming.

Yes, please send me more information about UniComal, including two independent reviews (***) and a demo diskette(***) at no charge.

(please check)

- Send the German versions of the review articles.
- Please send the English translations.
- Send a list of references.
- Send additional documentation.

Name

Address

City

State

Zip

Clip out this coupon and send it in an envelope to:
UniComal A/S · 19 Tværmarksvej · DK-2860 Søborg · DENMARK
Fax +45 1 67 63 14

Denmark: IBM authorized PC dealers. Esselte Datasoft A/S, DK-2000 Frederiksberg. **France:** Langage et Informatique, F-31400 Toulouse. **Great Britain:** Research Machines Limited, Oxford OX2 0BW. **Holland:** Comal Software Groep, NL-2162 GK Lisse. **Iceland:** Haukar Ltd., IS-121 Reykjavik. **Ireland:** Branagan Business Supplies, IR-Dublin 1. **Micro Warehouse, IR-Dublin 14.** **Norway:** Tiki-Data A.S., N-0513 Oslo. **Schweizerland:** COMAL-SERVICE, CH-9203 Niederwil SG. **Spain:** Alis-ComTec, S.A. Informática, E-18080 Granada. **Sweden:** Förlagsgruppen AB, S-602 34 Norrköping. **North America:** Abacus, M1 49508. **W. Germany:** Comal Vertrieb, D-2270 Utersum Föhr.

YOU

as dealers are looking for a reliable supplier of computer and peripheral equipment

WE

are highly competitive wholesalers and can offer you computer products at prices you can't ignore

INTERESTED?

the simply write or phone for details of our price list

WIPPERMANN COMPUTER

Wholesale-Import-Export
Senefelderstrasse
4790 Paderborn, W Germany
Tel: (0 52 51) 51 31, open 9 am
Fax: (0 52 51) 59 844

TRY TODAY !! BUY IT !! THE FASTEST EXTRA 30 MAIN BOARD

Features:

- 286 XT Main Board (Extra 30)
- SI Test 7.7 Landmark Version 0.99 speed test 9 MHz
- 80286 CPU, 80287 option
- 1M RAM, 640k, 384k partition
- Disk Caching function on board
- Compatible with Model 30
- XT or 8 Bit I/O slot

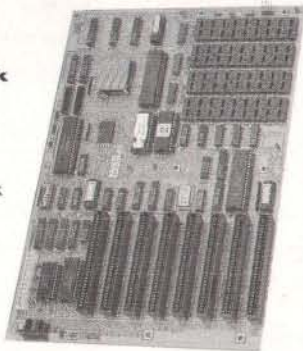

Whole Systems, Baby AT Board, Add on Card, are Available too.

MANUFACTURER & EXPORTER

PROTECH
SYSTEMS CO., LTD.

No. 559, Yung Chi Road, Taipei, Taiwan R.O.C.

Telex: 14266 PROTEK
Fax: 886-2-7862254
Tel: (02) 7863173-4, 7864731

Performance Index

Norton's Si Version 4,0



PROTECH EXTRA 30 SI 7.7

Si (DI) 3.3 Cache Mode

Model 30

P C AT

10MHz XT

WHAT'S NEW

INTERNATIONAL

clude binary files; and handle multiple sections and modules.

The debugger includes a flexible multiwindow display, a disassembler, and dual-screen display. You can use long symbols within the debugger and display your original source code. Breakpoints are available, as well as a run-until-condition feature for finding stubborn bugs.

Price: £59.95.

Contact: HiSoft, The Old School, Greenfield, Bedford MK45 5DE, U.K., (0525) 718181.

Inquiry 846.

Translate Your Pascal Programs to Ada

Traducta 2.0 from Euratec lets you translate Pascal programs into Ada. Since Pascal is almost a subset of Ada, the translation is mainly a substitution of keywords and structures, but Traducta can handle many of the more difficult cases.

The program can handle Pascal constructs that have no equivalent in Ada, such as the WITH keyword for accessing record components and the VAR parameter type. When you use variant records for type conversions in a Pascal program, Traducta translates them into instantiations of the generic Ada function unchecked_conversion. The program can also handle the illegal declaration order permitted in Turbo (and many other) Pascal programs and generates the correct order for Ada.

Traducta 2.0 runs on the IBM PC AT and compatibles, as well as the Apple Macintosh.

Price: \$395 U.S.

Contact: Euratec, 35 Rue Brunel, 75017 Paris, France, (33) 1-45-74-7094.

Inquiry 826.

European Consumer Data for Lotus 1-2-3 Users

Data from Euromonitor's "Consumer Europe" for the years 1982 through 1986 has been put onto 23 disks in a format that you can read straight into Lotus 1-2-3 or Symphony. A collection of information on consumer market sizes for 350 products in 17 Western European countries, the data is broken down into 16 categories, such as Food, Drink, Tobacco, Cosmetics, and Consumer Electronics, which you can purchase as separate units.

The disks contain pre-drawn graphs and pie charts on details such as market volume and size, and include a "What If?" facility for forecasting 5-year market volume.

"Consumer Europe 1988" runs under Symphony or Lotus 1-2-3 version 2.0 or higher on the IBM PC, XT, AT, and compatibles with DOS 2.0 or higher and 64K bytes of memory above the requirement to run Lotus 1-2-3. A hard disk drive is recommended.

Price: £2495 for the complete set; £725 for the four Food disks; £125 for the Tobacco disk; £325 for the two Consumer Electronics disks.

Contact: 4-5-6 World, Wellington House, Butt Rd., Colchester, Essex CO3 3DA, U.K., (0206) 579776.

Inquiry 996.

A Peripheral-Sharing System for the IBM PC

Two IBM PC computers can share printers and copy files with F2-Freeway, a software-based peripheral and file-transferring system.

The F2-Freeway Hub is a small black unit measuring 85

continued

Who else "tickles" your data?!



Beware your data!

Lock it up with

ELKEY-4

Industrial espionage, accidental loss of electronic data, or plain common sabotage by way of "viruses" planted into computer installations, are no longer fanciful figments of the imagination of science fiction writers.

They are current and everyday activities that are experienced in all western countries – serious reality, and a financial risk to anyone storing information on the rigid, floppy, or hard disks of Personal Computers.

Don't let it happen to you! Lock up your system with state-of-the-art electronic security. See how ELKEY-4, the Electronic Key, protects your installation.

Exclusive distributors welcome.

Circle 430 on Reader Service Card



Computer Elektronik Infosys AG, Oberdorfstrasse 11, CH-8953 Dietikon, Switzerland, Phone: +41-1-741 30 41

Computer Elektronik Infosys GmbH, Am Kümmerling 45, D-6501 Bodenheim, West Germany, Phone: +49-6135-770

Computer Elektronik Infosys of America, Inc., 512-A Herndon Parkway, Herndon, Virginia 22070, Phone: +1-703-425-2800

INTRODUCING BYTE's

Direct Response International Postcards

From the most prestigious microcomputer magazine comes a new and inexpensive direct response medium—a postcard advertising insert bound into the highly respected International Section of *BYTE Magazine*, called *BYTE's International Direct Response Postcards*.

Postcard ads provide a direct-response vehicle that encourages prospects to respond to offers for information as well as direct sales. A postcard ad is versatile because it allows you to test your product to potential buyers. That's because you can use your card to sell computer products, generate leads, conduct market research or sell books and periodicals. Each postcard is perforated so it can be easily torn out and returned directly to you without any intermediary—guaranteeing leads that are current and "hot."

Expand your horizons into this valuable marketplace.

The Pan-European marketplace is preparing to open up to greatly expanded trade in 1992 with the breaking down of trade restrictions. And *BYTE's International Direct Response Postcards* presents the perfect opportunity to test your product in this marketplace and to get your company positioned in the minds of the major buyers.

These unique advertising postcards which will be inserted into the International Section will reach 70,000 influential *BYTE* paid readers throughout Europe.

In Europe, contact:

Karen Lennie or
Roz Weyman (German-speaking)
at (01) 493-1451
McGraw-Hill Publications
34 Dover Street
London W1X 4BR
England

by 45 by 12 mm, which has two DB-25 (RS-232C) connectors (one male and one female) and a straight-through 8-conductor cable. You plug it into the COM1 port on each of the two computers, and it enhances communications by allowing the copy-protection mechanism to detect its presence.

Once you install the system, you can invoke the memory-resident windowing program, which gives you access to your own printer as well as to another computer's printer and files. The software runs under DOS 2.0 or higher and takes up 64K bytes of memory.

F2-Freeway operates at speeds of up to 115,200 bits per second and is compatible with the IBM PS/2 range of computers, as well as the IBM PC, XT, AT, and compatibles. You can copy files from 3½- and 5¼-inch 360K-byte, 720K-byte, and 1.44-megabyte floppy disks.

Price: \$159 Australian.
Contact: Program Development Systems, P.O. Box 1022, 55 Amberley Crescent, Dandenong 3175, Australia, 3-791-2255.

Inquiry 869.

Upgraded Tiny Master

Tiny Master, the user-supported inventory control program mentioned in *What's New International*, page 88A-30, June *BYTE*, has been extensively upgraded, thanks to feedback from *BYTE* readers.

The company has rewritten Tiny Master in Turbo Pascal 4.0, and it is now much faster. The new version features password protection, lets you cross-reference multiple inventories, and has data-file protection against system failure or power blackout. It also now supports most popu-

lar dot-matrix printers and the diacritical marks and accents required for printing in Arabic, Farsi, Thai, and other languages.

You can obtain a copy of Tiny Master II by sending a blank floppy disk and \$10 U.S. to cover postage and handling.

Contact: Jirayu Treeraprasert, Thai S.L. Co. Ltd., 629/3 Sathupradit Rd., Yannawa, Bangkok 10120, Thailand.

Inquiry 837.

Process Flowcharts and Organization Charts

You can create and edit flowcharts and organization charts with European Computing's Interactive EasyFlow, a flowchart processor for auditors and developers. The program uses international standard flowchart symbols and offers auditors the option of audit symbols and developers the option of CCITT SDL symbols. To simplify the drawing process, Interactive EasyFlow automatically performs line routing between boxes and supports the optional use of a mouse.

Interactive EasyFlow runs under DOS 2.0 or higher on the IBM PC, XT, AT, PS/2s, and compatibles with 320K bytes of memory. You can send your output charts to 9- and 24-pin dot-matrix printers, Hewlett-Packard-compatible laser printers, and plotters; it can also interface to Aldus PageMaker and AutoCAD.

Price: £150.
Contact: European Computing, 57 West End Ave., Harrogate HG2 9BX, U.K., (0423) 509350.

Inquiry 999.

continued

Ada[®]

The Ada[®] world just changed. Again.

Meridian Europe continues its tradition of Ada "firsts" by introducing a powerful new set of integrated software development tools.



AdaVantage Optimizing Ada Compiler

Available for the APPLE Macintosh and the IBM PC and compatibles. An exceptionally fast validated Ada compiler that for the first time brings a true world-class production quality Ada compiler to your desktop personal workstation.



Ada Run-Time Customization Library

For preparation of Ada application programs for execution on embedded systems based on 80X86 or other operating systems. The Library is a collection of Ada source files, batch files, and documentation that define the customizable, system-dependant components of the AdaVantage Run-Time System.

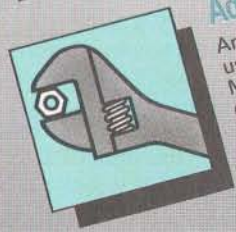

AdaVantage Debugger

An interactive source-level debugger for use with programs written using the Meridian AdaVantage compiler. The debugger allows the programmer complete control over the execution of an Ada program in high-level Ada terms - no knowledge of the underlying machine architecture is required. The debugger supports break points, subprogram traces, single-stepping, call backtraces, and full Ada reference syntax.

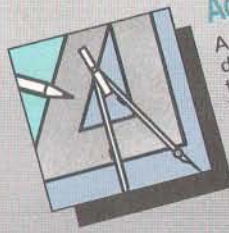

Ada Designer

A collection of tools supporting the design, programming, and the documentation phases of the software life cycle. Tools include a structured editor/synthesizer coupled to a text editor/incremental editor for design languages, a program deviation processor that guarantees your design is always in sync with your implementation, and a structured documentation generator.



Ada Developer Interface

A powerful interactive screen-orientated interface to the Ada library dependency information. Includes built-in operations to edit, "pretty print", compile, and link any Ada library unit. Configuration file allows user customisation of all operations and displays.



Ada Configuration

The compilers all run in a standard PC configuration (min. 640 K of memory and hard disk) or the Macintosh Plus, SE, II, and hard disk.

For more information call Meridian Europe or one of the distributors listed below.

“AdaVantage... is an Ada software milestone.”

PC Week



- Pixisstr. 2 · D-8000 Munich 80 · W-Germany · +49-89-9 2100 80
- France: European Advanced Technologies · 35, rue Brunel · F-75017 Paris · Tel.: 45747094
- Germany: GSE Software Engineering · Postfach 86 03 49 · D-8000 München 80 · Tel.: 0 89-92 10 08 27
- Sweden: Sypro i Arboga AB · Paradisgränd 6 · S-73200 Arboga · Tel.: 05 89-128 10
- United Kingdom: High Integrity Systems · Astra Centre · Edinburgh Way · Harlow, Essex CM 20 2BE · Tel.: 0279-45 00 00

The information contained herein is subject to change without notice. Ada is a registered trademark of the U.S. Government (AJPO), AdaVantage and AdaDesigner are trademarks owned by the respective manufacturers. Meridian Europe is a trademark of Meridian Software Systems, Inc. licensed to GSE

Circle 439 on Reader Service Card

Looking for Distribution in W. Germany?

Datronic GmbH

supports all major PC/XT/AT/386 related Hardware Products.

Founded in Jan. 1984 Datronic now serves over 7,500 Retailers and Software houses with High Quality PC Components and complete Systems. Among our Distribution Contracts are: **Dysan**, **Canon Laserprinters**, **Western Digital Peripherals**, **Fujitsu** and **Tandon Hard disks and Floppy drives** and many more.

Contact us today for professional Distribution and technical Support of your PC-related Products.

Datronic GmbH

Frankfurter Str. 1-5, D 6236

Eschborn/Frankfurt, West Germany

Tel.: 06196-41723

FAX: 06196-481629

Subscription Problems?



We want to help!

If you have a problem with your BYTE subscription, write us with the details. We'll do our best to set it right. But we must have the name, address, and zip of the subscription (new and old address, if it's a change of address). If the problem involves a payment, be sure to include copies of the credit card statement, or front and back of cancelled checks. Include a "business hours" phone number if possible.

BYTE

Subscriber Service

P.O. Box 7643

Teaneck, NJ 07666-9866



WHAT'S NEW

INTERNATIONAL

High-Resolution Graphics on Your IBM PS/2

The Artist 10 MC is a high-resolution graphics card for the IBM PS/2s that uses the Micro Channel architecture bus. The card is based on the Hitachi ACRTC graphics controller chip. It features a noninterlaced resolution of 1024 by 768 pixels and gives you a choice of 256 colors from a palette of 16.7 million shades.

The card has a maximum bandwidth of 64 MHz and a variable scan rate of 31 to 50 kHz, so you can use it with a range of monitors. Driver software is available for popular CAD, desktop publishing, and terminal-emulation programs. A special driver for AutoCAD, called Artist GT, gives you instant redraws, bird's-eye views, zooming, and concurrent panning at up to 25 times the speed of a normal PS/2. The company claims that Artist 10 MC completed a benchmark test involving a 361K-byte street map in 4 seconds, as opposed to 1 minute, 18 seconds for the standard PS/2 display.

Price: £2695, including one software driver of your choice.

Contact: Control Systems Europe, Victoria House, 28-38 Desborough St., High Wycombe, Buckinghamshire HP11 2NF, U.K., (0494) 26211.

Inquiry 839.

Science and Engineering on Your IBM PC

For scientific and engineering programs, Cesium claims its Scientific Accelerator coprocessor and memory system gives you the power of a minicomputer or mainframe computer on your desktop.

The programs migrate from networked minicomputers or mainframe computers to run on your IBM PC, XT, AT, or compatible computer, in which you have installed the accelerator board. The board contains a 32-bit VLSI reduced-instruction-set-computer microprocessor with an on-chip 64-bit floating-point unit, which gives you a processing speed of 1 million floating-point operations per second and integer calculations at 10 million instructions per second. For solving large problems, 16 megabytes of on-board dynamic RAM is available for programs and data.

You can port your own FORTRAN or C programs to run on the Cesium system. FORTRAN-77 and C development utilities are available, which produce executable code from your source code. You then load the executable code onto the system and run it from the host computer. FORTRAN and C cross-development utilities are available for VAX/VMS and Sun-3 systems. Recompilation and migration to the system is fast and easy, according to Cesium.

Other features include error-checking in hardware, selectable interrupts and direct-memory-access lines, address-exception checking, and interrupt-driven error reporting.

Two versions of the Cesium Scientific Accelerator are available: a FORTRAN system and a C system. The interface comes with a standard IBM PC expansion slot connector that runs under MS-DOS 2.0 or higher.

Price: £8500 each.

Contact: Cesium Ltd., Southgate, Whitefriars, Lewins Mead, Bristol BS1 2NT, U.K., (0272) 277409.

Inquiry 862.

continued

CADcontroller™

The Affordable Resolution



This Multi-Function Graphics Card Combines The Features Your CAD System Requires.

Increase Your Productivity. *CADcontroller* generates color graphics of up to 1024x768 non-interlaced resolution, producing sharp, flicker free images that are easy to see. Its advanced CRT controller will speed up your work by drawing lines at a rate of 1 million pixels/second.

Expand Your System. A built-in COM port is convenient for connecting peripherals. As an added feature, *CADcontroller's* serial port can power our Micro DIGI-PAD digitizer directly, eliminating the external power supply.

Improve Your Performance. Most CAD programs work best with extra memory, allowing quick access to programs and drawing files. For this purpose, *CADcontroller* can have an optional 1 megabyte of extended RAM on board.

Choose Your Monitor. *CADcontroller* is compatible with both high resolution monitors and popular, low cost, medium resolution monitors such as the NEC MultiSync®. We designed it to be versatile so that you can choose the resolution, bandwidth and output mode your monitor requires.

The Price? So good there's no need to look elsewhere.

Call GTCO For A Brochure On *CADcontroller* And All Of Our Graphic Products.

GTCO Corporation, 7125 Riverwood Drive, Columbia, MD 21046 Phone: (301) 381-6688 Telex: 898471 Fax: (301) 290-9065

An IBM PC-to-Transputer Link

The PC-TPLA card provides two 10-megabit-per-second transputer links. The half-size card for the IBM PC, XT, AT, PS/2 Model 30, and compatibles contains two INMOS Link-Adapter chips. The chips let external transputer-based systems talk to the computer's hardware by translating the high-speed serial stream from the transputers into parallel bus signals.

Price: £190.

Contact: U-Microcomputers Ltd., 12 Chatham Ct., Calver Rd., Winwick Quay, Warrington, Cheshire WA2 8RF, U.K., (0925) 54117.
Inquiry 840.

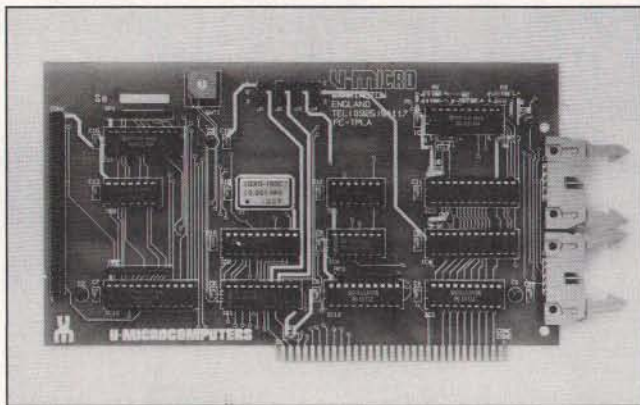

U-Micro's PC-TPLA card with INMOS Link-Adapter chips.

A Macintosh Version of db_Vista

Systemstar Ltd. offers Raima's db_VISTA III database development environment for the Macintosh. The program, which was previously available for the PC-

DOS, Unix, and VMS operating systems (see What's New International, page 88A-28, April BYTE), uses a network database architecture in which you can develop very complex applications with a minimum of redundant data duplication.

Features include db_QUERY, an SQL-based

query and report-writing tool; db_REVERSE, another tool that lets you alter the structure of a database without loss of data; automatic database recovery; and the ability to access multiple databases simultaneously from one application.

All db_VISTA III applications are written in C, and the current Mac release supports the MPW C Compiler; a version to support Lightspeed C is in preparation. No royalty is charged on applications using the run-time package.

Price: £445 for a single-user object code version with 60 days free technical support.
Contact: Systemstar Ltd., 1-3 Parliament Square, Hertford SG14 1EX, U.K., (0992) 500919.

Inquiry 835.

continued

Computers For The Blind

Talking computers give blind and visually impaired people access to electronic information. The question is how and how much?

The answers can be found in "The Second Beginner's Guide to Personal Computers for the Blind and Visually Impaired" published by the National Braille Press. This comprehensive book contains a Buyer's Guide to talking microcomputers and large print display processors. More importantly it includes reviews, written by blind users, of software that works with speech.

This invaluable resource book offers details on training programs in computer applications for the blind, and other useful information on how to buy and use special equipment.

Send orders to:

National Braille Press Inc.
88 St. Stephen Street
Boston, MA 02115
(617) 266-6160

\$12.95 for braille or cassette, \$14.95 for print. (\$3 extra for UPS shipping)

NBP is a nonprofit braille printing and publishing house.

BYTE's
International
Direct
Response
Postcards

Now you can order the advertised products and services *directly from the sellers!* No middleman is involved.

Just fill out the postcards of interest to you, affix postage and place in the mail.

Or, for even faster response, call the telephone numbers indicated on the cards.

If you have a product or service that you would like to advertise to European BYTE readers, contact Karen Lennie for information at BYTE's London office: 01-493-1451.



Get High-Tech Data Protection With Verbatim!

Count on Verbatim for exceptional performance! Only Verbatim offers exclusives like DuPont Teflon® coated **DataLifePlus Diskettes**, and **DataLife Diskettes** with DataHold anti-static liners to safeguard against data loss. Verbatim **DataLife Data Cartridges** provide premium performance and durability to help keep data more secure!

Return this card for a **FREE** catalog from **Azerty**, your complete source for computer supplies, or call Patty Donati (716) 691-6724, Ext. 351 to place your order today!



INFORMATION PROCESSING PRODUCTS

135 Pineview Drive, Tonawanda, New York 14150, U.S.A.
(716) 691-6724, Ext. 351

Name _____
Company _____ Title _____
Address _____
City _____ Country _____ Postal Code _____
Telephone _____ FAX _____
Telex _____ Dealer End User

(Please Print Clearly or Attach Business Card)

Generate High-Quality Leads and Direct Orders with BYTE's International Direct Response Postcards

If you have a computer product or service and would like to reach BYTE's European audience, why not consider a postcard advertisement such as this one. These postcards in the International Section of BYTE will be seen by the most influential and responsive group of computer buyers throughout Europe.

For more information on this exciting new program, fill out and mail this postcard or call Karen Lennie in BYTE's London office at 01-493-1451.

Yes, I would like more information on the International Direct Response Postcard program.

Name _____
Title _____
Company _____
Address _____
City/Code _____
Country _____

NEW MAGAZINE FOR SUPERIOR BUS SYSTEMS

If you are interested in the **VMEbus**
or the **Multibus**
or the **S-100 bus**

there is now a great new journal for you:

SUPERMICRO
JOURNAL OF VME, MULTIBUS, AND S-100 SYSTEMS

This new magazine covers both the technical and the practical aspects of each of the above IEEE standard buses. It describes new products, evaluates new add-on boards, helps in product selection, and has articles on board-level system integration.

SUPERMICRO is printed in color on high-quality paper and has over 100 pages. For information on subscribing, please see the other side of this card.

Place
Stamp
Here



AZERTY

INFORMATION PROCESSING PRODUCTS

c/o BYTE/McGraw-Hill
34 Dover Street
London W1X 4BR
England

Attn: Karen Lennie

Place
Stamp
Here

McGraw-Hill Publications
BYTE Magazine
Karen Lennie
34 Dover Street
London W1X 4BR
England

HOW TO SUBSCRIBE TO SUPERMICRO:

1. Write clearly or type your name and address in the rectangle below.
2. Decide if you want to subscribe for 1 year (US\$40) or for 2 years (US\$72). Each year includes 4 issues plus 1 directory of board-level products for the VMEbus, the Multibus I and II, and the S-100 bus. The above rates also include airlift to Europe and ground distribution within Europe.
3. Return this card with payment in U.S. funds. If you would like to charge to your VISA, MasterCard, or Am Express, please enter Card Number here: _____

Expiration date: _____ Signature: _____

★ Mail to: SUPERMICRO, PO Box 50777, Provo, UT 84605, USA

4. OUR GUARANTEE: If after receiving your first issue, you are not satisfied, simply write to us and request a cancellation of your subscription. We will keep US\$10 to cover the expense of mailing your first issue, but we will refund the balance of your payment by international money order or credit your charge card.

NAME: _____

ADDRESS: _____

BYTE's
International
Direct
Response
Postcards

Now you can order the advertised products and services *directly from the sellers!* No middleman is involved.

Just fill out the postcards of interest to you, affix postage and place in the mail.

Or, for even faster response, call the telephone numbers indicated on the cards.

If you have a product or service that you would like to advertise to European BYTE readers, contact Karen Lennie for information at BYTE's London office: 01-493-1451.



BYTE's
International
Direct
Response
Postcards

Now you can order the advertised products and services *directly from the sellers!* No middleman is involved.

Just fill out the postcards of interest to you, affix postage and place in the mail.

Or, for even faster response, call the telephone numbers indicated on the cards.

If you have a product or service that you would like to advertise to European BYTE readers, contact Karen Lennie for information at BYTE's London office: 01-493-1451.



The Power To Create Your Own Program — Without Programming!

With the revolutionary new Matrix Layout, you can quickly and easily write programs simply by painting and drawing an icon-based flowchart. You don't need to write even one line of program code, because Layout does it for you, in your choice of Turbo Pascal, Turbo C, Lattice C, Microsoft C, Quick Basic, or Stand Alone. Add Macintosh-like windows, buttons, icons, dialog boxes, beautiful graphics, and stunning text. Include sophisticated Hypertext functionality and automatic mouse support in every program you create. Your finished programs will be so fast, even on a standard PC, you'll have

to see them to believe them!
 The cost for this incredible CASE tool for the PC and PS/2? Only \$149.95 for the entire package, which includes a professional Paint program, HelpMaker, Desktop, and a 30-day, money-back guarantee. Still don't believe it? Then we'll send you a VHS demonstration tape for only \$9.95.
Call 1-800-533-5644 (In Massachusetts, call 617-567-0037). Or send this return card today (see reverse for order information).

M A T R I X
LAYOUT

For your own subscription to complete this card and post.

BYTE



Subscription Rates

Enter my one year subscription (12 issues) as indicated below:

- £46 Sterling, air delivery to Europe. (Includes USSR, Turkey and Cyprus)
- £21 Sterling, fast surface delivery to Europe.

Payment or credit card information must accompany your order.

Please allow 6-8 weeks for processing. Thank you.

Name _____
 Address _____
 City _____ Code _____
 Country _____
 Payment enclosed. (All cheques must be payable in pounds sterling.) IBJ5104
 Charge to my Access EUROCARD VISA MasterCard American Express
 Account # _____ Expiration Date _____
 Signature _____

4.00 U.S.
 PER DISK
 Ten or More

Software Excitement's User-Supported Collection
TOP 40 DISKS
 For IBM PCs and Compatible Computers

5.00 U.S.
 PER DISK
 Less Than Ten

BUSINESS/ACCOUNTING/HOME FINANCE

- EZ-Forms**—Makes generating any type of business form easy!
- PC-General Ledger**—This is a complete GL package.
- Stock Charting System**—Creates high/low/close and moving-average charts for all your stocks!
- PC-Calc+**—Has the features of the big-name spreadsheets. You can import 1-2-3 worksheets and print impressive graphs (3 disks)
- Home Inventory**—Keeps track of everything you own!
- Small Business Accounting**—A simple, yet complete, accounting package—perfect for non-manufacturing businesses
- Your Financial Consultant**—This easy-to-use package with on-screen help keeps track of your personal finances.

WORD PROCESSING and DATABASE

- PC-Write**—A very popular and full-featured word processor that has many features and is very easy to learn and use (2 disks)
- Letter Writer**—Makes letter writing easier and more fun!
- New York Word**—Everything you need including mail-merge, split-screens, macros, "expression" checking, and spell-checking.
- Slic-Works**—A very popular all-in-one information filter, letter writer, and telecommunications program which is very easy to use
- PC-File+**—The most powerful and complete DBase (3 disks)
- Mail Master**—Full-featured mail list manager and label printer
- DBase Publisher**—Prints and maintains a 1-1000 item catalog

UTILITIES and APPLICATIONS

- Master Keys**—Disk utilities like Norton Utilities, only better!
- Banner Maker**—Makes great banners! Also a Sideways utility
- Desk Mates**—Disk full of helpful Sidekick-like desk accessories
- Auto Menu**—Makes using the computer more convenient and easier because all of your programs can be accessed from a menu!
- Piano Man**—Play and edit music with your computer keyboard or play the sample songs. Fun and educational for kids and adults!
- Fast Copiers**—Several SUPER-FAST disk and file copiers

EDUCATION

- Facts**—Teaches kids the states, capitals, presidents, etc.
- Typing Tutor**—improve your skills with this handy teacher
- Lotus Learning System**—Makes it easy to master 1-2-3. Lotus 1-2-3 or PC-Calc are not required, but recommended (2 disks)
- Geography**—Make learning fun with this geography trivia game
- BibleQ**—Test your Bible knowledge with this fun Bible IQ tester!
- Spanish**—Beginning Spanish for the student or traveler
- Math Tutor**—A fun way for kids 5-12 to learn or improve their math skills. Can be user-modified to run specific tutorials
- Computer Tutor**—If you are a new user or computer novice, THIS IS WHAT YOU NEED! Learn in a fun, pressure-free environment

GAMES

- Striker**—Helicopter attack game. A great RISK game, too!
- Diamond Master Baseball**—Test your knowledge of the game with this realistic statistical approach to baseball play
- Pinball**—Play this great pinball simulation. Save quarters! *
- Q-Bert**—Play the famous arcade hit on your computer *
- Backgammon**—Play against the computer. Centipede, too! *
- Wheel of Misfortune**—Play the popular TV game show anytime on your computer. Up to 6 players
- Adventure Addition**—Five great text-adventure games
- Trivia Towers**—An excellent trivia game that can be played by 2 to 4 people. Test your knowledge in many topics (2 disks)
- Kid Games**—Several fun games designed to make learning fun!
- Master the Market**—A great stock market simulation game. This is much better than the popular Millionaire game *
- Monopoly**—Great color and sound! *
- JetSet**—A jet flight-simulator

PLEASE NOTE

Most GAMES disks contain several games—listed are the highlights. Disks followed by an * require a color system (CGA or EGA)

Name _____

Address _____

City _____

State, Zip _____

Send me Matrix Layout @ \$149.95

Send me the video tape @ \$9.95

Please charge my Visa

MasterCard Check enclosed.

Acct. # _____

Expiration date _____

For Continental Europe Contact:

Matrix Software Technology NV
Geldenaaksebaan 476
3030 LEUVEN
BELGIUM
Tel. 016/20.20.64
Fax 016/20.77.10
Telex 23.692

For United Kingdom Contact:

Matrix Software Technology Ltd.
Matrix House, Derriford Business Park
Derriford, Plymouth, Devon PL6 5Q2
England, Tel (0752) 790363

PLACE
STAMP
HERE

BYTE

McGraw-Hill Information Systems
McGraw-Hill House
Maidenhead, Berkshire SL6 2QL
England

Attn: International Circulation Department

- Lowest Prices •
- Highest Quality •
- Same-Day Shipping •
- Money-Back Guarantee •
- Very Easy To Use •
- Instructions and Documentation •

(503) 664-1364

Only the **BEST** Software
For IBM PCs and Compatibles

PLACE
STAMP
HERE

Software Excitement!

c/o BYTE McGraw-Hill
34 Dover Street
London W1X 4BR
Attn: Karen Lennie

Free Catalog with Order or Request 3.5" Disk Format—Add \$2.00 per Disk

Name _____	Disk Size <input type="checkbox"/> 5¼" <input type="checkbox"/> 3½" (+\$2.00 U.S.)
Address _____	
City _____	Disks Ordered _____ x Cost/Disk _____ \$ _____
Country _____	SHIPPING (International Air Mail) \$ 5.00
Visa/MC _____ Exp. _____	
Signature _____	TOTAL Enclosed/Charged/COD..... \$ _____

**BYTE's
International
Direct
Response
Postcards**

Now you can order the advertised products and services *directly from the sellers!* No middleman is involved.

Just fill out the postcards of interest to you, affix postage and place in the mail.

Or, for even faster response, call the telephone numbers indicated on the cards.

If you have a product or service that you would like to advertise to European BYTE readers, contact Karen Lennie for information at BYTE's London office: 01-493-1451.





Above & beyond the call.

Software

Word Processing/ Desktop Publishing

Byline	\$ 199
Microsoft Word	\$ 219
Multimate Advantage-II	\$ 269
Lotus Manuscript	\$ 339
Office Writer/Speller	\$ 249
Pagemaker 3.0	\$ 549
PFS: Prof Write	\$ 119
Publisher's Type Foundry	\$ 259
Sprint	\$ 129
Ventura Publisher	\$ 519
Word Perfect 5.0	\$ 229
Wordstar Pro 5.0	\$ 259
Wordstar 2000 + 3.0	\$ 229
Xywrite III +	\$ 229

Database Systems

Clipper	\$ 449
DBase III Plus	\$ 389
Dataease	\$ 389
Data Perfect	\$ 299
Foxbase +	\$ 199
Paradox 2	\$ 429
PFS: Prof File	\$ 149
Q&A	\$ 209
R Base for DOS	\$ 479
Reflex	\$ 99

Spreadsheets/ Integrated Packages

Javelin +	\$ 169
Lotus 1-2-3	\$ 309
Lotus Agenda	\$ 269
Lotus Hal	\$ 49
Lucid 30	\$ 99
Microsoft Excell	\$ 319
Microsoft Works	\$ 139
Quattro	\$ 129
Smart System	\$ 449
SuperCalc 4	\$ 299
Symphony	\$ 449

Communications

Carbon Copy +	\$ 119
Crosstalk XVI	\$ 99
Crosstalk MK 4	\$ 125
Procom +	\$ 59
Relay Gold	\$ 149
Smarterm (Persoft)	\$ Call
Smartcom III	\$ 149

Statistics

SPSS/PC +	\$ 699
Statgraphics 2.6	\$ 479
Systat 4.0	\$ 519

Desktop Environments

MS Windows 286	\$ 69
Sidekick Plus	\$ 129

Graphics

Chartmaster	\$ 219
Design CAD	\$ 159
Diagraph	\$ 259
Diagram Master	\$ 199
Freelance Plus	\$ 329
Graph Plus	\$ 259
Micrografx Designer	\$ 449
Harvard Graphics	\$ 279
MS Chart	\$ 269
PC Paintbrush Plus	\$ 89
Picture Perfect	\$ 199
Presentation Pak	\$ 349
Publishers Paintbrush	\$ 159

Project Management

Harvard Total	\$ 369
Project Manager II	\$ 329
Microsoft Project 4.0	\$ 289
Superproject Plus	\$ 289
Timeline 3.0	\$ 349

Languages/Utilities

Fastback +	\$ 99
Lattice C	\$ 229
Norton Advanced	\$ 79
Microsoft C	\$ 299
Mace Utilities	\$ 65
MS Fortran 4.0	\$ 299
Quick Basic/Quick C	\$ 69
Turbo Basic/Turbo C	\$ 65
Turbo Pascal	\$ 65

Accounting

AccPac BPI	\$ 279
Great Plains	\$ 499
Peachtree Comp II	\$ 159

Hardware*

Computers

AST Premium 286	\$ Call
Samsung	\$ Call
Toshiba Lap Tops	\$ Call

Multifunction Boards

AST Advantage	\$ 329
Premium (512K)	\$ 329
AST 6 Pak Plus (64K)	\$ 129
AST Rampage/2 (OK)	\$ 189
AST Rampage 286	\$ 419
Everex RAM 4000	\$ 299
Inboard 386AT	\$1050
Inboard 386 PC	\$ 750
Intel AboveBoard	\$ Call

Display Boards

ATI EGA Wonder +	\$ 229
Hercules Network	\$ 349
Card Plus W/Tops	\$ 349
Paradise VGA Plus	\$ 259

Modems

Hayes 1200/1200B	\$ 299
Hayes 2400/2400B	\$ 449
Practical Modem 1200 Int.	\$ 79
US Robotics 2400B	\$ 159
Ventel 2400/2400B	\$ 389
Ventel 2400/2-PS2	\$ 299

Networking

Arcnet Board—SMC	\$ 149
Novell Adv. Netware 286	\$1799
Novell ELS	\$ 389
Tops For DOS	\$ 119

Emulation Boards

AST 5251-11 +	\$ 629
Irma/2 PCA/MCA	\$ 725

Monitors

Amdek 410A	\$ 149
NEC MultiSync II	\$ 629
NEC Multisync GS	\$ 199
Princeton HX-12 +	\$ 439
Princeton MAX-12E	\$ 149
Samsung Color	\$ 239
Zenith ZVM 1490	\$ 679

Printers/Plotters

Dest PC Scan 2020	\$1499
Epson FX-286E	\$ 499
Epson FX-1050	\$ 549
Epson LQ1050	\$ 819
HP 7475A	\$1499
HP Laserjet II	\$1795
LQ-500	\$ 379
NEC 5300	\$ 749
NEC P2200	\$ 369
Okidata 320	\$ 375
Okidata 321	\$ 519
Okidata 393	\$1050
Okidata 293E	\$ 675
Panasonic	\$ Call

The Complete Hand Scanner

Toshiba P321SL	\$ 589
Toshiba P341SL	\$ 769
Toshiba P351SX	\$1175

Mass Storage/Backup

Bernoulli II Dual	\$1799
Irwin Tape Drives	\$ Call
Mountain 40MB Int Tape	\$ 389
Plus HardCard 20MB	\$ 519
Plus HardCard 40MB	\$ 719
Seagate ST251-1	\$ 529
Seagate ST 225 W/int	\$ 289
Seagate ST238 W/int	\$ 319
Sysgen Bridge	\$ 299

Input Devices

Keytronics KB 101	\$ 109
Logitech Hi-res Mouse	\$ 99
Microsoft Mouse	\$ 109
PC Mouse w/Paint	\$ 99

Accessories

Curtis Ruby	\$ 59
DataShield S-100	\$ 69
Logical Connection	\$ 329
Masterpiece Plus	\$ 125
256K Ram Set	\$ Call
8087 Math Chip	\$ 119
80287-8/80287-10	\$289/\$339
80387-16/80387-20	\$529/\$775

*CALL FOR SHIPPING COST

ATTENTION CORPORATE BUYERS!!

Join over 1000 major corporations and institutions who have selected **SOFTLINE** as their primary vendor. Here's why:

- **Wide Selection**—We carry over 1000 "corporate" titles. We will assist you to source those difficult requests.
- **Low Price** Our motto has always been "Sample our Service. Price shall never be an issue."
- **Fast Delivery**—For those last minute rush orders, we offer convenient overnight delivery.
- **P.O.'s, of Course!!** We accept purchase orders from qualified organizations. Ask about our customized purchasing programs for volume buyers.

ATTENTION INTERNATIONAL BUYERS!!

We process export orders to thousands of companies worldwide. Convenient TELEX and FAX facilities available.

Contact: **Fay Chayne**, Intl. Sales Manager.

Celebrating 5 Years of Excellence

1-718-438-6057

Customer Service Hours: 9 AM—5 PM, Mon.—Fri.

Contact: **Fay Chayne** -Intl. Sales Mngr.



Softline

1333 60th Street
Brooklyn, NY 11219
TELEX: 627-30170 or 910-240-3918
FAX: (718) 438-2315



Buy with

Confidence

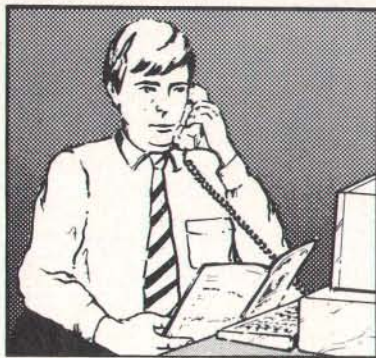

In an effort to make your telephone purchasing a more successful and pleasurable activity, The Microcomputer Marketing Council of the Direct Marketing Association, Inc. offers this advice, "A knowledgeable buyer will be a successful buyer." These are specific facts you should know about the prospective seller before placing an order:

Ask These Important Questions

- How long has the company been in business?
- Does the company offer technical assistance?
- Is there a service facility?
- Are manufacturer's warranties handled through the company?
- Does the seller have formal return and refund policies?
- Is there an additional charge for use of credit cards?
- Are credit card charges held until time of shipment?
- What are shipping costs for items ordered?

Reputable computer dealers will answer all these questions to your satisfaction. Don't settle for less when buying your computer hardware, software, peripherals and supplies.

Purchasing Guidelines

- State as completely and accurately as you can what merchandise you want including brand name, model number, catalog number.
- Establish that the item is in stock and confirm shipping date.
- Confirm that the price is as advertised.
- Obtain an order number and identification of the sales representative.
- Make a record of your order, noting exact price including shipping, date of order, promised shipping date and order number.

If you ever have a problem, remember to deal first with the seller. If you cannot resolve the problem, write to MAIL ORDER ACTION LINE, c/o DMA, 6 E. 43rd St., New York, NY 10017.

This message is brought to you by:

the MICROCOMPUTER
MARKETING COUNCIL
of the Direct Marketing
Association, Inc.
6 E. 43rd St.,
New York, NY 10017

MMCG
MICROCOMPUTER
MARKETING COUNCIL
of the Direct Marketing Association, Inc.

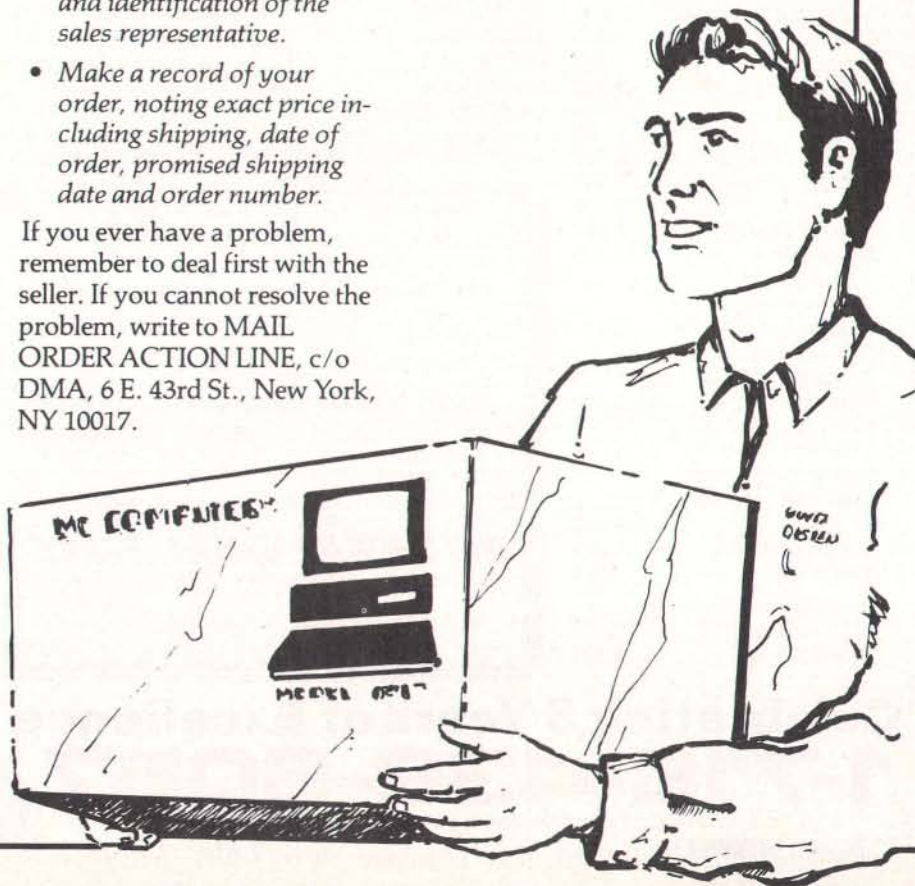

International Edition

S-100

"THE PC PEOPLE"

SINCE 1977

PC COMPATIBLE SYSTEMS



ARC

ARC Model 10 XT - 8088-10 MHz, 640K RAM, 360K floppy, MS-DOS 3.3..... CALL

ARC Turbo 12 - 80286-12.5 MHz 1 wait, 1Mb RAM, 1.2 Mb floppy, MS-DOS 3.3 CALL

ARC Options

AT-Style Keytronics keyboard \$ 59
RT-Style 101 Keytronics enhanced keyboard \$ 69
Add-In Boards..... See Modems & Boards
Monitors..... See Monitors
Drives..... See Drives

AST RESEARCH INC.

Premium/286 - Model 80.....CALL
Premium/386 - Model 300.....CALL

ZENITH

SupersPort - Dual 720K floppy, 640K, 80C88-8 MHz CPU, detach. battery pak, back-lit superwist screen 640x200, RGB color connector for external monitor, clock, ser., para. ports, ext. expansion bus (optional), only 9.7 lbs. \$1,689

With 20Mb hard drive, 720K floppy \$2,489

Zenith SupersPort 286 - 1.44Mb floppy, 20Mb hard dr., 80C286-12MHz, 1Mb, 640x400 8 shades of grey, C,S,P, RGB ports, 14 lbs. with battery pak. \$3,598

MONITORS & TERMINALS

CTX

CTX 2400 white flat \$119
EGA tilt 'n' swivel, 14" mon ... \$359
14" tilt 'n' swivel color hi-res... \$239
12" TTL tilt 'n' swivel amber .. \$ 79
Soft White flat screen..... \$ 89

TATUNG

CM-1495 OmniScan 14" Multi-freq., 800x600, VGA,EGA,CGA, MACII, Trn'S, VGA card..... \$729

MDS

"The Genius" FULL PAGE for PC/XT/AT.....CALL

MONITERM

.....CALL

NEC

MultiSync II (1402)..... \$635

WYSE

WYSE 50 \$389 / WYSE 60 \$425
WYSE WY700 1280 x 800... \$749

XTRON

XTRON - Futuristic and flat, for you. With dual mono, EGA, VGA & Multisync models CALL

ZENITH

ZCM-1490 VGA..... \$675

POWER ACCESSORIES

American Power Conversion

330XT \$ 295
450AT \$ 425
520 ES \$ 495
800RT w/UPS I/F. \$ 795
1200VX w/UPS I/F. \$ 975
Interface Cable \$ 25

Novell U.P.S. Monitor Board Compatible!
* 220 Volt Models Available *

NETWORKING

4-User NOVELL Network System Server/Work Station:

- ◆ American Research (ARC) - 12.5MHz, 1 wait, 80286, PC/AT 210W power supply, 1 serial, 2 parallel ports, monitor, 1.2Mb floppy, 2Mb RAM, 71Mb hard drive, 60Mb tape drive.
- ◆ American Power Conversion 520 Watt S.P.S.
- ◆ NOVELL ELS NetWare 286 Level 1 (4-users) Network set-up is Menu Driven
- ◆ 4 ArcNet cards, 200' cable, 4-port passive hub
- ◆ 3 ARC™ M10 XT's - Each includes: 640K, 4.77/10 MHz, 8088-1 CPU, MS-DOS 3.21, RT-style keyboard, amber tilt 'n' swivel monitor.

List Price \$13,995- Your Cost \$7,895
Lease from \$199. per month.

PC COMPATIBLE SOFTWARE*

- Data Base Management
- Ashton-Tate dBase III Plus.....\$368
 - PFS: Professional File.....\$119
 - WordTech DBXL (dBASE 3) "Diamond".....\$115
- Communications
- Carbon Copy Plus (Meridian).....\$109
 - Crosstalk XVI (Microstuf).....\$ 98
- Word Processors
- NewWord (WordStar 4.0 clone).....\$ 98
 - WordStar 4.0.....\$228
 - MicroSoft Word.....\$235
 - Multimate Advantage II.....\$278
 - PFS: Professional Write.....\$105
 - Word Perfect.....\$239
- Integrated / Spreadsheets
- Enable 2.0 (software group).....\$369
 - Framework III (Ashton-Tate).....\$399
 - Lotus 1-2-3.....\$295
 - Multiplan 3.0.....\$115
 - PFS: First Choice.....\$ 85
 - PFS: Professional Plan.....\$ 58
 - Borland Quattro.....\$155
 - Symphony (Lotus).....\$438
- Desktop Publishing
- PFS: First Publisher.....\$ 69
 - PFS: Art Gallery.....\$ 69
 - Xerox Ventura 1.1.....\$489
 - Aldus PageMaker/PC 3.0.....\$549
- Graphics & Mice
- Harvard Graphics (for Lotus 1-2-3).....\$248
 - IMSI OptiMouse Serial.....\$ 88
 - IMSI Genius Mouse Serial.....\$ 59
 - Microsoft Mouse.....\$ 98
 - SummaMouse-Optical.....\$ 85
 - SummaSketch 12x12.....\$365
- Project Management
- Harvard Total Project Manager.....\$399

* Compatibility with PC/XT/AT Clones not guaranteed.
* Order Carefully-opened software not returnable!

PRINTERS, PLOTTERS & FAX

brother Dot matrix, daisy wheel, laser printers, fax machines. CALL
houston instrument PLOTTERS DIGITIZERS

- Panasonic
- 1080I \$169
 - 1091 Model 2 \$199
 - 1092 I \$319
 - 1524 \$579
 - 1592 132 Col. 190 CPS \$429

XEROX

Xerox 7007 9600 BPS, 18 second / page, + phone with 99 number auto dial, 10 pg feed, up to 7 day delayed send, 200x400 resolution..... \$1,349
7011, 7018, 7020, 7021, Faxmaster/PC CALL

LASER PRINTERS & SCANNERS

Brother HL-8 40 fonts 8PPM 2nd Gen. Canon Engine Emulates Epson, IBM, Diablo 1Mb RAM-Full Pg graphics HP LaserJet Plus compatible



\$ 2,895* CALL

AST TurboLaser/PS postscript, ricoh, 3 Mb, 35 fonts, 8ppm, AppleMac/PC..... CALL
H.P. LaserJet Series II..... CALL
Panasonic 4450 Laser dual tray, 11PPM ... \$1,695
HP ScanJet Scanner with Starter Kit \$1,895
HP Font Cartridges.....FROM\$119

DRIVES - HARD, FLOPPY & TAPE

EVEREX

Everex 60I - 60Mb internal tape with software. \$729
Everex 125Mb Internal Tape\$988

CDC 300Mb SCSI -for NetWare 2.11 & DCB CALL

Maptor XT-1140 140Mb\$1,695

MICROPOLIS 85Mb 28mSEC.....\$ 649

MiniScribe Miniscribe 3053 half height 22mSec 53Mb.....\$449
ScribeCard 30Mb.....\$339

Seagate

Seagate PC 20 Mb with WD Ctrl \$ 269
Seagate PC/XT 30Mb ST-238, ctrl, cable.....\$289
Seagate ST251-1 - 40Mb AT 28mSEC.....\$498

Floppy Drives

Fujitsu 360K \$75/1.2 Mb \$95/720K \$98/1.44 \$109
Mitsubishi 360K \$89/1.2 \$125/720K\$99 /1.44 \$119
Teac 360K \$ 89 /1.2 \$ 99 /720K \$88 /1.44 \$ 98

MODEMS & BOARDS

ANCHOR

1200 External \$ 98 / 1200 Internal \$ 69
2400 External\$135 / 2400 Internal \$115

EVEREX

Everex EverCom 2400 Int. 2400 (MNP)\$139
Everex EverCom 2400E Ext. 2400 (MNP).....\$189

MultiTech Multi-ModemsCALL

Robotics

US Robotics Courier HST up to 19,200 bps CALL
2400 Ext.....\$168 / 2400 PC\$148
1200E.....\$ 98 / 1200 PC\$ 68

AST Advantage-Prem-512K, S, P...\$308
Advantage PS/2 - 512K\$365
Hot Shot 286-10XT Accel. Bd. \$369
I/O MINI II-XT or AT\$ 75

RAMPAGE 286 - 512K\$395
RAMPAGE2 for XT 256K - Model 30.....\$279
RAMPAGE Plus 286-512K microchannel\$509
SIX PAK Plus 64K\$119
VGA\$259 / VGA 256K...\$359

XFORMER - AT replacement, for XT's 8 slot MB, 10 MHz "0", 512K, S,P,C, floppy and hard drive controller, EGA, CGA, HGC.....\$629

5251/11 Plus AST Guarantee.....\$598

Everex UltraGraphics & 19" Monitor. CALL
Floppy I/O S, P, G, C\$ 89

EGADix. 800x600EGA-P \$149/VGA \$259

int Above Board/286 -PCMB4020 512K. \$ 388

80387-20 Math Coprocessor.....\$ 549

TELEX 9103806778 SNSCORP For Orders

S-100 Div./696 Corp. ♦ 14151 N. 76th St. ♦ Scottsdale, AZ 85260

FAX 602-483-0920 ♦ Customer Service 602-991-7870

Prices advertised are for 110 Volt products. 220 Volt products are available at slightly higher prices.

Advertised prices are cash (U.S. Dollars), prepaid, Visa or M/C Only! Customers using American Express, calculate additional charges by dividing above prices by .95. Special order items require prepayment with other than credit card and they are not cancellable/returnable. All returns subject to a restocking fee or full credit towards a future purchase. All prices subject to change without notice. Credit card charged after shipment. Opened Software packages are not returnable! Contact our International Department for shipping, handling, and insurance charges.

A Multiprocessor System From Your IBM PC AT

North Star's new EL-286 package turns an IBM PC AT or compatible into a multiprocessor system that can support up to four users and run multiuser software designed for Novell NetWare, as well as standard DOS programs. The package consists of two workstation cards, Novell ELS NetWare operating software, and the necessary cables and connectors.

Each full-size card contains an 8-MHz 80286 microprocessor, 640K bytes of zero-wait-state memory, and EGA graphics. When you connect a display and a keyboard, you get the equivalent

of an AT. The host machine in which you install the cards becomes the file server, and it must have at least 1.5 megabytes of memory and a 20-megabyte hard disk drive; all communication between the host and the workstations takes place over the 16-bit AT bus, which gives you considerably faster performance than a normal local-area network, according to the company.

The cables run from the host to a connector box that sits on each user's desk. They contain monitor and keyboard sockets plus an RS-232C serial port for local communications, such as with a serial printer.

Price: £3000 for the EL-286 package for two additional users; £320 for two keyboards and monochrome displays; £1335 to add a third

user; £1495 for a third user with keyboard and monitor. **Contact:** North Star Computers Ltd., 39 Queensway, Hemel Hempstead, Hertfordshire HP2 5HE, U.K., (0442) 41266.

Inquiry 838.

QuickBASIC for the Mac and Microsoft Works 2.0

The Macintosh version of Microsoft's QuickBASIC compiler includes an improved environment with a full program editor, and it supports music and color graphics, giving you access to the Mac Toolbox routines. QuickBASIC combines an interpreter and a compiler so you can use the interactive inter-

preter environment for program development and debugging, and then you can compile a stand-alone application.

The compiler supports the 68020 microprocessor and the 68881 floating-point coprocessor. Debugging features include single-stepping and animated tracing and breakpoints for source-code-level debugging. On-line help is provided for BASIC keywords, library calls, and ROM routines.

QuickBASIC 1.0 requires a minimum of 1 megabyte of memory and either an 800K-byte floppy disk drive or a hard disk drive.

Price: £75 for QuickBASIC 1.0; free as an upgrade for Microsoft Mac BASIC users who registered after Aug. 1, 1988; £30 for other existing

continued

k a d o r's

Seal'n Type
The protective keyboard cover through which you can type freely and easily!

TRADE ENQUIRIES WELCOME

Wide range Ex-stock & available custom-made

KADOR
Unit 4
Pontcynon Ind. Est.
ABERCYON
MID GLAM.
CF45 4EP U.K.
Tel: 0443 740281
Fax: 0443 741559

- Accidents can happen!
- Protect against spills, dust, ash and grime; any of which could ruin your keyboard.
- Saves servicing costs.
- Stops erosion of key lettering.
- Made of clear, flexible p.v.c.
- Moulded to fit over each and every key.
- Typing is unimpaired.
- Easy fitting instructions.

Circle 445 on Reader Service Card

DISK CONVERSIONS

DISK/DISK • DISK/TAPE • TAPE/TAPE

We can transfer your data between over 1,000 different Micros, Minis and Mainframes, giving more than 1,000,000 permutations

Type
1/2" - QIC-11, QIC-24, (QIC-02)
1/2" - 800, 1600, 3200, 6250 BPI
ANSI, CPIO, DEC 'DOS', IBM Labelled / Unlabelled / ASCII / EBCDIC / Binary, ICL 6 bit, TAR, VAX Backup / Copy, VME
DEC - TK50, TS11, TU58; RLO2 removable disk pack

Floppy
8", 5 1/4", 3 1/2", 3"
Acorn, Amiga, Amstrad, Apple, Archimedes, Atari, CP/M, CP/M86, FLEX, IBM, Idris, ISIS, Macintosh, MDOS, MS-Dos, OS/9, PC-Dos, RT11, Torch, Unix, Victor-Sirius, Xenix and more

WP / Typesetter
Many formats, including Displaywriter, Olivetti, Wordplex, Linotype...

Disk to Page
Typesetting / Laser printing, full design and print production services

Overnight - Most formats returned by next day's post

Kernit Distribution Centre

Ring or write for a full format list
Prices from £10 + VAT per disk

Usual terms C.W.O.  

A.L. DOWNLOADING SERVICES
VOYSEY HOUSE
BARLEY MOW PASSAGE
LONDON W4 4PT
Fax: 01-994 4959
Tel: 01-994 5471



Circle 424 on Reader Service Card

THE SECRET OF GERMAN DESIGN

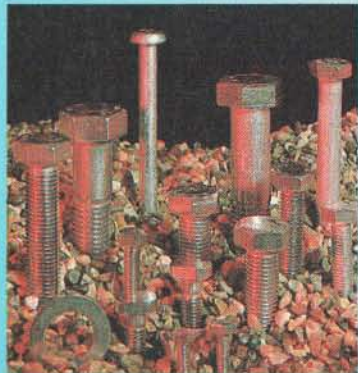
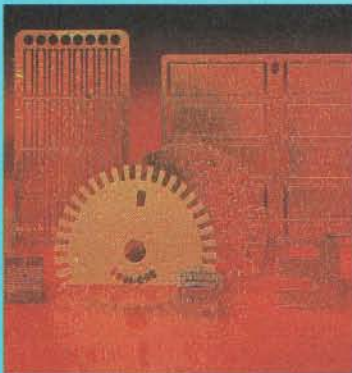

Quality, integrity and reliability are all characteristics of German design. To help build these qualities into their products German designers have a secret advantage: PC-DRAFT.

The best-selling German CAD-system, PC-DRAFT now has over 5,000 installations worldwide and is ideal for all mechanical engineering, electrical engineering, technical documentation and architectural applications.

Easy to use, powerful facilities enable you to operate the system quickly and efficiently. This means you'll get the most out of the many features available. These include a unique perspective design module which offers easy production of multiple viewpoint perspectives for exploded drawings and technical illustration.

Now the secret's out, call Ernest McCutcheon on (0344) 863150 for the full story.

rhv Software Systems UK
Farley Hall
London Road
Binfield
Bracknell
Berks RG15 5EU
Telephone: (0344) 863150

rhv – quality from strength

users of Mac BASIC.

Contact: Microsoft Ltd., Excel House, 49 DeMontfort Rd., Reading, Berkshire RG1 8LP, U.K., (0734) 500741. Inquiry 831.

A Music Guide and Information through Your Computer

FM Tokyo and Shobi College jointly offer the FM P-NET (Fine Music Personal Computer Network) communications service. The FM Tokyo program schedule and music data is provided, along with electronic mail, bulletin board system, and conferencing services.

About 3000 music data entries include classic, rock, popular, movie soundtrack, jazz,

and Japanese country and love song sectors. You can download and play the music data with a special software and musical instrument digital interface board option. The software runs on NEC PC-9801, Fujitsu FM R-50/50S, Panacom M500, and Epson PC-286V/U systems.

Membership is free during a trial period, and there is no monthly fee. There are about 90 access points throughout Japan, and members also receive NIFTY-Serve service.

Price: 20,000 yen for the software; 3000 yen for membership.

Contact: FM Tokyo, FM Center, 1-7 Kojimachi, Chiyoda-ku, Tokyo 102, Japan, Shobi Gakuen, 4-15-9 Hongo, Bunkyo-ku, Tokyo 113, Japan, 03-818-4154. Inquiry 841.

A Faster Solution for the Traveling Salesman

Connections: The Traveling Salesman is a tutorial on neural networks. It is an examination of the Hopfield-Tank approach to the traveling salesman problem (TSP), which in turn is an optimization problem. The program is 16-bit-integer-based and solves a 10-city problem in 6.1 seconds on a 4.77-MHz 8088 microprocessor, according to the company.

DAIR Computer Systems used a nearest-neighbor heuristic algorithm and chunking/clustering, which are the methods used by biological neural nets. The program also uses the concept that the

rabbit olfactory cortex sculpts up (rather than down) the energy surface of a smell pattern. Connections: The Traveling Salesman starts with weights set at 0, which is the opposite of Hopfield-Tank. According to the company, it also improved the speed by creating a lookup table of the time-consuming hyperbolic tangent activation function.

Connections: The Traveling Salesman runs under DOS 2.0 or higher on the IBM PC, XT, AT, and compatibles with 256K bytes of memory and one floppy disk drive.

Price: 9800 yen.

Contact: Toyo Engineering Corp., 6th Floor, Shibuki Building, 4-6-11 Kudan Minami, Chiyoda-ku, Tokyo 102, Japan, (03) 222-0541. Inquiry 847.

continued

FORECASTING is EASY

PRO*CAST is the easiest to use forecasting program for the IBM-PC.

AUTOMATIC. Artificial intelligence gives you EXPERT results - even if you're a novice. Just enter your past history for sales, inventories, revenues, etc. and hit one key. You'll have a forecast in less than 30 seconds on most computers.

POWERFUL. Take full manual control, and choose from over a dozen methods - from linear trend to Box Jenkins. You can even draw your forecast on the screen. Full screen editor. Reads WKS/ASCII. GREAT GRAPHICS!

IBM-PC or 100% compatible with 512K & graphics. US \$295 + s/h. 99% functional demo \$10 + s/h. VISA/MC. WE SHIP AIR MAIL OR COURIER. CALL OR WRITE FOR QUOTE.

by FLEMING SOFTWARE
distributed outside the U.S. by

OVERSEAS TECHNOLOGY, INC.
PO Box 5195, Arlington, VA 22205 USA
703-538-4261

FAX: 703-525-8115
TELEX: 650 155 7424 MCI UW

DEALER INQUIRIES WELCOME

Circle 436 on Reader Service Card

IEEE 488

Technology that hits the mark

- For IBM-PC/XT/AT/386, IBM-RT 6150, IBM-PS/2, PHILIPS :YES and all compatibles
- For MS-/PC-DOS, OS/2 and UNIX
- Extremely fast and easy to use software
- All HP-IB commands (ONSRC etc.) are implemented
- Compatible to ASYST, AutoCad, National Instruments, CEC etc.
- Real time error checking and bus analysing
- Supported Basic (compiled), Turbo-Basic, (Turbo-) Pascal, Modula-2, Fortran, C, Assembler etc.
- Available in English, French and German

Dealer + OEM Welcome



Ines GmbH
Neuenhofer Allee 45
5000 Köln 41
West-Germany
Phone: +49-221-43 88 59
Teletex: +26 27-221-42 37 gizkln
FAX: +49-221-49 18 71

Circle 443 on Reader Service Card

FOUR TIFIED LAN



FOUR PCs on ONE card

Putting together a PC Network has never been easier.

QuickLink IV has done to PC networking what the microwave oven has done for modern cooking . . . Both have proven to be a more efficient, convenient way to get your work done FAST . . .

By adding QuickLink IV multi-user LAN boards to your Compaq 386, IBM PC/AT or compatible systems, you can create an instant, low cost PC network with tremendous expansion capabilities.

Thousands of Novell ELS and Netware 286 compatible software packages run on QuickLink IV boards.

QuickLink IV contains four individual PCs (each with 768K RAM) on one board that plugs directly into your PC/AT's internal bus. Your network runs at full bus speed, allowing you to configure a faster LAN than traditional cable-based architectures . . . hassle-free from hubs, network cards and complicated wiring schemes.

By using small footprint, noiseless PC terminals, your PC/AT becomes a modular foundation for a network of users. The AT bus will typically support four QuickLink boards (16 users), or more with Cubix's optional Expansion Chassis.

QuickLink IV can also be used to link remote PCs into your network. Cubix asynchronous software expands the boundaries of your LAN by using one or more of the QuickLink IV's processors as dedicated asynchronous servers. You can run your network application programs and initiate bi-directional file transfers from any remote location.

Move FOURward.

Call 1-800-648-2130 or (702) 883-7611 to order.

Compaq 386 is a trademark of Compaq, Inc.
IBM AT is a trademark of International Business Machines Corporation.
Novell NetWare is a trademark of Novell, Inc.

Made in the U.S.A.

 **CUBIX**
CORPORATION

Corporate Offices • 2800 Lockheed Way, Carson City, Nevada 89706 • Tel (702) 883-7611 • Fax (702) 882-2407

Circle 431 on Reader Service Card

NOVEMBER 1988 • BYTE 88IS-39



FRIL

THE NEW ARTIFICIAL INTELLIGENCE PROGRAMMING LANGUAGE FOR MODELLING UNCERTAINTY

FRIL is the first AI programming language to be based on Support Logic, a formal calculus for uncertainty reasoning. The unique features of **FRIL** put it ahead of conventional Prologs for complex applications involving uncertainty.

Evidential Reasoning with Support Pairs
Fuzzy Sets and Semantic Unification
Open Worlds and True Logic Negation
Prolog as a subset of **FRIL**

Written in C, **FRIL** is highly portable and available across a wide range of computers.

EQUIPU  AIR LTD

184 Hotwell Road Bristol BS8 4SG. Tel: (0272) 213427/277551

_____ ✂
If you are interested in knowing about **FRIL** please complete and return this coupon to: Equipu AIR Ltd., 184 Hotwell Road, Clifton, Bristol BS8 4SG. Or ring us on (0272) 213427/277551.

NAME: _____ TITLE: _____

COMPANY: _____ TELEPHONE: _____

ADDRESS: _____

POSTCODE: _____

BM 

DENON NOW!

Floppy Disk to Large-Capacity Optical Disk.



(Glass disks prepared for CD mastering)



(Erasable disks)



(Large capacity memory media)

DENON delivers the future. It shines in advanced floppy disk and new large-capacity optical disc memories. Over 30 years of magnetic media experience open up exciting personal computer possibilities. DENON—a growing high-tech product family.

DENON has come to be synonymous with high quality audio and video, thanks to the corporate philosophy of integrating hardware and software development, and continuously upgrading and introducing new technologies. DENON expends considerable time and resources on R&D because, as a leader of the industry, there is no place else to turn for new ideas. The Company must constantly open up new areas if the pace of progress is to be maintained—and it is.

DENON

NIPPON COLUMBIA CO., LTD.
14-14, Akasaka 4-chome, Minato-ku, Tokyo 107, Japan
TEL (03) 584-8111 TELEX JAPANOLA J 22591 FAX (03) 586-1859

Authorized DENON Floppy Disk Distributors:

LOADPLAN COMPUTER	TEL 01-200-7733 (UK)
JOD ELECTRONIQUE	TEL (1) 47329260 (France)
TELEDYNAMICS	TEL (069) 30 09 06-0 (West Germany)
INTERMEDIA	TEL (02) 2829105 (Italy)
ELECTROQUIPO	TEL 1-370317 (Portugal)
INGENIERIA	TEL 204 20 99 (Spain)
CASSETTE SOUND	TEL (031) 512 60 (Greece)
UNIVERSAL ELECTRONICS APL	TEL 3-8981541 (Saudi Arabia)

AUDIONORD	TEL 12 88 11 (Denmark)
STOET ELECTRONICS	TEL 070-475565 (Holland)
ATARI (SCHWEIZ)	TEL 056 21 1422 (Switzerland)
OY NEPCON	TEL 90 566 4844 (Finland)
ALBERTA ELECTRONIC	TEL 3-347411-5 (Hong Kong)
PAN SYSTEMS	TEL 7475221 (Singapore)
UNIVERSAL ELECTRONICS CO.	TEL 246 628516 (Kuwait)
GUVENTAG	TEL (4) 229 09 20 (Turkey)

Connect Your Workstation to ICLC-03 Networks

You can connect workstations attached to a local-area network (LAN) supporting the NETBIOS interface standard to ICLC-03 networks using the LAN-C03 gateway from The Software Forge.

The software architecture consists of two distinct modules, a gateway and a workstation, which communicate across the LAN using NETBIOS commands. The gateway package provides its own automatic task-switching capability between the workstation application interface and the ICLC-03 communications software.

The communications hardware, which is resident only in the gateway processor, consists of a half-size IBM PC board that provides an interface for leased-line, direct, and dial-up connections. You can configure the board to fit available I/O addresses, and it can use any interrupt request line. You can use communications data transfer rates up to 48 kilobits per second.

The gateway implementation can operate in foreground or background mode and allows up to 20 concurrent workstation sessions per gateway implementation. Multiple gateways support additional concurrent sessions as well as higher throughput capability.

The LAN-C03 software runs under PC-DOS 3.1 or higher, and the LAN-C03

gateway module must be resident with at least one workstation option. The gateway implementation requires 256K bytes, and the workstation software requires 180K bytes.

Price: £650 for 10 sessions; £150 for the communications card.

Contact: The Software Forge Ltd., 173 Basingstoke Rd., Reading RG2 0HF, U.K., (0734) 312477.

Inquiry 876.

and then integrate it into popular spreadsheets or databases available for the IBM PC, XT, AT, PS/2s, and compatibles.

You can take data from files located in a variety of environments, such as mini-computers and mainframes using IBM, Bull, DEC, or Hewlett-Packard formats; telex; and videotex systems, such as QUBE or Prestel; and then create an intermediate file to receive the incoming data. Databridge uses this file to supply the data for direct conversion into other formats or for the updating of spreadsheets and databases you have produced using Lotus 1-2-3, Symphony, Multiplan, Framework, Open Access, dBASE, and other products that use the Lotus

continued

Mainframe Data for Spreadsheets or Databases

Databridge from Comedia lets you retrieve data you need from source code files located on a mainframe

The Best Thing Next to your Laser Printer

LASERMATE is the first peripheral management unit specifically designed to help you make the most of your investment in laser printers, high-speed modems, and other expensive peripherals.

With LASERMATE, every PC user in your office can choose where to send output without cable-shuffling, knob-turning or head-scratching.

Stylish in appearance, easy to connect and use, LASERMATE goes beyond the switch-box and buffer* to provide a complete solution to your peripheral sharing problems.

Mutek Ltd, Frome Rd, Bradford on Avon, Wilts BA15 1LE, England.
(+44) 2216 6502 /Fax:(+44) 2216 5083

Circle 448 on Reader Service Card

IBM-PC BUS Input/Output Cards

DIP-24	Opto-isolated digital input
DOP-24	Opto-isolated Darlington output
PIO-48	TTL level digital input/output
DPC-10	Pulse counter/timer/generator
DCM-16	8 Inputs, 8 Outputs, CTC
AIP-24	12 Bit ADC input
AOP-8	12 Bit DAC output
AIS-16	12 Bit isolated ADC input
TIP-8	Thermocouple input
SIO-2	RS232/422/485/20mA I/O
ST-24	Screw terminal adaptors
BXT	Backplane extenders
BP-5/11	5/11 Slot backplanes

BLUE CHIP TECHNOLOGY

Blue Chip Technology Limited, Main Avenue, Hewarden Industrial Park, Manor Lane, Deeside CH5 3PP. Telephone: (0244) 520222.

Circle 426 on Reader Service Card

The Acer LP-76. The Spectrum of Value.



Building a Better Standard for Laser Printing.

Acer has transformed its corporate values of quality, innovation, and customer satisfaction into its new laser printer, the Acer LP-76, an outstanding desktop solution for the personal computer environment.

The LP-76 makes laser printing easy. With its 16 character LCD control panel, you can access three menus that make printing operation simple and quick.

And the Acer LP-76 adheres to and surpasses the industry standard today, offering true Hewlett-Packard LaserJet Series II emulation. Designed with state-of-the-art ASIC chips, the LP-76 offers impressive performance, with incredibly fast downloading speed in printing complex text and graphics combinations, ensuring you get fast, professional documents.

Standard with 512KB memory, and easily expandable to 4.5MB, the Acer LP-76 can print in many languages, a full spectrum of fonts, and characters up to 655 points

in size. All this means incredible versatility for you, designed to satisfy your laser printing needs.

All these features plus Acer's commitment to quality, innovation and customer satisfaction, combine to create a laser printer of unparalleled value. And Acer backs up this value with over 12 years of experience and a distribution network covering over 70 countries worldwide.

The Acer LP-76.
Based on the right values.

LP-76 Features:

- HP Laser Jet Series II Emulation
- 512KB RAM on Controller Board, Expandable to 4.5MB RAM for Page Composition
- 16 Character User-Friendly LCD Display

Handy Scanner Features:

- High Resolution: 400/300/200 DPI
- Powerful Image-Editing S/W
- Compact Size, Easy to Operate

Hewlett-Packard and LaserJet Series II are registered trademarks of Hewlett-Packard Corp.

Circle 423 on Reader Service Card

Acer
The Word for Value



1-2-3 format.

Menus take you through each step of every operation, providing you with immediate access to the program's retrieval and transfer functions. The program's capabilities include consolidation of numeric and alphanumeric data from multiple sources; data retrieval using standard comparison operators; user-defined mapping of data of layouts using vertical, horizontal, and cell-skipping functions; and automatic summation of source data on request. Databridge also works in batch mode, freeing you for other jobs while it gathers and translates information you have requested.

Databridge runs under DOS 2.1 or higher on the IBM PC, XT, AT, PS/2s, and compatibles with at least 256K

bytes to 640K bytes of memory, two floppy disk drives, and a hard disk drive.

Price: \$99.95 U.S.

Contact: Comedia, Cap Alpha Montpellier, Clapiers, 34821 Teyran Cedex, France, 33-01-67-59-30-75.
Inquiry 863.

A Hand-Held Data Analyzer

The Databox Mini Data Analyzer (MDA) is a hand-held diagnostic tool to help you solve many of the problems experienced when you are installing or operating data communications systems. It can capture data on transmit and receive directions, perform bit-error-rate testing, and monitor modem

control signals, all in a battery-operated package weighing less than 1 kilogram.

The MDA can capture data on separate transmit and receive buffers, each with 28K bytes capacity. You can specify whether the data is presented to you in ASCII or hexadecimal form on the 40-character transmit and receive liquid crystal displays. To isolate fault sequences in the data, you can set the MDA to start and stop data capture on preset sequences.

The MDA can also operate as a data test set and terminal exerciser, and it has serial printer output for permanent data capture. The configuration is menu-driven, from front-panel switches, and the configuration details and the contents of the buffers are protected by a battery backup.

The MDA shows modem control (V.24/RS-232C) line states, and stores these with the data for later diagnosis.

Price: 975 Swiss francs.

Contact: Databox S.A., 48 Route des Acacias, CH-1227 Geneva, Switzerland, (41) 22-42-21-30.
Inquiry 882.

Fix

There is an error in the address of BON/CSS-Flensburg in What's New International, page 88IS-10, August BYTE. Although the street address is correct, the company is located in West Germany, rather than Sweden as stated. We apologize for any inconvenience this may have caused.



MicroCache

TURBOCHARGE YOUR SYSTEM

- Europe's best selling disk caching & printer buffer software.
- No need to change your system, no extra hardware
- Saves time. Unbeatable speeds, performance, technology.
- FREE Demo Disk, IBM 5 1/4".
- NEW Prices! From £69

Microcosm Research
Telephone: 01-226 9092
Telephone: +44 (0)1-226 9092

Circle 447 on Reader Service Card

Advertise your Computer Products through BYTE BITS

2" x 3" ad size
(5.1 cm x 7.6 cm ad size)

in BYTE's International Advertising Section

For more information
Call Karen Lennie
at 01-493 1451

McGraw-Hill Publications
34 Dover St.
London W1X 3RA

Circle 427 on Reader Service Card

*A Brilliant
Combination*

*Let's Relieve You of Your
Headache With.....*



- Microprocessor 80386-25
- Supports 80387 Co-processor
- Fully support all network software



- Microprocessor 80286-16
- 512K, 640K, 1, 2 or 4MB
- Memory on board, expandable to 16MB
- Interleaved page mode allows superfast performance



- Microprocessor 80386-20
- 1, 2, 4 or 8MB memory on board expandable to 16MB
- Interleaved page mode allows superfast performance

SMT

By the end of 1988, ABC will be introducing a new technology in PC board manufacturing called "SURFACE MOUNT TECHNOLOGY" which will further augment our current production capacity to cope with present and future expansion as we progress towards the year 2000.

This new technology gives a better quality on our products. The fully automated assembly line eliminates any human error during the manufacturing process. Reduced size on components will further reduced the size of the finished products.



See us at

COMDEX/Fall '88

November 14-18, Riviera Hotel, Las Vegas, Nevada, U.S.A.

ABC

ABC Computer Co. Ltd.
Manufacturer & Exporter

Basement 66, Golden Shopping Centre, 148 Fuk Wah Street, Shamshuipo, Kowloon, Hong Kong.
Tel: 3-7290238 (12 lines) Fax: 3-879279 Telex: 52178 ABCTC HX Cable: ABCTDGOHK

EUROPEAN VIDEOTEX

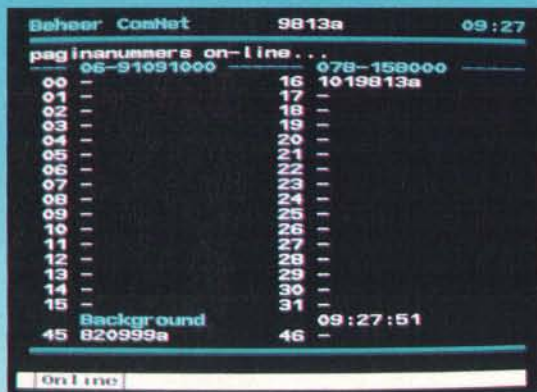
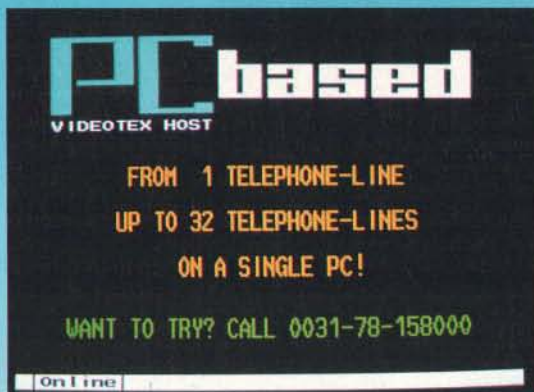

MT-TEL a private videotex databank system

Up to 32 users simultaneously

MT-TEL is a high performance, low-priced private Videotex system. Due to its self-contained multi-tasking, multi-user operating system, the MT-TEL Videotex database system has a performance only found in mini's or mainframes. With commercially available I/O cards and modems, a standard PC AT can serve up to 32 users simultaneously, using your MS-DOS 3.2!

Quickly up and running

The MT-TEL software comes with a comprehensive manual and is easy to operate. Due to a starter database, which contains a number of sample videotex pages and all available editors (for pages, users, Information Providers, etc.), a new setup is easy and does not take much time.

Fully-blown software

The MT-TEL package contains everything a grown-up Videotex database system should have: Closed User Groups, Information Providers, Data-collection pages, Electronic Mail (Individual-, Group- and Registered E-Mail, Store-Mail, etc), Dynamic pages, Log-files, Password-Protection (3 levels), Sub-Databases and a number of additions to the Prestel Videotex normalisations.

X25 Gateway

You don't want to use the Public Switched Network? MT-TEL can be interfaced to the X25 datanetwork as well through the 2.1 and 2.2 type Gateway protocol. Almost any European country now has the V.A.P. (Videotex Acces Point) structure connected to its X25 data network. The MT-TEL system connects to that network by an X25 Gateway interface. It enables you to be reached all over the country or all over Europe.

A heavily tested software package

The MT-TEL private Videotex databank software has been tested thoroughly in field-installations during several years. In use in Holland by a.o. the largest private, public Videotex databank ComNet with over

10.000 users and 120 telephone lines, and also by Wehkamp, the major mailorder warehouse in the Netherlands to enable tele-shopping or Merck, Sharp & Dohme pharmaceutical industry, using an IBM System 38 front-end connection. In Belgium by Elma, the countries largest wholesaler of electrical goods. In Italy at the Borsa, the Milanese Stock Exchange. And added to that we can mention a number of smaller systems, varying from 2 telephone-lines to over a 100. Proving that the MT-TEL private Videotex system is unbeatable in performance!

Try it right now? That's possible!

If you have a Prestel Videotex terminal (or program on your PC), try-out the MT-TEL system right now! Call the Dutch ComNet system, a large public databank and see for yourself how the MT-TEL software performs. Sorry, you can only access a few of the 40.000 pages without being a member of the system. Of course you can subscribe to it (without any charge). But if you use the guest number, which is displayed on the welcome page you can try the system yourself.

There are three phone-numbers (in Holland) which you can use and which will connect you to one of the front-ends each having 32 telephone lines. Dial: (Holland's country code is 31) 78 158000 or 78 156100 or 78 159900. (Use standard Prestel settings 1200/75 baud.)

Easily expandable

MT-TEL was actually developed to serve up to 32 users simultaneously. It took a number of man-years to develop the software and test it in a real environment. So we decided that the price should be over \$20,000.-- for the package, since it performs like Videotex software costing 5 to 10 times that amount on mini's and mainframes. But we are interested in selling a high number of packages and also to position the software in the low-end market for the smaller system. So now, we sell this 20,000 dollar software with a protection device to setup smaller systems for a low price.

Starting with a 2 telephone line system (plus the keyboard and the monitor of the system, so actually a 3-user system) for only \$1095.--.

A demo package is available

We have the same fully-blown Videotex Host software for you in a demo package. This demo-package has the same complete databank store- and retrieval structure as the real package (actually, it is the real package), but we restricted the software to use only the keyboard and the monitor of the computer itself to access the system. You can use the demo package (and the official manual) to test it, even to setup a complete database and, if you are fully satisfied, buy the original package, allowing you to handle telecommunications completely. The demo and the original package are fully file- and function compatible. We'll even pay you back the cost of the demo package when you buy the original software!

The demo package will only cost you \$245.-- (including shipping in Europe). And remember, we'll send you the \$20,000 software for that price!

How to order or to obtain information

You can order a demo or obtain a brochure by phone, by fax, by telex and (of course) by Videotex! Use your Eurocard, Mastercard, Visa or American Expresscard to have your order shipped today.

Micro Technology b.v.
Weteringsingel 6
3353 GZ PAPENDRECHT
NETHERLANDS
Phone xx31-78-410977
Fax xx31-78-150849
Videotex Orderline:
xx31-78-158000
Telex 62425 mtsft nl

We are looking for dealers and distributors

BYTE

Limited Editions



#G Programmable Hardware \$55

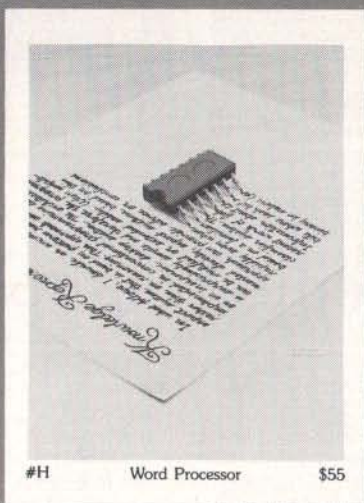

#H Word Processor \$55

You've seen them on the pages of *Byte* — now enjoy these delightful images as stunning limited edition prints! Each exquisite, 16" x 20" reproduction is part of an edition strictly limited to only 1000 prints. The museum-quality paper is an acid-free, 100% cotton fiber stock (highly resistant to yellowing or cracking) which will preserve image color and brightness for generations.

The artist, Robert Tinney, personally inspects, signs and numbers each individual print. Accompanying the print is a Certificate of Authenticity (also signed and numbered by Tinney) which verifies the number of the edition and the destruction of the press plates.

The price of each print depends on the number of unsold prints in the edition, and is shown beneath the photos at left. If your order exceeds \$100, deduct 15%. All prints are shipped flat via UPS Blue Label, and carry an unconditional 30-day guarantee.

To order, clip the coupon below. VISA, MasterCard or AmEx orders may call 1-318-826-3003.

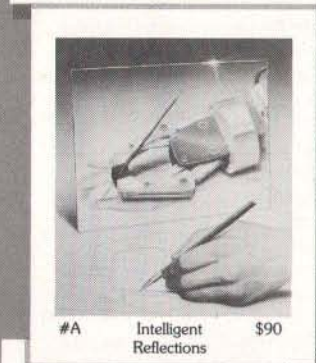

#A Intelligent Reflections \$90

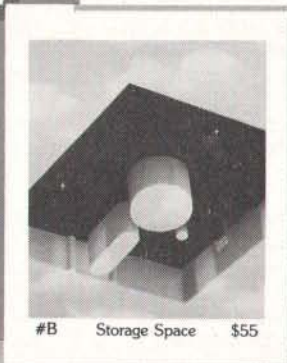

#B Storage Space \$55



#C Technological Breakthrough \$60



#D Number Crunching \$55

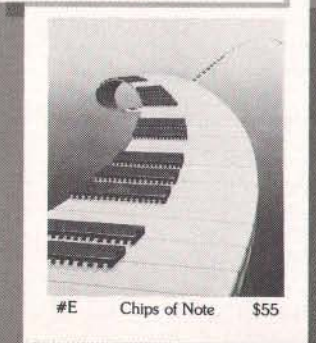

#E Chips of Note \$55

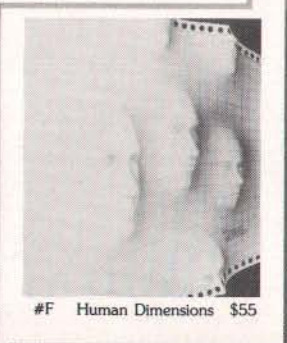

#F Human Dimensions \$55

YES! Send me the following Byte Limited Editions.

QTY.	#	TITLE	AMOUNT
			\$
			\$
			\$
			\$
			\$
			\$
			\$
		If your order exceeds \$100, deduct 15%.	\$
		\$4 postage & handling (\$25 overseas).	\$
		TOTAL	\$

- Send a color brochure showing your other prints.
 I have enclosed U.S. check or money order.
 C.O.D. (via UPS—stateside orders only)
 VISA MasterCard American Express

Card #: _____

Expires: _____ Signature: _____

SHIP MY PRINT(S) TO:

Name: _____

(Business): _____

Address: _____

City: _____

State: _____ Zip: _____

Country: _____

Mail this coupon to:
ROBERT TINNEY GRAPHICS
 P.O. Box 778 • Washington, LA 70589

For VISA, MasterCard or American Express orders,
 or for more information
CALL 1-318-826-3003



RPTI-NET 3000 Ethernet

RPTI-NET 3000 is a high-performance Ethernet LAN for the IBM PC/XT/AT/386, PS/2 and compatibles running under PC-DOS/MS-DOS 3.10 or above.



Features:

- 10 Mega Bits/Sec, CSMA/CD
- IEEE 802.3 Standard
- 1,000 Meters with Repeater
- 30 Nodes Per Segment
- Networking Software Versatility:
 - RPTI NOS (File Server)
 - Novell NetWare (NE-1000 Compatible)
 - IBM PC LAN Program
- PC/VAX Connectivity Supported

Build Up Networking And Telecommunications Power

Trans-Modem

The Trans-Modem is a fully HAYES-compatible compact-sized modem, designed for use with IBM PC/XT/AT/386, PS/2 and compatible series of computers and terminals. It conforms to the Bell 103/212A and CCITT V.21/V.22/V.22bis standards and can be instructed via the HAYES AT command set to automatically dial or answer calls.

Features:

- 100% HAYES Compatible
- Bell 103/212A and CCITT V.21/V.22/V.22bis
- Auto Speed Selection (300/1200/2400)
- Auto Dial and Auto Answer
- Save Configuration Profile
- Compact-Sized
- Internal Card Available



R.P.T. INTERGROUPS INTERNATIONAL LTD.

2nd Fl., No. 280, Chung Hsiao E. Rd., Sec. 4, Taipei, Taiwan, R.O.C.

• Tel: 886-2-7713366, 7411654 • Telex: 12219 RPTI • Fax: 886-2-7412946

SINCE 1975

BYTE & Europe



This winning combination reflects a decade of unparalleled circulation growth and reader acceptance resulting in an ideal marketing environment for European advertisers.

■ BYTE's paid circulation outside North America has grown from 7,300 in 1977 to over 89,000 in 1987. And just as the international microcomputer marketplace has doubled its growth in the last 4 years, so has BYTE's paid circulation. More importantly, 69% of these international subscribers are located in Europe, where each copy of BYTE is read and passed along to 3 additional readers, achieving a total European readership of 248,000.

■ BYTE attributes its international growth to the continued excellence of its editorial content, as well as to the unique opportunity it provides for advertisers wishing to reach non-U.S. countries. This unique opportunity is BYTE's *International Section*, a combination of monthly editorial pages and advertisements appearing only in copies distributed outside of North America. The Section contains customized editorial for BYTE's non-U.S. readers that focuses on the latest international products available.

■ BYTE's International Section allows both U.S. and non-U.S. manufacturers to reach BYTE's exclusive international audience at significantly-reduced advertising rates resulting in a low cost per thousand. With BYTE's current international circulation at 89,800, the one-time black-and-white rate of \$3,380 means that advertisers can reach these BYTE readers at the low cost per thousand of \$37.63, or, less than four pennies per contact.

For further information, contact your local BYTE representative listed opposite the *Alphabetical Index to Advertisers* located in the back of this issue.

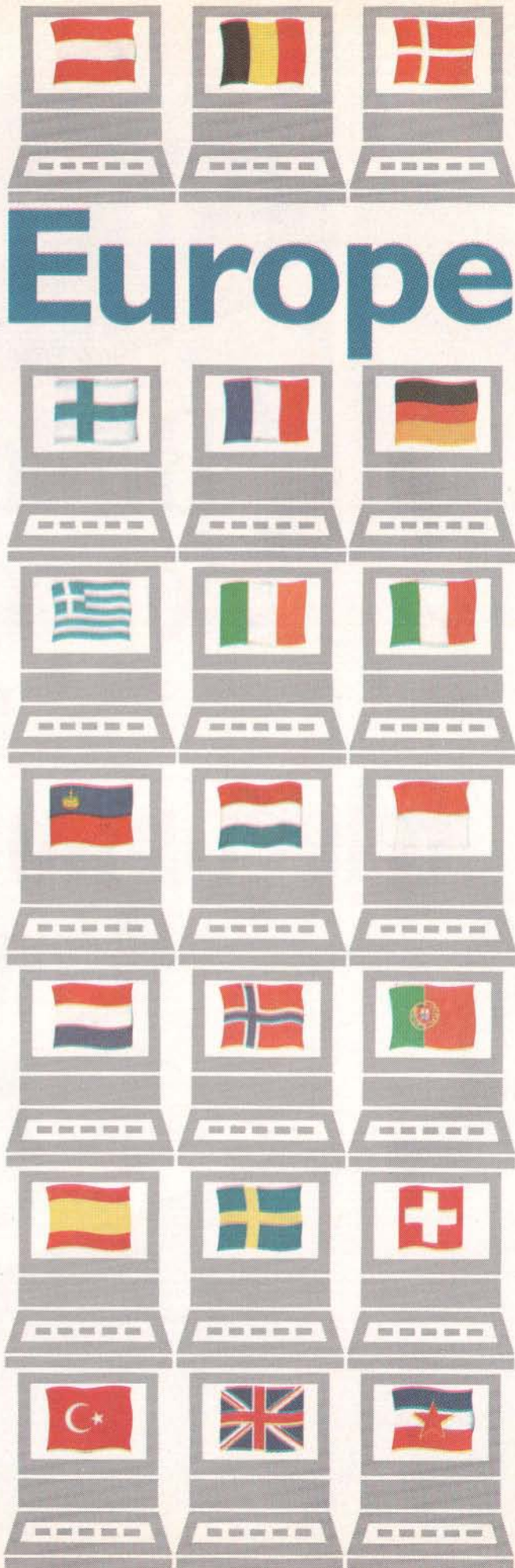



BIX IS GLOBAL



BIX is BYTE's Information Exchange, a worldwide computer conferencing system devoted to the exchange of microcomputer information.

When you use BIX, you leap borders of geography and time to exchange information, opinions and ideas with a "living database" of the world's most knowledgeable microcomputer users.

BIX covers the world.

Our *Microbytes* news service, backed by BYTE and McGraw-Hill, provides

worldwide daily news coverage of major events in the microcomputer industry plus listings of thousands of new products from vendors around the globe. Scores of companies now use BIX to provide technical support for their hardware and software products worldwide.

BIX saves you time.

BIX resources help you get the micro-related information you need right away, regardless of your location. BIX electronic mail lets you send private messages to

other BIX users worldwide. For more information on how to join and use BIX from your country, read the BIX message in this issue (see Advertiser Index for page number), or contact us today.

BIX

Circle 425 on Reader Service Card

BYTE INFORMATION EXCHANGE

One Phoenix Mill Lane
Peterborough, NH 03458 USA
(603) 924-7681 (Our overseas
helpline number)
8:30 AM-11:00 PM
Eastern Time
(-5 GMT) Weekdays



Gold. Standard.

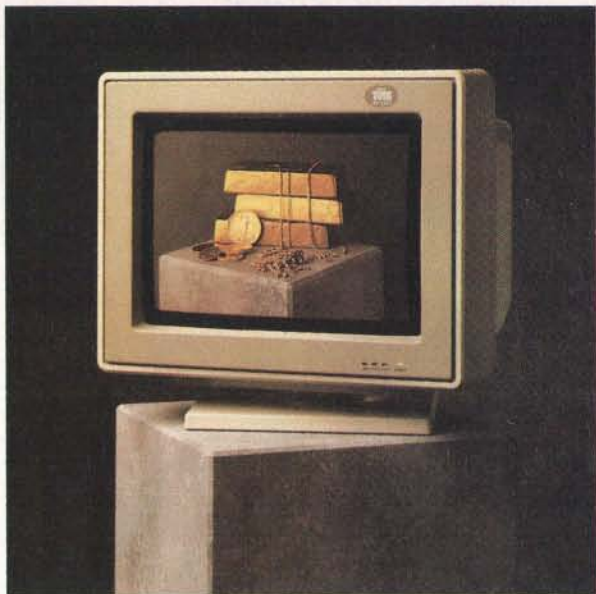

See what TVM monitors do for EGA and CGA.

Get outstanding display of the popular EGA and CGA text and graphics standards, with RGB monitors from TVM. Premium quality monitors that offer TVM reliability, TVM support and TVM value.

EGA has never looked sharper.

The MD-700 Multi-Display Enhanced EGA color monitor for IBM® PC™, XT™, AT™ and compatibles provides unmatched EGA color and resolution. A non-glare screen and the ability to select green, amber, white on blue, or full color text make the MD-700 ideal for everything from 1-2-3* to the most complex graphics applications.

CGA has never looked better.

Use any of the thousands of CGA programs with your choice of two TVM monitors. The MD-300 Multi-Display CGA color monitor runs on IBM PCs and most other popular personal computers. It allows users to select green, amber, white on blue, or full color text. And the MD-600 Multi-Vision CGA color monitor can also be connected to our unique Signal Link™* to see output from a video disk or VCR. Even to watch television.

You can depend on monitors from the professionals.

TVM makes a broad line of multi-sync®, VGA, EGA and CGA monitors, built and tested to exacting specifications.

Just like the millions of premium quality monitors we've built for customers in more than 60 countries. And since we carry the approvals of the world's leading safety and

communications standards agencies you can count on outstanding performance and reliability.

So contact TVM today. See for yourself how TVM monitors bring you outstanding display of the popular EGA and CGA standards.

*Formerly called TV-Mouse.



Key Features	MD-700	MD-600	MD-300
Modes	EGA/CGA	CGA	CGA
Resolution	640 x 350	640 x 200	640 x 200
Screen Size	14 inches	14 inches	14 inches
Option		Signal Link	
Adapters	IBM EGA Adapter, Prisma® EGAMAX, or equivalent	IBM CGA Adapter or equivalent	



TAIWAN VIDEO & MONITOR CORP. P.O. Box 3338, Taipei, Taiwan, R.O.C. • Telephone: 886-2-776-5318 • Fax: 886-2-721-4798 • Telex: 28190 TVMTWN
 Distributors and telephone numbers: AUSTRALIA Keller Automation 03-5801355 • CANADA TVM Video & Monitor Canada Inc. (604) 873-8111 Fax: (604) 873-3770 and Canera Technologies Inc. (416) 890-2525 • HONG KONG Macro Business Appliances Co., Ltd. 852-5-299601-9 • INDONESIA P.T.H.L. Enterprise 62-21-672697 • KUWAIT Zaid Al-Kazemi Sons Trading Co. 965-2437200/2411544 • NEW ZEALAND Melco Sales (N.Z.) Ltd. 64-4-697-350 • NORWAY Codeco AS 47-41-22113 • PHILIPPINES Complex International 63-2-213020/218991 • SAUDI ARABIA Ebrahim Bin Jassim Al-Jassim 966-3-8332109 • SINGAPORE Advanced Computer System Pte., Ltd. 65-2967211/2932937 and Goh Electronics (S) Pte., Ltd. 65-7329898 • SWITZERLAND Panatron AG Zurich 41-1-8103210 • UNITED STATES Text & Graphic Video Monitor Corp. (714) 9854788 Fax: (714) 985-8377
 West Germany Maxdata Computer GmbH Tel: 02043-46041

TVM and the TVM logo are registered trademarks of TVM Corp. IBM is a registered trademark and PC and PS/2 are trademarks of IBM Corp. PageMaker is a registered trademark of Aldus Corporation. AutoCAD is a registered trademark of Autodesk, Inc. Hercules is a registered trademark of Hercules Computer Technology, Inc. 1-2-3 is a registered trademark of Lotus Development Corp. Prisma is a registered trademark of Prisma Graphics. MultiSync is a registered trademark of NEC Corporation. **The Professional Monitor Company**

SHORT TAKES

BYTE editors offer hands-on views of new products

NEC Ultralite

NEC ProSpeed 386

The Norton Commander

Deskpro 386/20E

Personal Measure



NEC's Incredible Shrinking Computer

I just knew that the computer industry's quest for size reduction had to hit some limit. A display can get only so small before the characters become unreadable. Likewise, a keyboard can shrink only so far before it becomes unusable. Thus, NEC concentrated on collapsing the only remaining dimension: The NEC Ultralite is about as thin a computer as I've seen. With its cover closed, the Ultralite measures 8½ by 11¾ by 1½ inches. And at 4.4 pounds with batteries, it's one of the lightest.

The Ultralite (in above photo at right) comes standard with 640K bytes of RAM, a 1- or 2-megabyte "silicon drive" (NEC's term for a nonvolatile RAM disk), an internal ROM disk with DOS 3.3 (from which you boot the machine), and a "card drive." That's right, a card drive: a narrow slot on the right side of the machine that accepts ROM cards—measuring 3⅜ by 2⅝ inches and about ⅛ inch thick—each capable of holding between 512K bytes and 1 megabyte. The liquid crystal display is backlit (electroluminescent), so you don't have to find elusive perfect lighting.

Of course, NEC told us that it anticipates numerous applications to be converted to the

THE FACTS

NEC Ultralite
With 1-megabyte silicon
drive: \$2999
With 2-megabyte silicon
drive: \$3699

Packaged with:
DOS 3.3, Microsoft's
DOS Manager, and
LapLink.

NEC Home Electronics
1255 Michael Dr.
Wood Dale, IL 60191
(312) 860-9500
Inquiry 851.

NEC ProSpeed 386
\$7699

Features:
A 16-MHz 80386
portable with 2 megabytes
of 32-bit 100-ns RAM,
a 1.44-megabyte 3½-inch
floppy disk drive, and
a 40-megabyte hard disk
drive; with 100-megabyte
hard disk drive, \$8999.
The docking station
costs an additional
\$1199.
Inquiry 852.

ROM-card format. (The unit we received came with two ROM cards, one holding Traveling Software's LapLink, the other Microsoft Word.) The machine will also come with Microsoft's DOS Manager—a kind of window-based shell for user-friendly file management—and LapLink, the premier utility for moving files from machine to machine through serial ports.

Across the back, you'll find a 9-pin DIN-style connector for the RS-232C port, two modular phone jacks for the internal Hayes-compatible 2400-bit-per-second modem, a 7-pin DIN connector for the

external power pack, and a bizarre multipin connector (it looks like a miniature Euro-card connector) for an external 3½-inch floppy disk drive (optional).

The model I reviewed was an engineering version—and how. The internal RAM drive would not work, and I couldn't get the ROM cards to behave long enough to execute any programs from them. I did manage to attach the external drive and run from the floppy there. The external drive connector carries power as well as signals, so the drive itself doesn't need a power cable or an AC adapter. The screen

suffered from more ghosting (the partial activation of pixels along the same horizontal or vertical coordinate as an intense graphic) than I would have expected, though I could usually reduce the effect with the contrast slider.

I ran BYTE's low-level CPU benchmarks to get a feel for the Ultralite's performance. Though the machine is using an NEC V-30 processor (8086-compatible) running at 9.54 MHz—only twice the speed of a standard 4.77-MHz IBM PC XT—there's more going on than just a hike in the clock speed, because the Ultralite executed the benchmarks an average of 4.2 times faster than the XT. (This agrees well with the Norton SI, which awards the Ultralite a rating of 4.5.)

On the user-friendliness scale, I'll give the Ultralite high marks for portability. An MS-DOS machine with no-moving-part drives and a backlit display with dimensions as svelte as the Ultralite's is every mobile computer user's dream. But an Ultralite with a 1-megabyte silicon drive is \$2999, and a 2-megabyte version runs \$3699. When \$700 can get me a Toshiba laptop with an 80-column display (with no backlighting, true) and a 720K-byte floppy disk drive... hey, to save \$2300, I'll find a lamp and live with the disks.

—Rick Grehan

Computer Shuttlecraft

The NEC ProSpeed 386 (in above photo at left) is a pseudoportable; it's designed to give you a home base to which you regularly return the machine. NEC calls this home

continued

...the first completely integrated Ada Programming Support Environment priced for the individual programmer on a PC. Designed for the novice as well as the software engineer.

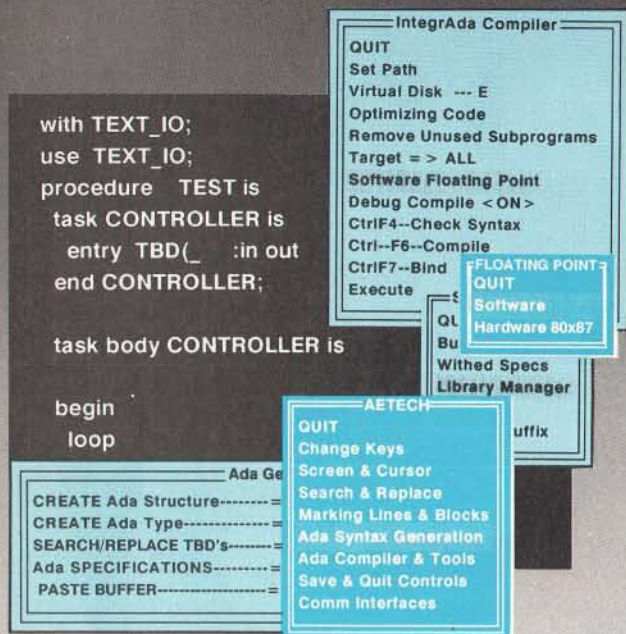

The screenshot shows the IntegrAda Compiler interface. On the left, there is a code editor with the following text:

```
with TEXT_IO;
use TEXT_IO;
procedure TEST is
  task CONTROLLER is
    entry TBD( :in out
  end CONTROLLER;

  task body CONTROLLER is

begin
  loop
```

On the right, there are several menu windows:

- IntegrAda Compiler:**
 - QUIT
 - Set Path
 - Virtual Disk --- E
 - Optimizing Code
 - Remove Unused Subprograms
 - Target = > ALL
 - Software Floating Point
 - Debug Compile < ON >
 - CtrlF4--Check Syntax
 - Ctrl--F6--Compile
 - CtrlF7--Bind
 - Execute
- FLOATING POINT:**
 - QUIT
 - Software
 - Hardware 80x87
- AETECH:**
 - QUIT
 - Change Keys
 - Screen & Cursor
 - Search & Replace
 - Marking Lines & Blocks
 - Ada Syntax Generation
 - Ada Compiler & Tools
 - Save & Quit Controls
 - Comm Interfaces
- Library Manager:**
 - Withd Specs
 - Library Manager

At the bottom left, there is a list of menu options:

- CREATE Ada Structure
- CREATE Ada Type
- SEARCH/REPLACE TBD's
- Ada SPECIFICATIONS
- PASTE BUFFER

- Validated Production Compiler
- Use on 8086,80186,80286,80386.
- Full 640KB .EXE Programs
- No Extra Memory Required
- No Math Coprocessor required.
- On-Line Library Management
- Math, Text, Console Packages included
- Multiple File Code Retrieval
- Full-Color, Full Featured Editing
- Selectable Function Keys
- Ada Subprogram and Package Generation
- Ada Type Generation
- Ada Sensitive Cursor
- Interactive Cursor Error Correction
- Interface to Ada Design Language (ADADL)
- Ada Standard Pretty Printer
- DoD 2167 Documentation Features
- Optional On-Line Ada Training Course
- No Run-Time Royalties

AETECH 380 Stevens Ave, Suite 314,
Solana Beach CA.92075
(619) 755-1277 FAX (619) 755-7540

"...the first choice among the half dozen or so compilers now on the market" — PCWEEK



Introductory Offer **\$495**

base the "docking station," and I'll describe it in detail later. Not that you couldn't operate the ProSpeed 386 indefinitely without the docking station; it would make a fine portable 80386 machine all by itself.

Let me rattle off the stats: a switchable 8-MHz/16-MHz 80386; support for an 80387 math coprocessor; 2 megabytes of 32-bit 100-nanosecond memory (standard), expandable in two upgrade paths to a maximum of either 4 or 10 megabytes; a cold cathode fluorescent technology (CCFT) backlit display (11 inches diagonal) that supports EGA, double-scan CGA, or Hercules; an internal 1.44-megabyte 3½-inch floppy disk drive; and your choice of a 40- or 100-megabyte internal hard disk drive. This all fits in an 18-pound case that measures 15½ by 4 by 13½ inches.

If the CCFT display doesn't float your boat, you can pop it off, hook your favorite PS/2 color or monochrome display to a connector in the back, and run VGA graphics (the ProSpeed will also accept a multi-sync monitor). And if there are still not enough options on-board, you can slide an internal 2400-bit-per-second modem into the special expansion boards into the LTX slot, an "IBM PC AT-like" (though not AT-compatible) connector that you access through a snap-off door on the right of the machine. (At the time of this writing, NEC said that three cards for the LTX slot were already under development: an Ethernet card, a Token Ring card, and a 3270 interface card.)

Of course, ProSpeed provides the standard I/O ports: an RS-232C serial connector (9-pin AT-style) and a PC-standard 25-pin parallel printer port, both in the rear, of course. Around back, you'll also find a connector for NEC's "battery slice," a 3-pound add-on battery pack that hooks to the rear of the machine for 2 to 3 hours of op-

eration away from a wall outlet. (Unfortunately, there was no battery slice available for the system I tested.)

The back is also home to the 120-pin connector that hooks the machine to the docking station I mentioned earlier. The docking station, which is slightly bigger than a big shoebox, comes with accommodations for three full-size 16-bit (AT) expansion cards, one full-size 8-bit expansion card, and two half-height drive bays that you can populate with your choice of floppy disk drives, hard disk drives, tape drives, and so on.

The docking station also extends the ProSpeed's I/O ports—parallel printer, serial, VGA, and RJ-11—to its own rear and adds a second serial port, another RJ-11 connector, and a keyboard port for an external keyboard. Inside the docking station is a 200-watt power supply that runs not only the components within the station, but the docked ProSpeed as well.

The docking station is a no-muss-no-fuss expansion bay. You sit at your desk, ProSpeed mated with its docking station, using piles of megabytes, an eye-pampering VGA display, and all the special-purpose adapter boards you can stand. Then, when it's time to hit the road, simply detach the ProSpeed, reattach the CCFT display, grab a cable or the battery slice, and drive off into the sunset. When you return, just hook the ProSpeed back to the station; you don't have to worry about reattaching a nest of power cables, video cables, and is-this-a-serial-or-parallel-printer?-cables.

In preliminary tests using BYTE's 80386 Small-C benchmarks, the ProSpeed actually scored marginally poorer than a 16-MHz PS/2 Model 80 on the CPU tests. On average, the ProSpeed ran at about 85 percent of the speed of the Model 80. Also, though the low-level hard disk drive test showed the ProSpeed's

continued



Embedded systems designers have already used CrossCode C in over 291 different applications.

How to choose a 68000 C compiler for your ROMable code development

These twelve important CrossCode C features could make the difference between success and failure

It's hard to know ahead of time what features you'll be needing in a 68000 C compiler. But if you're using CrossCode C you won't need to think ahead, because CrossCode C is already equipped with these twelve important features for your ROMable code development:

1. A 100% ROMable Compiler: CrossCode C splits its output into five memory sections for easy placement into ROM or RAM at link time.

2. Integrated C and Assembler: You can write your code in any combination of C and assembly language.

3. Readable Assembly Language Output: The compiler generates assembly language code *with your C language source code embedded as comments*, so you can see each statement's compiled output.

4. Optimized Code: CrossCode C uses minimum required precision when evaluating expressions. It also "folds" constants at compilation time, converts multiplications to shifts when possible, and eliminates superfluous branches.

5. Custom Optimization: You can optimize compiler output for your application because you control the sizes of C types, including pointers, floats, and all integral types.

6. Register Optimization: Ten registers are reserved for your register variables, and there's an option to automatically declare all stack variables as *register*, so you can instantly optimize programs that were written without registers in mind.

7. C Library Source: An extensive C library containing over 47 C functions is provided in source form.

8. No Limitations: No matter how large your program is, CrossCode C will compile it. There are no limits on the number of symbols in your program, the size of your input file, or the size of a C function.

9. 68020 Support: If you're using the 68020, CrossCode C will use its extra instructions and addressing modes.

10. Floating Point Support: If you're using the 68881, the compiler performs floating point operations through the coprocessor, and floating point register variables are stored in 68881 registers.

11. Position Independence: Both position independent code and data can be generated if needed.

12. ANSI Standards: CrossCode C tracks the ANSI C standard, so your code

will always be standard, too.

There's More

CrossCode C comes with an assembler, a linker, and a tool to help you prepare your object code for transmission to PROM programmers and emulators. And there's another special tool that gives you symbolic debugging support by helping you to prepare symbol tables for virtually all types of emulators.

CrossCode C is available under MS-DOS for just \$1595, and it runs on all IBM PCs and compatibles (640K memory and hard disk are required). Also available under UNIX & XENIX.

CALL TODAY for more information:

1-800-448-7733

(ask for extension 2001)

Inside Illinois or outside the United States, please dial

PHONE: 1-312-971-8170

FAX: 1-312-971-8513

SOFTWARE DEVELOPMENT SYSTEMS, INC.
DEPARTMENT 21
3110 WOODCREEK DRIVE
DOWNERS GROVE, ILLINOIS 60515 USA

CrossCode™ is a trademark of SOFTWARE DEVELOPMENT SYSTEMS, INC. MS-DOS® is a registered trademark of Microsoft. UNIX® is a registered trademark of AT&T. XENIX® is a registered trademark of Microsoft.

What you've been doing.



*On your 286,
you've been making any task look complicated.*



*On your 386,
it hasn't been incredibly exciting having all that power.*

If the screens on the right look more intriguing to you than those on the left, you're ready for Microsoft® Windows.

Windows opens up the world of visual thinking to all 286 and 386 owners by offering the power of graphics.

Everything you can do on your PC, you can now do better, faster and with greater imagination. Whether you're creating documents or trying to get a clearer picture of your work.

What used to take complicated key-strokes can now be accomplished with the simple click of a mouse. With Microsoft Windows, you access pull-down menus. Simultaneously work with different programs as well as cut and paste between them to create graphic examples within different bodies of text. And what you see on the screen will appear on your printed page.

And once you've learned Microsoft Windows, you'll have the basis for scores of other programs because all the countless new Windows applications are based on the same easy, logical format.

Since Microsoft Windows virtually looks and works like MS® OS/2 Presentation Manager, you won't have to worry about it becoming obsolete in a couple years. We made both systems compatible. So, in the future, you'll be able to share

data between them. And your knowledge of Windows will give you a jump on learning MS OS/2 Presentation Manager.

You'd expect a program this powerful to require a more powerful machine. But we consistently create software that makes

Stop playing with ancient instruments. Now cutting and pasting is a simple point and click with the Microsoft Mouse.

What you could have been doing.



With Windows/286,
you could have been seeing things much more clearly.

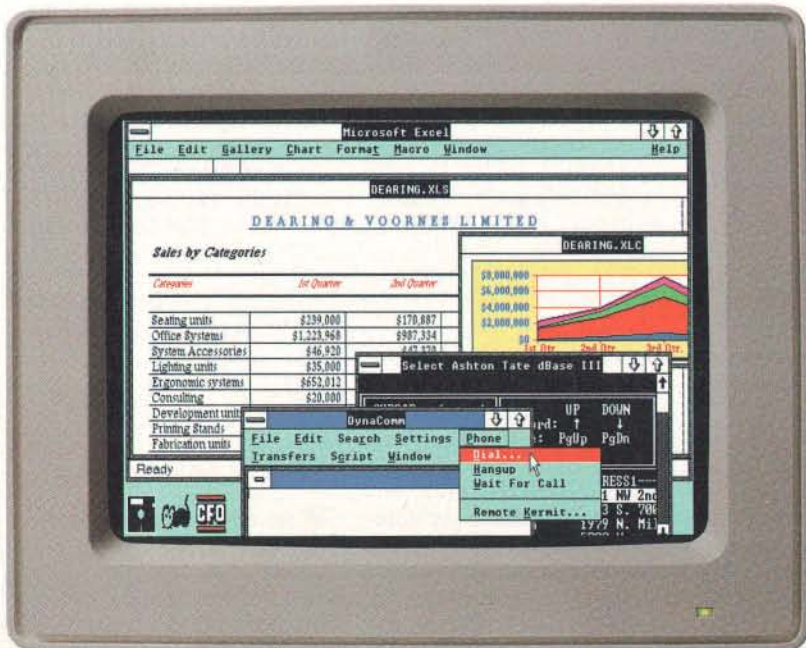

With Windows/386,
you could have been seeing a lot more things much more clearly.

the best use of your present hardware.

For example, Microsoft Windows/286 will work with as little as 640K and instantly make your machine more sensitive, intuitive and highly visual. It gives you the ability to run every Windows application available.

And with access to all those powerful programs, you'll be able to extend the life and usefulness of your 286 well beyond the introduction of MS OS/2 Presentation Manager. With version 2.1 you also get the benefit of increased speed. So you'll blaze through Windows applications up to 87% faster.

Microsoft Windows/386 will give you everything that Windows/286 gives you. Plus multitasking with most DOS applications. Now you can finally utilize the speed and power of any 386 machine.

Imagine creating a complicated spreadsheet. Then while a macro is being run, open up a word processor. Type a document, open and work with a graphics program. Cut and paste between programs and even call up electronic mail. And still be able to check on the status of your spreadsheet at any time.

Considering all you can do with Microsoft Windows, you have only one question to ask yourself.

What have you been doing without it?

Microsoft®

hard disk drive to be slightly faster than the Model 80's, the File I/O, 1-megabyte File Read, and 1-megabyte File Write benchmarks all turned in marginally poorer figures than the Model 80's (the NEC ran at about 90 percent of the Model 80's speed).

At a price of \$7699, the NEC ProSpeed costs more

than a Toshiba T5100, but it offers the added capabilities of VGA graphics and a larger internal hard disk drive. On the downside, the ProSpeed weighs 3 pounds more than the Toshiba, and its 80386 isn't as zippy (at the same speed as the Toshiba).

Whether or not the concept of the docking station will

catch on remains to be seen. I wonder how many people actually need the kind of arrangement the ProSpeed offers. Perhaps for some computer users, the cost of an 80386-based system is still too high to permit purchasing two complete systems, a home base and a portable. But how many people must have an

80386 in their portable? Most folks I know survive with an 80286 or even an 8088 in their laptops and save the big bucks for a PS/2-style tower on the floor next to their desks. But if you have to take your 80386 with you and like the idea of expanding it at home, the ProSpeed may be your machine.

—Rick Grehan

A Promotion for Commander Norton

That puzzling C: prompt that stares you in the face every time you start up your MS-DOS system has sparked a bevy of companies to develop so-called DOS shells that supposedly make DOS easier to use. Over the years, I've tried and rejected most of them. With few exceptions, these shells shoehorn you into one person's view of what the DOS interface should be. I seldom agree.

I've been a regular and enthusiastic user of **The Norton Commander** since it was first released almost 3 years ago. And when the update (version 2.0) arrived on my desk, I had the envelope ripped open and the software installed on my system in a matter of minutes. Happily (and not unexpectedly), the Norton folks have made a useful product nearly indispensable.

What I've always liked about The Commander is that it can be as helpful or as nonintrusive as you wish. Although your screen is filled with useful information, the old standard C: prompt is still there. You can enter normal DOS commands anytime you wish, just like The Commander wasn't there. Aptly, the Norton folks like to call The Commander a "DOS extender and enhancer" instead of a DOS shell.

The program is still based on twin panels that can contain alphabetical lists of files or other information. You can

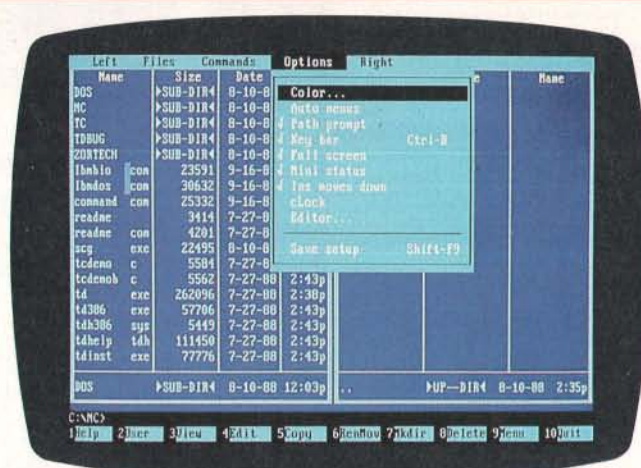

THE FACTS

The Norton Commander 2.0
\$89

Requirements:
IBM PC, XT, AT, or
PS/2 with DOS 2.0
or higher.

Peter Norton Computing,
Inc.
2210 Wilshire Blvd.
Suite 186
Santa Monica, CA 90403
(213) 453-2361
Inquiry 856.

turn individual panels on or off or change their information. In version 2.0, the panels have been extended downward to fill nearly the entire screen, the better to see more files at a glance. And if you have an advanced display, you can see even more: 43 lines on an EGA display and 50 on a VGA.

Peter Norton Computing has added a long list of other new features to version 2.0—in fact, too many to cover in my limited space. But for a start, there's an optional graphical tree display of your disk's subdirectory structure; switching to a different directory is a simple matter of pointing at a tree entry and pressing Enter.

And I wasn't surprised to find that in addition to direct commands, almost all the new features are on those ubiquitous pull-down menus we've all grown to know and love.

What else? One of the handiest features lets you directly view the contents of Lotus 1-2-3 and dBASE data files without having to start up the respective programs. There's also a fast new file-find feature that lets you view files while The Norton Commander is still looking for additional matches.

Though the program doesn't require it, you need a mouse to get the most out of The Commander. With a ro-

dent, it's amazing how quickly you can move around and get things done through strategic "pointing and shooting."

With source code consisting of some 32,000 lines of C and 15,000 lines of assembly language, this isn't a trivial program, and using the full-fledged memory-resident version takes up 140K bytes of your precious RAM space. If space is really tight, you can also use The Commander with a tiny 12K-byte resident kernel that calls the rest of the program when it's needed.

At \$89, The Norton Commander 2.0 is fairly priced, and it's a program you'll use all day, every day. In my case, it's the only survivor of the numerous applications and utilities I had on my system 3 years ago. And version 2.0 is likely to stay there for a long time.

—Stan Miastkowski

Compaq's 20-MHz 386er Slims Down

The new **Compaq Deskpro 386/20E** (E for "enhanced") has the brains of a Deskpro 386/20 in the stylish new body of a Deskpro 386s (the sleek system based on Intel's 80386SX processor). And it's a nice body—taller and narrower than the original Deskpro box, with a rounded beige case that's clearly modeled after the IBM PS/2s. At just under 16 inches wide and 15 inches deep, it covers the

continued

All the excitement of the Air Force, without shaving your head.

You have a choice:

You can take flight school, about a year of it, get your pilot's license and *then* enjoy the sensation of landing at O'Hare at midnight or catching a bird's-eye view of the Statue of Liberty.



New Microsoft Flight Simulator. It's not a game. It's an adventure.

Or you can do it on a PC. This afternoon. In your office. With the new Microsoft® Flight Simulator® version 3.0.

New as in the most realistic flight simulator available on the PC. New as in a choice of *three* different planes: Lear Jet, Cessna Turbo 182 or WWI Top Gun.

Weather conditions? You decide: Calm, turbulent, sunny, cloudy. Yes, you'll see lightning. Enough to make the whole plane shake.

Flight Simulator also lets you glide, loop, spin, attack, roll out or just cruise inside 10,000 square miles of airspace. And if flight school didn't teach you how, this will. On screen.

Plus it's the *only* simulator with a modem hookup so you can fly with a friend. And check each other out, right from your own screens.

For a heavy dose of reality, go see Flight Simulator 3.0 at your local Microsoft dealer. If that isn't exciting enough?

Go see your local recruiter.

Microsoft®

©1988 Microsoft Corporation. Microsoft and the Microsoft logo are registered trademarks of Microsoft Corporation. Flight Simulator is a registered trademark of SubLOGIC Corporation, used under license by Microsoft Corporation.



One cockpit, two windows: One shows where you are in the sky. One shows where you are in the country.

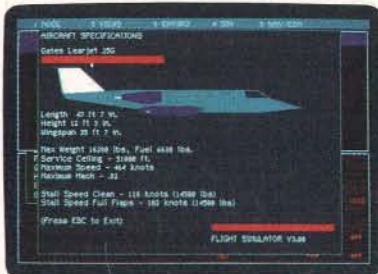

Complete on-screen aircraft library shows detailed specs on all three planes: Lear Jet, Cessna Turbo 182 and WWI Top Gun.



Try this: Hook up our phone modem and head into the wild blue yonder with a friend. Day or night.



Keep your eyes peeled for balloons, towers, mountains, buildings, bridges, you name it. Welcome to the real world.



Nervous? Relax, new Flight Simulator teaches you, on screen, how to do everything... except bail out.

ENGINEERS . . .

**Stop Banging
Your Head Against
The Ceiling And
Give Us A Call
TODAY!**



MODEL PCSS-8I INTELLIGENT SERIAL BOARD

- ★ Our most powerful serial card to date.
- ★ 8 Co-processor driven channels per card.
- ★ Each channel is queue'd on the card.
- ★ BIOS Enhancement Software included, supporting up to 130 channels per computer.
- ★ Baud rates to 57.6k on a half size card.

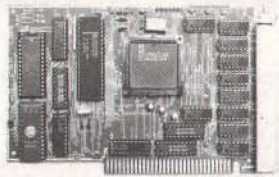
**NEW!**

MODEL PCSS-8X MULTIPOINT SERIAL BOARD

- ★ Eight RS232 ports per card. (optional 4 port)
- ★ All eight ports 100% DOS compatible.
- ★ 32 ports may be added to a PC.
- ★ Optional RS422 to 4000 ft.
- ★ Interrupt driven BIOS Enhancement Software included free.

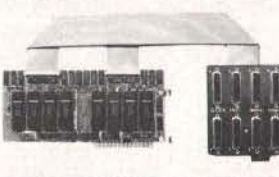
**NEW!**

MODEL ROMX-2XL EPROM EMULATOR

- ★ Emulates 2716-27010 eproms.
- ★ 256K to 1024K memory available.
- ★ Battery backed up, auto emulate on power-up.
- ★ Low-cost, pays for itself on first project.
- ★ Free 19.2K Serial Communications Software.

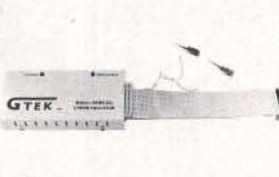
**NEW!**

MODEL 9000 (E)EPROM PROGRAMMER

- ★ Fastest programmer on the market.
- ★ Quick & Intelligent programming algorithms.
- ★ Programs all chips, to one megabit, including single chip processors.
- ★ Programs largest variety of chips including Prom replacements, Eproms and EEPROMs.



THE FACTS

Compaq Deskpro 386/20E
\$5199 with a floppy disk drive; \$6599 with a floppy disk drive and a 40-megabyte hard disk drive; \$7999 with a floppy disk drive and a 110-megabyte hard disk drive

Compaq Computer Corp.
20555 FM 149
Houston, TX 77070
(713) 370-0670
Inquiry 854.

same area as a PS/2 Model 50. The power switch is on the front of the computer, and there's a 1.2-megabyte 5¼-inch floppy disk drive, with room for another floppy disk drive (either 5¼- or 3½-inch) and a tape backup unit for a hard disk drive.

Like the PS/2s, the Deskpro 386/20E has a case that opens with a turn of a few thumbscrews (though there's also a mechanical lock to secure the system), and floppy and hard disk drives come out easily with a screwdriver.

Inside the box, the computer merges the strengths of the 386s and the 386/20. From the 386/20 comes an 80386 processor running at 20 MHz and a megabyte of 100-nano-second RAM, complete with caching—32K bytes of 35-ns static RAM run by an Intel 82385 cache memory controller. Compaq claims the cache system lets the 386/20E run with no wait states more than 90 percent of the time. There are also sockets for either a Weitek 3167 or an Intel 80387 floating-point coprocessor.

The 386/20E doesn't represent any performance breakthroughs. Compaq representatives say it runs in the same range as the older model, and BYTE's CPU benchmarks bear that out. The new machine is a little faster on the Sieve and Sort benchmarks and slightly slower on the Matrix and String Move benchmarks, but on average, there's

no real change, and the 386/20E is still faster than 20-MHz PS/2s. The on-board VGA controller should improve graphics speed, though. Compaq claims its graphics run up to 50 percent faster than a standard VGA card. If you're not satisfied with VGA, a switch on the motherboard lets you use a graphics card in one of the available slots.

The 386/20E also has all the nice features that are on the 386s motherboard: VGA graphics, mouse circuitry, a parallel printer port, a serial communications port, and a floppy disk controller. A Compaq memory-expansion slot accepts the same memory card and modules as the earlier Deskpro machines; in the case of the 386/20E, you can increase RAM to 16 megabytes. And there's space for a pair of hard disk drives of capacities of 20, 40, or 110 megabytes.

Cramming the processor and support circuitry on a 386s-size motherboard was a challenge for Compaq's engineers; it's the densest board they've ever created, 10 levels deep and very tightly designed. Unfortunately, while they managed to fit in all the functionality (and more) of the old Deskpro 386/20, there was no way to include all the slots of the original.

The 386/20E has only four AT-compatible slots, one of which will typically be tied up with a hard disk controller card. As with the PS/2s, you don't need parallel, serial, floppy controller, or graphics cards; Compaq's advantage is that memory cards won't use up slots either, but some people will still be unhappy with the slot shortage.

The Deskpro 386/20E is going head-to-head with the PS/2 line. The new high-density motherboard has everything IBM added to its PS/2 motherboard—but with more slots available, particularly after memory upgrades. The 386/20E is still significantly faster than any 20-MHz PS/2. Com-

continued

GTEK INC.

Development Hardware & Software
P. O. Box 2310
Bay St. Louis, MS 39521-2310
Order Toll Free 1-800-255-GTEK (4835)
Fax: 1-601-467-0935 Telex 315814 (GTEK UD)
MS & Technical Support 1-601-467-8048

Leprecard Hard Disk Cards

Leprecards feature components utilizing the latest technology. Low power drives mean less strain on your systems, lower operating temperature, and longer component life. You get a 1 year warranty, unlimited technical support, and our illustrated installation and user's guide. Models available for IBM PC/XT and compatibles, as well as TANDY 1000/A/SX/TX/TL/SL.

FREE SOFTWARE Including TakeTwo, the backup utility PC MAGAZINE named Editors Choice in 1986 & 1987, and PC-KWIK disk caching from Multisoft.

21MB 48ms	32MB 48ms	40MB 70ms*	49MB 28ms*	65MB 16ms*
\$299	\$339	\$449	\$549	\$649

* Average access speed per partition

Tandy 1000/A/SX/TX/TL/SL Leprecards add \$20

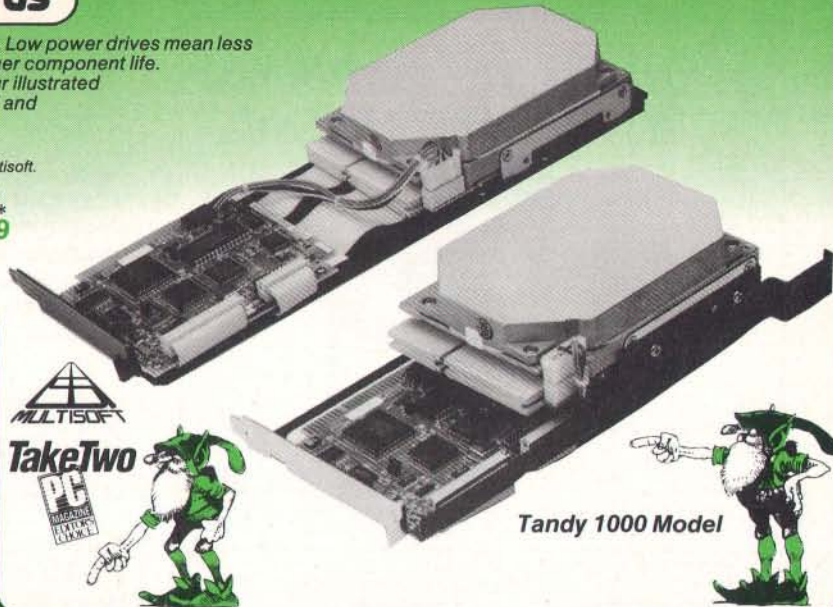

Tandy 1000 Model

3.5" Floppy Kits

Internal kits for PC/XT/AT computers include 5 1/4" mounting brackets, black & gray face plates, and AT rails. 1.44MB for PC/XT includes high speed Western Digital controller.



FREE TAKE TWO floppy backup software.

720 Kit	1.44MB for AT	1.44MB for PC/XT
\$109	\$139	\$199



TakeTwo



PC/XT Disk Kits

- Pretested & formatted
- Western Digital short slot controller
- 30 page installation guide & reference manual
- Cables, mounting screws, full & half-height face plates
- 1 year Warranty, 30 Day Money Back Guarantee
- Optional: 150 watt, UL/FCC approved power supply for IBM PC's \$69

20MB KIT	\$279
• Seagate ST225 - 21.4MB/65ms. Half-Height/14.8 watts	
30MB KIT	\$299
• Seagate ST238 - 32.7MB/65ms. Half-Height/14.8 watts	
40MB KIT	\$459
• Seagate ST251 42.8MB - Half-Height - 11 watt • pre formatted into a pair of 21MB/28ms partitions.	
65MB KIT	\$549
• Seagate ST277R 65.5MB - Half-Height - 11 watts • pre formatted into a pair of 32MB/28ms partitions.	

FREE SOFTWARE including TakeTwo, the backup utility PC MAGAZINE named Editors Choice in 1986 & 1987, & PC-KWIK disk caching from Multisoft.



Tandy 1000 kits add \$20

Laser Printer

"One of the Laserjet's strongest competitors"
INFOWORLD October 5, 1987

512K	1.5MB
\$1495	\$1595

- Printer utility software
- Serial and Parallel Interfaces
- 120 day TRW on site maintainance
- 1 year Warranty
- 100% HP Laserjet, & Laserjet + compatible
- 9 resident & 5 downloadable soft fonts standard
- Options: All HP style font cartridges



Toner Cartridge \$29

AT Hard Disk Kits

- Includes IBM AT rails, and cables.
- SpeedStor or Ontrack large drive software.
- Formatted, Partitioned & Tested.

SIZE	MODEL	SPEED	CAPACITY	PRICE
HH	Seagate ST251	40ms	42MB	\$359
HH	Seagate ST251-1	30ms	42MB	\$449
HH	Toshiba Drive MK134	25ms	44MB	\$499
FH	Seagate ST4096	28ms	80MB	\$599
FH	Maxtor 1140	27ms	117MB	\$1669
FH	Maxtor 2190	30ms	150MB	\$1999

LepreFAX Modems

- Easy to use POP-up Menus
- Sends ASCII or word processing files
- Internal 4800bps, \$289 9600bps \$559
- Prints on standard dot-matrix or laser printers
- Sends/Receives from any Group 3 fax machine
- Automated sending during low phone rate periods
- Portable external plugs into PC/XT/AT serial port, \$359

External
\$359

Internal
\$289



4" Hand Scanner with HALO DPE software \$269

2400 Modems

with MNP

External **\$239** Internal **\$229**

Hayes Compatible, 300/1200/2400 MNP Level 4 error correction
FREE MIRROR II Software, a \$69 value
Internal model \$229, fits in a short slot

2400 without MNP **\$159** Ext **\$109** Int



Orchid

Designer VGA 512K	\$299
Orchid VGA 256K	\$249
Tiny Turbo 286	\$289
Ramquest II 1MB	\$799



\$895

286¹⁰ Computer

80286 processor running at 6/10 Mhz with 0 wait states provides a Norton SI rating of 11.5. 8 slots - Room for 1 full and 3 half-height drives-220 watt power supply - clock/calendar - Choice of 1.2 or 1.44MB floppy drive-Genuine Western Digital combination Hard disk/floppy controller-American made Maxiswitch 84 or 101 key keyboard - 512K RAM standard expandable to 1MB Award BIOS- 1 year warranty - 30 day money back guarantee.

Complete systems with serial & printer ports:

Mono/Graphics Card & Monitor	\$1095	Orchid VGA Card & Multiscan Monitor	\$1595
VGA Card & Mono Monitor	\$1295	Orchid Designer VGA Card & NEC Multisync II Monitor	\$1895
EGA Card & EGA Monitor	\$1495		



2524B Townsgate Road, Dept. B, Westlake Village, CA. 91361



To order, or get our free catalog call

Toll Free
800 722-AT-XT
California
805-373-7847
FAX
805-379-9345

MEMBER
MMC
MICROCOMPUTER
MARKETING COUNCIL
of the Direct Marketing Association, Inc.

- No extra for Visa/Mastercard (AMEX add 3%)
- Prices include UPS surface shipping
- Federal Express shipping just \$1.50 per pound
- 30 Day Money Back Guarantee
- Corporate & Institutional PO's accepted

PROTECT INTELLIGENCE WITH INTELLIGENCE



SOFTWARE PROTECTION KEYS BY PROTECH

PROTECH KEYS:

- are totally transparent to the end user
- allow unlimited back up copies
- free up disk drives
- do not interfere with peripheral operations
- are easy to install
- protect software developers' revenues
- assembler based routines (not drivers)
- encrypted routines
- physically unique hardware KEYS
- sophisticated software installation advice
- provide the highest level of protection available

THE KEY

The KEY provides effective software protection while insuring customer satisfaction. The KEY is a random response device which is designed for identically reproduced software packages.

THE MEMORY KEY

The MEMORY KEY is a programmable software protection device. Each byte of memory can be addressed in groups or individually. Possible applications for the MEMORY KEY include:

- modular package control
- serialization
- customization
- access control to PCs
- demo control
- software leasing
- updating modules in the field
- any "counter" operation

For a demonstration package or additional information, please write or call:

1-800-843-0413

PROTECH MARKETING, INC.
1804 W. Southern Parkway • Bldg. A-112
Durham, North Carolina 27707
(919) 490-4970 FAX (919) 490-4974

WE HAVE THE KEY TO SOFTWARE COPY PROTECTION

SHORT TAKES

paq continues to hammer away with what it views as its biggest advantage over the PS/2: the variety and availability of AT-bus expansion cards, and the limited selection of Micro Channel cards. And now

Compaq is competing on good looks, too. Although the 386/20E isn't a significantly different machine, it does say something about Compaq's response to the PS/2s.

—Frank Hayes

A Measure of Success

I kept seeing shadowy images of Big Brother as I put **Personal Measure**, a performance analysis package, through its paces. As you go about your work on the computer, **Personal Measure** monitors your every keystroke, analyzing the effectiveness of your system and the efficiency of your task.

But personal fears aside, **Personal Measure** performs a noble feat. It analyzes the performance of your IBM PC compatible and of your software from a real-world perspective. You need only develop repeatable scenarios based on work actually performed. Once you've settled on a scenario, just turn **Personal Measure** on. The terminate-and-stay-resident (TSR) program works in the background, monitoring the flow of information through the software interrupt vectors. The resulting statistical data and color graphs show how system resources are allocated for the selected task.

When you run the analysis module, you can graph an entire event, a portion of it, or the performance of a particular program. The graph displays the blend of resources employed throughout the event cycle. **Personal Measure** maps usage of the processor, disk drive, keyboard, printer, and auxiliary resources. Tables assign a percentage of the total time to each resource as well as clocking total time duration for each resource. A disk activity summary lists the number of file reads, file writes, programs loaded, directory accesses, and non-DOS accesses performed during the selected event.

This data is useful stuff. You can clearly see how resources are used for each application. You can determine if a particular task floods the disk or requires heavy keyboard input. If you're looking for a new system, you should base that decision on the applications you'll be using most. **Personal Measure** will take some of the guesswork out of that equation. If your application employs the processor 90

continued

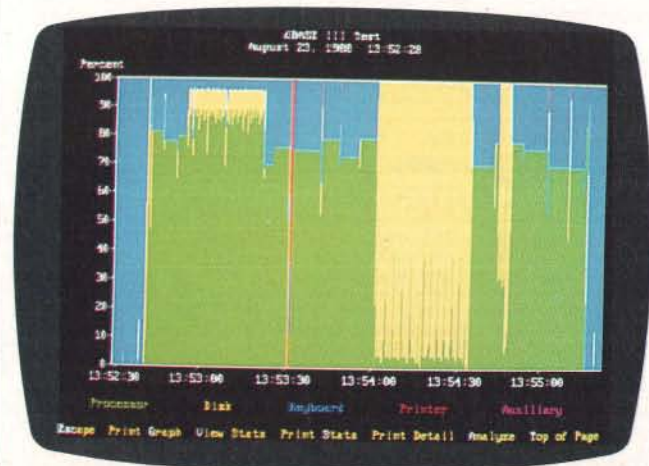

ABRA 2000



ABRA 2000

only \$995 for IBM PC & Macintosh

Human Resources

Magically cuts paperwork and saves time. Prepares accurate personnel reports instantly!

The ideal solution for most personnel needs:

- Complete Employee Record Keeping.
- Salary Reviews, Job History & Salary Analysis.
- Benefit Statement, Insurance & COBRA Reports.
- EEO Reports, I-9 Tracking, Injuries & Licenses.
- Organizational List, Phone Directory & Birthdays.
- Skill Retrieval, Education, Training & much more.
- Over 50 Reports, plus optional report writer.
- Attendance Tracking & Multi-User options.
- **New Applicant Tracking System available.**

Easy to use — even for novices. And ABRA 2000 is "proven" with over 800 happy customers.

It's not an illusion... Test the magic!

Call Today or Send \$25 for Demo and Manual.

ABRA Cadabra
SOFTWARE

5510 - 9th Street North, St. Petersburg, FL 33703 (813) 525-4400

Aztec C

*Power to go the distance...
Whatever that distance might be*



From real time embedded applications to comprehensive commercial applications on Macintosh, IBM PC, Amiga, Atari, and others, Aztec C has earned a well-deserved reputation as an innovative, tough to beat, rock-solid C development system.

But don't just take our word for it—try it yourself. We know that the best way to understand what puts you ahead with Aztec C is to use it. That's why Aztec C

systems purchased directly from Manx come with a 30-day, no questions asked, satisfaction guarantee. Call for yours today.

We can also send you information that details the special features and options of Aztec C. Plus information on support software, extended technical support options, and all of the services and specialized support that you may need when you're pushing your software to the limits and... beyond.

Aztec C Micro Systems

Aztec C is available for most micro-computers in three configurations: The Professional; The Developer; and The Commercial system. All systems are upgradable.

Aztec C68k/Am Amiga
source debugger—optional

Aztec C68k/Mac . . . Macintosh
MPW and MAC II support

Aztec C86 MS-DOS
source debugger • CP/M libraries

The following have special pricing and configurations. Call for details.

Aztec C68k/At Atari ST

Aztec C80 CP/M-80

Aztec C65 Apple II & II GS

Standard System \$199

- C compiler
- Macro Assembler
- overlay linker with librarian
- debugger
- UNIX and other libraries
- utilities

Developer System \$299

- all Standard System features
- UNIX utilities make, diff, grep
- UNIX vi editor

Commercial System \$499

- all Developer features
- source for run time libraries
- one year of updates

MS-DOS Hosted ROM Development Systems

Host + Target: \$750 Additional Targets: \$500

Targets:

- 6502 family
- 8080-8085-Z80-Z180-64180
- 8088-8086-80186-80286/8087-80287
- 68000-68010-68020/68881

Components:

- C compiler for host and target
- Assembler for host and target
- linker and librarian
- Unix utilities make, diff, grep
- Unix vi editor
- debugger
- download support

Features:

- Complete development system
- Fast development times
- Prototype and debug non-specific code under MS-DOS
- Compilers produce modifiable assembler output, support inline assembly, and will link with assembly modules
- Support for INTEL hex, S record, and other formats
- source for UNIX run time library
- processor dependent features
- source for startup

MANX

C.O.D., VISA, MasterCard, American Express, wire (domestic and international), and terms are available. One and two day delivery available for all domestic and most international destinations.

Manx Software Systems
One Industrial Way
Eatontown, NJ 07724

Aztec C is available on a thirty-day money back guarantee. Call now and find out why over 50,000 users give Aztec C one of the highest user-satisfaction ratings in the industry.

Call 1-800-221-0440

In NJ or outside the USA,
call 201-542-2121

Telex: 4995812 Fax 201-542-8386



NOW, who's in charge?

Now, with STAGEHAND you can create Advanced Screens for "C" programming environments without the tedious, time consuming and often expensive development. You are in charge with the ability to make your programs sing with colorful windows that display your data. Whether you are a manager coordinating a large project, a consultant or programmer trying to speed-up development time, STAGEHAND allows you to be in control.

What is a STAGEHAND without a STAGEMANAGER?

The STAGEMANAGER library, with its powerful functions, allows you to orchestrate the screens created by STAGEHAND. With the help of the STAGEMANAGER you can manipulate the screens to create Multiple Overlapping Windows, Scrollable Regions, Auto Scrolling Windows, as well as, a symphony of routine support features not found in other screen packages.

ACT NOW and receive PLAYWRITE at No ADDITIONAL CHARGE!

Unlike any other screen package you'll hear about, Datacode Inc. (Creators of STAGEHAND and STAGEMANAGER) will give customers the ability to create full featured demos with PLAYWRITE. For a limited time, we will include with your purchase of STAGEHAND, the PLAYWRITE advantage. With PLAYWRITE you can create a demo without the need to write any program code through the use of a powerful set of easy-to-use commands.

Call for a **FREE** Demo Disk

1(800)DATACODE

SPECIAL PACKAGE PRICE costs \$199.00, which includes FREE Updates, Telephone Support, STAGEMANAGER Source Code and, of course, there are No Royalties or Run-time Fees. Dealer Inquires Welcomed.

DCI

DATACODE INCORPORATED

1085 Rt.112, Port Jefferson Sta., N.Y. 11776 (516) 331-7848

percent of the time, perhaps you should consider raw processor speed above all other considerations. Or if you note heavy disk usage, a system with optimal interleave might make a better choice.

Personal Measure can also provide insight into selecting the most effective software, choosing the best upgrade path, or determining how to best allocate resources in a local-area network. You can even tailor your PC for optimum response by enhancing performance where it is most needed. For example, when the ratio of BIOS calls to DOS calls exceeds 1.2 for file reads, the program issues a message suggesting you reorganize your hard disk drive to reduce the effects of file fragmentation.

Unfortunately, some drawbacks curse this package. Because it taps the software interrupt vector to gather data, it cannot evaluate any program that bypasses the interrupt vectors in order to access devices. Such programs include Microsoft's Windows, Borland's SideKick, and Lotus's Express. And since Personal Measure stays resident, you must watch out for other TSRs running with it.

Personal Measure also balks at many low-level operations, like certain DOS activities (CHKDSK, BACKUP) and most Norton Utilities. You can even lose hard disk drive information if you run these programs with Personal Measure active. Spirit of Performance has included a disk file that lists known programs that Personal Measure will not run.

At first the program would not run properly on my Hercules-compatible AT clone. The company promptly sent a software upgrade that solved the glitch, but the ordeal exposed an inflexible installation routine. The software is easy to install, but that may be part of the problem. You can select an output port and a printer (Epson, Proprinter, or LaserJet), but that's it. If a configuration problem arises, you

have precious few parameters to tweak.

I also had some problems running the program on a Dell System 310. However, the system used an early version of the Paradise VGA card, and subsequent releases of Personal Measure do run the software. In any case, you should check with Spirit of Performance to confirm that the program runs with your specific machine. I ran it successfully on a true-blue AT, Compaq, PS/2, and ALR FlexCache.

This program could use some polish, like a more comprehensive setup menu and fuller documentation. The documentation offers general tips on ways to optimize your system, and one chapter explains the benchmarking suites available. More of the 58 pages should have been devoted to practical program operation. In any case, Personal Measure includes a 30-day money-back guarantee and limited 90-day telephone support. So make sure Personal Measure is compatible with your computer and your applications. If it is, your efforts, as well as your \$69.95 investment, will pay off.

—Stanford Diehl ■

THE FACTS

Personal Measure
\$69.95

Requirements:

IBM PC, XT, AT, PS/2, or true compatible with one of the following combinations of video adapter and display type: VGA color, VGA monochrome, EGA color, EGA monochrome, Hercules graphics, CGA, MCGA color, MCGA monochrome; DOS 2.0 or higher.

Spirit of Performance, Inc.

73 Westcott Rd.
Harvard, MA 01451
(508) 456-3889
Inquiry 855.

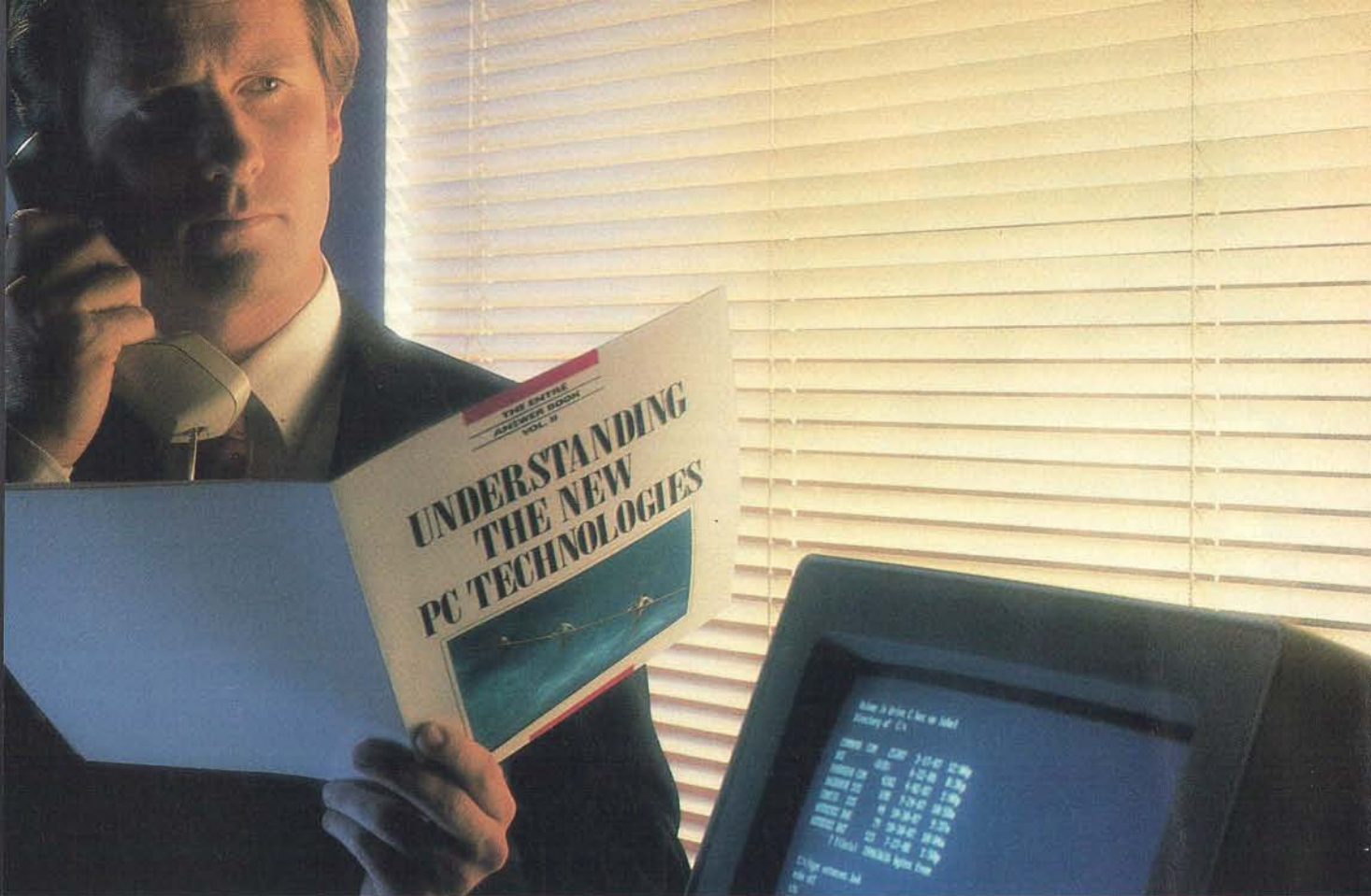

BECAUSE KNOWLEDGE IS POWER

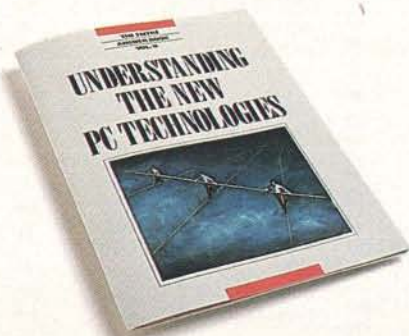

Get the facts you need about your next computer system with this free book.

...especially when it comes to new PC technologies. These advancements offer your company more system options than ever...and more chance of making expensive mistakes.

That's why Entré Computer Centers have put together a new book to help you make the right choices, for today *and* tomorrow.

Understanding the New PC Technologies will give you the latest word on OS/2, industry standard architecture, and MICRO CHANNEL* architecture. You'll find the facts you need about processor performance, graphic standards and portable solutions...and how the buying decisions you make today will affect your productivity tomorrow.

Best of all, it's yours FREE, compliments of Entré. The computer professionals who are dedicated to helping you make the right PC decisions.

To order your free book, mail the coupon or call toll-free 1-800-635-7500 ext. 92. Because whoever said "ignorance is bliss" never had to choose a computer system.

YES! Please send me my FREE book.

Entré Answer Book II
P.O. Box 3900
Peoria, IL 61614

For even faster service, call:
1-800-635-7500 ext. 92

NAME _____

BUSINESS NAME _____

ADDRESS _____

CITY _____

STATE _____ ZIP _____

() _____

PHONE NUMBER _____



The brains behind business computers.™

tele mart

SOFTWARE

DATA BASE MANAGEMENT

Clipper	\$409
dBase III Plus	369
dBase III LAN	599
DB-XL Diamond	107
Eureka	99
Genifer	188
Nutshell	72
Paradox 2.0	415
PFS: Professional File	119
Q & A	185
Q & A Write	105
Rapid File	182
Revelation	459
R:Base For DOS	425
Reflex	88
VP Expert	112
VP Info	56

PROJECT MANAGEMENT

Harvard Total Project Mgr. II	\$309
Microsoft Project 4.0	279
Timeline 2.0	259

WORD PROCESSORS

Easy Extra	\$53
Word (Microsoft)	179
Multimate Advantage II	259
PFS: Professional Write	102
Volkswriter 3	132
Volkswriter Deluxe Plus	57
Webster New World Writer	53
Webster Pro Spell Checker	32
Webster Thesaurus	37
Word Perfect 5.0	219
Word Perfect Executive	119
Word Perfect Library	59
Wordstar Pro Pack 4.0	Call
Wordstar 2000 Plus 3.0	Call

DESKTOP PUBLISHING

Newsmaster II	\$39
Pagemaker	489
PFS: First Publisher	65
Ventura Publishing	475

GRAPHICS

Energraphics	\$186
Freelance Plus	309
Generic CAD w/Dot Plot 3.0	72
Harvard Graphics 2.1	239
In-A-Vision	260
Microsoft Chart 3.0	223
News Room	30
News Room Professional	42
Printmaster Plus	29
PrintShop	32
Turbo Graphix Tool Box	58
VP Graphix	56
Windows Draw! w/Clip Art	159

MICE

PC Mouse w/Paint (Buss or Serial)	\$85
PC Mouse w/Autosketch (Buss or Serial)	99

Microsoft Buss Mouse 1.0	89
Microsoft Serial Mouse 1.0	91
MS Buss Mouse w/CADD	104
MS Serial Mouse w/CADD	104
MS Buss Mouse w/Windows	119
MS Serial Mouse w/Windows	121
Optimouse (PC Mouse) w/Dr. Halo III	78

INTEGRATIVE SOFTWARE

Ability Plus	\$137
Enable 2.0	352
Framework III	425
MS Works	84
PFS: 1st Choice	76
Smart Software System	389
Symphony	435

ACCOUNTING

ACCPAC Easy	\$53
Bedford Accounting	139
ACC PAC BPI	Call
DAC Easy Accounting	53
DAC Easy Payroll	53
In-House Accountant	105
One Write Plus 2.0	117
One Write A/R, A/P, Payroll	117
Time Slips III	109

UTILITIES

1 DIR Plus	\$46
Bookmark	56
Brooklyn Bridge	69
Carousel 2.0	43
Copy II PC	18
Copywrite	40
Corefast	85
Cruise Control	29
Disk Optimizer 2.0	38
Disk Technician	56
Double DOS 4.0	38
DS Back-Up Plus	46
Fastback	75
Fastback Plus	86
Keyworks	53
Laplink	69
Mace Utilities	47
Microsoft Windows 286	57
Norton Commander	43
Norton Editor	35
Norton Utilities 4.0	46
Note It Plus	45
PC Tools Deluxe	36
Printworks for Lasers	67
Referee	38
Sidekick Plus	115
Sideways	37
Smart Notes	43
SQZ Plus	53
Superkey	58
Unlock D Plus	49
Unlock Masterkey	95
XTree Professional	61

ACCESSORIES

Copy II Option Board Deluxe	\$99
Masterpiece	79
Masterpiece Plus	92
Masterpiece Remote	107
MousePad by Mousetrac	9
Summasketch 12 x 12 Plus	359

NOVELL

ANW/286 w/Key Card	\$1710
SFT NW 286 w/Key	2975
SFT/286 LVL1 w/Key Card	1899
All Others	Call

LANGUAGES

Basic Compiler (Microsoft)	\$167
C Compiler (Microsoft)	254
Cobol Compiler (Microsoft)	508
Fortran Compiler (Microsoft) 4.0	254
Lattice C Compiler	209
Macro Assembler (Microsoft)	84
Pascal Compiler (Microsoft)	170
Quick Basic 4.0	57
Quick C	57
Ryan McFarlan Fortran	379
Ryan McFarlan Cobol	609
Turbo Basic	58
Turbo C	58
Turbo Pascal 4.0	58
Turbo Prolog	89
Turbo Prolog Toolbox	89

TRAINING

Chuck Yeager Adv. Flight Simulator	\$25
Lets C	38
Mavis Beacon Typing	29
MS Learning DOS	29
MS Flight Simulator	29
PC Logo	79
Turbo Tutor 4.0	42
Typing Instructor Encore	20
Typing Tutor IV	27

SPREADSHEETS

Cambridge Analyst	\$79
4 Word	55
HAL	89
Lotus 1-2-3 Ver. 2.01	295
Lotus Manuscript	309
Lotus Report Writer	67
MS Excel	280
Multiplan 4.0 (Microsoft)	110
PFS Professional Plan	52
Quattro	140
Supercalc 4	278
Twin Classic	32
VP Planner	47
VP Planner Plus	112



MEMBER
MMC
MICROCOMPUTER
MARKETING COUNCIL
of the
Direct Marketing Association Inc.

- No Charge for VISA and Mastercard
- We Do Not Charge Your Card Until Your Order is Shipped
- You Pay the Ground Shipping \$6.00 (except Alaska and Hawaii) We Pay the Air Difference
- Free Air applies ONLY to orders up to 10 lbs. & Over \$50.
- Add 5% for C.O.D. Orders

- All products carry only manufacturer's warranties. We do not honor guarantees, rebates, trial period privileges or promotional programs offered by manufacturers.
- No APO, FPO, or international orders, please.
- Call before submitting P.O.'s Ask for National Accounts
- Personal and Company Checks Will Delay Shipping 3 weeks
- Prices, Terms & Availability Subject to Change Without Notice



telemart

ORDER LINE

1-800-426-6659

DOING BUSINESS SINCE 1980
A DIVISION OF CW MARKETING

HARDWARE



PRINTERS

Alps	
Allegro	\$345
ALQ224E	599
ALQ318	610
ALQ324E	749
2418	885
2424	955
Other Models	Call
AST	
Turbo Lazer	4310
Citizen Printers	
120D	149
180D	165
MSP 40	315
MSP 45	465
MSP 50	399
MSP 55	525
Premier 35	505
Tribute 124	Call
Diconix	
150	309
300	485
Epson Printers	Call
Hewlett-Packard	
Desk Jet	719
Lazer Jet Series II	1805
Paint Jet	1090
NEC	
P2200	335
P5200	520
P5300	685
Other Models	Call
Okidata	
320	330
390	465
Lazerline 6	1325
Panasonic	
1080 I M2	159
1091 I M2	180
3131	305
3151	475
Lazer 4450	1635
Star Micronics	Call
Toshiba	
321 SL	489
341 SL	709
351 SX	999
Page Lazer	2415

DISK DRIVES

Bernoulli Box	
10 Meg	\$889
20 Meg	1255
40 Meg	1559
Beta Ext 20 Meg	1015
Beta Int 20 Meg	775
Seagate	
20 MG w/WD Controller	275
251-1 40 Meg AT	469
AT 40 MEG 251	375
Other Models	Call
Teac	
1.2 MEG AT	89
Floppy F55 BV	79
Toshiba	
3.5 Dr 720K	85
3.5 Dr 1.4MG	105

HARD CARDS

Plus 20 MG	\$515
Plus 40 MG	650

KEYBOARDS

Keytronics	
KB5151	\$119
KB5153	149
KB101 +	85

MONITORS

Amdek	
410	\$130
432	149
V210A	80
NEC	
Multisync II	\$595
Multisync Plus	899
Multisync XL	2065
Monographic System	1289
Other Models	Call
Princeton	
Ultrasync	485
Samsung	Call
Sony	
Multiscan (1303)	545
Mitsubishi	
Diamond Scan	499
Zenith	
1490	609

BOARDS

AST	
Hot Shot	\$359
Six Pack Plus	115
Xformer	579
3G + II	219
Other Models	Call
ATI	
EGA Wonder	220
VIP	260
Hercules	
Color Card	145
Graphics Card Plus	170
Incolor	199
Intel	
Inboard 386 PC	935
Inboard 386 w/cable	1025
4020 Aboveboard	325
80287-6	155
80287-16	439
Orchid	
Designer VGA	299
Tiny Turbo	249
Twin Turbo	385
VGA	220
Paradise	
Autoswitch 350	159
VGA +	259
VGA Professional	Call
Video-7	
Fastwrite VGA	355
VGA	269
Vega Deluxe	180
V-RAM	475
NOVELL	
Altec Passive Hub	\$29
AQUILA 8 Port Active Hub	279
AQUILA Arcnet Card	99
SMC 110 Arcnet	129
All Others	Call

TERMINALS

Wyse	
30	\$285
50	369
85	439

COMPUTERS

AST	
Model 80	\$1440
Model 140	2685
Model 340	3999
Model 390	5409
Other Models	Call
NEC	
Multispeed EL II	1469
Toshiba	
T-1000	785
T-1200F	1565
T-1200FB	1699
T-1200H	2285
T-1200HB	2415
T-3200	3785
T-5100	4899
Zenith	
Supersport/2	1655
Supersport 20 MG	2479
Supersport 286/Model 2	3445

MODEMS

Hayes	
1200	\$275
1200B	245
2400B	389
Prometheus	
1200B w/Software	70
2400B w/Software	125
Other Models	Call
US Robotics	
Password 1200	175
Courier 2400	289
Courier 2400E	335
HST 9600	635

- To Place an Order: 1-800-528-1054
- To Follow Up on an Order: (602) 944-2552
- Order Line Hours: Monday-Friday 7:00 a.m.-6:00 p.m.
- Saturday 9:00 a.m.-1:00 p.m.
- Order Processing (602) 944-1037
- 10:00 a.m.-3:00 p.m. Mon.-Fri.
- We Do Not Guarantee Machine Compatibility

Mailing Address:
8804 N. 23rd Avenue / Phoenix, Arizona 85021

telemart

ORDER LINE

1-800-528-1054



Actual unretouched CRT display - 800x600x256

With us you see it ... with them you don't!

Yes folks, nothing up our sleeves! The 1st (and only) Hi-Res VGA Paint package in history is now shipping, hot and heavy! ColoRIX - VGA Paint from RIX SoftWorks to be exact. All the others run only the 320x200-256 color mode (ho hum!) we thought you'd like more. ColoRIX runs in 6 more "ZGA" 256 color resolutions including: 640x350, 640x400, 640x480, 720x540 and 800x600! You only counted five right? Well, we saved the biggest news for last.

Attention PS/2 owners: (Models 50 & up): ColoRIX - VGA Paint runs at 360x480x256 on your computers WITH NO HARDWARE MODIFICATIONS! This mode is exclusive with ColoRIX - VGA Paint.

There are some new tools to go along with ColoRIX like: An automatic 256 palette adjust feature to make working with 256 colors a breeze, an auto-color graduation tool, IMG & PCX (16-level grayscale) support for desktop publishing & ClickArt™ files, TARGA™ file support for more serious graphics folks, Global Contrast-Color & Brightness controls, animation for your presentations, a screen capture program that grabs just about any graphics screen, a screen file translator that converts from one mode to all the rest, Full B&W and color printer support, dynamic zoom, and our hallmark - NO ICONS! Oh yeah, almost forgot! 16 color VGA

support (in 1024x768 too!). There's lots more but we're running out of space. Find out the rest when you get yours or see us at COMDEX Booth 197-198 - LVCC. ColoRIX - An adventure in color!

Special Introductory Price

just **\$199.** (+ shipping)

Call Toll Free: InCA-(800) 233-5983 - OutCA-(800) 345-9059

Europe: Beaugrand Burokommunikation - Dieter Beaugrand
Otto-Hahn-Strabe 24, 6056 Heusenstamm, W. Germany
Telefon: 11-49-6-104-63092 FAX: 11-49-6-744-2883

RIX

RIX SoftWorks, Inc.

18552 MacArthur Bl. Ste.375, Irvine, CA 92715 - (714) 476-8266



THE REVENGE OF THE FILE FORMATS

Jerry tackles a complicated file-conversion problem, takes a look at Unix, and handles some unfinished business

It has been one frantic month. Of course, all months at Chaos Manor tend to be that way, but this one was a doozy. Not only was last month's column late, but there was the column for this fall's *IBM Special Edition*. Now this one is due early: which really means tonight, since tomorrow afternoon I catch a train for San Antonio. I'll stay there a week, then go on to New Orleans for the World Science Fiction Convention.

I'm going to San Antonio because that's where Dr. Francis X. Kane lives. Dr. Kane is one of the coauthors of *Strategy of Technology*, a book first published in 1970 and for years adopted as a textbook in the War Colleges and two of the service academies. We've been revising the book off and on for the past several years, and it's time to get it out the door.

The first step was to print a copy of what we have. That, alas, turned out to be more of a problem than I thought.

Conversions

The original *Strategy of Technology* was written on a Selectric typewriter. The manuscript has long since vanished. When we first decided—about 1984—to revise the book, there was no optical character reader capable of scanning the printed text and turning that into a machine-readable manuscript. Nowadays, I'd use Hewlett-Packard's ScanJet and Flagstaff Engineering's Spot trainable OCR program; *Strategy of Technology* was nicely typeset on good paper,

and from my experience with the ScanJet and Spot, there'd be no problem at all. (See my column in the *IBM Special Edition* for a full discussion of Spot.)

Back then, though, I had no choice but to hire someone to type the entire book into CP/M-based WRITE, which was the text editor I used at the time. The result was stored on 8-inch CP/M disks.

Over the past few years, I have revised some of the key chapters of *Strategy of Technology* and included them as nonfiction in my anthology series on the future of conflict, *There Will Be War* (Tor Books). There are seven volumes in that series, and most of them contain revised chapters of *Strategy of Technology*. I do about one *There Will Be War* book a year, and over time the series has been done on a variety of word processors, beginning with WRITE and ending with the one I use at present, Q&A Write.

Worse, Dr. Kane is from the old school: he writes with a pen on lined yellow legal pads. Someone has to type all that, generally a secretary at whatever place he is working for at the time; since he retired from the Air Force as a colonel, he has been at a lot of places, and each one used a different word processor. Longtime readers of this column will recall my efforts to convert some of his text from Wang 8-inch floppy disks to CP/M.

Anyway, when the crunch came this month, I found I had text in a number of different formats. The trick was to get it all into Q&A Write, integrate all the notes and addenda, and print out a clean copy.

Much of the stuff was in WordPerfect 4.1. That presented a problem. Q&A Write doesn't read any flavor of WordPerfect. Borland's Sprint, however, says that it will read WordPerfect 4.2 files and convert them to WordStar. That sounded good, because Q&A Write says it reads WordStar files. As it happens, some of the stuff I needed to convert had been written in WordStar, so the first

thing was to test Q&A Write's ability to read those files.

Voilà. Worked fine. The only hitch is that what WordStar thinks is italic comes out in Q&A Write as underlined. This wasn't a problem, because Q&A Write's search-and-replace system is extremely versatile: if you search for @u1 and tell it to replace with @it, it will convert all the underlined text to italic. I could even use it to correct spelling. I had *glasnost* spelled incorrectly throughout, so I told Q&A Write to search for \@u1 glasnost\ and replace with \@it glasnost\ before I did the global underline-to-italic conversion. That worked fine.

So. If I could get those WordPerfect 4.1 files into WordStar, I'd be all right. First thing was to try Sprint's conversion. No go. Sprint aborted with a mysterious error message. I figured there was no point in looking it up. Clearly, Sprint won't read version 4.1 files. Next thing, then, was to read each file with WordPerfect 4.2, then save the file, thus converting it to a 4.2 file. It was tedious, but it worked.

Now, I figured, I could use Sprint to convert to WordStar.

Not really. Sprint aborted with a mysterious error message: Conversion error 37. Fine. Look in the Sprint manuals—there are two or three of them, each as thick as a book—and see what the error is. The only problem was that nowhere in the several hundred pages of Sprint manuals does Borland tell you what the conversion error messages mean. I tried a couple of other files, with the same result. The one certain thing was that Sprint wasn't going to convert those WordPerfect files into anything at all.

As a last resort, I used WordPerfect 4.2 to read the files, then saved them as ASCII files. That was even more tedious than before, and saving as ASCII wipes out all the italics and boldface and some of the formatting, but it did work. Q&A

continued

Write read those in fine. It has a read-in option called "Special ASCII" that removes carriage returns from the ends of lines (but not paragraphs), so that I now have text that edits with word wrap enabled. I had to go through and put in all the italics—principally book titles—by hand, but even that wasn't onerous given the versatility of Q&A Write's search-and-replace capability.

I continue to be impressed by its search-and-replace function. The one

thing I would add is a "surrounded by" feature—that is, the ability to search for everything framed on both ends by some character like the underbar, a control character, or some combination of those, and replace the formatting characters by another set of surrounds.

As an example, you'd be able to say "search for everything between a Control-B and a Control-D, and italicize it," or "find everything between pairs of Control-B, and replace the first Control-

B with '<it>' and the second Control-B with '<rom>'." That latter would, of course, let you convert files to Atex format.

Anyway, once I had all the WordPerfect and WordStar files read in, it was time to bring in old WRITE files off 8-inch floppy disks. That was simple enough: I fired up the Golem, my trusty CompuPro 8/16. It runs Concurrent DOS, which will copy CP/M files to PC-formatted 5¼-inch floppy disks. It took a minute for me to remember how to use PIP.COM, but after that there was no problem.

Of course, there's a trick to it: WRITE marks the ends of paragraphs with a carriage return but no linefeed; Q&A Write looks for linefeeds but pays no attention to carriage returns. This is a holdover from the old days, when ASCII was devised to control Teletype machines: the linefeed character dropped the print head down a line without moving it horizontally, while the carriage return moved the head to the left side of the page without any vertical motion. ASCII has no "newline" character and has to make do with the carriage return/linefeed pair.

At my insistence, Symantec changed Q&A so that it will recognize either a carriage return or a linefeed as the paragraph marker—but, alas, while that feature was built into Q&A 3.0, it hasn't yet been retrofitted into stand-alone Q&A Write. Thus, I had to use Q&A to read in the WRITE files. That's no great hardship, since Q&A has the Q&A Write editor built into it, so I created a "strategy" subdirectory in Q&A, moved all the files from Q&A Write over to it, and did all the rest of my edits using Q&A 3.0.

Printer Blues

It took working until 6:00 a.m. three nights in a row, but I managed to collect all the notes, additions, and rewrites we'd accumulated over the years and incorporate them into the relevant parts of the book; and this morning I had six chapters complete, as far as I'm concerned. That's more than half the book.

The next thing was to print those chapters and FedEx them off to Dr. Kane so he can be working on them while I'm relaxing on the train. (Actually, I won't be relaxing, I'll be working on fiction. I have a private room on the Limited, and I'm taking the Zenith Z-286 SupersPort laptop. For two whole days the telephones can't ring, and no one will be able to find me. I expect to get a lot done, but that's next month's story.)

I figured that printing the chapters
continued

Who has the
DOS enhancement utility
that supports your VGA?
Your partitioned hard drive?
Your mouse?
Your expanded
memory?
Could be you!



COMDEX
BALLY'S 1341

Get Tree86™*, the fastest, most powerful hard disc manager money can buy, for only \$89.95. See your dealer or call 1-800-548-5019

Tree86. The Power Tool. *Version 2.0*

The Aldridge Company, 2500 CityWest Blvd., Ste. 575, Houston, TX 77042—713/953-1940.

*Supports DOS 2.0 through 4.0

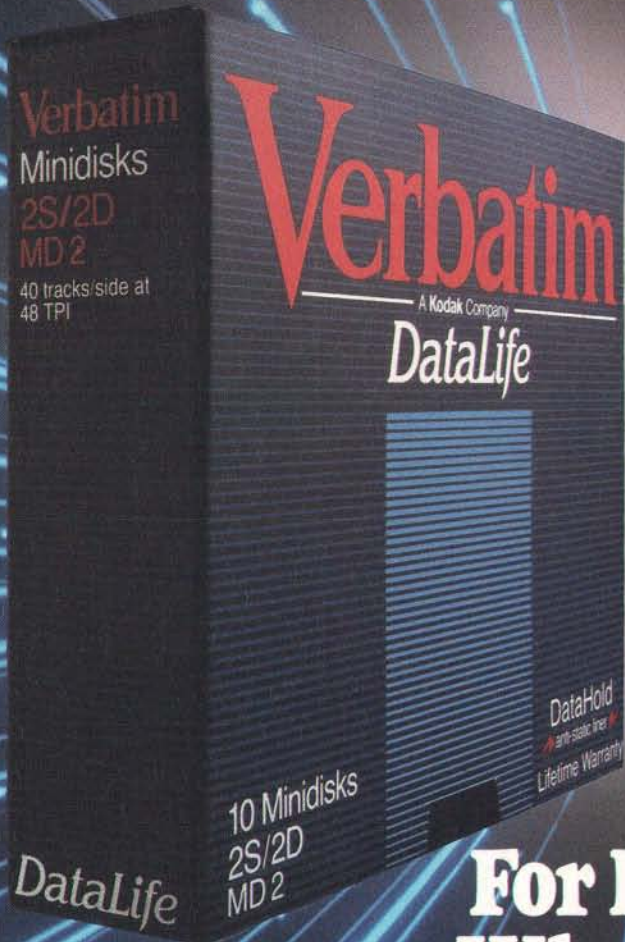

For People Who Put A Premium On Performance. And Protection.

The more invaluable your data is to you, the more you'll value Verbatim® floppy disks. Because when it comes to high performance and data protection, Verbatim has the winning combination no other floppies can copy.

You expect high performance from Verbatim, so it's no wonder that all our DataLife® floppies are engineered to perform an average of 50 million revolutions. That's fifteen times the industry standard.

Setting new standards in data protection is another Verbatim advantage. After all, nearly 50% of all computer users have experienced data loss. Which directly translates into lost time, productivity and money. That's why Verbatim offers advantages like DataHold™ and DataHold II anti-static liners. So static charges are dispersed before they ever have a chance to build up.



For the world's ultimate data protection, DataLifePlus™ floppies have an exclusive DuPont Teflon® coating. So fingerprints, coffee, soft drinks, and even greasy foods can be easily wiped from the recording surface. To virtually eliminate data loss.

What's more, Verbatim DataLifePlus and DataLife HD 5¼" floppy disks are preformatted. Another Verbatim advantage. And of course, all Verbatim floppy disks are tested to be 100% error free and are backed by a lifetime warranty.

Verbatim data cassettes and cartridges, 8", 5¼" and 3½" diskettes. The only clear choice for people who put a premium on performance and protection.

For more information on the full line of high quality Verbatim products, call 1-800-538-8589.

® Teflon is a DuPont registered trademark.



DOING MORE FOR THE DATA PROCESS™

would be straightforward. After all, I've been printing books with Q&A Write for some time now; Q&A 3.0 is a later version, and therefore should be even less trouble.

The best printer I have is the Kyocera F-3010 laser printer. I've described this jewel before. It's fast, it's reliable, and it emulates darned near any other printer in the world. The only trouble with it is that it's somewhat bigger than the printer stand. I'm getting new furniture, but

until I do, my main printer is still the Hewlett-Packard LaserJet Plus. The Plus is not quite so fancy as the LaserJet II, being an upgraded LaserJet I with more memory and smarts.

Alas, when I told Q&A 3.0 to print my files, the results were all cockeyed. Q&A 3.0 wasn't properly initializing the printer; at least, I think that was the problem. The symptoms were that the header didn't appear at the top of any page but the first one; after that, it ap-

peared to progressively move down several lines per page.

I checked the printer installation. Q&A 3.0 offered me a choice of drivers for a LaserJet I or a LaserJet II. No Plus. I selected the LaserJet I. I could, I suppose, have fooled around with Q&A and tried to make it work—I could even manually send the complicated escape sequences that initialize the LaserJet—but that seemed pointless, and besides it was getting late—and I was getting frantic.

I hadn't done all that work just to miss the FedEx deadline because the printer had developed a Critical Need Detector error! I knew I could print those files with Q&A Write, because I've been using that for months. Nothing for it, then, but to transfer all the files back from Q&A 3.0 to Q&A Write. While I was at it, I wrote everything off onto the Maximum Storage WORM (write once, read many times) drive for backup.

There was one more problem. While Q&A Write has a kind of batch file that will let you print a whole slew of chapters (you list what you want to print in one master file), there is no global "double-space" command. Each file (there are six—one for each chapter) needs to be brought into Q&A Write, told to be printed double-spaced, and saved without printing. This doesn't take all that long, but it is tedious. I've complained to Symantec, and they claim they'll fix the problem in the next release. I hope so.

Anyway, I called in each file, revised the header, declared that I wanted double-spaced text, and saved the file; after which everything worked like a charm. Q&A Write squirted the text over to the ACT Printer Optimizer (a box of memory that serves as the printer buffer); the Optimizer fed the LaserJet Plus; and paper came spewing out at about 6 pages a minute, half as fast as I could get with the Kyocera F-3010, but still fast enough.

Of course, there was one final problem. Unlike the Kyocera printer (and other printers that use the Kyocera engine), the LaserJet spits out paper face-up. That stacks it in precisely the wrong order from the way you want it. A year or so ago, I bought a gadget called the Collaser, which is a thingummy that dangles below the LaserJet's output slot. The paper falls into the Collaser, which is shaped in a way that causes it to stack itself face-down.

At least, that's what it's supposed to do. What actually happens is that about one sheet in 10 won't quite clear the LaserJet's output slot. It lacks only about

continued

California FREEMWARE

ONLY \$2.99 per disk! ONLY \$2.99 per disk! ONLY \$2.99 per disk!

Public Domain and Shareware for IBM™ and Compatibles, DOS™ 2.1 or higher. Programs and Utilities to meet all your computing needs.

BUSINESS

- **EE-FORMS** Rev. D15 (80) - Menu driven, msc. forms.
- **EASY PROJECT V3.5** (440) - Complete project management system. Excellent.
- **REAL ESTATE ANALYST (83)** - Menu driven, mortgages, interest, etc.
- **IN CONTROL (174 & 176)** - (2 disk set) The ultimate prospect/client/customer tracking system. Hard drive req. Great.
- **BUSINESS LETTERS (303 & 304)** - (2 disk set) 850 business letters to fit all your needs. Edit w/ any word processor.
- **LEGAL LETTERS (811)** - 100 legal letters to fit all your needs. Edit w/ any wp.
- **MR. BILL V3.3 (811 & 313)** - (2 disk set) Time & billing package; costs, credits, reports, audit trail, etc.
- **LANDLORD V3.01 (885)** - Fast & friendly rental property mgmt. Hard drive.
- **FINANCE MANAGER V4.0 (77)** - Accounting package for business or personal finances. Double entry system.
- **PRO FC-ACCOUNT SYSTEM (828)** - Fully integrated G/L, A/R, A/P system. Menu driven, on-screen help, & much more.
- **CATALYST (183 & 184)** - (2 disk set) The ultimate mailing list manager.

COMMUNICATIONS

- **COMMOS V3.1 (853 & 854)** - (2 disk set) Full featured modem program. 200 number dialing directory, etc.
- **PROCOMM PLUS TEST DRIVE V1.1 (804)** - Menu driven modem program; will test one of the best.
- **BOYAN (488)** - Modem program. Great reviews from all. Great newswriter.

DATABASE

- **FILE EXPRESS V4.3 (33 & 34)** - (2 disk set) Menu driven, easy to use database for beginners to experienced.
- **PC-FILE & V3.0 (465 - 468)** - (3 disk set) Full-featured database; help screens, menus, macros. One of the best. (J Button)

EDUCATION

- **COMPOSER (3)** - Create, save, edit, play, & print your music.
- **LETTERFALL V1.1 (118)** - Improve your touch typing skills; 10 levels.
- **THE WORLD 3D (137)** - Display maps of the world. CGA required.
- **FURNELLE & BUCKETS V2.0 (130)** - Great learning game; add, subtract, multiply, & divide. Ages 5 - 10.
- **MATH-WHITE (188)** - Teaches various math operations. Ages 5 and up. You choose the level. Basic required.
- **ALGEBRA TUTOR V1.01 (577)** - By Peor Wisconsin, teaches operations of algebra, tracks score.
- **ANIMAL MATH/MORPHIC (181)** - Count objects & graphic learning tool. Ages 4 & up - CGA required.

AMES

- **BLUETH V4.1 (86)** - Murder mystery game similar to the board game "CLUE".
- **BLACKLACK (88)** - Advanced blackjack game with cut, multiple players. Best one yvt. CGA or Hercules.
- **MONOPOLY V6.7 (108)** - Just like the board game. 2 to 4 players. CGA req.
- **TREASURE QUEST V1.1 (200)** - Formerly DND. The classic dungeon game.

- **LAS VEGAS (118)** - Craps, Roulette, Poker, & more. CGA req. Bank on some.
- **3D CHESS V1.01 (218)** - Excellent chess game. Switch between 2D & 3D.
- **SUPER PINBALL (213)** - 5 different games. CGA required.
- **WORDPLAY (387)** - Wheel of Fortune clone. You provide the prize. CGA req.
- **MINIATURE GOLF (506)** - 16 hole golf course with graphics. CGA req.

GRAPHICS

- **FINGERPAINT V3.0 (282)** - Paint program; 6 fonts, 81 styles.
- **PRINTMASTER GRAPHICS (318)** - 3 libraries of graphics. Printmaster Plus req.
- **PRINTSHOP GRAPHICS (320)** - 3 libraries of graphics. Printshop req.
- **PC-KEY-DRAW V3.33 (834-836)** - (3 disk set) - Combination CAD & paint program for power & flexibility.
- **DANCAD 3D V3.08 (434 & 435)** - (2 disk set) Advanced 2D/3D drafting program. 640k req.
- **CITY DESK V3.0 (197)** - Simple desktop publisher with graphics capability.

NOVELTY

- **STRESS & SHRINK (74)** - Stress - stress test. Shrink - personality analysis.
- **FASTBUCKS (191)** - Menu-driven home finance package. Easy to use.
- **EDNA'S COOKBOOK (868)** - Recipe database, add your own, print them out.
- **G.I.F.T.S. (818)** - Gift ideas for all occasions. Select by criteria.
- **ASTROL 95 (884)** - Astrology program.
- **HOMEBASE V3.5 (828-830)** - (3 disk set) Great desktop organizer. Calendar, reminder, planner & much more.

PRINTER UTILITIES

- **LQ V3.1 (808)** - Produces high quality text on dot matrix printers. Multiple fonts with print spooler.
- **LABER FONTS/1 (337)** - Over 30 downloadable fonts for LaserJet / II
- **BRADFORD (551)** - Print any file with higher quality in a large variety of fonts.

SPREADSHEET

- **PC CALC & V 1.0 (537-538)** - (3 disk set) - Complete program. Buttondown.
- **LOTUS PROGRAMS (28 - 32)** - (5 disk set) Contains as many applications and utilities that we could find. Lotus 123 req.
- **AS EASY AS V3.0 (303)** - Lotus clone. 52 column sheet, graphing, supports functions of 123, "WKS" files, etc.
- **LOTUS LEARNING SYSTEM (458)** - A tutorial that covers overview, applications, etc. Lotus NOT required.

UTILITIES

- **DISK COMMANDO V2.0 (218 & 318)** - (2 disk set) Norton Advanced Utilities clone. Too many features.
- **8IM-COA (220)** - Great for most programs that need color (CGA) to run.
- **DOS HELP (258)** - Help screen for DOS commands, functions & batch files - at your fingertips. For DOS 3.XX.
- **DOS TUTORIAL V4.3 (256)** - Menu

- driven, learn to use your computer.
- **AUTOMENU V4.01 (280)** - Access programs, batch files, commands, etc.
- **VACCINE (941)** - Various programs to fight against the "VIRUS" & "TROIJAN HORSE" programs. A MUST FOR ALL...

WORD PROCESSING

- **PC-WRITE V3.71 (9 & 10)** - (2 disk set) Full featured word processor; all the features of the expensive one's.
- **GALAXY V3.3 (11)** - Easy to use word processor; menus & quick keyboard commands. Lots of features.

WHAT'S NEW?

- **WORDPERFECT MACROS (189)** - Over 80 macros for Wordperfect V5.0.
- **OH-SIDE (880)** - Slideways printing program.
- **PDS QUOTE V3.14 (873)** - Quickly prepare quotes for any project.
- **CYRUS (891)** - 3D EGA chess game. EGA required.
- **WEIGHT CONTROL (888)** - Programs designed to get rid of unwanted inches.
- **BELPOWER V3.9 (901)** - A timekeeping, billing & bookkeeping program for small firms. Req. 450K & hard drive.
- **EMPLOYEE MGMT SYSTEM (888)** - Program to evaluate best person for job.
- **CUNNING FOOTBALL (893)** - Interactive graphic football game. EGA required.
- **DC-WRITE (897)** - Write to tape of U.S. Federal Government.
- **THE NUTRITIONIST (870 & 871)** - (2 disk set) Evaluate foods for nutritional content.

ORDER FORM

NAME _____
 ADDRESS _____
 CITY _____ ST _____ ZIP _____
 PHONE (____) _____

Multiple disk sets count as the # of disks in a set @ \$2.99 each.
 3.5" media @ \$3.99 ea
 # of 5.25" disks @ \$2.99 = _____
 CA Res. Sales Tax (6.5%) = _____
 Shipping & Handling = 3.00
 Orders shipped UPS ground
 TOTAL = \$ _____
 International orders add \$10.00 for S/H & payment must be in US funds
 Mail order form & payment to:
California FREEMWARE
 1466 Springline Dr. Dept A
 Palmdale, CA 93550
(805) 273-0300
 Hours: M-F 8am - 4pm PST
 Call or write for a free catalog containing over 700 disks of quality software.
 Please orders placed before 12pm PST sent same day.

Yes - We accept VISA/MC Orders. Prices subject to change without notice. Please call for warranty information.

MEMBER THE SOFTWARE ASSOCIATION

VISA

DISC 1188

See you at
COMDEX/Fall '88!
(Booth #1736, Bally's Las Vegas)

THE PROGRAMMER'S SHOP

money, and cut frustrations. Compare, evaluate, and find products.

386 PROGRAMMERS: Special Prices on Solid Tools

	List	Normal	SPECIAL
NDP C-386 by MicroWay	\$595	\$549	\$499
NDP FORTRAN 386 From MicroWay, globally optimizing compilers syntactically and operationally compatible to Berkeley 4.2 Unix F77, PCC, with MS/DOS extensions for easy porting.	\$595	\$549	\$499
FoxBASE PLUS/386 Solid Dbase environment from Fox Software.	\$595	\$419	\$369
VM 386 Multitasker Run unlimited tasks in virtual 8086 mode, by IGC.	\$245	\$229	\$199

Order before November 30, 1988 and mention "BYB88" for these special prices:

386 Development Tools

386 Assembler/Linker	\$ 389
386 Debug - by Phar Lap	\$ 129
386/DOS Extender	\$ 919
DESQview PS/2	\$ 109
F77L-EM - by Lahey	Call
FoxBASE+ /386	\$ 419
High C - by MetaWare	Call
MS Windows/386	\$ 129
OS/286 & 386 by AI Architects	Call
Paradox 386	\$ 649
VM/386 multitasker - by IGC	\$ 229

Basic & Addons

Exim Toolkit	\$ 85
LaserPak Professional - by Crescent	\$ 139
MS QuickBASIC v4.0	\$ 69
QuickPak Professional - by Crescent	\$ 139

C Language-Compilers

AZTEC C86 - Commercial	\$ 499
C86 PLUS - by CI	\$ 359
High C Optimizing Compiler	Call
Instant-C/16M	Call
Lattice C - v3.3	\$ 259
Microsoft C 5.1 - with CodeView	\$ 299
Microsoft QuickC	\$ 69
NDP C-386 - by MicroWay	\$ 529
Turbo C - by Borland	\$ 67
Watcom C6.0	\$ 259

C Language-Interpreters

C-terp - by Gimpel, full K & R	\$ 219
C Trainer - by Catalytic	\$ 89
Interactive C - by IMPACC Associates	\$ 189
Run/C	\$ 79
Run/C Professional	\$ 145
Turbo C-terp	\$ 229

DataBase & File Management

Advanced Revelation	\$ 779
CLARION - complete environment	Call
DataFlex by Data Access	\$ 595
Magic PC - visual database	\$ 169
Paradox v2.0	\$ 499
Paradox Network Pack	\$ 719
R:Base for DOS	\$ 549
XDB-SQL Database	\$ 449

Dbase Language

Clipper Summer '87 - multiuser	\$ 419
dBASE III LANPack	\$ 649
dBASE III Plus	\$ 399
DBXL Interpreter - by Word Tech	\$ 99
FoxBASE+v2.0	\$ 259
McMax - by Nantucket	\$ 235
Quicksilver Diamond	\$ 369

Dbase Tools

dbc III - by Lattice	\$ 169
dBRIEF with BRIEF	Call
Documentor - dFlow superset	\$ 229
Genifer - by Bytel, code generator	\$ 249
Integrated Development Library	\$ 129
Networker Plus	\$ 229
QuickCode III Plus	\$ 189
R&R Report Writer	\$ 139
Seek-It - Query-by-example	\$ 79
Silver Comm Library	\$ 139
Tom Rettig's Library	\$ 79
UI Programmer - user interfaces	\$ 249

RECENT DISCOVERY

Turbo Assembler/Debugger - Assembler compatible with 4.0, 5.0, 5.1 MASM, more complete error checking, 386 support, interfaces to Turbo Pascal and C. Debugger has overlapping views, EMS support, 386 virtual machine, follow pointers through linked lists, CodeView - compatible executables. \$ 109

File Addons

Btrieve ISAM	\$ 189
SQL - SQL for Btrieve	\$ 619
C Development Toolkit - by Migent	\$ 419
c-tree by Faircom - source, no royalties	\$ 319
db_VISTA - network model	Call
WKS Library - read & write WKS & DBF	\$ 179

General Addons

C Tools Plus - v5.0	\$ 99
C Utilities - by Essential	\$ 129
Greenleaf SuperFunctions	\$ 199
!resident_C */ - make TSR's, w/source	\$ 149
Turbo C Tools - by Blaise	\$ 99

Graphic Screens & Windows

dBase Graphics for C	\$ 69
Drawbridge - Metawindows, MQC or TBC	\$ 115
ESSENTIAL GRAPHICS - no royalties	\$ 235
with source	\$ 519
Flash Up	\$ 69
Flash Up Toolbox	\$ 39
GraphIC - like DISSPLA, source	\$ 309
GSS Graphics Dev't Toolkit	\$ 399
Halo '88 - 140+ devices	\$ 229
Hi-Screen XL	\$ 129
Hoops 3D Graphics Library	\$ 549
MetaWINDOWS/PLUS	\$ 219
QuickWindows/C	\$ 99

Other Languages

Alslys Ada - w/maintenance	\$3765
APL Plus - by STSC	\$ 549
CCSM Mumps - single user	\$ 149
CCSM Mumps - multiuser	\$ 469
Modula-2 Dev. System - by Logitech	\$ 219
RPG II - complete, by Lattice	\$1269
SNOBOL4+ - great for strings	\$ 85

Other Products

Carbon Copy	\$ 159
CO/SESSION - remote access & control	\$ 209
Single version	\$ 115
Support License	\$ 159
Crosstalk XVI	\$ 129
MathCad	\$ 289
Mirror II - Crosstalk clone (+)	\$ 59
SPSS/PC Plus	\$ 749
TK Solver Plus	\$ 339
Ventura Publisher	\$ 795
Watchdog - multi-level security for DOS	\$ 265
Word Perfect	\$ 299
Zap-VT100. Xmodem, Kermit	\$ 89

Dbase Generator

SYCERO db - Extensible Clipper/FoxBASE generator allows you to incorporate your code into SYCERO. Up to 30 databases, 14 indexes, 10 levels of submenus and overlaying of 26 programs. Network version available. \$449
SYCERO db NET, \$649

Note: All prices subject to change without notice. Mention this ad. Some prices are specials. Ask about COD and PDs. Formats: 3" laptop now available, plus 200 others. UPS surface shipping add \$3 per normal item.

BRIEF™ Users: Now you can have fast compilation AND an integrated, productive environment.

Introducing
BRIEF v2.1

Over 5,000 of you were forced to make sacrifices to use BRIEF, The Programmer's Editor. Advanced compilers and new programming environments, like Turbo C and QuickBASIC, took up so much RAM that BRIEF could not fit in the same 640k.

If you wanted to retain BRIEF's uniquely powerful features¹ while working with larger programs, you had to sacrifice speed and continuity. Instead of a tight Edit-Compile-Edit loop, you had to slog through an obsolete Edit-Exit-Compile-Exit-Edit loop.

Now you no longer have to make that sacrifice.

You can enjoy the features¹ that have made BRIEF the best-selling and the best regarded² programmer's editor without sacrificing environment integration.

Version 2.1 of BRIEF can be swapped in and out with a single keystroke — allowing immediate compilation with even the largest compilers: Microsoft C5.0, QuickC, Turbo C, Lattice C, dBXL, FoxBASE+ v2.0, Clipper, etc.

¹ For example: real multi-level Undo (not simply Undelete), flexible windowing, unlimited file size, unlimited number of simultaneous files, automatic language sensitive indentation.

² For example: "The quintessential programmer's editor." — *Dr. Dobbs' Journal* "Right out of the box, it's a versatile, extremely powerful editor that handles most any programming task with aplomb." — *Computer Language* "Simple to learn and use and extremely sophisticated. Strongly recommended." — *PC Magazine* "Not only the best programmer's text editor I've ever seen, but it is also a *tour de force* in the way it was conceived and implemented." — *Computerworld* "So far surpasses users' expectations that it is revolutionary." — *MicroTimes Magazine* "BRIEF is truly outstanding." — *Microsoft Systems Journal*

Current BRIEF Users:

Call Ann for details on 4 other important enhancements. Registered users of versions 2.0 or 2.01 update for only \$35.

Haven't tried BRIEF yet?

BRIEF retails for \$195. Call Ann today for a no-risk, 60-day trial with a full, money-back guarantee.

Call toll-free today
800-821-2492



541 Main Street, Suite 410
South Weymouth, MA 02190
617-337-6963

THE PROGRAMMER'S SHOP

Your complete source for software, services, and answers
5-B Pond Park Road, Hingham, MA 02043
Mass: 800-442-8070 or 617-740-2510 9/88

Call for a catalog, literature, and solid value

800-421-8006



Diamond Scan 14
Auto-Tracking
800 x 600 pixels (digital, analog, monochrome)
330 x 500 pixels (composite NTSC)

Diamond Scan 20A
Auto-Tracking
800 x 600 pixels (digital, analog, monochrome)
1024 x 800 pixels (maximum)

Diamond Scan 16L
Auto-Tracking
1024 x 768 pixels (typical)
1280 x 1024 pixels (maximum)

Diamond Scan 20L
Auto-Tracking
Up to 1280 x 1024 pixels

Actual unretouched screen images

A Clear View To Monitor Quality

CHAOS MANOR

$\frac{1}{8}$ inch, but that's enough; the printer thinks there's a paper jam. Clearing the paper jams is simple enough, because the LaserJet, like all laser printers I'm aware of, remembers what it was doing when the jam happened and reprints the page that was spoiled; but it's still more work than I like.

However, I noticed that if you lead the paper out another $\frac{1}{4}$ inch, it falls into the Collaser just fine. All it takes is something attached to the lip of the LaserJet's output slot. After some thought, I hit upon duct-taping a long bamboo Chinese back scratcher to the LaserJet Plus. It looks silly, but it works just fine.

So, I got my six chapters—about 200 pages—printed in time for the FedEx pickup, and all's well.

When I get back from my trip, though, I'm going to hurry the installation of the Kyocera F-3010. It's not that I don't like my LaserJet Plus, but it does look a bit odd with that back scratcher taped to it.

Unfinished Business

I did get a lot done on *Strategy of Technology*, but otherwise this month has been something of a bust: everything I started

seems to have just sort of died away.

For example, I was going to do a thorough test of FastTRAP, MicroSpeed's trackball substitute for a mouse. Last month, I tried FastTRAP and found it pretty good for CAD situations, but not very useful for normal mouse actions, where you have to click-and-drag. Then I discovered that I'd neglected a key feature of FastTRAP—namely, that MicroSpeed has built into the hardware a method of simulating a click-and-drag operation.

What happens is that you can set up the three buttons above the FastTRAP trackball so that when you press the middle button, it is as if you have pressed and held the left button. Now, moving the cursor by manipulating the trackball produces the same result as if you did click-and-drag with the left button. This continues until you press either the left or the center button again. You can use this emulation to select text, choose icons, or do anything else you might do with mouse click-and-drag.

Incidentally, I don't apologize for missing this feature. It's well documented, but I had little incentive to read

the FastTRAP documents. Someone at MicroSpeed got fascinated with fonts and desktop publishing packages, and, not content with having named their product FastTRAP, they proceeded to put most of the text in a thin, light sans-serif typeface, while the word FastTRAP is always set in a larger font and boldfaced wherever it appears in the documentation. It appears quite often, a dozen times on each page. They also played other games with fonts and boldfacing. The result is so incredibly ugly that you'd have to see it to believe it. Certainly, I had no desire to read it.

If you get past the unaesthetic typography, the FastTRAP documents do tell you quite a lot. Also, once you start getting used to it, FastTRAP may very well be easier to use than a mouse.

My original intention was to disconnect the mouse and substitute FastTRAP for a month, after which I'd know which I preferred.

Alas, the test didn't get made this month. Too much work piled up; enough that I just didn't have time to learn FastTRAP—and it does take some learning. I normally use Logitech's Point editor as

Only one supplier of color monitors offers the widest selection of features and operating flexibilities in the market today.

That company is Mitsubishi Electronics.

Mitsubishi® delivers the reliability and performance that can meet your color information display requirements today as well as tomorrow. Larger screen sizes, truer colors, and optimum resolutions make your work easier—and far more productive.

Whether your requirements call for fixed-frequency graphics standards, like EGA and VGA, or multiple-frequency performance, Mitsubishi has the color monitor

with the resolution and size to fit your specific needs. This includes the Diamond Scan Series of 14", 16" and 20" auto-tracking monitors, some with microprocessor-enhanced programmable display settings. All at very competitive prices.

To get a clear view of monitor quality and value, look to Mitsubishi.

For product information or nearest authorized Mitsubishi Electronics sales representatives, please call 1-800-556-1234, ext. 54M. In California, call 1-800-441-2345, ext. 54M. Mitsubishi Electronics America, Inc., Computer Peripherals Division, 991 Knox Street, Torrance, CA 90502, (213) 217-5732.



XC1429C
VGA Compatible
640 x 480 pixels

XC1410C/XC1430C
EGA Compatible
640 x 350 pixels

Mitsubishi Model	Screen Size (Inches)	Horizontal Scan Frequency (kHz)	Mask Pitch (mm)	Compatibility/Resolution						
				NTSC	CGA	EGA	VGA		1024 x 768 (48 kHz)	1280 x 1024 (64 kHz)
							Std.	Ext.		
Diamond Scan 14 (AUM1381A)	14/13V	15.7 - 36 auto-tracking	0.31	*	*	*	*	*	*	*
Diamond Scan 16L* (HL6605TK)	16/15V	30 - 64 auto-tracking	0.31			*	*	*	*	*
Diamond Scan 20A (HA3905ADK)	20/19V	15.7 - 36 auto-tracking	0.31		*	*	*	*	*	*
Diamond Scan 20L* (HL6905TK)	20/19V	30 - 64 auto-tracking	0.31			*	*	*	*	*
XC1429C	14/13V	31.5	0.28			*				
XC1410C	14/13V	22 or 15.75	0.40		*	*				
XC1430C	14/13V	22 or 15.75	0.31		*	*				

*Microprocessor-enhanced programmable display settings



See us at COMDEX Booth #1128

© 1988 Mitsubishi Electronics America, Inc.
Mitsubishi is a registered trademark of Mitsubishi Electric Corp., Tokyo

Screen images produced with permission from the following companies (trademarked software package name follows company name): Autodesk, Inc. (AutoShade); Computervision Corporation (Personal Designer); Computer Friends, Inc. (Modern Artist); SuperMac Software (PixelPaint); Three IDI Graphics, Inc. (Perspective); Microsoft Corporation (Excel Version 2.0).

And Value.

CHAOS MANOR

my general-purpose utility editor. Point not only requires a mouse, it's not really happy unless the mouse has three buttons. There are also a fair number of click-and-drag operations.

While you can, on the fly, reprogram the FastTRAP center button from "sticky" to "same as left and right buttons pressed simultaneously," it's a bit tricky to remember to do that each time you need to change modes. My first couple of attempts to use FastTRAP with Point were near disasters; and while it was clear that I could, eventually, learn to use FastTRAP—and I might even like it—it was also clear that while learning I wasn't going to get a lot of work done. Best to wait until next month. More then.

Internal or External?

Another unfinished bit is the installation of the Supra MegaDrive, an internal hard disk drive for the Atari Mega ST. The installation itself went smoothly. The Mega ST isn't all that easy to take apart—there are too many screws by half—but, if you're at all used to mucking about with a computer, it's no great

task. Supra's directions are sufficiently clear, and besides, it's pretty obvious where everything goes. It didn't take my son Alex an hour to install the drive and get the Mega ST back together.

It works, too. You can boot off the internal hard disk drive, and if there's any difference in speed between the internal and external drives, I don't know it.

Unfortunately, we have not been able to get both drives working at the same time. The Mega ST will recognize either the internal or the external drive and boot off it; but it won't recognize both. Since I have most of my programs stored on the external disk, this can be serious: how do I transfer those programs? One at a time with floppies? That would certainly give me a hobby.

It's probable that we're doing something wrong and there's a way to make the Mega ST see both drives at once, but if so, we can't figure it out.

I also have a Supra 10-megabyte 5 1/4-inch external floppy disk drive. That would certainly facilitate the transfer of programs from one hard disk to the other. Alas, we've been totally unable to make that work. I know it can be done

because I've seen it in operation at shows, but I'm darned if I can do it. With any luck, we'll have all those problems taken care of by next month. Meanwhile, if you have or are getting a Mega ST, you won't have any problems installing and using your Supra MegaDrive, and it does save space.

Unix for PCompatibles

We have now spent two months experimenting with Unix on the Zenith Z-386, with mixed results.

First, it does work. You can, with considerable effort, install any of several brands of Unix—we tried Santa Cruz Operation Unix and Zenith's Xenix—on the Z-386, and they work. Plug several user terminals into the system and you'll have multiuser capability, and you can run all kinds of Unix software. Most of that software tends to be pretty vanilla compared to what's available for DOS—I'm not terribly impressed with any Unix word processor, database, or spreadsheet I've seen—but you'll be able to grep and use all the Unix utilities and system stuff. If you have special needs—multi-

continued

For Anyone Who Considers Code A Four Letter Word.

If you think writing program code is a dirty business, we have something to help you clean up your act.

It's called Matrix Layout. Layout lets you create programs that do exactly what you want, quickly and easily—without writing a single line of code. Layout does it for you automatically, in your choice of Turbo Pascal, Turbo C, Microsoft C, Quick-Basic or Lattice C. And if you're not a programmer, you can even create programs that are ready-to-run.

As the first true CASE (Computer Aided Software Engineering) development tool for the PC, Layout lets you write your programs simply by drawing an icon-based flow chart. They'll have windows, icons, menus, buttons, dialog boxes, and beautiful graphics and text. Like the Macintosh and the OS/2 Presentation Manager.

And because Layout is so efficient, everything you create will work incredibly fast, even on standard PC's with 256K and only one disk drive. To top it off, all your programs will feature Layout's automatic mouse support, sophisticated Hypertext functions, and decision handling.

The full Layout package also

comes with three additional programs:

Matrix Paint is a professional paint program that comes with a full palette of high-powered graphics tools, plus scanner support. And any picture or symbol that you draw or

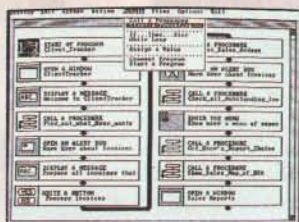

1. Draw a flow-chart.
2. Matrix Layout creates the program code.
3. Your program is complete.



scan into Paint can be included in your program.

Matrix Helpmaker allows you to include an electronic manual in all your programs. Context-sensitive help windows, a table of contents, indexing, and the convenience of Hypertext functionality can now become a part of everything you create.

Finally, Matrix Desktop gives you the ability to organize your files and disks in a very Macintosh-like easy to see, easy to use way.

What's the cost? At just \$149.95 for the entire package, Layout speaks in a language you'll love to hear. Especially with our free customer support, no copy protection, and a 30-day, money-back guarantee.

Video Tape Offer

Our new demonstration videotape graphically illustrates how the many features of Matrix Layout will make a difference in your life. Call 1-800-533-5644 and order your VHS copy now (just \$9.95 for shipping and handling, credited against your purchase). In Massachusetts, call (617) 567-0037.

Do it today. Because once you see what Layout can do for you, we think you'll swear by it.

M A T R I X
L A Y O U T

Circle 208 on Reader Service Card

Matrix Software Technology Corporation • One Massachusetts Technology Center • Harborside Drive • Boston, MA 02128 • (617) 567-0037

Matrix Software/UK • Plymouth, England • 796-363 • Matrix Software/Belgium • Geldenaaksebaan 476 • 3030 Leuven • 016202064

The following are registered and unregistered trademarks of the companies listed: Matrix Layout, Matrix Paint, Matrix Helpmaker, Matrix Desktop, Matrix Software Technology Corporation; Macintosh, Apple Computer, Inc.; OS/2 Presentation Manager, International Business Machines Corporation.

Picture Permanent.



Brilliant Color Output With IBM® Compatibility.

If you're looking for an easy-to-use color printer that delivers fast, high quality color output, with full IBM compatibility, look at the G330-70 from Mitsubishi Electronics.

A built-in video interface enables the G330-70 to create a permanent copy on glossy paper or transparency film of any image viewed on your computer monitor.

With 150 dots per inch resolution, the G330-70 is ideally suited for presentation graphics, paint-type graphic art and PC CAD. It operates smoothly in several PC environments, including the IBM PC/XT/AT and compatibles, IBM PS/2™ or the Apple® Macintosh™ II. The G330-70 can print the screen displays from popular graphics boards, including CGA, EGA, VGA and Mac II.

For fast, bold, brilliant color output directly from your monitor, specify the Mitsubishi® G330-70. At a suggested retail price of \$5900, the G330-70 offers the most convenient method for high quality color output.

For product information or nearest authorized Mitsubishi Electronics sales representatives, please call 1-800-556-1234, ext. 54R. In California, call 1-800-441-2345, ext. 54R. Mitsubishi Electronics America, Inc., Computer Peripherals Division, 991 Knox Street, Torrance, CA 90502, (213) 217-5732.

The G330-70 color thermal transfer printer produces a full-color 8½" x 11" page or transparency in about 80 seconds.

See us at COMDEX
Booth #1128



© 1988 Mitsubishi Electronics America, Inc.
Mitsubishi is a registered trademark of Mitsubishi Electric Corp., Tokyo.
IBM is a registered trademark of International Business Machines Corporation.
Apple is a registered trademark of Apple Computer, Inc.

Images printed with permission from the following companies (trademarked software package name follows company name):
Three I D Graphics, Inc. (Perspective), ZSoft Corporation (PC Paintbrush Plus); Autodesk, Inc. (AutoShade).

CHAOS MANOR

user real-time access to a big database is the example that comes instantly to mind—Unix may well be what you need.

Of course, you may also need more than an 80386-based computer can give you. I'm told that the fastest Unix 80386 system is a Cheetah. This is because multiuser systems tend to unduly stress cache software, and with enough users making enough calls, the raw hardware governs. A 25-MHz Cheetah 386 with a Priam 330-megabyte hard disk drive is an awesome thing to behold, but if you hang enough users on it, you can overwhelm that, too. My point is that if you just like Unix, you can certainly get it in an 80386 computer; but if you have business requirements that demand Unix, you'll need better professional advice than I can give you.

Once you have Unix set up, you can install Locus Merge 386, a program that lets you run DOS under Unix. It won't be cheap, and the installation isn't simple. Alex, who studied computer science at the University of California at San Diego, tried three times, and eventually we brought in our friend David Butterfield, who wrote a good part of the Locus pro-

gram. Even he had difficulties, mostly with the hardware configuration. For example, you cannot run Unix with the Zenith Z-448 video board and the ZCM-1490 Flat Technology Monitor. Unix wants a fairly vanilla EGA board if you're to have color in DOS.

However, they did get the Locus program running, and it did run most of my favorite software. We had Q&A, Quattro, Sprint, Expert 87, and some other stuff going. Most of The Norton Utilities worked. Games and graphics programs that write directly to the screen were a pain; some worked, and some didn't. Unix doesn't really like or understand color, or at least that's my conclusion.

The thing is, it did work at least as well as OS/2's compatibility box, except that you can run a number of DOS programs at once.

On the other hand, it was slow. Not painfully slow, but certainly slower than I'm used to with the Z-386. And we couldn't get it to access a CD-ROM.

We also discovered that Unix doesn't really do multitasking. Before anyone gets excited, let me explain. One complaint I have about Q&A is that while I

don't often need multiple windows, I sometimes do, and Q&A doesn't have any. Under DESQview, that's no problem. I just open two Q&A DESQview windows. When I tried that with Unix, even though I was only one user, I got a message saying that I'd have to buy the network version of the program. Unix apparently thinks multitasking is only a special case of multiusing, and it networks those tasks.

My conclusion is that if you want to do it, you certainly can use Unix instead of OS/2, DESQview, or VM/386. If you have good and compelling reasons to do that, it's worth investigating.

I don't have any such reasons, and I needed the Z-386, so last week we reformatted the drive and installed DOS.

DOS 4.0

This is another unfinished project. We got a vanilla IBM DOS 4.0 to work, more or less, on the Z-386; but there are a lot of incompatibilities. As an example, The Norton Utilities don't work. Norton says they already have a patch to take care of that, but I haven't got it yet.

continued

We had glitches with mouse software. I'd hoped that DOS 4.0 would make it simpler to use a CD-ROM, but so far I haven't got a CD-ROM reader to work with it at all. I've had some troubles with the WORM drive, too.

Priam says they think 4.0 will work all right with their 330-megabyte drive, but they're not sure, and in any event they'll have a version of their enhanced-small-device-interface (ESDI) controller software tested with 4.0 by the time you read this column. Other colleagues have told me of odd glitches they've experienced.

Zenith says it will have its own brand of DOS 4.0 Real Soon Now. Meanwhile, IBM is famous for collecting all the problems experienced with a new release of DOS and putting out an update; I suspect that about the time you read this, you'll be able to get DOS 4.01. My advice is to wait for it.

Noise and Modems

Chaos Manor used to be famous for line-noise problems. We didn't know whether it was the internal wiring or our local phone connection; but when I first began

logging onto BIX, I was driven half batty by noise.

All that went away when we installed a USRobotics Courier HST 9600-bit-per-second modem. Indeed, the improvement was so dramatic that I thought the OmniTel 2400-bps internal modem I'd been using had failing chips. Anyway, for months now I've had no line-noise problems, and I've gotten used to reliable communications at 2400 bps (for BIX) and up to 9600 bps to bulletin boards.

Then, suddenly, my Courier HST began to do odd things. It would turn on the phones, or the little red lights would flash—when I wasn't even using the modem. I'd get strange noises from the speaker. It would dump me out of communications, sometimes locking up the machine so I had to reset. All the problems would be cured if I turned the modem off and back on, but then they'd come back again.

It didn't take a lot of that to be intolerable. Clearly, something had to be done. The simplest thing would have been to go get Roberta's Courier HST and install that; but I've had a SupraModem 2400 sitting here unopened for some time, and

this seemed a good opportunity to test it.

The SupraModem 2400 is smaller than the Courier HST. There are no set-up switches; the only control is an on/off switch. There are, of course, the usual flashing lights.

The manual is well organized and explains everything, but in fact I didn't have to use it. I didn't do anything but unplug the Courier HST's power supply—the SupraModem 2400 uses different voltages than the Courier HST—and connect the SupraModem 2400 where the Courier HST had been. Then I logged onto BIX without making any adjustments in software. Everything worked, in that I certainly was able to connect to Tymnet and thence to BIX.

The problem was that my line noise was back, in spades, with big casino. I even had trouble logging onto BIX; I kept getting line noise in my password, so I had to try three times. Once on BIX, I was able to read most messages, but there were frequent bursts of garble. Then I tried to upload something with XMODEM. I'd get started, but before the whole file could be transmitted, the

continued

FIVE GOOD REASONS TO BUY A MOUSE-TRAK.™



Count them. With MOUSE-TRAK, five fingers do all the work. Because it uses trackball technology, input and precision control is at your fingertips, not your elbow.

With CAD, Desktop Publishing or Spreadsheet applications, MOUSE-TRAK is easier, faster, more relaxed and a lot more comfortable to use than ordinary input devices.

MOUSE-TRAK OFFERS YOU OPTIONS

2 or 3 buttons — speed control — Multiple Interfacing

MOUSE-TRAK is stationary. Only the highly efficient trackball moves, eliminating tiresome arm and wrist movement. You can operate MOUSE-TRAK in your hand, even sit back with it on your knee. It plugs into your computer and needs no additional power supply.

User definable input keys are in easier-to-use locations. The uniquely patented shape has

been developed through rigorous ergonomic studies of hand sizes and finger geometry. Made in the U.S.,
MOUSE-TRAK



is already in use by the military in planes, subs and tanks. Engineers at IBM™, Texas Instruments™ and Motorola™ are also using MOUSE-TRAKS.

MOUSE-TRAK carries a money back guarantee. If you don't like using MOUSE-TRAK within 30 days, we'll refund your money. And, if you do like it, we'll give you \$10 for your old mouse. MOUSE-TRAK ranges in price from \$139-\$189.

Call us toll-free for the complete story on MOUSE-TRAK and the name of a dealer near you. Our new brochure is available upon request.

1-800-533-4822
(in Texas 214-494-3073)

mouse-trak®

3121 Benton Street, Garland, Texas 75042 USA, Telefax 214-494-4159

IBM, Texas Instruments and Motorola are registered trademarks of their respective companies. MOUSE-TRAK is a registered trademark of ITAC Systems, Inc.

FAST MASTER™ III

XT Turbo Professional Model

56 Reasons why this is *THE* system you should buy!

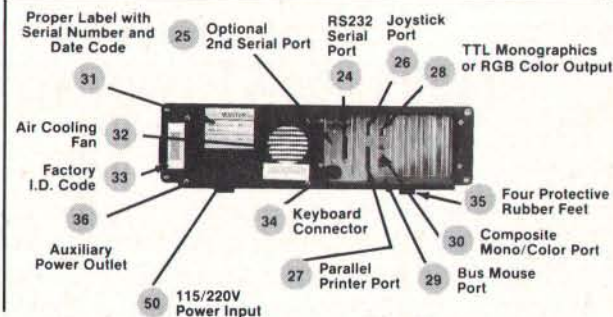
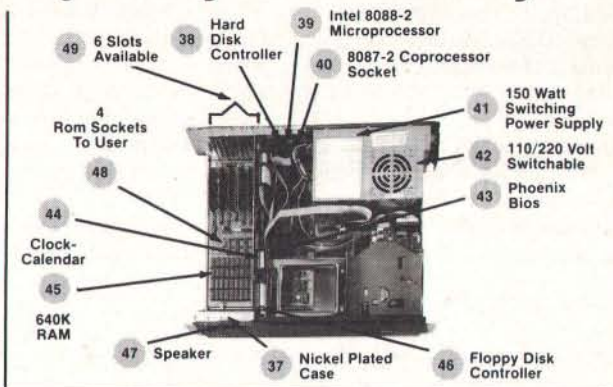
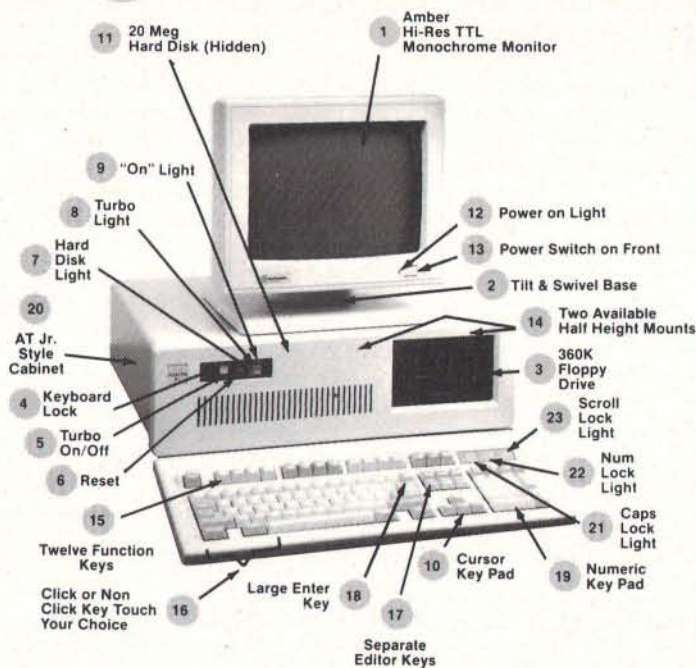

- 51 Standard or AT Jr. Case
- 52 30-Day Money-Back Guarantee
- 53 2 Year Limited Parts/Labor Warranty
- 54 48 Hour Burn-In Testing
- 55 FREE Utility Software

56 All This for only **\$997⁰⁰**

Speeds 4.77 to 25 Mhz

About CORTEX Corporation

When you're looking for Personal Computers, peripherals, accessories, or supplies at the best price available "PLUS" the priceless support you just can't get from the warehouse stores... CORTEX is the place.

When you are tired of being "sold" something, we invite you to a refreshing break. Contact us today. Our experienced staff is dedicated to consistency, courtesy, and reliability. Our philosophy is to provide you with the product or service that not only fits your budget, but also your requirements. We feel you should get what you're looking for without paying for unnecessary extras.

You must have VALUE. You deserve to be helped by a professional organization instead of a professional salesperson. Our staff is made up of computer professionals, engineers, and technicians who absolutely MUST help you get the most for your dollar.

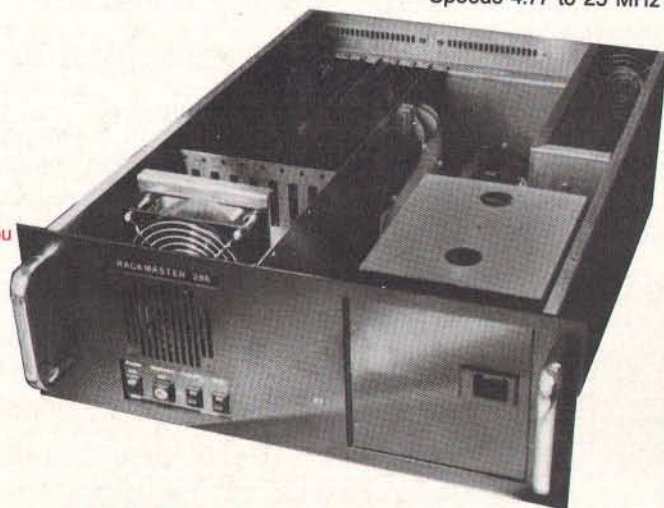

Corporate P.O.s
Government Agencies
Universities

WELCOME

CORTEX CORPORATION

1-800-458-1740

Tech Support 1-612-888-8693

9401 James Ave. S., Bloomington, MN 55431

operation would abort. This happened three times.

I tried everything. I hung up and dialed again; that sometimes cures noisy connections. Not this time. I waited for a while before trying once more. Same thing. I won't say the noise was worse than I'd had with the OmniTel modem, but it sure wasn't any better.

Nothing for it then, I thought. I went down and grabbed Roberta's Courier HST and brought it up. I plugged it in.

Lights flashed in crazy patterns. The speaker made funny noises.

Of course, you've guessed what happened. When I swapped my Courier HST for Roberta's, I didn't bother exchanging power supplies. Why should I? Nothing ever goes wrong with power supplies. Only this time that wasn't true. When I went down and got her power supply, both her and my Courier HST worked fine.

A quick call to USRobotics technical

support got an expression of surprise, and an offer to send a new power supply right away. That came two days later, so now both modems are back in use. While it was coming, Roberta used the SupraModem 2400. She had line-noise problems, too. Perhaps not as bad as I had, but bad enough. When she went back to the Courier HST, the noise went away.

I took the SupraModem 2400 to a different part of the city and connected it to a portable. It worked fine; there was no noise. Back here, though, the noise overwhelms it.

The moral of the story is that if you're lucky enough to have good, quiet, and clean phone connections, you can get away with inexpensive modem equipment; but if you generally have noisy connections, you'll need something a lot better. I don't know what technology USRobotics uses to let the Courier HST deal with line noise, but I do know it works.

Highly recommended.

Internal vs. External

It's always a dilemma. When there's a choice of auxiliary systems, do you get the internal or the external version?

I used to favor internal systems, on the grounds that they don't take up room on the desk and they eliminate the clutter of cables and power cords.

Now, I'm not so sure. First, I had problems with an internal modem. Not only did it take up a slot, but sometimes the only way to reset a modem is to turn it off. Once in a while I like to change phone lines, and if your system sits on the floor in a tower configuration, as mine does, it's a lot easier to reach the back of the modem on the desk than to get down on the floor behind the computer. Finally, it's a lot easier to hear the external modem's speaker. On balance, then, external is probably better for a modem.

Then there's WORM drives. I started with Maximum Storage's APX-3200 external WORM. I really like this, so when I put my big Cheetah development system together, I built in the internal version.

Now, I'm not sure at all.

When you insert a new cartridge into a WORM drive, sometimes the drive latches aren't in the proper place. The result is that the drive rejects the cartridge. The manual says that when that happens, you should turn off the WORM drive, press and hold the eject button, and while holding down the button, turn the drive back on. This will restore the heads and latches to their proper place.

I'm sure I read that, but I forgot it. It's

continued

Write Better Turbo 4.0 Programs... 5.0

Or Your Money Back

You'll write better Turbo Pascal 5.0 programs easier and faster using the powerful analytical tools of Turbo Analyst 5.0. You get an integrated development environment with • Pascal Formatter • Cross Referencer • Program Indexer • Program Lister • Execution Profiler • Includes complete source code. + a new execution timer!

"Turbo Analyst...a valuable tool for every Turbo Pascal programmer. The Program Structure Analyzer... a timesaver. The integrated environment...impressive."

Namir Shammas, Turbo Tech Report, July/Aug. 1988

Turbo Analyst 5.0 is only \$99.

Now with data entry screens!

A Library of Essential Routines

Turbo Professional 5.0 is a library of more than 500 state-of-the-art routines optimized for Turbo Pascal 5.0. It includes complete source code, comprehensive documentation, and powerful and useful demo programs. You get • TSR management • Menu, window, and data entry routines • BCD • Large arrays and more.

"Turbo Professional...a superbly crafted toolbox... [makes] the hard stuff so easy."

Kent Porter, Dr. Dobb's Journal, April 1988

Turbo Professional 5.0 is only \$125.

Call toll free for credit card orders.

1-800-538-8157 ext. 830 (1-800-672-3470 ext 830 in CA)

For upgrade or other information, call 408-438-8608.

Satisfaction guaranteed or your money back within 30 days. Turbo Pascal 4.0 or 5.0 is required. Shipping & taxes prepaid in U.S. & Canada. Elsewhere add \$15 per unit.



TurboPower Software
P.O. Box 66747
Scotts Valley, CA 95066-0747



Wow!

STOP

and Compare Our Quality and Prices Our Standards Are Their Options

IEEE 12 MHz 286

EGA Color System \$1850

- Samsung 14" EGA Color Monitor • 12 MHz PC-AT Computer • Baby AT Case with Key Lock, Turbo, Power and Hard Drive LEDs • Everex Enhanced Auto Switch EGA Card 640 x 480 • Intel 80286 CPU • Multi-speed 6/8/10/12 MHz • Keytronics 101 Enhanced Keyboard • 640k Memory Expandable to 1 Meg • 200 Watt Power Supply • Seagate Model ST251 42+ Meg Hard Disk Drive • 5 1/4" 1.2 Meg Floppy Drive • Western Digital 2 Hard Disk and 2 Floppy Controller with Cables • Serial / Parallel & Game Port • Complete Operations Manual • 80287 Math Co-Processor Slot • One Year Warranty



**286 16 MHz 0 Wait State
Running at 21.0 MHz**

With EGA Multisync (Analog) **\$1950**

With Monochrome + 40 Meg (ST-251) **\$1450**

With Monochrome + 20 Meg (ST-225) **\$1350**

IEEE 20 MHz 386 EGA Color System

\$2995

- Samsung 14" EGA Color Monitor • 20 MHz 0 Wait State Computer • Everex Enhanced Auto Switch EGA Card 640 x 480 • AT Case with Key Lock, Turbo, Power and Hard Drive LEDs (Tower Case available, see below) • Intel 386-20 CPU (not a 386-16) • Keytronics 101 Enhanced Keyboard • 1 Meg Memory • 220 Watt Power Supply • Seagate Model ST251 42+ Meg Hard Disk Drive • 5 1/4" 1.2 Meg Floppy Drive • Western Digital 2 Hard Disk and 2 Floppy Controller with Cables • Serial / Parallel & Game Ports • Math Co-Processor Slot • Complete Operations Manual • One Year Warranty

386-20 MHz EGA Tower Case 40 Meg (ST-251) **\$3195**

386-20 MHz EGA Multisync (Analog) 40 Meg (ST-251) **\$3295**

386-20 MHz EGA Tower Case 80 Meg (ST-4096 28 ms) **\$3495**

386-20 MHz EGA Multisync Tower Case (Analog) 80 Meg (ST-4096 28 ms) **\$3595**

All Systems Also Available with VGA

IEEE 16 MHz 286

EGA Color System \$2250

- Running at 21 MHz • 0 Wait State
- Samsung 14" EGA Color Monitor
- 16 MHz PC-AT Computer • Baby AT Case with Key Lock, Turbo, Power and Hard Drive LEDs • Everex Enhanced Auto Switch EGA Card 640 x 480
- Intel 80286 CPU • Multi-speed 8/16 MHz • Landmark Test of 21 MHz
- Keytronics 101 Enhanced Keyboard
- 1 Meg Memory Expandable to 8 Meg on the Motherboard • 200 Watt Power Supply • Seagate Model ST251 42+ Meg Hard Disk Drive • 5 1/4" 1.2 Meg Floppy Drive • Western Digital 2 Hard Disk and 2 Floppy Controller with Cables
- Serial / Parallel & Game Port • Complete Operations Manual • 80287 Math Co-Processor Slot • One Year Warranty

With EGA Multisync (Analog) **\$2350**

With Monochrome + 40 Meg (ST-251) **\$1850**

With Monochrome + 20 Meg (ST-225) **\$1750**



DOS 3.3 - \$79
DOS 4.0 - \$109

To Order, Call:

1-214-931-3777

ieee, inc. 17120 Dallas Parkway • Suite 212 • Dallas, Texas 75248

TERMS: One Year Warranty (12 months parts / 12 months labor). 30 day money-back guarantee (excluding shipping charge). We accept Visa, MasterCard, Discover (add 3% for credit cards), cashier's check, money order, wire transfer and personal checks (personal checks, please allow 10 working days to clear). Shipping and insurance extra. Prices and availability subject to change without notice. IEEE reserves the right to substitute equivalent or better products. No COD's accepted. 15% restocking fee on unauthorized returns. IBM XT/AT are trademarks of IBM Corporation. HOURS: (Central Time) 9 a.m. to 7 p.m. Monday through Friday, 9 a.m. to 5 p.m. Saturday. MEMBER DALLAS CHAMBER OF COMMERCE

BEST BUYS ON THE MARKET!

80286-12 ZERO WAIT STATE MHz

20 COMPLETE MB EGA SYSTEM... \$1595.

- 80286-12 (12/6) CPU
- 512K (EXPANDABLE TO 1 MEG), 80 NS
- 1.2MB FDD
- 20MB HDD (ST-225)
- W.D. CONTROLLER (2 FDD, 2 HDD)
- EGA CARD w/AUTO SWITCH
- 14" EGA COLOR MONITOR w/TILT & SWIVEL BASE
- SERIAL, PARALLEL PORT
- CLOCK CALENDAR w/BATTERY BACKUP
- TURBO SPEED & RESET BUTTON
- 200W POWER SUPPLY
- 101 ENHANCED KEYBOARD
- 6-16 BIT, 2-8 BIT SLOTS
- 80287 MATH SOCKET
- OS/2 COMPATIBLE

CHOICE OF CABINET
★ FULL (21"L x 16.5"W x 6"H)
★ COMPACT (14.5"W x 16"L x 7"H)

12 MHz ZWS SYS	20 MB ST-225 (65MS)	40 MB ST-251 (40MS)	40 MB ST-251-1(28MS)	80 MB ST-4096 (28MS)
EGA SYS	\$1595.	\$1760.	\$1860.	\$2050.
VGA SYS w/MULTISCAN MONITOR	\$1860.	\$1995.	\$2095.	\$2285.

* 30 DAY MONEY BACK GUARANTEE. Your complete satisfaction is our top priority. Any Suntronics system may be returned within 30 days from the date of shipment for refund less shipping charge. Items returned must be as-new without modification or damage. All manuals and packaging must be included. Return shipping must be prepaid and insured bearing a RMA (Return Material Authorization) on the shipping label.

TURBO-XT \$895. MONO SYSTEM w/20MB HDD

- 8088-2 8 MHz CPU w/640K RAM
- 20MB HDD w/CONTROLLER
- 360KB FLOPPY DISK DRIVE
- MONO G CARD (720 x 348 RES)
- 12" TTL AMBER MONITOR
- SERIAL, PARALLEL, CLOCK CALENDAR
- 101 ENHANCED KEYBOARD
- FRONT RESET SWITCH
- POWER, TURBO LED

80386 \$2785. COMPUTER SYSTEM w/40MB HDD

- 32 BIT 80386-16 (20 MHz OPTION)
- 1 MEG RAM (80NS)
- 40MB HDD
- 1.2MB FDD
- 200W POWER SUPPLY w/DESKTOP CASE
- MONO G CARD w/14" TTL FLAT MONITOR
- SERIAL, PARALLEL, CLOCK CALENDAR
- 32KB (4-8 SRAMs) CACHE MEMORY
- 1-32 BIT (MEMORY), 5-16 BIT & 2-8 BIT SLOTS
- RELOCATABLE EGA & BIOS TO RAM



CALL FOR OTHER CONFIGURATIONS!

SUNTRONICS, INC.

Since 1976

VISA/MASTERCARD ACCEPTED

1-800-545-9777

1 YEAR WARRANTY - PARTS & LABOR
ALL ITEMS IN STOCK!

Prices subject to change without notice - COD requires cash.

MAIN OFFICE (213) 644-1140

12603 S. CRENSHAW BLVD.
HAWTHORNE, CA 90250 M-F 8:30-5:30

ORANGE COUNTY (714) 538-0929

108 W. KATELLA AVE.
ORANGE, CA 92667 M-F 10-6 SAT 10-5

CHAOS MANOR

my practice to back up new work onto a WORM cartridge. I have several of them, one of which is the master backup. That isn't normally in the machine. I keep it in a desk drawer, and periodically I swap it for one that's kept in a safe-deposit box. A few days ago, I had an assistant make the swap. When I inserted the new cartridge into the drive, it wouldn't latch. The cartridge ejected. I pushed in again, and out it came again. I did this several times, and the final time I used too much force. The cartridge went in and stayed all right, but the drive made horrible mechanical grinding noises.

At this point, I had to turn off the power to my machine. It's the only way to turn off the power on an internal WORM. Alas, when I turned the machine back on, the grinding noise started again.

The upshot was that I removed the internal WORM to examine it. I couldn't see anything wrong, but clearly it wasn't working properly. I said a little prayer and used forceps to pull the cartridge out. Then I connected the external drive—Maximum Storage's controller

has both internal and external connectors, so I didn't have to change controller cards—and turned things on, this time holding down the eject button when the machine powered up. Then I inserted the

The
*Maximum Storage
WORM can be accessed
through LANtastic.*

cartridge I'd retrieved.

It all worked fine. Nothing wrong with the cartridge. Probably what's wrong with the internal drive is something very simple. It's beyond me, though, so I've sent it back to Maximum Storage. Meanwhile, the external drive works fine.

However, the incident got me to thinking, and now I'm inclined to prefer the

external drive anyway. I can get several controllers, install them in different machines, and carry the external drive—it's about the size of a shoebox—from one machine to another when it's backup time. For that matter, though, the Maximum Storage WORM can be accessed through LANtastic, and probably any other PC network.

The main thing is that if you have an external drive, it's no trouble to follow the recommended procedures for repositioning the latches and heads. With an internal drive, you have to turn off machine power. I've suggested to Maximum Storage that they might want to put a power switch on the face of the internal unit, and they're considering that.

I still say that anyone who's serious about the value of work done on a computer is insane not to get a WORM drive.

Minor Glitch

Recently, I backed up my entire Priam 330-megabyte drive to a WORM. Of course, the Priam drive wasn't full, but I did have files in drives C through I inclusive. What I did was insert a fresh car-

continued

In a Battle Helmet, No One Can Hear You Scream.

You can hear footsteps running on steel. Shouts in a strange language. Echoes.

Where are they you wonder. What is this Battle Station?

Casey clicks off the safety on her Hyper-Uzi. It thrums to life. Tension.

You flip down your helmet. The world goes suddenly quiet. Your temples scream. The radar in your helmet flashes with color. "Here they come..."



You Started as Raw Recruits. Five eager faces who thought Interstellar Patrol was cake. You learned fast.



Then, Disaster. A dispute between colonists. A mysterious vision. Bloody clues pointed to the sky.



Surrounded in Hyperspace. Friendlies in Yellow, Targets in Red. Electronic fireblossoms.

**No On-Disk Copy Protection.
16 Colors for EGA.**

Sentinel Worlds I: Future Magic

Science Fiction Mystery
Role Playing Game
Designed by Karl Buiter

Circle 119 on Reader Service Card

To Order: VISIT YOUR RETAILER, or call 800-245-4525 from US or Canada, 8am-5pm PST for VISA/MC orders, or mail check (US\$) or VISA/MC #, cardholder name, and exp. date to: Electronic Arts Direct Sales, P.O. Box 7530, San Mateo, CA 94403. Tandy/TBM versions: \$49.95 for 5 1/4"; \$54.95 for 5 1/4" & 3 1/2" dual-pack. Add \$3 for shipping/handling. CA residents add 6.5% sales tax. Allow 1-3 weeks for delivery. Thanks.



ELECTRONIC ARTS®

Subscription Problems?



We want to help!

If you have a problem with your BYTE subscription, write us with the details. We'll do our best to set it right. But we must have the name, address, and zip of the subscription (new and old address, if it's a change of address). If the problem involves a payment, be sure to include copies of the credit card statement, or front and back of cancelled checks. Include a "business hours" phone number if possible.

BYTE

Subscriber Service
P.O. Box 7643
Teaneck, NJ 07666-9866



Items Discussed

Courier HST\$995	Supra MegaDrive
USRobotics	30-megabyte\$799
8100 McCormick Blvd.	40-megabyte\$995
Skokie, IL 60076	SupraModem 2400\$179.95
(312) 982-5010	Supra Corp.
Inquiry 937.	1133 Commercial Way
Locus Merge 386	Albany, OR 97321
two-user version.....\$795	(503) 967-9075
multiuser version.....\$1595	Inquiry 941.
Locus Computing Corp.	Vopt\$59.95
9800 La Cienega Blvd.	Golden Bow
Inglewood, CA 90301	2870 Fifth Ave., Suite 201
(213) 670-6500	San Diego, CA 92103
Inquiry 938.	(619) 298-9349
PC Pillow\$14.95	(800) 284-3269
Universal Data Manufacturing Co.	Inquiry 942.
120 Interstate North Pkwy. E	Word Exchange\$69.95
Suite 420	Systems Compatibility Corp.
Atlanta, GA 30339	401 North Wabash, Suite 600
(800) 535-3282	Chicago, IL 60611
Inquiry 939.	(312) 329-0700
SpinRite\$59	Inquiry 943.
Gibson Research Corp.	
22991 La Cadena	
Laguna Hills, CA 92653	
(714) 830-2200	
Inquiry 940.	

tridge—fresh on one side, anyway—and create directories named C1 through I1. Then I logged onto C and reset the machine, having first brought in AUTO-EXEC.BAT and CONFIG.SYS files that configure a bare system—no mouse driver, no SideKick or other memory-resident programs, nothing at all but the disk driver.

Then I ordered XCOPY C:*. *N:\ C1 /s /e. This copies everything from the C drive onto the C1 subdirectory of N, which is what my WORM drive happens to be. The /s tells XCOPY to create subdirectories if they don't already exist. The /e tells the program to create empty subdirectories as well.

It's not strictly necessary to reset and create a bare system before you use XCOPY, but it may be wise. There's growing evidence that some memory-resident programs interfere with XCOPY in unpredictable ways. Also, XCOPY reads everything it can into memory before it starts writing; the more memory the system has available, the faster XCOPY operates.

I copied the C partition to the WORM

C1 directory and D to D1 without a hitch; but when I copied the E drive, I got read errors. XCOPY lists each file as it reads it, so it was possible to see which file couldn't be read. Also, XCOPY offers you the choice of retry, ignore, or abort. I hit the R key for retry. That didn't work.

After a few more attempts, I wrote down the name of the file that XCOPY couldn't read and hit the I key for ignore. XCOPY went on down the list for a while, then it happened again. All in all, there were about nine read errors, all fairly close together. One of them was cured by retry. I told the system to ignore the others, first writing down the filenames.

After the E drive was done, I went on to the others. There weren't any more errors. When I was all done, I went back to the E drive and used the DOS COPY command to copy all the files from my list into the appropriate subdirectories. I was able to do this with all but one of them; clearly, COPY is less sensitive to minor disk defects than XCOPY.

continued



COMPUTERS FROM IOWA SURPASS ALL OTHERS!

Gateway 2000 has unsurpassed systems, at incredible prices, backed with our excellent service. As noted by our customers:

"We are very happy that our system is at the top of the stack in both price and performance, but it is your courteous service that is uncontested by the competition."

— Pierce Haviland — Kingston, NY

"Overall, I feel that your product is outstanding and your service has been excellent."

— Eric Shogren — Stonington, CT

We look forward to doing business with you and establishing a long-term business relationship.



12 Mhz 286 EGA

512K 80NS Ram
Expandable to 4 Megs on MB
1.2 Meg 5 1/4" Drive
1.44 Meg 3.5" Drive
40 Meg Hard Drive
1 to 1 Interleave
14" EGA Monitor
EVEREX EGA CARD
1 Parallel / 2 Serial Ports
101 Key Keyboard
MS DOS w/GW Basic

\$1895.00

16 Mhz 286 VGA

1 Meg 70NS Ram
0 Wait State S.I. 17.3
1.2 Meg 5 1/4" Drive
1.44 Meg 3.5" Drive
40 Meg Hard Drive
1 to 1 Interleave
EVEREX VGA Board
Paper White VGA Mon.
1 Parallel / 2 Serial Ports
101 Key Keyboard
MS DOS w/GW Basic

\$2295.00

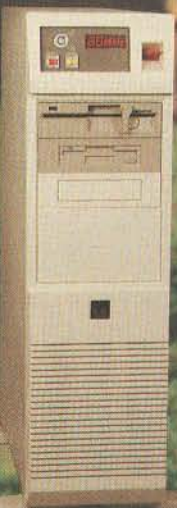

20 Mhz 386 VGA

1 Meg 60NS Ram
1.2 Meg 5 1/4" Drive
1.44 Meg 3.5" Drive
80 Meg Hard Drive
1 to 1 Interleave
EVEREX VGA Board
14" Multisynch Monitor
800 x 600 Resolution
1 Parallel / 2 Serial Ports
101 Key Keyboard
MS DOS w/GW Basic
80287 and 80387 Sockets
Tower Case w/240 Watt P/S

\$3795.00

"When evaluating the whole package, The GATEWAY 386 surpasses all the others!"

Steve Apiki &



Stanford Diehl
BYTE Magazine, Oct.
1988, Review of 20 386 Machines

System Reviewed
20 Mhz 386 Monochrome with 40
Meg Hard Drive

\$2995.00



Gateway 2000 • P.O. Box 2000 • Sgt. Bluff, IA. 51054

800-233-8472 / 712-943-2000

All systems have a 30 day Money Back Guarantee and 1 Year Warranty.
Due to the Volatility in the DRAM Market all prices subject to change.

SpinRite

The one file I hadn't been able to copy wasn't important, so that was all right, but the incident was annoying. I recently got a copy of Steve Gibson's SpinRite. This program supposedly lifts the data off your hard disk a track at a time, re-formats the track, and puts the data back where it found it. SpinRite is said to cure disk problems before they get acute. It's also supposed to significantly speed up your hard disk operations. I've heard very good things about it.

SpinRite is easy, if a bit tedious to use. I first aimed it at the C drive of my ESDI Priam hard disk drive. SpinRite trundled a while and told me there was nothing wrong with the disk. Ditto with D.

At E, it said it found problems. Since I'd just made a backup of the entire hard disk, this seemed a good time to test SpinRite, so I told it to go fix things.

SpinRite trundled for a few moments, told me I had a Priam hard disk drive, and Priam says do not use SpinRite, and I should go read the documents (which, I blush to say, I really had only glanced through). The SpinRite documents say the same thing. Don't use SpinRite with

a Priam drive. That took care of that.

I did try SpinRite on a generic AT clone, and it worked fine—that is, it said it found some soft errors and corrected them. Subsequent tests showed I hadn't

I did try
*SpinRite on a generic
AT clone, and it worked
fine.*

lost any data, and subsequent diagnostics with SpinRite didn't detect any more errors. Beyond that I couldn't say, because I hadn't had any trouble with that system in the first place.

As to the Priam drive, I got out Golden Bow's Vopt program and ran VMARKBAD against the E drive. I've previously recommended Vopt; if you don't have it,

you really ought to get it. Sure enough, VMARKBAD found about nine sectors it didn't like. I told it to mark them so they're not in use any longer.

When IBM brings out DOS 4.01 and Priam certifies it as safe, I'll probably reformat the Priam drive and start over. The WORM backup files will make that simple enough. Until then, when you have 330 megabytes to play with, what's a few kilobytes of bad sectors, anyway?

One More Conversion

Steve Stirling and I are working on a science fiction novella that takes place in Larry Niven's Man/Kzinn Wars sequence. A few minutes ago, I got a disk from Steve with a new outline and a partial draft.

Naturally, it was in WordPerfect.

I could have read it into WordPerfect and written it out as ASCII, but I'd just done that; and I remembered a program called Word Exchange.

Word Exchange works fine. There is a hitch: it translates only to or from Microsoft Word, meaning that to get a WordStar file, I had first to translate Steve's

continued

LOOK!
It's Flow Charting™ II+!

The ultimate fast track tool—for internal auditors, public auditors, secretaries, engineers, managers and line leads. Performance power WITH A PLUS, for even faster and easier construction, editing and printing of flowcharts and org charts.

- Text auto centering
- Smart line mode
- Internal mouse driver
- 10 text fonts
- Ega support
- Comprehensive, friendly manual

Give your charts the PLUS for only \$229*. Contact your local software dealer—or call us.

PATTON & PATTON
Software Corporation

81 Great Oaks Blvd., San Jose, CA 95119
1-800-525-0082, Outside California
408-629-5376, California/International
*plus shipping. In California add tax.

Excellence in charting the flow of ideas

Pick your printer problem and we'll show you a solution.

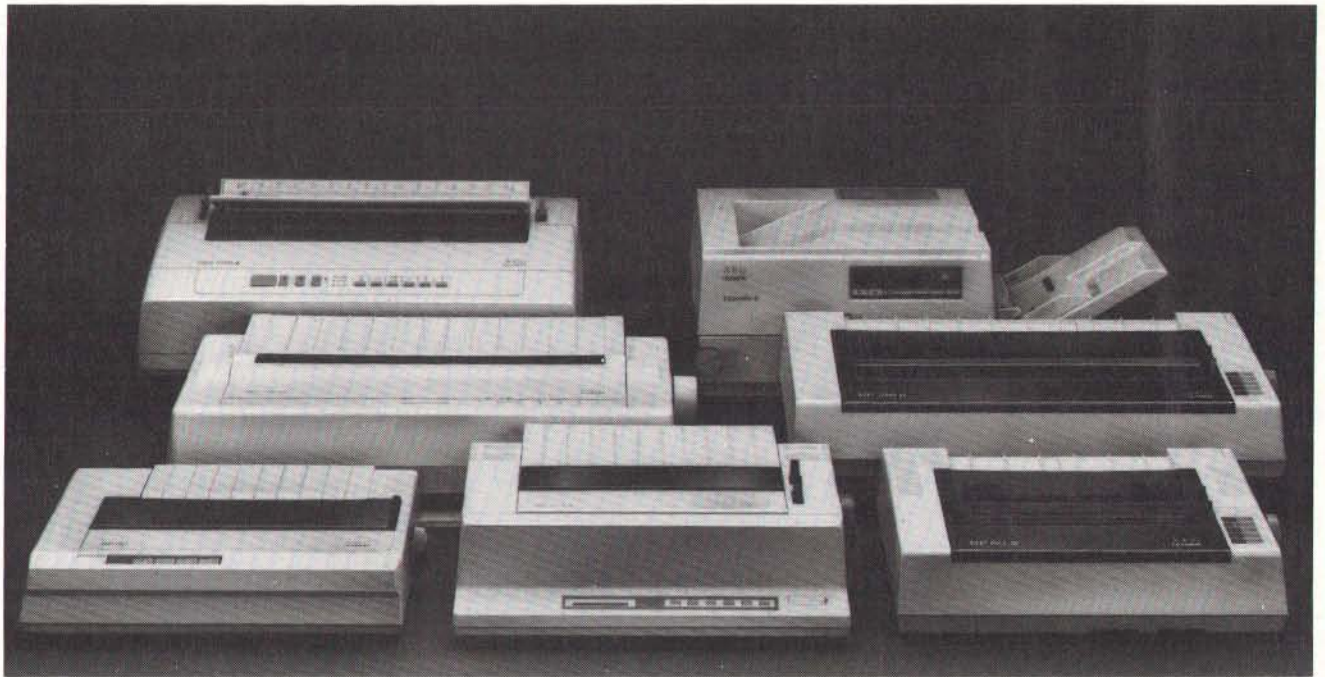

Check off your biggest frustrations with your printer, and we'll tell you about a state-of-the-art remedy from AEG Olympia.

Poor quality print:

Never send out a shoddy or unreadable document again. Let us show you what first class printing looks like on everything from a daisywheel to our Laserstar 6.

Too slow:

How does 240 cps on a 24-pin dot matrix sound to you? Or a laser printer that goes almost twice as fast?

Hard to operate:

We have 8 different models with simplified front-panel controls. Easy to learn. Easy to run.

Clumsy paper handling:

Too hard to switch between fanfold and single-sheet feed? How about a machine with Paper Parking that you don't have to switch at all?

Limited compatibility:

Our printers can make just about any PC look good, from IBMs to Apples, and they'll run on all popular software programs.

Too noisy:

Shut your eyes, and you can't tell whether our Laserstar 6 is on or not.

Not enough fonts:

We have 24-pin dot matrix models with 4 resident fonts, our Laserstar 6 has 9, and for each you can get additional plug-in font cards.

Too expensive:

If you want price/value, look at our best selling dot matrix model NP 30.

No support:

Part of our "product" is our nationwide dealer network. If you have questions about any AEG Olympia printer, the answers are only a phone call away.

Tear out this page

and mail it with your name and address to AEG Olympia, Dept. ADV, Box 22, Somerville, NJ 08876-0022. Or if you're in a hurry, call us at 1-800-999-6872. It's the first step to making your problems go away.

Name _____ Title _____

Telephone _____

Company _____

Address _____

City _____ State _____ Zip _____

984

AEG
OLYMPIA

file to Microsoft Word format, then from that to WordStar. Even on a fast 80386 computer this takes time; but it does work, and his file is now saved in Q&A Write. One fair warning: it takes Q&A Write a lot longer than you expect to read in and translate WordStar files created this way. Don't give up and reset just because nothing seems to be happening.

Word Exchange comes with a 50-page document, but you won't need to read it unless your job is pretty complex.

Mostly, the document lists program limitations. The program reads and writes ASCII, all flavors of DisplayWrite, several versions of WordPerfect, Wang PC, Samna Word, WordStar, and Volkswriter. I haven't tested them all, but it sure seems to work better than Sprint did. It's painless, too.

Winding Down

I'm out of space, but there's still an enormous stack of stuff here. There's PC Pil-

low: a keyboard-size cloth-covered board with padding under it. You put it on your lap and the PC keyboard (or even your whole laptop PC) on top of it, making things both more secure (because it's less likely to slide off) and more comfortable. I'm taking it with me on the train.

There's a new version of DESQview, as well as new DESQview interface tools complete with a debugger. Combine DESQview with the Phar Lap DOS extensions, and you can have multitasking unbound by the 640K-byte limit, while running all your old DOS programs as well. This is a serious competitor to OS/2, and I'll have more on it next month.

There's a whole slew of stuff for the Mac II, including both a facsimile board and a scanner; maybe I'll have a fax at last.

There's Symantec's GrandView, a worthy successor to Ready! and Think-Tank; GrandView is extremely powerful and easy to use; put it in a DESQview window, and you won't know how you ever got along without it.

The book of the month is Robert Wright's *Three Scientists and Their Gods* (Times Books, 1988). The title is a bit of a misnomer; the book is an account of the beliefs and work of Ed Fredkin, F. O. Wilson, and Ken Boulding. Boulding, a Quaker, is the only one close to being a traditionalist. I've known him for some years, and Wright does a pretty good job of presenting his views. The computer book of the month is by Michael Banks, *The Modem Reference* (Brady, 1988). This will tell you all you need to know to get started and keep going in computer communications.

The game of the month is Earl Weaver's *Baseball for the PC*. My baseball fanatic son has spent half the time he isn't actually watching baseball playing the game. Me, I'm still addicted to Empire. The PC version is all right, if a bit slow; it's better on the Atari ST. Of course, if you have an Atari ST and you haven't got *Dungeon Master* out of your system, nothing else counts. ■

Jerry Pournelle holds a doctorate in psychology and is a science fiction writer who also earns a comfortable living writing about computers present and future. Jerry welcomes readers' comments and opinions. Send a self-addressed, stamped envelope to Jerry Pournelle, c/o BYTE, One Phoenix Mill Lane, Peterborough, NH 03458. Please put your address on the letter as well as on the envelope. Due to the high volume of letters, Jerry cannot guarantee a personal reply. You can also contact him on BIX as "jerryrr."

IDEAS TRANSLATE



LIKE YOU IMAGINE

TYPESET & MANUALS,
books FORMULAS & TABLES

in the same **FORMAT** or **differEnt** ONES.....

BIG or **SMALL** **WIDE** or **NARROW** **LIGHT** or **HEAVY** **BOLD** IT'S NICE TO KNOW **PC TEX** WON'T **YOUR** LIMIT **IMAGINATION.**

WITH



To order or for information, call:
415/388-8853
or write: Personal TEX, Inc.
12 Madrona Avenue
Mill Valley, CA 94941 USA

PCTEX is a registered TM of Personal TEX, Inc.
TEX is an American Mathematical Society TM.
Manufacturers' product names are their TMs.

Great ideas should look great on paper. The translation is easy with PCTEX®: the full implementation of Prof. D. Knuth's revolutionary TEX formatting/typesetting program. It offers PC users the capabilities & advantages of professional typesetting.

PCTEX gives you control—of design format, type & symbols, quality—for complex

mathematical & engineering material, statistical tables or straight matter.

So whether you're writing the next starshot manual or the great American novel, depend on PCTEX for camera/publisher-ready manuscripts to be proud of, quick & simple.

From Personal TEX, Inc., starting at \$249; VISA/MC welcome. Satisfaction guaranteed.

PCTEX FORMATTING/TYPESSETTING SYSTEM • FINE TYPESET QUALITY from dot matrix or laser printers, or phototypesetters. • A COMPLETE PRODUCT. Includes • our specially written PCTEX Manual that lets you use TEX immediately • custom 'macro package' formats for letters, manuals, technical documents, etc. • the LaTeX document preparation system (with user's manual) macro package for article, book, report preparation • AMS-TEX, developed by the American Mathematical Society for professional mathematical typesetting. • OUTPUT DEVICE DRIVERS available for Epson FX, LQ • Toshiba • HP LaserJet Series • Apple LaserWriter • Screen preview, with EGA, VGA or Hercules card. • REQUIREMENTS: IBM PC/XT, AT or compatible, DOS 2.0 or higher & 512K RAM; hard disk for printer drivers & fonts.

This ad is typeset & composed using: PCTEX, Bitstream® fonts & laser printer. Logotype & black backgrounds done photographically.

AW...WHAT THE HECK!

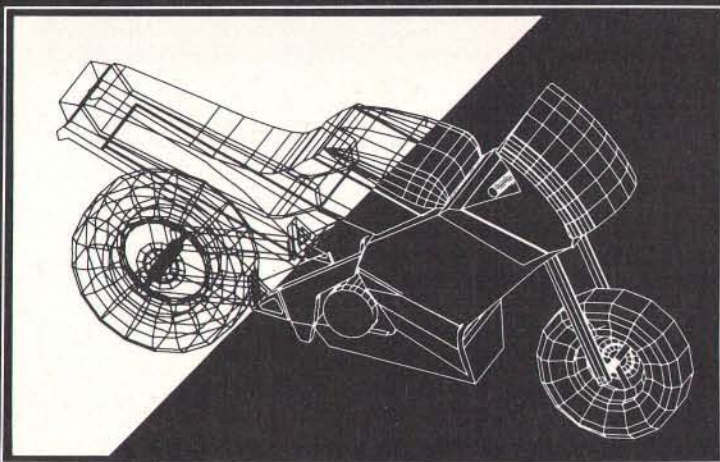

The first question asked by many people is, "Why is *DesignCAD 3-D* priced so low?" The answer? After developing *DesignCAD 3-D* we were unable to decide how the product should be priced. We consulted experts. We used the finest spreadsheets on the market. We took employee polls. We asked our lawyers and accountants for their opinion. We even asked our Mothers, Wives, and childhood Sweethearts! Finally in the greatest American Tradition, we said, "Aw... What the Heck! Let's see the other guys beat this price!" *DesignCAD 3-D* sells for \$299 complete. No add-ons, nothing else to buy!

DesignCAD 3-D is a complete 3-Dimensional CAD system. It offers most, if not all, the features found on programs costing more than \$3000! In fact, **PC Magazine** says, "For a low-cost, self-contained 3-D package *DesignCAD*'s range of features steals the show. The package offers more than adequate features for a wide range of professionals and hobbyists alike."

Once again, American Small Business Computers has proved that you don't have to spend a lot of money to get quality software. *DesignCAD 3-D* provides features such as Shading, Solid Object Modeling, Hidden Line Removal, Cross Sectioning capability, ability to output shaded drawings to laser printers, dot-matrix printers, or pen plotters, extensive file transfer capability, *all for only \$299!* No other 3-Dimensional CAD system can come close to providing the price/performance of *DesignCAD 3-D*.

There is a very important reason to buy *DesignCAD 3-D* other than price: PERFORMANCE! *DesignCAD 3-D* provides complete 3-Dimensional drawing capabilities. It's not a "warmed-over" 2-D program. *DesignCAD 3-D* allows you to draw any entity in 3-D space. This means, for example, that you can draw a curve in the shape of a spring. You can draw a circle or arc at ANY angle on ANY plane.

DesignCAD 3-D allows up to 4 simultaneous views - any angle or perspective - on the screen. *DesignCAD 3-D* also provides complex extrusions—linear, scalar, and circular. Extensive 3-D text capabilities and auto-dimensioning are provided, *at no extra charge, of course!*

DesignCAD 3-D almost certainly is compatible with the computer system you now own. *DesignCAD 3-D* supports more than 200 dot-matrix printers, at high resolution. *DesignCAD 3-D* supports more than 80 plotters, and most digitizers, mice, and graphics adapters available for "PC and PC Compatible" systems. Shaded and wireframe models can be output to the printer or plotter YOU own.

DesignCAD 3-D provides the capability to read drawings from most other CAD systems (*DesignCAD/ProDesign II*, *AutoCAD's DXF*, *Hewlett Packard's HPGL*, and *IGES*). *DesignCAD 3-D* will also write *GE*, and *POSTSCRIPT* files. This file exchange utility is included at no extra charge, of course.

DesignCAD 3-D does not require expensive graphics adapters and monitors - even shading can be done on ordinary displays, such as the Enhanced Graphics Adapter (EGA), Color Graphics Adapter (CGA) and Hercules Monochrome Adapter. *DesignCAD* also supports many of the ultra high resolution graphics adapters, with more hardware being supported daily.

However, the best reason to buy *DesignCAD 3-D* is not the low price. It's not the outstanding performance. It's not the extensive hardware compatibility. *The best reason to buy DesignCAD 3-D is for its amazing ease of use!*

What else do you need to know about *DesignCAD 3-D*? Only this: "Included at No Extra Charge." What is included at no extra charge? **EVERYTHING! \$299 BUYS IT ALL!**

\$299

DesignCAD 3-D

Oh yes, we also market a 2-Dimensional version of *DesignCAD 3-D* with special drafting and design functions. Can they work together? Naturally... Our Mothers, Wives, and childhood Sweethearts would see it no other way! The price?... **\$299, of course!**

How do you get one? See your local computer store or dealer, or contact:

To quote **PC Magazine**...

"DesignCAD 3-D, the latest feature-packed, low-cost CADD package from American Small Business Computers, delivers more bang per buck than any of its low-cost competitors and threatens programs costing ten times as much."

American
Small Business Computers, Inc.

327 So. Mill Street • Pryor, OK 74361
Phone: (918) 825-4844 Fax: 01-918-825-6359
Telex: 9102400302

Write or phone us for FREE DEMO DISK and information on *DesignCAD 3-D* and *DesignCAD 2-D* products.

Circle 26 on Reader Service Card

NOVEMBER 1988 • BYTE 125

Periscope's New Version 4

...Gives you all the right stuff for debugging! No matter which model you pick, you have the same powerful software to help you track down hard-to-find bugs fast.

Periscope's hardware adds the power to solve the really tough debugging problems.

The break-out switch lets you break into the system any time. You can track down a bug instantly, or just check what's going on, without having to reboot or power down and back up. That's really useful when your system hangs! The switch is included with Periscope I, Periscope II, and Periscope III.

Periscope I has a **NEW** board with 512K of write-protected RAM, user-expandable to 1MB, for the Periscope software, symbol tables, and all related debugging information. Normal DOS memory (the lower 640K) is thus totally freed up for your application, and Periscope is protected from being overwritten by a run-away program. The new board's footprint is only 32K, so you can use it in PC, AT, and 386 systems with EGA/VGA and EMS boards installed (not possible with the previous 56K board). It can also be used with Periscope III to provide additional write-protected memory.

Periscope III has a board with 64K of write-protected RAM to store the Periscope software and as much additional information as will fit. AND...

The Periscope III board adds another powerful dimension to your debugging. Its hardware breakpoints and real-time trace buffer let you track down bugs that a software-oriented debugger would take too long to find, or can't find at all!

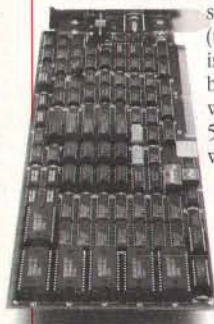

The Periscope III hardware-breakpoint board captures information in real-time, so you'll find bugs that can't be found with a software-based debugger.

Periscope's software is solid, comprehensive, and flexible.

It helps you debug just about any kind of program you can write...thoroughly and efficiently.

Periscope's the answer for debugging device-drivers, memory-resident, non-DOS, and interrupt-driven programs. Periscope works with any language, and provides source and/or symbol support for programs written in high-level languages and assembler.

David Nanian, President of Underware, Inc. (of BRIEF fame) says this about the new Periscope Version 4:

"Periscope has always been an unbelievable assembler-level debugger. Version 4 has turned it into a terrific source-level debugger as well. Aside from major enhancements like the source-level improvements, all the little changes make a really big difference, too. For instance, symbol lookups and disassemblies are noticeably faster, and highlighting the registers that have changed really makes life easier. Once again, Periscope has raised the industry standard for debuggers!"

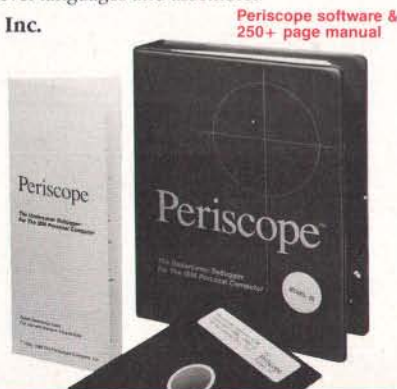

Periscope software & 250+ page manual

What's New in Periscope Version 4:

- View local symbols from Microsoft C (Version 5)
- Debug Microsoft windows applications
- Set breakpoints in PLINK overlays
- Improved source-level support
- Monitor variables in a Watch window
- 80386 debug register support
- Debug using a dumb terminal
- PS/2 watchdog timer support
- Use mixed-case symbols
- Set breakpoints on values of Flags
- Much more!

- **Periscope I** includes a **NEW** full-length board with 512K of write-protected RAM; (user-expandable to 1MB); break-out switch; software and manual for \$695.
- **Periscope II** includes break-out switch; software and manual for \$175.
- **Periscope II-X** includes software and manual (no hardware) for \$145.
- **Periscope III** includes a full-length board with 64K of write-protected RAM, hardware breakpoints and real-time trace buffer; break-out switch; software and manual. Periscope III for machines running up to 10 MHz with one wait-state is \$1395.

Due to the volatility of RAM costs, prices on board models are subject to change without notice.

REQUIREMENTS: IBM PC, XT, AT, PS/2, 80386 or close compatible (Periscope III requires hardware as well as software compatibility, thus will not work on PS/2 or 80386 systems); DOS 2.0 or later; 64K available memory (128K at installation time); one disk drive; an 80-column monitor.

Call us with your questions. We'll be happy to send you free information or help you decide on the model that best fits your needs.

**Order Your Periscope,
Toll-Free, Today!
800-722-7006**

MAJOR CREDIT CARDS ACCEPTED

The
Periscope
Company, Inc.

1197 PEACHTREE ST. • PLAZA LEVEL
ATLANTA, GA 30361 • 404 / 875-8080

PORTABLE SOFTWARE



Programs packed in ROM for traveling computer users; thoughts on Spuds MacKenzie and OS/2

Are you familiar with Spuds MacKenzie? He's that wonderfully ugly bull terrier who acts as the star celebrity in television commercials and print ads for Bud Light beer. The dog has become a major sensation. Billed as "the original party animal," you can find pictures of Spuds on billboards, posters, T-shirts, and even neon signs. But without question, it's the television spots that have rocketed Spuds MacKenzie to superstardom. And television is the medium that really defines the essence of Spuds.

The scenario for each commercial is fairly similar. Spuds is wheeled to center stage wearing a ridiculous costume (a tuxedo or a Hawaiian shirt, for example). A trio of women sings, "Go, Spuds, go!" An announcer extolls the virtues of Bud Light. Dancers whirl about the set, ostensibly portraying the exciting party life. Spuds sits there and pants good-naturedly. That's really all there is to it. Why Spuds MacKenzie should have become a national culture hero is beyond me; perhaps it's because the dog is absolutely expressionless through the course of all this mayhem. Your guess is as good as mine.

Anyway, one evening while watching another 30-second Spuds spot, I suddenly realized that Spuds MacKenzie is a perfect metaphor for OS/2. Think about it for a second. Microsoft wheels OS/2 to center stage, dressed in a tuxedo or a Hawaiian shirt. Singers croon praises. The announcer extolls the virtues of the Presentation Manager, vast amounts of ad-



dressable memory, the DOS compatibility box, and suchlike. Dancers whirl around, symbolizing the computing joy we'll achieve when we switch to the operating system of the future. OS/2 just sits there and pants good-naturedly. Absolutely expressionless.

If you follow the trade press, you'll have noticed that month by month the minimum requirements for a system that can run OS/2 go up as the projections for market share go down. Microsoft has begun muttering that OS/2 will need some sort of dynamite software package to pull the public in, much as VisiCalc lured users to the Apple II way back when.

Though the list of hardware and software companies "endorsing" OS/2 and the Presentation Manager continues to grow, we're still waiting for all that fantastic software we were promised when the show began. None of the OS/2 packages released so far has been the sort of blockbuster that would cause most people to shell out the bucks to make the

switch. And Unix is sitting off in a corner somewhere, sharpening its fangs, waiting to drag OS/2 into a real dogfight.

I propose that while we're waiting for OS/2 to become whatever it is that it's supposed to become, we simply refer to it as OS/Spuds, after Spuds MacKenzie. The phrase rolls off the tongue, and the similarities are hard to miss.

There is one important difference, however. Spuds MacKenzie is doing a good job of selling beer. OS/Spuds isn't selling much of anything yet.

Smallware

I've been messing around with laptops again, after giving up on my Tandy Model 100 a year ago. It had served me well as a portable terminal and a note-taking machine, but my irritation with the teeny screen finally got the better of me. In most other respects, it's a perfect computer; supplemented with Traveling Software's Ultimate ROM II, it can do

continued

Protect Your Copies of BYTE

NOW AVAILABLE:
Custom-designed library files
or binders in elegant blue
simulated leather stamped in
gold leaf.

**Binders—Holds 6
issues, opens flat for
easy reading.**
\$9.95 each, two for
\$18.95, or four for
\$35.95.



Files—Holds 6 issues.
\$7.95 each, two for
\$14.95, or four for
\$27.95.



Order Now!

Mail to: Jesse Jones Industries, Dept. BY,
499 East Erie Ave.,
Philadelphia, PA 19134

Please send _____ files;
_____ binders for BYTE magazine.

Enclosed is \$_____. Add \$1 per
file/binder for postage and handling.
Outside U.S.A. add \$2.50 per file/binder
(U.S. funds only please).

Charge my: (minimum \$15)
_____ American Express _____ Visa
_____ MasterCard _____ Diners Club

Card # _____ Exp. Date _____

Signature _____

CALL TOLL FREE (24 hours):
1-800-972-5858

Name _____

Address _____ (No P.O. Box)

City _____

State _____ Zip _____

Satisfaction guaranteed.
Pennsylvania residents add 6% sales tax.
Allow 5-6 weeks delivery in the U.S.

BYTE

Items Discussed

MemoryMate \$69.95
Broderbund Software
17 Paul Dr.
San Rafael, CA 94903
(415) 492-3200
Inquiry 934.

Tornado \$99.95
Micro Logic Corp.
P.O. Box 70
Hackensack, NJ 07602
(201) 342-6518
Inquiry 935.

Z88 \$549
Cambridge/North America
SSI Computer Systems, Inc.
424 Cumberland Ave.
Portland, ME 04101
(207) 761-3700
Inquiry 936.

many things well, and it weighs almost nothing. But I found myself lugging it around and rarely turning it on, and I'm not enough of a masochist to enjoy carrying dead weight.

Currently, two machines are battling for replacement duties. Note that my needs are relatively simple. I want decent word processing and some way to communicate over telephone lines—nothing more. Forget disk drives, fancy graphics, and MS-DOS. One of the things I enjoy about this approach is that I don't have to use the same software I use on the bigger machines. Yes, I know this is a heretical philosophy and that I should be drooling at Compaqs and Toshibas, but sometimes I find it refreshing to strip down to basics.

One of the contenders is the PC-8500 from NEC, a discontinued model that you can buy only from liquidators. It's a direct descendant of the Kyocera line that includes the Model 100, only this has a 24-line by 80-character screen and some serious software in ROM, including WordStar, a spreadsheet, a filer that allows either standard fields or free-form text, and a telecommunications module. It's also a CP/M machine, which means I can run dozens of little public domain utility programs. It's heavy, though. Six pounds, not including the AC adapter and the essential 128K-byte RAM add-on. And it burns C batteries at an alarm-

ing rate. But WordStar is WordStar, and I've spent some delightful hours with the PC-8500 writing on the back porch.

The competition comes in the form of a bizarre British machine from Clive Sinclair, the Cambridge Computer Z88. To begin with, it's tiny, a hair smaller than a sheet of typing paper and less than an inch thick. It weighs about 2 pounds, and that includes four AA batteries and three ROM or RAM cartridges (I've stocked mine with two 128K-byte RAMs and a ROM that contains a communications program). The display is only 8 lines deep, but it's 106 characters wide and a supertwist liquid crystal display at that. The keyboard is rubber, but the key travel is realistic and the touch is light. Someone with thin fingers like myself can really get some speed going.

On appearance, portability, and ergonomics, the Z88 beats the PC-8500 handily. I haven't decided about the software though, and that's the purpose of throwing this discussion into my column. Both machines are based on the Z80 chip, but the PC-8500 is stocked with old friends from CP/M days, while the software in the Z88 is radically different from anything I've ever seen.

The operating system and a collection of software modules are built into the Z88's ROM. This includes a calculator, clock, alarm, calendar, diary, terminal emulator, printer editor (for saving escape sequences for your output device), file maintenance system, BBC BASIC, and a word processor/spreadsheet combo called PipeDream.

Individual modules are loaded from a main menu and remain active until you explicitly shut them down. I've heard the principle called "lazy concurrency"; although true multitasking is far beyond the capability of this machine, it saves status information in available RAM, letting you jump back and forth among applications quickly. You can even launch multiple "copies" of PipeDream for a simulation of windowing.

PipeDream itself is the major oddity. It's essentially a spreadsheet, with vertical columns labeled with letters and horizontal rows indicated with line numbers. Used as a spreadsheet, its operation is straightforward and not much different from any other spreadsheet. If you know Lotus 1-2-3 or SuperCalc, you can make the adjustment quickly.

However, the spreadsheet paradigm has been modified to allow PipeDream to operate as a fairly decent word processor as well. You can set a right margin for text, and once you begin typing, word

continued

How to create high-performance programs without wasting your time or money

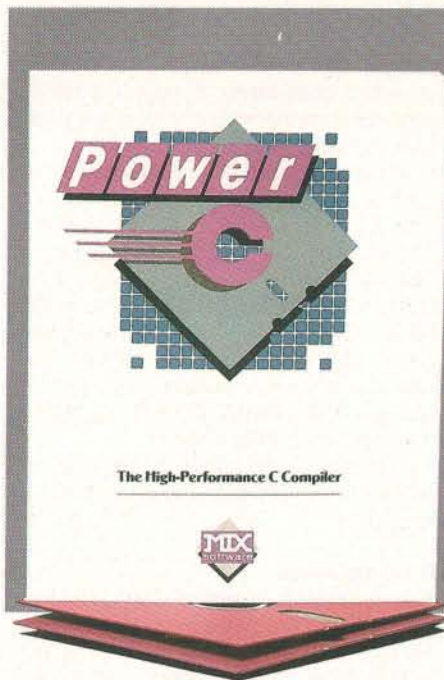

C Source Window

```

46 main [unl] auto unsigned int 2 -ai- 2
30 addr->zip = 76442; size 122
31 printf("The structure memb size > 0
32 printf("%s\n",addr->state);
33 addr->street, addr->ci
34 size = sizeof(struct ADDR
35 printf("The structure size
36 printf("addr->street start
37
38 pr
39 )
40

```

A watchpoint has matured.
size > 0
Old value was 0
New value is 122
Space bar will clear notice & watchpoint

Space for struct starting at address 5416:8000
Assigning values to members.

The structure member values...

```

Joe Bob's Texas
1251 Cow Chip Trail
Fort Worth TX 76442

```

```

addr far ptr 1126201199
addr->name array 0x5416:8000
addr->street array "1251 Cow Chi
addr->city array "Fort Worth"
addr->state array "TX"
addr->zip 76442
size 122
job[0] pointer 0x82c0
*job[0] struct 00x82c0
job[1] pointer 0x82c0

```

Watch Point Window

Output Window

Variables Window

Power Ctrace Debugger

Step 1: The \$19.95 Power C compiler

Power C is the new ANSI compatible C compiler that runs faster than Microsoft C and has more functions than Turbo C®. Power C combines high-performance software with superb documentation, all for less than the price of most C books alone. It's your fast route to fast programs without the fast bucks. Compare Power C to the competition and see how much time and money you'll save.

Performance/Price Chart (execution times in seconds)			
	Power C	Quick C®	Turbo C®
1) fib	23.8	53.4	26.4
2) sieve	27.6	43.2	25.5
3) tdbl	3.5	9.0	9.6
4) diskio	13.5	14.4	14.3
5) report	11.0	71.7	60.7
6) drystone	36.6	41.6	31.8
Compile/Link	73.9	113.5	81.4
EXE File Size	25120	32092	27184
Compiler Price	\$19.95	\$99.00	\$99.95
Debugger Price	\$19.95	N/C	N/A
Library Source	\$10.00	\$150.00	\$150.00
Total Cost	\$49.90	\$249.00	\$249.95

N/C no charge - N/A not available
Benchmarks compiled using Make utility, command-line compiler, and medium memory model

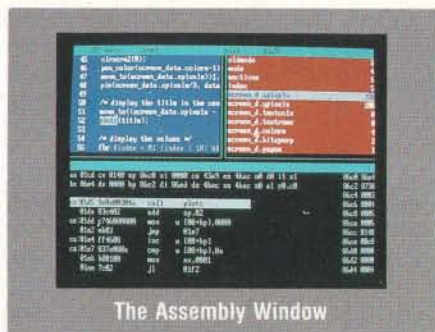

Step 2: The \$19.95 Power Ctrace debugger

Power Ctrace is the new state-of-the-art C debugger that makes Microsoft's Codeview look like old technology. Power Ctrace will reduce the time you spend debugging your C programs by at least a factor of 10. With Power Ctrace, you'll be working smarter instead of harder. Actually, you'll be having so much fun that it won't even feel like work anymore.

Unlike other debuggers, Power Ctrace lets you debug graphics programs on a single monitor. You can even debug programs that write directly to video memory. However, the major advantage of Power Ctrace is simple operation. You won't waste any time trying to understand or remember cryptic commands. With Power Ctrace, a single keystroke is all it takes. Help screens show you which key to press and pop-up menus list your options. Invest just 10 minutes with Power Ctrace now and you'll save hours from now on.



Technical Specifications

Power C includes: Power C compiler with integrated Make, Power C Linker, Power C Libraries (450 functions), the Power C book (680 pages), and support for...

- ANSI standard
- IEEE floating point
- 8087/80287 coprocessor
- auto-sensing of 8087/80287
- automatic register variables
- unlimited program size
- mixed model (near & far pointers)
- graphics on CGA, EGA, VGA, & Hercules

Optional Products:

- Power Ctrace debugger
- Library source code
- BCD business math

Order now by calling our toll free number or mail the coupon to Mix Software, 1132 Commerce Drive, Richardson, TX 75081.

1-800-333-0330

For technical support call: 1-214-783-6001

Minimum System Requirements:
DOS 2.0 or later, 320K memory, 2 floppy drives or hard drive,
Runs on IBM PC, XT, AT, PS/2 and compatibles.

60 day money back guarantee

Name _____
Street _____
City _____
State _____ Zip _____
Telephone _____
Paying by: Money Order Check
 Visa MC AX Discover
Card # _____
Card Expiration Date _____
Computer Name _____ Disk Size _____
 5 1/4" 3 1/2"

Product(s) (Not Copy Protected)

Power C compiler (\$19.95) \$ _____
 Power Ctrace debugger (\$19.95) \$ _____
 Library Source Code (\$10.00) \$ _____
 (includes assembler & library manager)
 BCD Business Math (\$10.00) \$ _____
 Add Shipping (\$5 USA - \$20 Foreign) \$ _____
 Texas Residents add 8% Sales Tax \$ _____
 Total amount of your order \$ _____

Power C & Power Ctrace are trademarks of Mix Software Inc.
Quick C & Codeview are registered trademarks of Microsoft Corp.
Turbo C is a registered trademark of Borland International.

B

PC voice mail, now only \$199.

Watson[®], hailed by one reviewer as "the premier voice mail station" at \$498, is an even better value at \$199. Watson eliminates telephone tag and gives you big-system features like auto speed-dial, auto answer, message forwarding, and built-in 300/1200 bps modem. For an ear-opening business applications demo, call **1 (800) 6-WATSON** (in Mass., (508) 651-2186). To order, call **1 (800) 533-6120** (in Mass., (508) 655-6066). Credit Cards Accepted.



INCLUDES
HAYES[®]
COMPATIBLE
MODEM!

Watson[®]
Natural MicroSystems Corporation

wrap takes you smoothly from line to line. Inserting text into an existing paragraph pushes following text down as needed, but deleting text requires that you issue a "reformat paragraph" command. This is a bit more automated than classic WordStar on the PC-8500, but not as slick as current MS-DOS word processors that handle all reformatting automatically. It's a minor inconvenience, though, and you quickly adjust.

More troubling, however, are traces of spreadsheet functions that have not been altered when you're in text entry mode. Though lines stretch as far as you've set the margin, they're still essentially single spreadsheet cells. The Tab key is useless for paragraph indents, as it moves you from, say, column A to column B, thereby resetting your left margin.

Likewise, you have to use a special "split line" command to insert a carriage return into the middle of an existing line; pressing the Return key merely moves you down to the next line. You can't use the left arrow key to move from the start of one line up to the end of the previous one. And block operations, oriented to cells, take whole lines only; if you want to move a sentence from the middle of one paragraph to the middle of another, you're out of luck.

I find the Z88 extremely frustrating as a result of these niggling inadequacies. Were the software only slightly more polished, it would be amazing. PipeDream lets you mix running text and columns of numbers easily, so there's no need for separate files if you're trying to generate a business report. The word-wrap and standard justification options can be used to create side-by-side narrow columns of text. Mail merge is handled easily by using a spreadsheet as a sort of database. There's even a "word count" command for writers on the go.

What's my reaction to all this? Well, even though the Z88 strikes me as overpriced at \$549 without any additional memory cartridges, 2 pounds is still 2 pounds. If you need a true lightweight laptop, it's the only way to go. The Swiss-Army-knife software covers most of what you'll do on the road, barring any need for powerhouse MS-DOS programs like databases. I took the machine on a week-long trip during which I did a lot of writing, and the software never crashed.

But I do resent the small sacrifices in convenience I have to make to use PipeDream as an editor. I just wish Cambridge would spend a little more time perfecting PipeDream, making it into a more reasonable tool for text handling. And I'd love to see someone else take the

concept and design a spreadsheet with margins and word wrap that can be used on other computers; it makes a lot of sense as a multipurpose tool. It's a great idea, certainly worth investigating.

What about the PC-8500? I suspect I'll keep it around for full-screen editing with WordStar, which still beats PipeDream. The Z88 will become my long-distance machine, accompanying me on trips, while the PC-8500 will live in the house, moving from room to room when I feel like abandoning my office. And with a cable, a null modem, and a gender changer, I can dump files into my bigger machines with little effort.

I refuse to take either laptop with me when I'm on vacation, though. Enough is enough.

Taking Notes

I've repeatedly expressed my affection for an MS-DOS pop-up program called MemoryMate (Broderbund, \$69.95). It's a free-form text database that allows searches on any word; think of it as a stack of 120-line by 80-character cards that can be organized by issuing a search command. You can enter your data in any format you like; field names are not required.

MemoryMate will cut and paste between its records and your main application, so you can use it as a permanent text scrapbook. It's handy for note-taking, and I love the ability to enter random bits of information and retrieve them with a minimum of effort. MemoryMate works the way I do.

Things change quickly in this business, and it's now time to report on the latest batch of enhancements to MemoryMate. Although I had few quibbles with the original, I have to admit that the upgrade provides MemoryMate with several much-needed capabilities. First, the maximum size of MemoryMate's database has gone from 2 to 32 megabytes. Second, you can now switch among named databases, so you can add another level of organization to your record-keeping. Third, you can search for words using a mixture of alphabetic characters and wild-card symbols.

Fourth, MemoryMate now supports the Lotus/Intel/Microsoft Expanded Memory Specification; you have to give up only 30K bytes of main memory. Fifth, author Michael Fremont has added a linking feature, which he calls hyper-text, that lets you chain related records that may not contain the same search words. It's a nice shortcut. Finally, the program is now packaged with a large se-

continued

Order Status,
Technical & Other
Info. (602) 246-2222
FAX # (602) 246-7805

Call for programs not listed

WAREHOUSE DATA PRODUCTS

MICROSOFT PC Excel
SPECIAL \$273
Call on all Microsoft Mouses

TOLL-FREE ORDER LINE 1-800-421-3135

NOW AVAILABLE

MICROSOFT MACH 20 \$309
MICROSOFT WINDOWS 386 \$110

FREE SOFTWARE!

Purchase over \$100 and receive one of these disks absolutely FREE! Purchases over \$250 get two free disks, over \$400 get three, or get all four disks when your purchase is over \$500! 1) MIXED BAG. 2) PC-WRITE. 3) FONT-SET. 4) ABC-LIST.

SOFTWARE

Accounting

Dac Easy Acct. 3.0 **Low Price**
Dac Easy Light \$39
Dac Easy Payroll **Low Price**
Dollars & Sense 94
In House Acct. 112
Managing Your Money 4.0 117

Communication Programs

Brooklyn Bridge Universal \$75
Carbon Copy Plus 108
Crosstalk XVI 89
Crosstalk MK4 110
Flying Dutchman 64
PC Anywhere III 96

Data Base Managers

Clipper \$370
Condor 3 325
DataPerfect **Low Price**
DBase III Plus 375
DB-XL Diamond 115
Fox Base Plus 194
Genifer 189
Paradox 2.0 Premium 435
PFS: Pro File 139
Powerbase 169
Q&A 3.0 **Call**
Quicksilver Diamond 329
Revelation Advanced 485
R Base For DOS 425
Reflex 90
Relate & Report 112
VP Info 65

Desktop Publishing

Pagemaker Ver. 3.0 \$475
PFS: First Publisher 2.0 73
Ventura Publisher 489

Graphics

Boeing Graphics \$200
Chartmaster 199
Design Cad 2D & 3D 148
Diagram Master 199
Easy Cad 109
Generic Cad 49
In-A-Vision 270
Microsoft Chart 3.0 225
Newsroom Pro 65
Printshop 33

Integrated

Ability Plus \$145
Enable 352
Microsoft Works 108
PFS 1st Choice 79
Smart System 380
Symphony 465

Languages

Lattice C Compiler \$220
Microsoft C Compiler Ver. 5.0 **Call**
Microsoft Fortran Ver. 4.1 260
Microsoft Macro Assembler Ver. 5.1 88

Languages

Microsoft Pascal \$176
Microsoft Quick Basic 4.0 59
Microsoft Quick C **Call**
Ryan McFarlan Fortran 390
Ryan McFarlan Cobol 612
Turbo Basic **Call**
Turbo C 1.5 59
Turbo Pascal **Call**
Turbo Prolog 90

Multi-User Software

Fox Base + \$299
Microsoft Word 195
Word Perfect 5.0 339
Word Perfect Modules ea 75

Project Manager

Microsoft Project \$305
Super Project Plus 255
Timeline 3.0 323
Total Harvard Man. 2 355

Spreadsheets

Lotus 1-2-3 \$295
Microsoft PC Excel 273
Quattro 143
Surpass 329
Twin 35
VP Planner Plus 88

Utilities

Core Fast Low Prices
Copy II PC \$19
Copywrite 39
Cubit 39
Desqview 2.01 72
Direct Access 49
Eureka **Call**
Fastback Plus 89
Formtools 56
Graph in the Box 2 **Call**
Mace 55
Microsoft Windows 286 Ver. 2.1 59
Norton Advanced 75
Norton Utilities 48
PC Tools Deluxe 37
Prokey 4.0 70
Q DOS II 49
Righwriter 75
Sidekick Plus 115
Sideways 39
SQZ Plus 55
Superkey 55
Lightening 79
XTree 35

Word Processing

Microsoft Word 4.0 \$185
Multimate Advantage II 285
Q and A Write 110
Webster Spellcheck 37
Word Perfect Ver. 5.0 **Call**
Word Perfect Executive 124
Word Perfect Library 2.0 65
Wordstar Pro 233
Wordstar 2000 + Personal Ed. 229

HARDWARE

Accessories

Copy II PC Deluxe Bd. \$101
Curtis Ruby + 69
Logical Connection 429
Mach III Joystick 36
Masterpiece 85
Masterpiece + 95
150 Watt Power Supply 69

Boards

AST
Rampage/2 **Call**
Rampage 286 w/512K \$299
Sixpac Plus w/64K 129
All Other AST Products Call
EVEREX
2MB Above PC/XT w/o Mem 79
3MB Above AT w/o Mem 89
ORCHID
Ram Quest Extra PS/2 **Call**
INTEL
Above PC 64K 225
Above 286 w/512K 344
Orchid Tiny Turbo 289

COMPUTERS

EVEREX
286, 10MHz, 0 Wait \$1149
286, 10MHz, 1 Wait 999
286, 12.5MHz, 0 Wait 1349
ACER
710 w/o Monitor **Call**
900 w/o Monitor **Call**
SHARP
PC 4501 \$765
PC 4502 **Call**
PC 4521 **Call**
AT&T
6286 WGS 1499
6300 WGS 919
6386 WGS, 40 MB H.D. 2999
6386E, 135 MB H.D. 4599
ZENITH
Super Sport 286/20MG **Call**
Super Sport 8088/2-Floppies **Call**
Super Sport 8088/20MG **Call**
NEC
Multispeed-2 **Call**
All Other NEC Products Call

Hard Cards

Plus 20 MB \$529
Plus 40 MB 659

Hard Drives

Seagate ST-225 20 MB w/cont \$265
Seagate ST-238 30 MB w/cont 295
Seagate 40 MB AT 251-2 **Call**
Seagate 80 MB AT 579
Seagate ST-125 w/cont 329
Seagate ST-138 w/cont 399
Priam **Call**

Monitors

AMDEK
410 Amber \$145
MAGNAVOX
RGB 255
SIGMA
Laserview + 19" **Call**
SAMSUNG
Flat Amber **Call**
TTL Amber w/tilt 76
Color w/tilt 249
VIKING **Call**

Printers

CITIZEN
MSP 40 \$285
120 D 146
MSP 50 385
EPSON
LQ 500 349
LQ 850 559
FX-850 **Call**
LASERS
Other Lasers **Call**
AST TURBO PS **Call**
OKIDATA LASERLINE 6 1379
OKIDATA
OKI 320 **Call**
OKI 321 **Call**
OKI 390 489
OKI 391 679
STAR MICRONICS
NX 1000 179
NX 1000 Color 238

CHRISTMAS SPECIALS

EPSON EQUITY 1 PLUS \$749
EPSON FX-86E PRINTER 299

EGA Boards

AST VGA + (16 Bit) \$320
ATI EGA Wonder 800 229
Genoa Super EGA Hi-Res + 186
Orchid Designer 309
Paradise Auto 480 179
Paradise VGA Plus 269
Paradise VGA Prof. 399
Vega VGA 275
All Other EGA Products Call

Modems

AZ 2400 INT w/o Soft \$129
Everex 300/1200 w/ Soft 69
Everex 2400 EXT, Error Cor. 189
Hayes 1200 EXT w/o Soft 299
Hayes 1200B INT w/ Soft 289
Hayes 2400 EXT w/o Soft 435
Novation Parrot 1200 w/Soft 99
U.S. Robotics 2400 w/o Soft 335

EGA Monitors

Casper \$410
Princeton Ultra Scan 539
Mitsubishi Diamond Scan 509
NEC - Multisync II 599
Zenith 14" Flat Screen 650

Mice

Genius \$49
Logitech 68
Microsoft Bus w/Painbrush 92
Microsoft Serial 92
Optimouse w/Dr Halo 89
Optimouse w/DPE 185

TERMS: Shipping minimum is \$5.00. AZ orders + 6.7% sales tax. Personal check/company check - allow eight (8) days to clear. We accept purchase orders from authorized institutions for 3.5% more than cash price. All returns are subject to our approval. There will be a 20% restock fee. Minimum phone order \$50. All prices are subject to change. Due to copyright laws we cannot take back any open software.

WAREHOUSE DATA PRODUCTS

2727 West Glendale Ave. • Phoenix, AZ 85051

We do not guarantee compatibility



No Charge for
MasterCard or Visa

Servicing our PC buyers with
low pricing and technical
experience since 1979.

Phone Hours:
Monday thru Friday 6:30 am-9:00 pm.
Saturday 9:00 am-5:00 pm MST.



ATTENTION: dBASE III PLUS Programmers & Developers

Increase your dBASE III PLUS™ program speed up to 15 times!

Design and distribute compiled dBASE programs royalty-free!

Protect your vulnerable source code from inquiring minds!

Develop dBASE applications without dBASE III PLUS!

dBFast \$99.00

... a powerful MS-DOS compiler for the dBASE III PLUS language which explodes storage and performance restrictions imposed by other, much more expensive compilers.

Lightning Compilation Speed

Maximize programming and testing efficiency. dBFast's unique memory-resident "Engine" (only 87K) compiles typical dBASE III PLUS programs in just 3-6 seconds with no linking step required.

Incredibly Fast Execution

dBFast compiled programs run up to 15 times faster than interpreted dBASE. On independently developed test suites, dBFast has proven time & again that something indeed... *outruns the fox!*

Small, Efficient .EXE Files

With no bulky run-time library to clutter your .EXE files, dBFast compiled programs consume as little as 2K of disk space! Typical Programs take 5-30K.

Hassel-free Multi-User Conversion

dBFast's Autolock command enables multi-user/LAN protocols in one short line of code. Eliminates system lockups and data collision!

dBFast/Mac \$199.00

... a rich, interactive "Programming Environment" that allows you to combine the power and versatility of the dBASE III PLUS programming language with the intuitive human interface of Macintosh!

Interactive Programming Environment

Maximize your programming efficiency with dBFast/Mac's interactive compiler/editor. Develop, compile, debug, and run your applications - on the fly - without ever leaving this powerful programming environment.

Accelerated Program Execution

dBFast/Mac compiled programs run up to 200 times faster than interpreted dBASE. On independently-developed test suites, dBFast/Mac is up to 30% faster than FoxBASE+/Mac™!

Language Extensions For Mac's Friendly Interface

Easily implement the powerful Macintosh user interface adding mouse support, pull-down menus, multiple windowing, and click-on buttons to your dBASE programs.

dBASE III PLUS Portability

Capitalize on your prior MS-DOS development efforts by porting your existing .PRG and data files to dBFast/Mac where you may easily add the powerful Macintosh interface. Data files transfer as well, eliminating the need to rekey your data.

Sold By Quality Software Dealers Throughout The World

For Sales Information, Please Call (800) 356-6356

dBFast, FoxBASE+/Mac, Macintosh, and dBASE III PLUS are trademarks of dBFast, Inc.,
Fox Software, Apple Computers, Inc., and Ashton-Tate, respectively.

lection of useful junk, including toll-free phone numbers, metric conversions, area codes, and, yes, DOS help.

I recommend MemoryMate to everyone, without reservation. It has been a truly great program all along, and now it's even better. However, MemoryMate is no longer alone at the top of the heap. I just received the latest version of Tornado (Micro Logic, \$99.95), and I'm finding it very appealing.

The underlying philosophy is the same—both Tornado and MemoryMate are designed to keep track of odd pieces of information—but the two programs take different routes to get to the same goal. MemoryMate uses full-screen records, while Tornado employs lots and lots of windows. I once described an early version of Tornado as "looking like Framework gone mad," and the phrase is still apt.

Tornado lets you make little notes to yourself and organize them into stacks of related material. Like MemoryMate, you can search on a keyword, but Tornado also lets you flip through a stack of windows. Tornado optimizes screen appearance every time a new window is brought to the top of the stack, and occasionally things jump around a little, but this is unsettling only the first few times you use the program.

Tornado seems to be a bit quicker than MemoryMate, but its windows are generally smaller than MemoryMate records. Tornado is a much more visual program, though. And it lets you create templates, so you can enter your data into convenient forms, a feature that is lacking in MemoryMate.

On the whole, the two programs seem about equal. Both are top-notch, and I highly recommend both of them. Probably the major difference is stylistic rather than structural; I'd suggest looking at both of them before making your decision.

I think I'd prefer to use MemoryMate on a big hard disk drive—system for long-term storage; Tornado strikes me as better suited to quick reminders and a laptop environment. But whichever you choose, get one or both of them. Either program can make your life a lot easier. ■

Ezra Shapiro is a consulting editor for BYTE. You can contact him on BIX as "ezra." Because of the volume of mail he receives, Ezra, regretfully, cannot respond to each inquiry.

Your questions and comments are welcome. Write to: Editor, BYTE, One Phoenix Mill Lane, Peterborough, NH 03458.

What's Your Excuse?

Over the years, we've heard a lot of excuses.
We thought it was time to set the record straight.

The ten most used excuses for not buying FLASH *The Disk Accelerator*.

1. It won't work for me because I've got extended memory!
2. My machine runs fast as it is!
3. Installing TSR's is too complicated!
4. Disk Cache?
5. I got one from IBM free!
6. Disk caches won't speed up floppies; that's all my portable has!
7. They're all the same!
8. I've heard disk caches will blow up my drive!
9. I've already got one, why spend more money?
10. All of the above.

FLASH is the hands down winner...
A feature rich caching program with adjustable Cache sizes and support for extended memory. Still the best caching software for your money."
- Winn L. Rosch, PC Magazine
November 24 1987 -



The ten best reasons for buying FLASH *The Disk Accelerator*.

1. LIGHTNING won't work for you but FLASH will! FLASH not only accesses AT extended memory but uses AT extended, EMS expanded and conventional memories separately or in any combination of the three.
2. This is one of the biggest misconceptions! The fact is, the faster your processor the more you need a disk cache. Your 386 system won't be running at top speed until FLASH is installed!
3. We take pride in how hard we work to make your work easier. FLASH comes equipped with an organized, easy to use, easy to understand manual and command language. Not to mention, a sensible menu installation and command help screen!
4. We want everyone to be familiar with the fantastic benefits of increased system speed. We encourage you to call us or see your local dealer for information!
5. You get what you pay for!!
6. The popularity of portable systems has our competition scrambling to create a program that does cache floppies. FLASH, however, has been there all along. In fact, FLASH will buffer a whopping 26 device driven drives!
7. Please, don't be misled. FLASH, because of it's wide range of options and superior speed, is guaranteed to be the fastest and most versatile cache on the market. PC Magazine seems to agree!
8. Most can, but FLASH won't! Its unmatched level of compatibility helps generate the safest information transfer available!
9. Why? Because it's well worth the price! We want you to find that out. And, the price can't be beat. If you already own a disk cache we'll sell you FLASH for just \$19.95! Call for more details!
10. There aren't any reasons not to!

FLASH stands at the top of its class...
FLASH offers all the options of LIGHTNING and more."

- Whitney Bolton, Byte Magazine
April 1987 -

"Better than several others... a clean little program... impressive!"

- Howard W. Sams & Co. Publishing -

Editor's Choice

FLASH *The Disk Accelerator*.
from



\$69.95



Please call today 1-800-25 FLASH CACHE OWNER \$19.95
or see your local dealer.

Software Masters Inc.

6352 North Guilford Ave.

Indianapolis, IN 46220

(317) 253-8088



DO PRODUCTIVITY TOOLS HELP PRODUCTIVITY?

Selecting the right package is like walking through a minefield. It's easier to take the wrong step than the right.

When's the last time you made a luncheon date with someone who keeps appointments on his or her computer? You probably remember the event. "Are you free for lunch on Thursday?" you ask. Then you wait.

First you hear some beeping on the other end of the phone while the person you're talking to gets out of Lotus 1-2-3 or WordPerfect or whatever. Then he or she runs the appointment calendar program, finds the proper date, and types you in. Seems to take forever, doesn't it? It all seems like a lot of trouble, when all you had to do is take your Day-Timer out of your pocket and write in the date.

As this example illustrates, not everything that bills itself as a software productivity tool does much that's positive for productivity. On the other hand, other packages billed as productivity tools are quite helpful. How helpful depends on what the program is designed to do and how well it does it.

What Is a Productivity Tool?

Before I get too deeply into this discussion, it's not a bad idea to decide exactly what a productivity tool is. The problem is that there's little agreement among users on the exact definition. Too, the waters are muddied by those who, if they can't think of something else to call it, define their software as a "productivity tool."

The other reason for confusion about productivity tools is that there are at least two types. There are those aimed at what

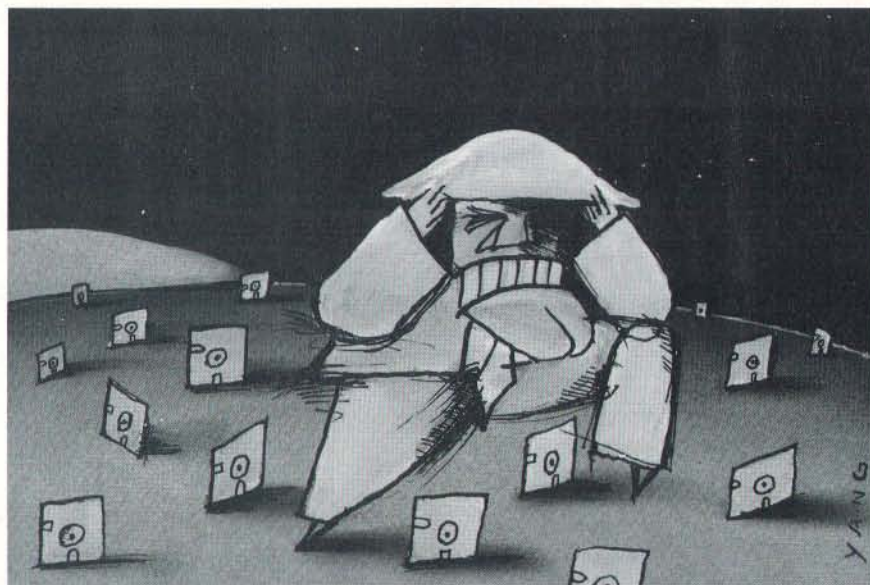

are essentially vertical markets. That is, they are aimed at a single specific segment of the market and are intended to accomplish work only in that field. A good example of these packages are editors for programmers, such as the SideKick editor or the Condor editor. Likewise, an on-line thesaurus such as Word Finder is a productivity tool for writers. Systems analysts might use Index Technology's Excelerator to help in system design.

Then there are the tools aimed at horizontal markets. They are intended to be used by nearly anyone in nearly any business. A good example is SideKick's appointment calendar or its phone dialer. Borland once had the field to itself. But now such packages as Prodex and Take Charge have entered the picture. On a grander scale, there's GrandView, which promises managers to improve productivity.

The Vertical Approach

If there's one area where productivity tools are really likely to shine, the verti-

cal market is it. Generally, vertical packages are developed by people who actually use them. Programming editors are developed by programmers, for example. Provided you like the approach they use, chances are these packages will, indeed, enhance your productivity.

The secret to success of the vertical market tools is that they don't even attempt to be all things to all people. They simply take aim at a particular function, such as the programming editors mentioned above, and try to make that function easier to handle. If you're shopping for these types of tools, you've got a good chance of finding something that will help whoever's going to end up using the tool. You will need to take care, though, that the tool you select actually does what the user wants.

The Horizontal Approach

Trying to select the proper type of horizontal productivity package is like walking through a minefield. It's infinitely easier to take the wrong approach than

continued

"Give me one good reason to give up C."

"How about 43?"

Modula-2 saves more time and money than any other programming environment.

1. High-level language
2. Readable, maintainable code
3. Ideal for team programming
4. Supports multi-tasking
5. Emerging international standard
6. Pascal or C programmers learn it in hours
7. Language for modern engineering
8. Consistency checks across modules
9. User control over exported/imported objects
10. Traps most programming errors
11. Fewer bugs in final code
12. Easy low-level access

The LOGITECH Modula-2 programming environment goes far beyond the language.

13. Faster project throughput
14. Corporations rely on it
15. Adds a rich set of tools to the language
16. Best debuggers for any language
17. Configurable, easy-to-use text editor
18. Integrated environment
19. Powerful windowing interface
20. Compiles twice as fast as MS-C
21. Code as fast as the best C compilers
22. Mature and reliable
23. Extended library
24. Standard object format
25. C libraries can be used
26. Supports EGA 43-line mode
27. Automatic MAKE
28. Flexible overlays
29. Price/performance leader

Items Discussed

Condor Editor\$129.95
 Condor Computer Corp.
 1490 Eisenhower Place
 Ann Arbor, MI 48108
 (313) 971-8880
Inquiry 961.

Day-Timer\$13.45 to \$82
 Day-Timers, Inc.
 1 Day-Timer Plaza
 Allentown, PA 18195
 (215) 395-5884
Inquiry 962.

Excelerator\$8400
 Index Technology Corp.
 1 Main St.
 Cambridge, MA 02142
 (617) 494-8200
Inquiry 963.

GrandView\$295
More\$395
 Symantec Corp.
 117 Easy St.
 Mountain View, CA 94043
 (415) 964-6300
 (408) 253-9600
Inquiry 964.

Prodex\$89.95
 Prodex Development Co.
 P.O. Box 31515
 Seattle, WA 98103
 (206) 527-2898
Inquiry 965.

SideKick\$99.95
SideKick Plus\$199.95
 Borland International
 1800 Green Hills Rd.
 Scotts Valley, CA 95066
 (408) 439-1060
Inquiry 966.

Take Charge!\$139.95
 Departmental Technologies, Inc.
 131 Washington St., Suite 200
 Lodi, NJ 07644
 (201) 786-6878
Inquiry 967.

the right one. The reason is simple.

These products generally attempt to perform some computer function you are already doing in another way. When you adopt the tool, you have to change your habits and your way of doing your job. This is not to say that your habits don't need changing. They might. But if you're going to change them, before you buy, you need to make sure that the new way actually works well with the way you do business.

Let's look at Borland's SideKick, for example. This was one of the first of the memory-resident productivity tools. Recently, it has been supplanted by a new version, SideKick Plus, a program that operates on the same principle as the SideKick clones that are available. They all give you access to a set of memory-resident tools that are supposed to make your job easier by running in the background so you can access them at the same time you are operating another program.

If you spend nearly all your time at your desk with your computer turned on

and don't have processes running that conflict with memory-resident programs, SideKick can be a real plus. No matter what you're running at the time, you can open a window on your screen and make a note, set up an appointment, or look up a number. Under those circumstances, it's pretty handy.

But if you spend a lot of time out of the office, either in meetings or on the road, how can you use SideKick?

This situation illustrates the problem with productivity tools that depend on your computer. You have to be using the computer to make use of them. I suspect that the copies of SideKick and its clones that sit unused on hard disks number in the tens of thousands.

These packages are unused because their owners found that it was easier to use their Day-Timers to keep appointments or phone numbers than it was to use their computers. The reason may be as simple as their having to share the computer with a coworker. Or they may spend a significant amount of their day in meetings in rooms where there aren't any

DOWN TO BUSINESS

computers. Despite their many advantages, IBM PCs or Macintoshes still can't be slipped into your coat pocket when you head for a meeting.

Deciding What You Need

Now that we've discussed what can go wrong with productivity tools, let's talk about what can go right. There are, after all, many such packages that are worth buying, or people wouldn't be buying so many of them. You need to see what suits your particular style of work before you can take advantage of their features, however.

The first thing you need to decide is whether you spend a lot of time at the computer. If you don't, a computer-based productivity tool will be of limited value to you. You also need to consider whether you have access to a computer when you are at your office. If you have to share a PC with six other people, it may not be handy when you need to be productive.

Once you have arrived at the conclusion that you really are at the computer most of the time and that you are the person who usually has access to it, you must explore what you need in order to be productive. Your decision depends heavily on what you actually do at the office. Are you a programmer who spends much of the day typing in code? Then one of the tools developed specifically for programmers could make a big difference to your work, but a phone dialer is probably not necessary.

On the other hand, if your Rolodex has had its 100,000-mile checkup in its second year, maybe an address list and a phone dialer really are a good idea. If so, chances are you wouldn't benefit a great deal from an editor that automatically produces the indentations for C source code.

Once you decide what functions you would actually use, you should go to the software store and try the packages yourself. Each productivity package is a little different, and since these tools have to fit your personal work habits so closely, their subjective feel is quite important. Even if a package has every feature you'd ever want, you won't use it if it feels clumsy to you.

While you're checking things, take a look at the documentation. If you're helping other users select their software, it will help a lot if you can read and understand the manual. An example of this is a package called Take Charge! from Departmental Technologies. This product has aspects of a number of other productivity tools, making the manual

A *nalyze
your job and the way
you perform it to decide
whether one of these
tools really will help
you.*

reasonably important, but the text is so small that it's nearly impossible to read. It looks like they photoreduced a full-size page until it was the size of a paperback book.

Manager's Tools

While there are those who would argue that the use of the terms *productivity* and *manager* in the same sentence is an oxymoron, there are a number of tools becoming available that are aimed specifically at the manager. These tools are understandably quite different, since a manager's job can be extremely varied. GrandView (for IBM compatibles) and More (for the Macintosh) from Symantec are examples of this concept.

GrandView and More are extremely flexible outlining programs. I think they are billed as management tools because of their flexibility. You can create outlines, fill them in, turn them into memos, and arrange them by categories. If this is the way you manage, these features could be useful. On the other hand, these activities may be done by more junior-level people. You have to look at your work and decide.

Do They or Don't They Help Productivity?

It depends. You have to analyze your job and the way you perform it to decide whether one of these productivity tools really will help you get your work done easier and faster. It might be that they won't. ■

Wayne Rash Jr. is a member of the professional staff of American Management Systems, Inc. (Arlington, Virginia), where he consults with the federal government on microcomputers. You can reach him on BIX as "waynerash."

Your questions and comments are welcome. Write to: Editor, BYTE, One Phoenix Mill Lane, Peterborough, NH 03458.



Announcing Modula OS/2. The operating system finally catches up with the language.

30. Support for dual mode operations
31. Dynamic link libraries
32. For standard/extended version of OS/2
33. Multiple threads
34. Virtually unlimited program size
35. Makes mixing languages easy
36. Most powerful editor under OS/2
37. Background compilation while editing
38. Run-time checks
39. Stack checks even in threads
40. OS/2 uses Modula-2 parameter passing mechanism
41. Upgrade available for Modula-2 DOS users
42. Direct Hotline and free Bulletin Board support for all Modula-2 products

43. It's affordable!

Call toll-free:
800-231-7717
In California:
800-552-8885

Please send me:

- | | |
|---|------------|
| <input type="checkbox"/> Modula-2 Compiler Pack (DOS) | \$ 99.00 |
| <input type="checkbox"/> Modula-2 Toolkit (DOS) | \$ 169.00 |
| <input type="checkbox"/> Modula-2 Development System (DOS, includes Compiler and Toolkit) | \$ 249.00 |
| <input type="checkbox"/> Modula OS/2 | \$ 349.00 |
| <input type="checkbox"/> Modula-2 VAX/VMS version | \$2,500.00 |
| Shipping & Handling (per item) | \$ 6.50 |
| CA residents add applicable sales tax | \$ _____ |
| Total | \$ _____ |
| <input type="checkbox"/> Check/money order included | |
| <input type="checkbox"/> Visa <input type="checkbox"/> MasterCard | |

Card Number Exp. Date

Cardholder Name

Authorized Signature

Ship to:

Name

Address

City

State

Zip

Phone

Offer valid in U.S. Only Dealer Inquiries welcome.
Educational prices available. BY1088

Send to:

**LOGITECH**

Logitech, Inc.
Attn: Coupon Redemption Program
6505 Kaiser Drive, Fremont, CA 94555

In Europe, contact:
LOGITECH SA in Switzerland
Tel: ++41 (0) 21-869-96-56
In the United Kingdom, contact:
LOGITECH UK
Tel: ++44 (0) 525-22-22-11

We've Invented the Future of Instrumentation Software . . . Twice.

With Words

With Pictures

Acquisition

Integrated libraries for GPIB, RS-232, A/D-D/A-DIO plug-in cards, and modular instruments.

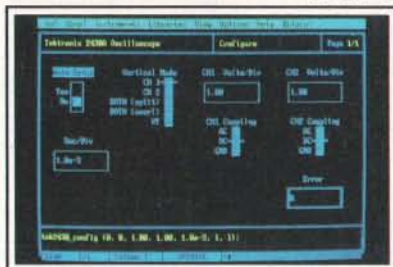

Intuitive character-based function panels that automatically generate source code.

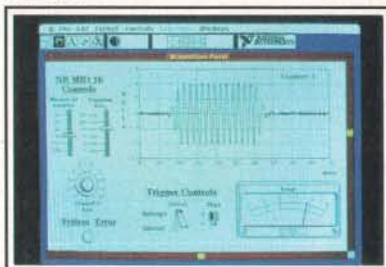

Front panel user interface with virtual instrument block diagram programming.

Analysis

Extensive libraries for data reduction, digital signal processing, and statistical analysis.

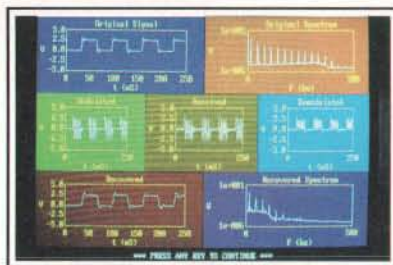

Over 100 analysis functions plus all the built-in functions of your language.

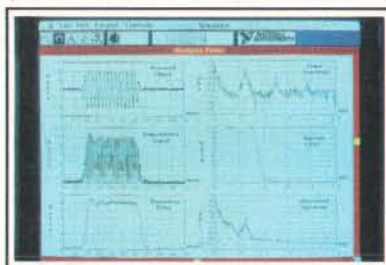

Over 250 icons for computation and analysis.

Presentation

Flexible high-performance graphics and report generation.

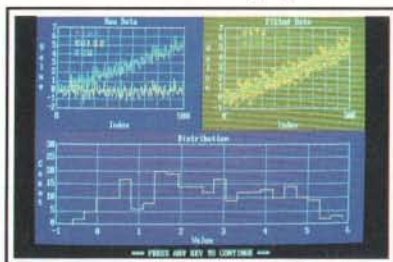

Extensive graphics support for CGA, EGA, MCGA, VGA, and Hercules.

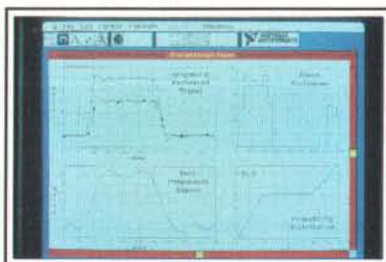

Macintosh Desktop Publishing compatibility.

The Software is the Instrument

LabWindows™—
for the DOS-based PC and PS/2,
with Microsoft QuickBASIC or C.

 **NATIONAL
INSTRUMENTS™**
12109 Technology Boulevard
Austin, Texas 78727-6204
800/531-4742 512/250-9119

LabVIEW®—
for the Apple Macintosh



HOT STUFF

The products
that outshined the rest
in the halls
of MacWorld Expo

Another MacWorld Expo has come and gone, this time from a sweltering Boston locale. MacWorld Expo has become a big deal: too big, in fact, for the show organizers, Mitch Hall Associates/World Expositions. The show bridged four hot, humid days in August, and it was spread over three different locations (the World Trade Center, the Bayside Expo Center, and the Wang Center), each one inconvenient to reach through the legendary, even insane Boston traffic.

Although the show attracted more exhibitors and attendees than ever before, it was painfully evident that the facilities and conference were both being strained to their limits. As happened in August 1987, the air conditioning at the Bayside Expo failed on Thursday, and at the World Trade Center it lacked sufficient cooling power to keep the crowds comfortable. The Wang Center was cooler, but was used only for keynote speeches and panel discussions, not vendor booths.

Although attending the show was an exercise in patience and perspiration, I had a chance to try out a number of interesting new Mac products. This Expo is best characterized by the evolutionary nature of the products shown, rather than any revolutionary ones. The show finally brought home to me just how far the Mac has come in 4 years. There is no doubt that the Mac is now taken as a Serious Business Machine by vendors. Just counting the number of new Mac-to-mainframe communications products at the Expo took me the better part of an afternoon.

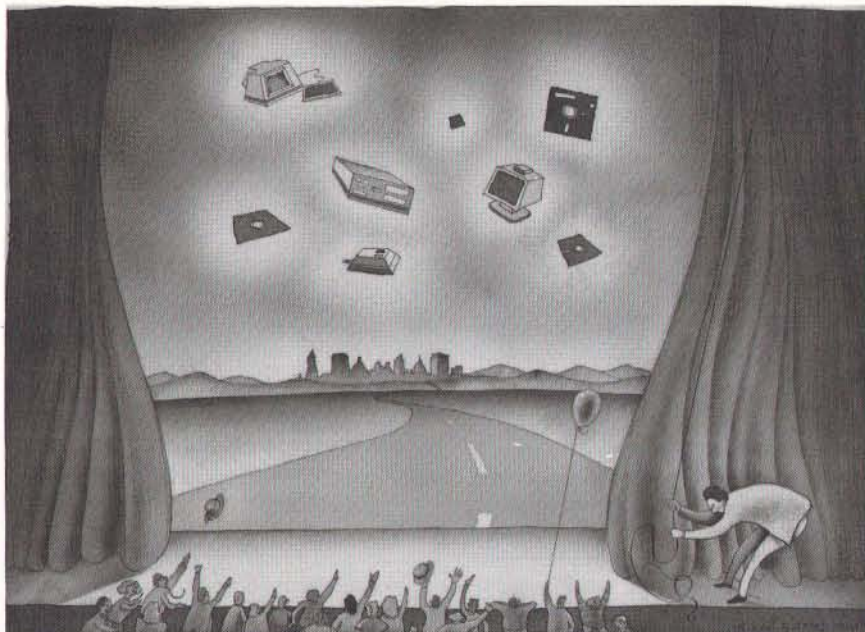

While it's gratifying to see the Mac recognized by business for the powerful tool it's always been, I also have a feeling of sadness. The Mac is no longer the cultural icon it had been, venerated by hobbyists, hackers, and academics. Fortunately, the Expo still had space for plenty of "small" products that don't offer every gee-whiz feature and cost a bundle. The Expo proved that Mac entrepreneurship is alive and well, thank you.

Hard Disk Salvation and Communications Products

1stAid Software's 1stAid Kit has saved my bacon on more than one occasion by recovering files from disks I had zapped by mistake. When I saw the new version (2.5) at the Expo, I was even more impressed. The application is a complete package of utilities that recovers seemingly lost files from disks that have crossed the great divide. The newest utility is called Quick Cure, and it lives up to its name. It makes fast work of scanning

bad disks (hard or floppy), diagnosing problems, and recovering lost or damaged files. Like the earlier 1stAid Kit versions, 2.5 will work with any HFS version of the System and Finder, including the newest release, System Tools 6.0. At \$99.95, 1stAid Kit is a bargain.

If I could point to a dominant theme at the Expo, it would be the maturation of Macintosh networking and communications products. A bunch of companies have upgraded earlier communications products that connect the Mac to corporate mainframes (IBM, DEC, etc.), using just about every communications protocol and access method known to mainframedom. These programs now offer reliability and full MultiFinder support, where they once were kludgy and flaky.

Another category of improved communications products includes those that permit customized applications. Connect, the company that offers the MacNet

continued

Items Discussed

Acknowledge\$495 SuperMac Software P.O. Box 390725 295 North Bernardo Ave. Mountain View, CA 94039 (415) 964-9694 Inquiry 841.	DirectPrint under \$4000 Jasmine 1740 Army St. San Francisco, CA 94124 (800) 347-3228 Inquiry 843.
DaynaMail for five Mac nodes\$295 Dayna Communications, Inc. 50 South Main St., Fifth Floor Salt Lake City, UT 84144 (801) 531-0203 Inquiry 844.	DirectTape \$1099 when purchased with a DirectDrive hard disk drive\$899 Jasmine 1740 Army St. San Francisco, CA 94124 (800) 347-3228 Inquiry 842.
DaynaTalk per Mac node\$189 per IBM PC node\$289 Dayna Communications, Inc. 50 South Main St., Fifth Floor Salt Lake City, UT 84144 (801) 531-0203 Inquiry 845.	1stAid Kit 2.5 \$99.95 1stAid Software, Inc. 42 Radnor Rd. Boston, MA 02135 (617) 783-7118 Inquiry 840.

on-line service, announced a special toolkit called the Connect Protocol Manager that permits developers to write custom applications for accessing MacNet.

Another product, Acknowledge, from SuperMac Software, carries this custom communications theme even further. Acknowledge generalizes the concept of creating communications applications so you can write custom programs that run on the Mac and effect seamless connections to any remote computer or on-line service. Acknowledge is a development system for producing end-user Mac communications applications that don't require modification of the remote host's communications software or protocols.

Acknowledge includes its own programming language, TAL (Telecommunications Access Language). TAL allows you to build true Mac applications with pull-down menus, icons, dialog boxes, and so on. Acknowledge also includes some sample applications to help you get started, although TAL is straightforward enough that it doesn't present a steep learning curve for professional programmers.

The sample Acknowledge applications show that the programs you create can be made to look and work like popular single-purpose communications programs, such as DeskTop Express, CompuServe Navigator, and AppleLink.

Backing It Up

In September I reported on the very reliable and fast Tecmar QT-Mac40 DC-2000 tape drive. I'm happy to report that Tecmar has found an OEM for its drive: Jasmine. Jasmine calls the drive DirectTape, and it's virtually identical to the Tecmar-labeled unit, including similar backup/restore software. I used the tape for about an hour at the show (admittedly a poor test of reliability), and it did indeed work just like the Tecmar unit. Both Tecmar and Jasmine assured me that the drive was functionally identical to the Tecmar drive, and I'd expect it to be equally reliable. In any case, it's nice to see that a good device is being sold by another reliable vendor.

Jasmine has priced the drive at \$1099, almost \$300 lower than Tecmar. If you buy it in conjunction with any Jasmine hard disk drive, the price drops even farther to \$899. The price includes a t-adaptor with a 25-pin Mac small-computer-system-interface connector and two 50-pin standard SCSI connectors, so you can plug your DirectTape into just about any existing SCSI cabling setup. The price also includes two preformatted DC-2000 tapes, so you can use the drive as soon as you've hooked it up. Jasmine has taken the solid Tecmar drive and repackaged it as a better value. If you still haven't bought a backup device, check it

out. Come to think of it, at \$1099, you might want to dump your current slow backup drive (like the Apple 40SC) and buy the Jasmine.

DirectPrint

Although Jasmine introduced several other new products at the show, I was most impressed with the DirectPrint printer. The DirectPrint, which should be shipping by the time this column hits the streets, is a PostScript printer that includes 3 megabytes of RAM and 35 PostScript fonts embedded in 1 megabyte of ROM.

It's small, about 35 pounds, and takes up only a moderate amount of desk real estate (16 inches wide by 13½ inches deep). It's also fairly fast, with an average throughput of 6 pages per minute. The 4-MHz Weitek XL-8200 processor keeps the printer near its rated speed by composing pages quickly. The DirectPrint can be connected to your Mac by using AppleTalk, a Centronics parallel port, or an RS-232C serial port. It also includes an Apple Desktop Bus port for future connectivity options that Jasmine only hinted at. Jasmine says the DirectPrint will cost under \$4000.

Although these are good specifications and the price is attractive, the really interesting point about the DirectPrint is that it's *not* a laser printer. Instead it uses a much newer technology: a liquid-crystal shutter-marking engine, the Casio LCS-130. This 300-dot-per-inch printing engine produces blacker blacks than the Canon LBP-SX laser engine or an Apple LaserWriter IINTX. It also lacks the rotating and swiveling imaging mirrors common to some laser printers, which should mean that the printer won't suffer from scanning distortion. This also means that long-term reliability will be high (remember the equation: fewer moving parts = higher reliability).

Putting It in the Mail and Getting It There Quicker

I've never really thought highly of the current crop of electronic mail packages available for the Mac (InBox and Microsoft Mail spring to mind). Oh sure, they work as billed, but their interconnectivity is not great (you can't use them easily across interconnected networks of machines other than Macs), and their mail-handling features are pretty basic.

Enter DaynaMail. This new mail system works on both Macs and IBM PCs. It supports network connections through AppleShare, Novell's NetWare, 3Com's 3+, and Sun's TOPS. It can also com-

continued

New diskdoubler™

*doubles the storage capacity
doubles the storage capacity
of your hard disk*

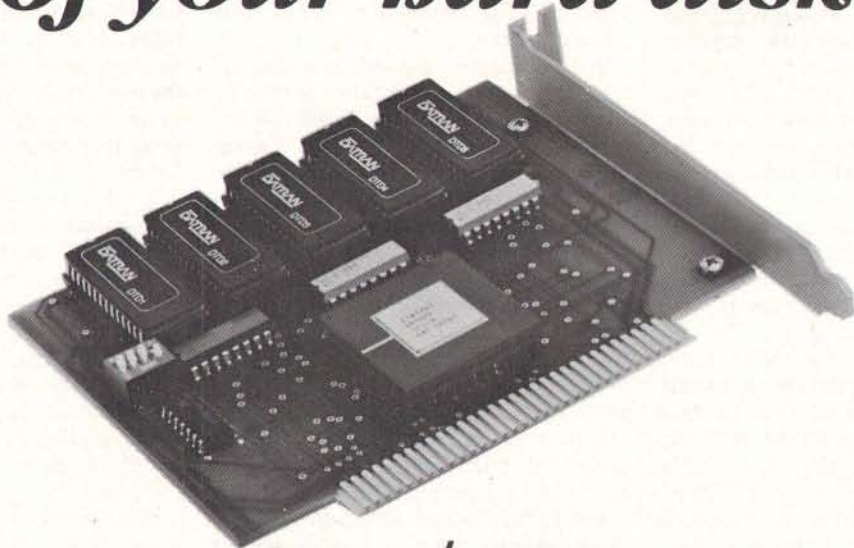

for \$189

Upgrade the disk drive in your PC the easy way!

Datran's new DiskDoubler dd2000 is a short card that simply fits into any available slot on an IBM, PC, XT, AT, 386 or compatible, DOS 2.0 or greater.

Upgrade a 20 MB disk into a 40 MB. The DiskDoubler lets you double the storage capacity of any hard disk *without loss of performance*. No matter what size hard disk you have, the DiskDoubler will double it.

Works With All Data. The DiskDoubler compresses data stored on a hard disk, including application programs, program files, COM and EXE files. You will appreciate the doubling of capacity for word processing, spreadsheets, and database files.

Powerful dBASE Capacity. The DiskDoubler is especially powerful when handling dBASE II, III and III Plus files, storing on the average *three times* as much data on your hard disk, i.e., your 20 MB hard disk will perform like a 60 MB disk... an 80 MB disk will act like a 240 MB model. It works equally well for any size hard disk... and for only \$189.00.

Principle of Operation. At the heart of the DiskDoubler is a new, powerful high-speed data compression microprocessor that incorporates Datran's state-of-the-art data compression technology, which represents years of research and development.

Totally Transparent Operation. Datran's high speed data compression technology coupled with our extensive operating software allows the DiskDoubler to process data at speeds compatible with disk operating speeds. It looks as though you've added a disk drive of double the capacity to your PC.

Breaks the 32 MB DOS Barrier. Because the DiskDoubler doubles the amount of data your disk drive stores, it effectively increases the 32 MB DOS barrier to 64 MB without any special software.

Simple Installation. Once the simple, fast installation is complete, the DiskDoubler operates in the background and is completely user transparent. The dd2000 works with yours existing hard disk controller.

No Formatting Required as is necessary with RLL controllers. DiskDoubler will even double the capacity of a drive already using RLL technology.

Low Power Consumption. The 1/2 watt DiskDoubler eliminates the need for upgrading your power supply, as would be needed if an additional disk drive were added pulling 15 to 30 watts.

Long Life Performance. With a long three-year limited warranty, DiskDoubler is a simple, inexpensive and reliable way to double your disk storage.

Satisfaction Guaranteed. Datran backs the DiskDoubler with a 30-day no questions asked money back guarantee.



FOR THE DEALER NEAREST YOU OR
TO ORDER DIRECT BY PHONE:

1-800-332-0456

DATRAN

Leadership in Data Compression Technology

municate with any application on remote computers that is compatible with Action Technologies' MHS communications package. MHS-compatible products include IBM's PROFS, DEC's All-in-1, and Action Technologies' The Coordinator. This connectivity gives DaynaMail serious wide-area capabilities that should be attractive to computing environments like mine, where you have to make disparate computers communicate with each other over every cabling scheme and network setup known to humanity.

DaynaMail works as an application on an IBM PC and as a desk accessory on a Mac. The program is server-based, and any machine on the network can be designated as a DaynaMail server. You can also set up multiple servers on the same net to better distribute the message load. I tested some of the mail database features at the show, and all of them worked as billed: message sorting by multiple criteria, saving and restoring unfinished draft messages, attaching any file to a message, sending blind carbon copies, message receipt and message opening notification, mail address lists, multiple

address books, incoming mail alert, and several others.

In my brief time testing DaynaMail, I was hooked. I'm already set to test it in a full-blown configuration here at the university. I'll have more to say about how it works in the real world over the next couple of months.

All of you who are sick and tired of waiting for your AppleTalk network to clear so your LaserWriter job prints, raise your hands. AppleTalk is a great idea. Building a network into the Mac was a stroke of genius on Apple's part. But now that we're all hooked on this network, the fact is it's *too bloody slow!* 230K bits per second over LocalTalk or PhoneNet cabling just doesn't cut it anymore.

Sure, we can buy Mac IIs and migrate to EtherTalk and its 10-megabyte-per-second bandwidth, but that's a pretty expensive solution. Well, hold off on those EtherTalk purchases, because DaynaTalk has just been released.

DaynaTalk is a small (2- by 3- by 1-inch) hardware module that replaces your LocalTalk or PhoneNet node and plugs into your existing network. It boosts the

data-transmission rate to as high as 850K bps for each Mac and as high as 1.7 megabits per second for each PC on the net. You'd be surprised at the difference between 230K bps and 850K bps.

DaynaTalk works by varying the transmission rate over the network; it takes advantage of periods of light usage to cram more AppleTalk packets down the pipe. I expect to test the devices soon in my own labs, so I'll have more to say about this magic network accelerator in a future column. For now, it's enough to know that it really works; it's completely transparent to the network; it's fully compatible with TOPS, AppleShare, and NetWare Mac; and it costs but \$189 for each Mac, and \$289 for a PC. ■

Don Crabb is the director of laboratories and a senior lecturer for the computer science department at the University of Chicago. He is also a consulting editor for BYTE. He can be reached on BIX as "decrabb."

Your questions and comments are welcome. Write to: Editor, BYTE, One Phoenix Mill Lane, Peterborough, NH 03458.

PRICE
SLASHED!

FREE
Software!



THE 3.5" CONNECTION!

The perfect solution for upgrading your existing PC/XT/AT to "State Of The Art" 3.5" floppy disk technology! The Model 853W (720K) and Model 873W (1.44MB/720K) 3.5" drives are "drop-in" replacements for 5.25" drives! Disk format is fully compatible with popular Laptops (IBM, Toshiba, Zenith, etc.) and the new IBM PS/2 models. Both units come completely assembled and contain everything that you need, including Premium SONY drive, interface adapters, software device drivers and complete documentation. These drives utilize your existing controller so no additional slots are required (1.44MB requires AT class controller or special PC/XT High-Density Controller available from Tigertronics). Available with gray or black bezel (specify).

Model 853W
(720K)
~~\$159.95~~
\$129.95

Tigertronics
INCORPORATED

Model 873W
(1.44MB)
~~\$229.95~~
\$159.95

400 Daily Lane • P.O. Box 5210
Grants Pass, Oregon 97527



IMMEDIATE DELIVERY!
Call 503 474-6700 or 503 474-6701
FAX 503 474-6703



A MESSAGE TO OUR SUBSCRIBERS

FROM TIME TO TIME WE MAKE THE BYTE subscriber list available to other companies who wish to send our subscribers material about their products. We take great care to screen these companies, choosing only those who are reputable, and whose products, services, or information we feel would be of interest to you. Direct mail is an efficient medium for presenting the latest personal computer goods and services to our subscribers.

Many BYTE subscribers appreciate this controlled use of our mailing list, and look forward to finding information of interest to them in the mail. Used are our subscribers' names and addresses only (no other information we may have is ever given).

While we believe the distribution of this information is of benefit to our subscribers, we firmly respect the wishes of any subscriber who does not want to receive such promotional literature. Should you wish to restrict the use of your name, simply send your request to the following address.

BYTE MAGAZINE
ATTN: SUBSCRIBER SERVICE
P.O. Box 7643
TEANECK, NJ 07666-9866



Share your laser with Buffalo!

All ten ports are user configurable as either an input or output so you can build your own peripheral sharing network with the Buffalo SL.™



FAST: can run your PC at 19,200 baud

AFFORDABLE: \$500 plus

EXPANDABLE: from 0 - 4MB buffer

FLEXIBLE: 6 serial, 4 parallel ports

POP-UP MENU: even over graphics

GUARANTEE: 45 day money back

BUFFALO®

The inexpensive peripheral sharing solution

(800) 345-2356

Buffalo Products, 2805 19th Street SE, Salem, OR 97302 (503) 585-3414

Circle 56 on Reader Service Card

Take any 3 books for only \$1⁰⁰ each

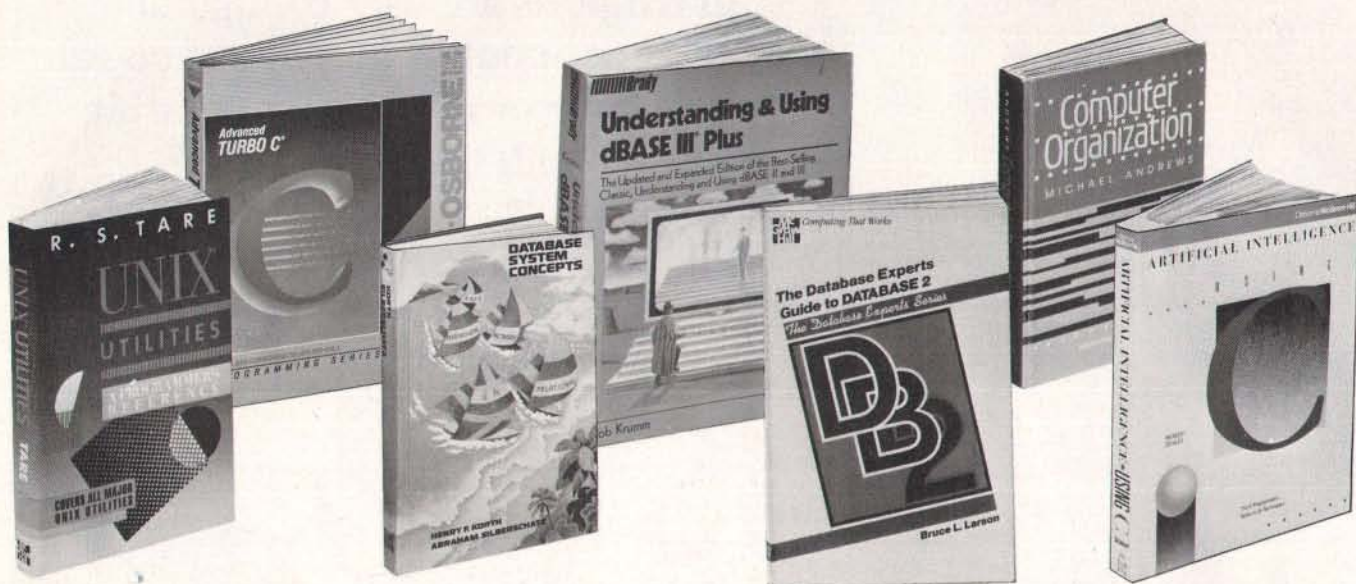

UNDERSTANDING & USING dBASE III[®] PLUS. By R. Krumm, 674 pp., illus., softbound. Widely regarded as the most comprehensive one-volume reference on the subject, it covers everything from basic concepts to advanced programming techniques.
583940-7 Pub. Pr., \$22.95

UNIX UTILITIES. By R.S. Tare. 352 pp., illus., softbound. This practical manual shows how to make the best use of UNIX utilities. It covers more utilities than any other book of its kind and provides numerous examples of real applications.
628/84X Pub. Pr., \$24.95

VSAM: Performance, Design, and Fine Tuning. By J. Ranade. 280 pp., illus. Find out how to adapt VSAM to your particular needs and cut processing time in half! This new work by an authority on VSAM provides the detailed, hands-on assistance you need to design and implement efficient systems.
583963-6 Pub. Pr., \$34.95

TURBO PASCAL PROGRAMMER'S LIBRARY. By K. Jamsa and S. Name-roff. 495 pp., illus., softbound. An outstanding and varied collection of more than 200 routines that you can quickly key into any computer that runs under PC-DOS. Includes some vital math functions not provided in Turbo Pascal's standard package.
583762-5 Pub. Pr., \$18.95

ADVANCED GRAPHICS IN C: Programming and Techniques. By N. Johnson. 430 pp., illus., softbound. Now C programmers can write crisp graphics programs for the IBM-PC using the IBM EGA (Enhanced Graphics Adaptor) or the AT&T Image Capture Board (ICB). Includes GRAPHIQ, a complete C graphics toolkit.
881257-7 Pub. Pr., \$22.95

when you join BYTE Book Club[®] Values up to \$135.95

- Your one source for computer books from over 100 different publishers
- the latest and best information in your field
- discounts of up to 40% off publishers' list prices

A COMPREHENSIVE GUIDE TO AI AND EXPERT SYSTEMS: Turbo Pascal Edition. By R.I. Levine, D.E. Drang, and B. Edelson. 256 pp., 99 illus. A must for everyone who wants to understand and utilize artificial intelligence for commercial, military, scientific, or educational applications. It's all in clear, simple language with many illustrations and sample programs.
374/708 Pub. Pr., \$22.95

32-BIT MICROPROCESSORS. Edited by H.J. Mitchell. 248 pp., 104 illus. and tables. A comprehensive survey of the powerful new microprocessors for large, technically complex projects. Coverage includes: AT&T's WE32100, Immos T414 and T424, Intel's 80386, Motorola's 68020, and Zilog's Z80000.
425/85X Pub. Pr., \$45.00

CIARCIA'S CIRCUIT CELLAR, Volume VI. By S. Ciarcia. 224 pp., 75 illus., softbound. More marvelous projects from the incomparable Ciarcia! This new volume contains easy-to-follow plans for a home security system, a serial Eprom programmer, a turnkey bulletin board, an audio-and-video multiplexer, plus 10 more projects.
109/680 Pub. Pr., \$19.95

PROGRAMMER'S CHALLENGE: 50 Challenging Problems to Test Your Programming Skills. By S. Chen. 464 pp. If you enjoy testing your programming skills, then you'll enjoy solving these 50 challenging problems. Solutions are provided in BASIC, Pascal, and C with full explanations and test data.
583883-4 Pub. Pr., \$29.95

ADVANCED TURBO C.[®] By H. Schildt. 397 pp., illus., softbound. Complete Turbo C mastery can be yours—from stacks, queues, linked lists and binary trees, to operating system interfacing, porting, debugging, and much more. Fully explains how to get the most from the power and speed of Turbo C.
881280-1 Pub. Pr., \$22.95

DATABASE SYSTEM CONCEPTS. By H. F. Korth and A. Silberschatz. 546 pp., illus. From fundamental concepts to advanced problem solving, this book provides a clear understanding of the design and use of database systems. Also demonstrates the best ways to protect data from unauthorized access and malicious or accidental alteration or destruction.
447/527 Pub. Pr., \$42.95

ARTIFICIAL INTELLIGENCE USING C: The C Programmer's Guide to AI Techniques. By H. Schildt. 412 pp., 37 illus., softbound. This hands-on guide shows you how to create your own AI applications and systems using C. After an introductory overview it provides coverage of expert systems, logic, natural language processing, machine learning, pattern recognition, and more, with ready-to-run programs illustrating each topic.
881255-0 Pub. Pr., \$21.95

PROGRAMMING USING THE C LANGUAGE. By R.C. Hutchison and S.B. Just. 519 pp., illus. Whether you want to understand programs in C written by others, or write better C programs of your own, this practical, authoritative book gives you the tools and guidance you need. Coverage includes program organization, sorting algorithms, recursion, linked lists, and more — with many sample programs.
315/418 Pub. Pr., \$28.95

HARD DISK MANAGEMENT with MS-DOS and PC-DOS. By D. Gookin and A. Townsend. 307 pp., illus. Shows you how to make the best use of your hard disk for all types of programs, with an emphasis on organization, data security, and enhancing performance. Easy enough for novices, yet sophisticated enough for power users, it's packed with helpful hints, proven shortcuts, and clear explanations.
583954-7 Pub. Pr., \$26.95

TRICKS OF THE UNIX MASTERS. By R.G. Sage. pp. illus. Many of UNIX's most interesting features have virtually been kept secret from users — until now! This master guide goes beyond the basics to show you the shortcuts, tools, tips, and tricks it could take years to discover on your own.
584637-3 Pub. Pr., \$22.95

SADT: Structured Analysis and Design Technique. By D. Marca and C. McGowan.
402/353 Pub. Pr., \$44.95

PROGRAMMING WITH TURBO PASCAL. By D. Carroll
852908-5 Pub. Pr., \$39.95

HIGH-SPEED ANIMATION & SIMULATION FOR MICROCOMPUTERS. By L. Adams
583855-9 Pub. Pr., \$19.95

DATABASE MACHINES & DATABASE MANAGEMENT. By E. Ozkarahan
583770-6B Pub. Pr., \$53.00
(Counts as 2 of your 3 books)

PRINCIPLES OF PARALLEL AND MULTI-PROCESSING. By G.R. Desrochers.
165/793 Pub. Pr., \$49.50
(Counts as 2 of your 3 books)

GETTING THE MOST FROM UTILITIES ON THE IBM PC. By R. Krumm
583790-0 Pub. Pr., \$19.95

THE ADA PRIMER. By P. I. Johnson
326/266 Pub. Pr., \$17.95

THE DATABASE EXPERTS' GUIDE TO DATABASE 2. By B. Larson.
232/679 Pub. Pr., \$34.95

NETWORKING SOFTWARE. By C. B. Ungaro.
606969-9 Pub. Pr., \$37.95

THE DATABASE EXPERT'S GUIDE TO SQL. By F. Lusardi
390/061 Pub. Pr., \$39.95

PRINCIPLES OF ARTIFICIAL INTELLIGENCE AND EXPERT SYSTEMS DEVELOPMENT. By D.W. Rolston
536/147 Pub. Pr., \$39.95

HOW TO WRITE COMPUTER DOCUMENTATION FOR USERS, 2nd Ed. By S.J. Grimm
583783-8 Pub. Pr., \$29.95

DATA STRUCTURES USING PASCAL, 2nd Ed. By A. M. Tenenbaum & M. J. Augenstein
583738-2 Pub. Pr., \$46.00

MICROCOMPUTER LANS: Network Design and Implementation. By M.F. Hordeski
584580-6 Pub. Pr., \$28.95

OPERATING SYSTEMS. By M. Milenkovic
419/205 Pub. Pr., \$40.95

HYPERTALK PROGRAMMING. By D. Shafer.
584653-5 Pub. Pr., \$24.95



Any 3 books for \$1.00 each... if you join now and agree to purchase three more books — at handsome discounts — during your first year of membership.

COMPUTER ORGANIZATION. By M. Andrews.
584588-1 Pub. Pr., \$39.95

DEBUGGING TECHNIQUES FOR IBM PC BASIC. By J. R. Corsi & W. F. Hills
583693-9 Pub. Pr., \$17.95

CIARCIA'S CIRCUIT CELLAR, Volume V. By S. Ciarcia
109/672 Pub. Pr., \$21.95

HANDBOOK OF SOFTWARE MAINTENANCE. By G. Parikh
583639-4 Pub. Pr., \$35.95

THE C PRIMER, 2nd Ed. By L. Hancock & M. Krieger
259/95X Pub. Pr., \$22.95

DATA TYPES AND DATA STRUCTURES. By J. J. Martin
583689-0 Pub. Pr., \$44.67

TROUBLESHOOTING AND REPAIRING THE NEW PERSONAL COMPUTERS. By A. Margolis.
583871-0 Pub. Pr., \$17.95

ADVANCED TURBO PASCAL: PROGRAMMING AND TECHNIQUES. By H. Schildt.
583761-7 Pub. Pr., \$18.95

SOFTWARE ENGINEERING: A PRACTITIONER'S APPROACH. By R.S. Pressman.
507/83XB Pub. Pr., \$47.95
(Counts as 2 of your 3 books)

68000 ASSEMBLY LANGUAGE PROGRAMMING, 2nd Ed. By L. Leventhal; D. Hawkins; G. Kane & W. Cramer
583817-6 Pub. Pr., \$28.95

ADVANCED COBOL, 2nd Ed. By A. S. Philippakis and L. J. Kazmier.
498/13X Pub. Pr., \$35.95

RECOMMENDED DIAGRAMMING STANDARDS. By J. Martin
583597-5 Pub. Pr., \$48.00
(Counts as 2 of your 3 books)

FILE ORGANIZATION FOR DATABASE DESIGN. By G. Wiederhold.
701/334 Pub. Pr., \$40.95

USING TURBO C. By H. Schildt
881279-8 Pub. Pr., \$19.95

More Books to Choose from

FOILING THE SYSTEM BREAKERS: COMPUTER SECURITY AND ACCESS CONTROL. By J. Lobel
383/57X Pub. Pr., \$37.50

IMS (DL/1) DATABASE ORGANIZATION AND PERFORMANCE. By G. Hubbard
583840-0 Pub. Pr., \$32.95

HOW TO BE A SUCCESSFUL COMPUTER CONSULTANT. By A. R. Simon
572/968 Pub. Pr., \$19.95

THE THEORY AND PRACTICE OF COMPILER WRITING. By J. P. Tremblay & P. G. Sorenson
651/612B Pub. Pr., \$46.95
(Counts as 2 of your 3 books)

INTRODUCING PC-DOS AND MS-DOS: A GUIDE FOR BEGINNING & ADVANCED USERS. By T. Sheldon
565/597 Pub. Pr., \$24.95

APPLYING EXPERT SYSTEMS IN BUSINESS. By D. N. Chorafas
108/803 Pub. Pr., \$31.95

STRUCTURED COBOL: A STEP BY STEP APPROACH. By C.R. Litecky and G.B. Davis.
157/88X Pub. Pr., \$30.95

TELECOMMUNICATIONS AND DATA COMMUNICATIONS FACTBOOK. By J. Abbatiello and R. Sarch
606965-6 Pub. Pr., \$39.95

DESIGN OF DISTRIBUTED OPERATING SYSTEMS. By P. J. Fortier
216/215 Pub. Pr., \$42.95

WORDPERFECT®: THE COMPLETE REFERENCE. By K. Acerson.
881312-3 Pub. Pr., \$27.95

HANDS-ON-BASIC: FOR THE IBM PERSONAL COMPUTER. By H. Peckham
491/78X Pub. Pr., \$26.95

Here's how Byte Book Club® works to serve you:

- **Important information... we make it easy to get!** Today, professionals who perform best are those who are best informed. For reliable, hands-on information, turn to the Byte Book Club. Every 3 or 4 weeks (12-15 times a year), members receive the Club Bulletin offering more than 30 books — the best, newest, most important books from all publishers.
- **Dependable service... we're here to help!** Whether you want information about a book or have a question about your membership, just call us toll-free or drop us a line. To get only the books you want, make your choice on the Reply Card and return it by the date specified. If you want the Main Selection, do nothing — it will be sent to you automatically. (A small shipping and handling charge is added to each shipment.)
- **Club convenience... we do the work!** You get a wide choice of books that

simply cannot be matched by any bookstore. And all your books are conveniently delivered right to your door. You also get 10 full days to decide whether you want the Main Selection. (If the Club Bulletin ever comes late and you receive a Main Selection you don't want, return it for credit at our expense.)

- **Substantial savings... and a bonus program too!** You enjoy substantial discounts — up to 40%! — on every book you buy. Plus, you're automatically eligible for our Bonus Book Plan which allows you savings up to 70% on a wide selection of books.
- **Easy membership terms... it's worthwhile to belong!** Your only obligation is to purchase 3 more books — at handsome discounts — during the next 12 months, after which you enjoy the benefits of membership with no further obligation. You or the Club may cancel membership anytime thereafter.

Fill out the card and mail today! If the card is missing, write to:

BYTE BOOK CLUB®, P.O. Box 582, Hightstown, New Jersey 08520-9959
For faster service in enrolling, call 1-800-2-MCGRAW

Profax Verlagsges, Vienna • Technische Universität, Vienna • Banco Industrial de Peru • BOSCH, Gerlingen-Schillerho
 aimler Benz, Stuttgart • Saudi Eastern Petrochemical Company • Global Engineering Ltd. • Chulongkorn University, Tha
 Philippine Institute for Development Studies • J. Walter Thompson, Madrid • Institute for Information Industries, Taipei • EPFL, Switze
 AB Volvo • Universidade Nova De Lisboa • Instituto Superior Tecnico, Buenos Aires • UNESCO, Asian Pacific Headquart
 hulongkorn University, Thailand • Philippine
 ar East Broadcasting Corporation • AB Volvo •
 Saudi Eastern Petrochemical Company • King
 Kommunedata, Denmark • University of
 ngapore Polytechnic • Westinghouse • Jet
 Global Engineering Ltd., London • EPFL,
 Universität Stuttgart •
 niversity of
 oteborg •
 anco Indust
 ial de Peru
 BOSCH,
 erlingen-
 Schillerhohe
 Institute
 r Infor-
 ation
 ndustries,
 Taipei • The
 brary Cor-
 oration • AB
 olvo • Babcock
 nd Wilcox
 ational
 ark Service
 of the United
 ates • Tech-
 sche Universi-
 t, Vienna •
 Universidade Nova De Lisboa • Instituto Superior Tecnico, Buenos Aires • UNESCO, Asian Pacific Headqua
 Universidad de Ingenieria, Lima • Institute for Information Industries, Taipei • Eurotax Verlagsges, Vienna • Daimler Benz, Stuttg
 ng Fahad University of Petroleum and Minerals • Jet Propulsion Laboratories, Pasadena • Westinghouse • Ciba Geigy, I



• Technische Universität, Vienna •
 • Saudi Eastern Petrochemical Company •

Jardine Matheson
 Taiwan Ltd. • Tec
 College of Stavang
 Farmer's Bank of Sw
 • Norwegian Direct
 of Telecommunicatio
 The United States Pent
 • Daimler Benz, Stuttg
 Univers
 de Ingeni
 Lima • I
 Airlines • S
 Eastern P
 chemical C
 pany • G
 Engineering
 • Chulong
 University, Thaila
 • Eurotax Verlag
 Vienna • Philippine Ins
 for Development Studi
 • J. Walter Thompson, Mac

Why do institutions worldwide trust ARC? Before you purchase your next computer, call us. You owe it to yourself to find out.

					ARC American Research Corporation			
(2) 633500	274-8350	967211	(40) 660051	(1) 442-7154				
								
(1) 687699	(2) 852-0232	2421812	(52) 609-100	(2) 396-9900		562459	257-581	(213) 265-0843
								
(22) 825575	(222) 934212	1681169	(31) 658551	(3403) 90911	(2) 402391	(2) 251-7078	(1) 684-4144	
								
(42) 12560	3826-5007	128-68481	(14) 415-206	(21) 380-2717	(3) 798-2663	297-475	574980	



OS/2's MULTITASKING DASHBOARD

You can fine-tune OS/2's CONFIG.SYS file to give optimum performance for your particular setup

One of OS/2's two big draws is multitasking. (The other, of course, is large memory.) Multitasking is a bit of processor sleight of hand that makes a single piece of silicon seem to do more than one thing at the same time.

At first blush, this seems simple: If you have n programs in the computer, just give each program a small amount of CPU time, called a *time slice*. Program 1 gets 10 milliseconds, program 2 gets 10 ms, and so on. How tough could that possibly be?

That approach isn't tough at all. But it's also inadequate for communications programs, as they can't afford to be totally inactive for a number of time slices. It's also inefficient for I/O-bound programs, since they may end up getting an entire time slice in which all they do is wait for a keystroke.

Everyone Is a Systems Programmer

Any decent multitasker—and OS/2 falls into that category—goes beyond simple time slicing. But beyond simple time slicing, there be dragons. There's no best way to multitask, so multitasking operating systems have a wealth of *tuning parameters*, variables you adjust to get maximum performance. In the DOS world, the `buffers=` variable is one example of a tuning parameter.

The names of some new multitasking parameters are `priority`, `timeslice`, and `maxwait`. Such tuning parameters are important in multitaskers. For example, when I used to work in a large IBM-

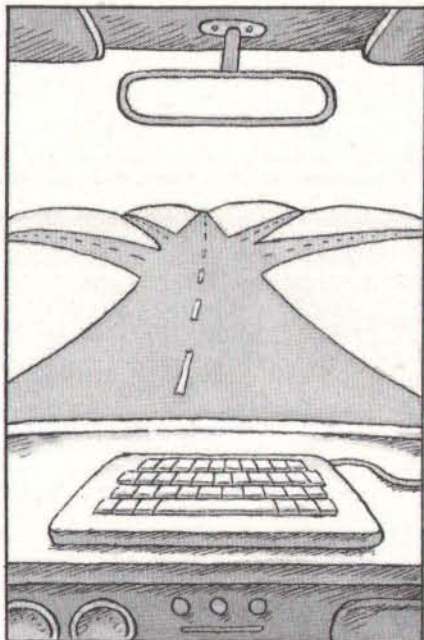

mainframe-based DP shop, users would periodically learn that on such and such a day the system would be upgraded by the addition of more or better processors, I/O processors, or the like.

"Great," we'd say, as this would no doubt improve response time. But the day after the installation, response time would stink. Why? Because the system hadn't been tuned. There's a whole cadre of people at mainframe shops whose jobs revolve around adjusting the tuning parameters of the system to get maximum throughput: They're called systems programmers.

The other day, I had a conversation with the president of a well-known database company while flying to California (there's something strange about this, but 50 percent of the people I meet on planes seem to be in the computer business, and I do a lot of flying). He complained, "OS/2 sounds good, but I'm afraid it's going to force me to become a systems programmer in my spare time to

get anything out of it."

There's no getting around it: You'll have to fool around with OS/2's multitasking parameters a bit. But here are a few results and some insight into getting the most out of OS/2 multitasking.

Schizophrenic Slicing: The Priority Parameter

Reviews of OS/2 often discuss the "OS/2 scheduling algorithm," as if there were just one. In fact, OS/2 has two algorithms. You select one or the other with the `priority=` variable in the CONFIG.SYS file. The legal values for this are `absolute`, an egalitarian algorithm, and `dynamic`, a foreground-selfish algorithm.

`Absolute` is pretty straightforward. I wrote a test program called `TIME1` that does simple computations over and over again. It does no I/O except for a final performance report, so it is a compute-bound program. Then I ran eight copies of `TIME1`, one in the foreground and seven in the background. The programs report how many computations they got done per second. The results are shown in table 1.

Note that all tasks get equal time. The foreground doesn't get any special treatment. But if you do the same run with `priority=dynamic` in the CONFIG.SYS file, as shown in table 2, you'll see quite a difference. The dynamic algorithm gives a much greater share of the CPU's attention to the foreground than to the background.

Microsoft included the dynamic option (in fact, it's the default value for `priority=`) as part of what Gordon Letwin, the architect of OS/2, calls the "OS/2 religion." In traditional minicomputer and mainframe systems, he argues, the desire is to make each user seem to get a fair share of CPU attention. Under OS/2, however, we have a multitasking operating system without multiple users. In this case, we're not concerned with

continued

90% of the world are still waiting. What the hell are those importers doing?

Printer Buffer inside cable.

For the average user, most buffers are too complicated. So we designed a buffered cable with 64K or 256K inside.

Just a cable. As easy to use. Nearly as inexpensive.

**Battery-operated data buffer**

Up to 128K with parallel or RS232-input, will hold data for as long as 3 years. Record and play as often as you like. Carry data to a printer or to another computer.

**Share your printer.**

Forget these boxes that occupy a lot of your desk space. Forget the times when you had to switch manually. We have a cable that allows two computers to share one printer automatically.

**That's what T-switches should look like!**

For IBM-compatibles. 2 printers to one computer. Complete set incl. all cables and a small switch-box. **Just a cable.** No bulky box.

**Isolating line drivers**

If a line driver is not optically isolating, you might face problems arising from different mains supplies. That's why our RS232-drivers are 100% isolated up to 1,000 volts.

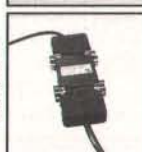
**Data isolators**

Transients on the mains supply or electrostatical discharges can cause erroneous data transmissions and even destruction of computers. We offer optical isolators up to 50kV.

**Terminal bus.**

Connect up to 16 terminals to one 2-wire bus. Save installation costs and gain flexibility and ease of use. Terminal-Bus-Adaptors includes 1kV optically isolated line drivers.

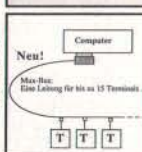
**Interfaces.**

We have a complete line of interfaces: 20mA, Atari130, C64/128, Centronics, IEEE488, RS232, RS422, RS423 and RS485. (The following are registered trademarks: Atari, C64, C128, Centronics, IBM)



Austria:	Basic, Wien	0222-9505410
Denmark:	Jatec, Spentrup	06-479139
France:	Neol, Strasbourg	(88) 623752
Singapore:	Overseas Trade	733-4577
Switzerland:	Weber&Co, Zürich	01-9302003
USA:	Tectrans, L.A.	(818) 2853121

Manufacturer and Exporter:

wiesemann & theis gmbh
MIKROCOMPUTERTECHNIK



winchenbachstr. 3-5 phone: ++ 49-202-505077
d-5600 wuppertal 2 telex: 859 16 56
west-germany fax: ++49-202-511050

Table 1: The results of TIME1, a simple compute-bound program run under OS/2. Eight copies of the program were run as simultaneous tasks, one in the foreground and seven in the background. The figures are the number of computations each copy performed per second. Note that all tasks got equal time.

Task name	Computations/sec
Foreground	280
Background 1	279
Background 2	279
Background 3	279
Background 4	279
Background 5	279
Background 6	279
Background 7	279

Table 2: The results when the test in table 1 is repeated with priority=dynamic in the CONFIG.SYS file. The foreground task now receives a much greater share of the CPU's attention.

Task name	Computations/sec
Foreground	1338
Background 1	142
Background 2	140
Background 3	141
Background 4	141
Background 5	142
Background 6	141
Background 7	67

giving a fair shake to each program. Instead, we're interested in giving the lion's share of the CPU time to the foreground program—the one the user is interacting with at the moment.

Minute by Minute: Timeslice

The OS/2 command timeslice appears in the CONFIG.SYS file as

```
timeslice =
<maximum><,minimum>
```

where the minimum is optional and the maximum must be at least 32 ms, the resolution of the OS/2 clock (length of one timer tick). The ticks of the timer tell OS/2 that it's time to stop doing whatever it's doing and consider switching to another program.

What's a good value for timeslice? That depends on what you're doing.

Think of it this way. Suppose I have two projects to work on at the same time. I could work on project 1 for 6 months, then project 2 for 6 months. This would work, but the client for project 2 might get a bit antsy knowing that I'm working only on project 1 for 6 months.

It's the same thing with OS/2. If I set timeslice to, say, 30,000 (30 seconds), OS/2 seems very balky. When it is paying attention to the foreground task, the system seems quick. But then it seems to die for a few minutes, as it devotes a few time slices to the background programs. The length of the time slice causes the choppy behavior. So, time slices can be too large.

Returning to my two projects, suppose I try the opposite approach. I'll spend a minute on project 1, then a minute on project 2, then a minute on project 1, and so on. Won't this seem a lot smoother to my clients?

No, again. The reason: It takes time to switch from one task to another. I've got to stuff whatever I'm doing on project 1 into a folder, then find the folder for project 2 and put the things from that onto my desk. That process may take 10 minutes. That implies that I work for a minute, switch tasks for 10 minutes, work for a minute, switch for another 10 minutes... you get the idea. Notice that the switching time has no relation to the size of the time slice. If I switched only every 6 months, I'd still require only 10 minutes.

So time slices are like the beds Goldilocks found: There's "too hard," "too soft," and "just right." For strictly CPU-bound programs, a larger time slice (about 1/2 second) is good. For communications programs, which can't afford to be out of commission for long, small time slices are good. Unfortunately, you just can't adjust timeslice= on the fly. You must change your CONFIG.SYS file, then reboot—what a pain.

To demonstrate the effect of timeslice=, I ran my CPU-bound TIME1 loop program in the foreground and in the background simultaneously. I ran it for different time slices, with values ranging from 32 ms to 8 seconds. The results, which are found in table 3, show the range of good time slices, but they also seem to point to some strangeness in the OS/2 priority=dynamic scheduling algorithm, as I'll explain.

Multitasking systems are stochastic, so rerunning the benchmarks could yield a completely different set of results. The numbers seem to show that a time slice in the range from 1024 ms to 4096 ms

continued

VNS America Corp.

delivers unmatched Quality, Performance
and Pricing!

COMPARE!

A Complete 12 MHZ High-Speed SIVA 286
System with 40MB (28MS-ST251-1) Hard Disk **\$1295**

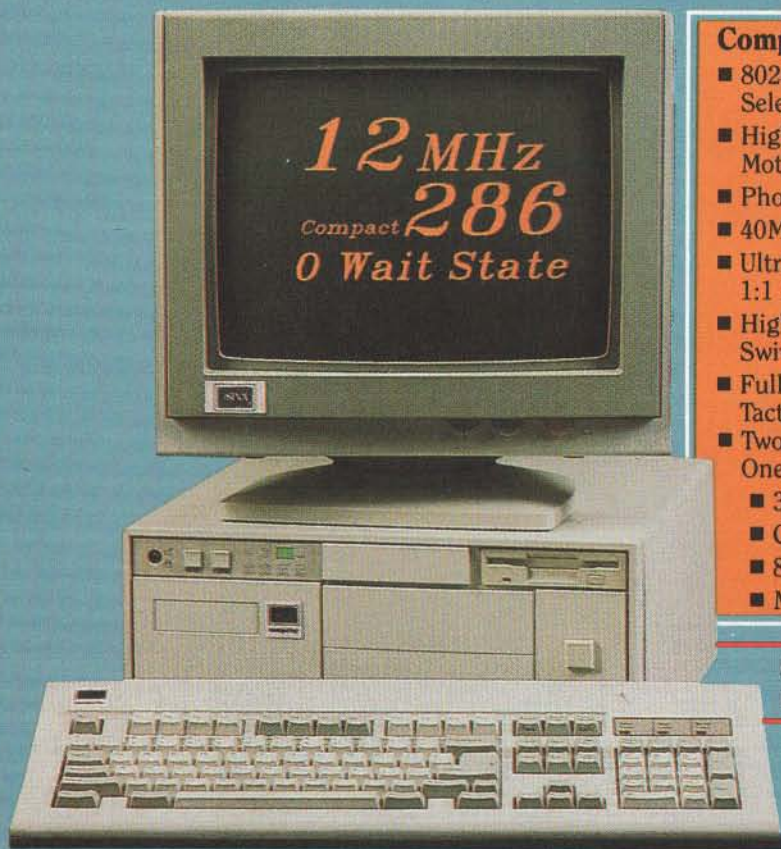

Complete System Features:

- 80286 CPU, 8/12.5 MHZ Dual Speed, Keyboard Selectable
- High-Speed RAM, 512K Expandable to 4MB on the Motherboard (16MB System Total)
- Phoenix BIOS
- 40MB Hard Drive, 1.2MB Floppy Drive
- Ultra High-Speed Floppy, Hard Disk Controller 1:1 Interleave, 800KB/Sec Transfer Rate
- High Resolution 12" Amber Display with Tilt and Swivel Base, with Compatible Graphics Controller
- Full 101-Key Enhanced Keyboard, Pleasant Tactile/Click Feel
- Two Serial and One Parallel Printer Ports and One Mouse Port
 - 3-16 Bit and 1-8 Bit Free Expansion Slots
 - Clock Calendar with 10-Year Life Battery Backup
 - 80287 Support, up to 12 MHZ
 - Meets FCC Requirements

Standard System Including all Standard Features except Hard Disk \$995

Lowest Cost Compilable Upgrades

- Additional 512K Memory for \$195.
- 1.5MB Additional Memory for \$395.
- EGA Upgrade for \$195.

Nine Reasons to Call VNS America Now...

- Produced by High Technology Manufacturing Processes
- Fully Surface Mounted Technology
- EGA Controller Standard
- Supports 3.5" and 5.25" Floppy Disks
- 10-Year Battery Life
- Phoenix BIOS
- No Memory Surcharge (We're not opportunists!)
- Same Day Shipment (Competitors often take 4-6 weeks.)
- 100%-Compatible with Your Budget

VNS America Corp.

Suite 270, 910 Boston Post Road
Marlboro, Massachusetts 01752 U.S.A.
1-800-252-4212
In Massachusetts 508-481-4746
FAX: 508-481-2218

**Order Now
Toll-Free**

1-800-252-4212

Spot the Top Dot.



Epson® LQ-2500

Toshiba P351SA

Advanced Matrix Technology
ACCEL-500
AMT Accel-500™

And we'll ship it to you **FREE** for 30 days.

The bad news is, this is a quiz. The good news is, we're going to make it easy.

All three of these 24-pin dot matrix printers are versatile, rugged office-quality printers. They all provide a variety of type styles and compatibility with most popular software. But there's only one Top Dot. And all the clues you need to find it are right here in this ad.

Top Dot's high performance features include combined letter-

quality text and graphics, color printing, and a sizzling 480 cps draft speed.



SelectDial puts total printer control at your fingertips.

A unique Select-Dial™ feature gives Top Dot effortless, fingertip control. And plug-in Intelli-Cards™ provide instant software upgrades.

Top Dot's \$1085 price is a remarkable \$400 below comparable printers. Even more remarkably, it includes toll-free hotline support, a 2-year warranty, an unheard-of full year of on-site service, and for \$25, a Quick-Start kit packed with \$150 worth of supplies, software, documentation and more.

And only Top Dot is available in your choice of finish: Executive Black or traditional Ivory.

You have to visit a dealer to buy two of the printers on this page. But you can get Top Dot delivered to your door by UPS.[®]

Just call 1-800-637-7878, correctly identify the Top Dot, and

COMPARISON CHART			
	AMT Accel-500	Epson LQ-2500	Toshiba P351SX
Print speed (12cpi)			
Draft Mode	480 cps	324 cps	300 cps
Memo Mode	200 cps	N/A	N/A
LQ Mode	80 cps	90 cps	100 cps
Plug-in fonts	card	card	cartridge
Color printing	standard	N/A	optional †
Warranty	24 mo	18 mo	18 mo
On-site service	1 yr	N/A	N/A
Price	\$1085	\$1449 ††	\$1499 ††
Starter Kit	\$25	N/A	N/A

\$239 †† manufacturer's suggested list price

we'll ship it to you. FREE.* If after 30 days, the Top Dot hasn't become indispensable to your office, just send it back. Otherwise, do nothing. We'll charge \$1085 to your credit card or bill you against your purchase order. That's all there is to it.

And if you're still not sure of the answer, don't worry. Our operators will give you three chances to get it right.



Quick-Start Kit contains supplies, cable, software, documentation—even transparency materials. A \$150 value for only \$25 with Top Dot.

ACCEL-500™

1-800-637-7878



Ventura Peripherals
100 Rancho Road, Suite 27
Thousand Oaks, California 91362

* Offer subject to availability and credit approval.

Table 3: The results of the TIME1 test, run with two simultaneous copies, one in the foreground and one in the background. The figures are the number of computations performed per second with the timeslice parameter set from 32 ms to 8 seconds. Note that, in this case, the foreground task receives the most CPU attention with timeslice set to less than 512 ms (½ second).

Time slice (ms)	Foreground computations/sec	Background computations/sec	Total computations/sec
32	2134	86	2220
256	1622	642	2264
512	1660	648	2308
1024	1245	1246	2491
2048	1170	1213	2383
4096	1477	1181	2658
8192	1022	1295	2317

yields the best total system throughput. Given the choice, though, you should take a smaller time slice. Sometimes a larger time slice leads OS/2 to put all the background jobs on hold until the foreground task is done. But the strange part is how the allocation of time shifts from foreground to background. It seems that as the time slice gets larger, the background priority gets higher. I haven't yet figured out why this is so, but I'll let you know as soon as I do.

How Long Must I Wait?: The Maxwait Parameter

Programs in OS/2 are assigned different priorities. Higher-priority programs generally get all the CPU's time, causing lower-priority programs to suffer from "CPU starvation." The priority=dynamic algorithm amends this by watching how long each program has been CPU-starved. After a certain number of seconds, the CPU-starved program's priority is nudged up a bit.

This still may not be enough to get it any CPU time, so even more seconds later the program's priority is nudged up again. This process continues until the program actually gets CPU attention for a single time slice; then its priority is returned to its original low level. The whole thing then starts over, as the program makes a slow climb up the priority ladder.

The maxwait parameter controls the above procedure. The command looks like

maxwait = <number of seconds>

You include this line, like priority and timeslice, in the CONFIG.SYS file. The system nudges up the priority of CPU-starved programs every maxwait seconds. For example, say it takes four

nudges to give a program sufficient priority to get some CPU time. The program ends up getting a time slice every 4 × maxwait seconds. If maxwait equals 1, the program gets a time slice every 4 seconds. If maxwait equals 10, the program gets a time slice only every 40 seconds.

It would be nice if we could assign a different maxwait for every program, but we can't. There is just one global system maxwait value.

This command is most important for keeping background processes alive. When priority=dynamic, recall that the background processes drop in priority. With a large value of maxwait, the background performance drops markedly. Of course, with priority=absolute, maxwait has no effect.

My Settings

OS/2's three new CONFIG.SYS commands—priority, timeslice, and maxwait—will all have a significant effect on your system's performance. Of the two priority options, priority=dynamic is the more interesting. I set my timeslice to 512 (½ second), which for me is a compromise between choppy switching and excessive overhead. I don't do OS/2 communications much—all my favorite communications programs still require DOS—but when I do, I'll no doubt have to drop this value. I leave maxwait at 1, or else nothing gets done in the background. ■

Mark Minasi is a managing partner at Moulton, Minasi & Company, a Columbia, Maryland, firm specializing in technical seminars. He can be reached on BIX as "mjminasi."

Your questions and comments are welcome. Write to: Editor, BYTE, One Phoenix Mill Lane, Peterborough, NH 03458.

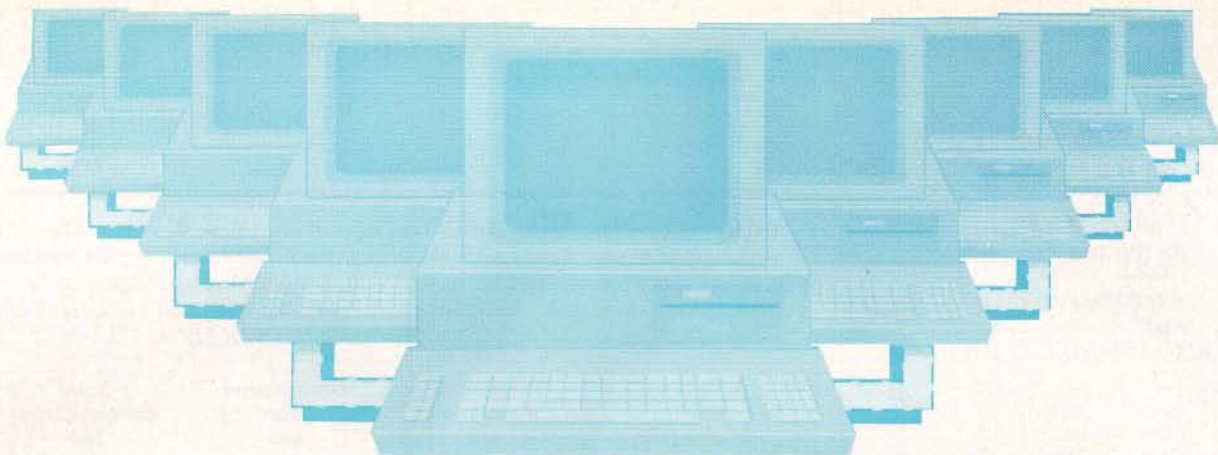

Tomorrow's LAN Solutions – Today.

EtherLAN Plus™/The Affordable Ethernet Solution

In today's LAN world, every new LAN manufacturer seems to have a new idea of what a network should be. Standards for the industry are few and far between, but are there if you want to pay for them. Wouldn't it be nice if for once you could buy a LAN system, at a price you can afford, and be fully compatible with the ethernet standard? Well now you can!

Turn Key Ethernet

EtherLAN is here to give you everything you need to set up an ethernet LAN system. You'll receive the EtherLAN network adapter, 25 feet of thinwire ethernet coax cable, T connector and easy to understand Installation and User's Guides, all for one low price. In addition to this, you'll also receive complete software needed to get your new EtherLAN system up and running quickly. You'll get NETBIOS software and also a complete network operating system to make using your new EtherLAN system even easier.

SimpleWARE™ Makes EtherLAN Unbeatable

The operating system you'll get works as a shell above DOS, so all your normal DOS programs will run on EtherLAN as well as locally.

Even better yet, you can use standard DOS commands to control your network, so you are not stuck spending hours to learn a new set of commands. The operating system functions transparently, so you won't even know you're on a network.

Features You Can Rely On.

- Fully ethernet and cheapernet compatible (IEEE 802.3).
- Fast — a full 10,000,000 bit per second.

- Low memory requirements.
- NETBIOS compatible.
- Everything you need is included at one low price.

The best news of all is the price.

At only \$699.95 per node, you get all hardware, software, cabling and manuals needed.

Introductory Offer

Four Node Kit for only \$2499.00. Save over \$300.00.

EtherLAN 6 Node Comparison

500 Kbytes	Read and Write	Retail
EtherLAN	11 and 10 seconds	\$4199
3Com®	14 and 12 seconds	\$5670*
Novell SFT®	10 and 9 seconds	\$8265*

*Figures from PC Magazine.

- NO dedicated servers are required.
- Transparent operation —operates as a shell above DOS.
- Easy to use DOS type commands or pop up menus.
- Share disks, subdirectories, printers and plotters.
- DOS file and record locking.
- Up to 5 printers per server.
- Time and Date sharing.
- Electronic Message System.

With features like these, and an affordable price per node, how can you lose?

Call Toll Free
1-800-262-8010
1-714-529-8850 (in CA)



VISA, M/C, COD, or Prepaid orders accepted.



See us at COMDEX Booth #B1540
Simple Net Systems, Inc.

545 W. Lambert Rd., Suite A
Brea, CA 92621
FAX: (714) 529-2413

Requires IBM PC/XT/AT or compatible, running DOS 3.10 or higher. EtherLAN is a registered trademark of Simple Net Systems, Inc. Other brand and product names are trademarks of their respective holders.

YOU CAN'T GET THERE FROM HERE—OR CAN YOU?



The development of gateways could pave the way for a nationwide telecommunications network

“**Y**ou can't get there from here.” That's the classic comeback to the beleaguered traveler, and it usually draws a small, if weary, smile. But when you use that line in the context of the on-line community, people don't smile; they wince.

On-line networks are fractured and compartmentalized. It's a small miracle that anyone finds his or her way around. Yes, we have packet-switched networks, but these information highways resemble the state of America's highway system around the turn of the century (few signposts exist, and maps are confusing, if they exist at all) more than today's “state-of-the-art” superhighways.

The French solved this problem by installing a single information highway called Minitel. Minitel has become the world's standard on linking information services with the end user. For the French, it was a relatively easy solution. The phone system is a monopoly. One system serves the entire country, no questions asked. But such an environment doesn't exist in the U.S.

When Judge Harold Greene's Modified Final Judgment (MFJ) broke up Ma Bell's monopoly, thus creating the seven regional Bell operating companies (RBOCs), he put very rigid controls on what types of services the RBOCs could and couldn't provide. One constraint prohibited the so-called Baby Bells from providing “enhanced services, such as data networks that would allow links to

information providers.” This created a competitive environment wherein packet-switched networks could thrive.

But that environment changed radically last March, when Greene, during his triannual review of the MFJ, allowed the RBOCs the opportunity to create information highways, now called “gateways.”

Cutting the Ribbon

Judge Greene essentially “cut the ribbon” on these new highways by allowing the RBOCs to provide such capabilities as voice store and forward, protocol conversion, gateway services, electronic white pages, and information storage. He has allowed the RBOCs to participate in everything except the origination of information content. In essence, Greene's decision has laid the groundwork for a revolutionary information infrastructure.

Greene's action isn't a simple twist of free market ideology; his decision tosses a gauntlet at the feet of the RBOCs, challenging them to prove themselves.

You see, Greene is enamored of the French Minitel system. And he makes it no secret that he'd like to see something similar spring up throughout the U.S. He now wants to see just how much intelligence and market savvy the RBOCs really have. If they pass this test, if they create a viable market from within this gateway structure, he may at some point give the RBOCs much more freedom to compete in the information industry. But that's a big “if.” (And it raises disturbing questions better dealt with in another column.)

Making It Work

According to Robert Smith, president of the Videotex Information Association (VIA), the forthcoming gateways should contain the following characteristics:

- *Ease of use.* The gateways must be usable by novice or untrained users, as well as by expert users. The implication is

that gateways will need to offer a variety of navigation options to allow full access to novices while not being perceived as slow or cumbersome to experienced users.

- *Affordability.* The use of the gateways must not significantly raise the cost of using information services. Ideally, they should lower information costs.

- *Ubiquity.* For information services to be accessible to the widest audience possible, gateways must be implemented across the entire North American landscape, not merely in a limited number of markets.

- *Uniformity.* Gateways should have a standard “look and feel” so that users traveling from one location to another will not be required to learn new procedures for using the gateway. There must also be a gateway-to-gateway connection.

To the user, the gateway should appear as a directory. The directory would contain a series of menus listing each information provider connected to the gateway. Standards for these directories have yet to be hammered out, but it's widely recognized that they all should be uniform in appearance.

By dialing into the gateway, you'll have hundreds, perhaps thousands, of information services to choose from. You can search the directories by keyword. Once you've located your desired information service, the gateway will connect you directly to that service. This will eliminate the need to memorize the commands for several different networks.

According to the VIA, by the year 2000, the availability of gateways will have increased sufficiently so that travelers will be able to access their “primary gateway” via a simple, standardized interconnection procedure. Each gateway will be sufficiently compatible to include the ability to gather and store information about individual users. Each gateway will match the user's terminal and navigational preferences and establish a

continued

means of payment for use of the gateway and of services reached through it.

The Four Cs

Content is perhaps the most important issue when discussing gateways. John Gunter, a Bellsouth vice president, says that the aim of his company's Transtex Universal Gateway (TUG) market trial is to supply a "market basket" rich enough to draw a wide audience of users. The critical mix of this market basket is a host of localized information services.

Gunter identifies such local information services as hospitals, schools, local governments, social services, and even small businesses. Industry observers say that the success of gateways will depend on the RBOCs' ability to recruit such "nontraditional information providers." In this way, information services available on the local gateway will be relevant to the everyday lives of the people using the gateway. Such localized services might include ticket purchases for local entertainment establishments and on-line restaurant reservations.

The cost factor cuts three ways. First, the cost of accessing information ser-

vices is likely to drop. This should entice more people into using on-line information services. Costs will drop because, in most cases, users won't have to lay out subscription fees for several different services. Instead, they will pay a small fee for using the gateway to access those same services that once required costly subscriptions or minimum monthly usage fees. This will encourage more casual use of information services in a kind of "pay as you go" atmosphere.

Second, costs to the information providers themselves will drop. Currently, start-up costs for an information provider are prohibitive. This is due, in part, to capital investment in equipment, administrative overhead, and the costs of "hanging" that service on an existing packet-switched network. Because the RBOC gateways can store information, an information provider need supply only the information, not the equipment. Administrative functions, such as billing services, can be handled by the gateway, too. And the means of access is, of course, taken care of by tying into the established gateway. Most agree that the cost of "hanging" an information service

on a gateway will be substantially lower than a similar setup on a packet-switched network like Telenet.

When a mass market for information services starts to materialize, many of the costly information services in existence today will have to rethink their pricing structures. The current high cost of information is due to an extremely narrow market. However, as more users begin to access the gateways, information providers should be able to lower costs, making up in volume what they lose by lower prices.

As costs are lowered, more people will access the service. This could lead to even lower costs, owing to a higher volume of users. The same "domino effect" has occurred over the past 3 years with long-distance phone rates. As the total number of long-distance telephone calls rose dramatically, the FCC ordered rates cut in direct proportion to the high usage. Each time rates were cut, usage went up, and again the FCC ordered rate cuts.

The issue of coverage was summed up by Congressman John D. Dingall when he said, "A democratic society is at risk if it allows only an elite few to reap the

How the competition stands

Introducing the modem with a sleek new stand-up* design. Telebit's new T1000 Multi-Speed modem. The modem that not only looks different, but is different. With more features. More performance. And a surprisingly low price.

More modem for less money.

What makes the T1000 so different? For one, you get a choice of more speeds. The T1000 can send and receive data at 300, 1200, 2400, or 9600 bps using ordinary dial-up phone lines.

So the T1000 can talk to your installed base of low-speed modems, plus the large installed base of Telebit® and other PEP™ high-speed modems.

But it costs about the same as a

2400 bps error-free modem.

Another difference? The T1000 runs at 9600 bps with any type of data—without compression. Error free. With MNP and PEP error detection and correction.

The T1000 fits right in.

The T1000 Multi-Speed modem even talks Hayes—right from the box. And if you're using the AT command set or even Smartcom III software, we're compatible. You won't need new software. And you won't need new commands.

The T1000 also has internal support for the most widely-used communications protocols—Kermit, Xmodem, Ymodem and UNIX's UUCP. So you can transfer files up to 3 times faster than any other modem.

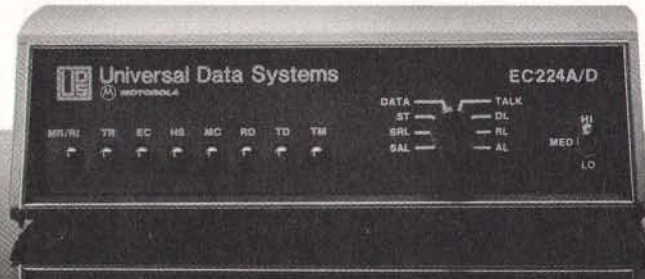

benefits of the information revolution." Ubiquitous coverage is the ultimate goal of these gateways.

Last May, Bellsouth Chairman John Clendenin gave a speech during the SuperComm trade show in which he said his fond vision is the development of telecommunications to "offer the most rural community in this nation the opportunity, via a gateway network, to be a viable player in the global information marketplace."

Conflicts

There is seldom any kind of innovation that does not fall prey to conflict. Gateways are no exception. For starters, established information services, such as CompuServe, have been very vocal in opposing gateway experiments. CompuServe is afraid that gateways will dilute its user base. On the contrary, with the likelihood of casual usage by potentially millions of users, CompuServe and services like it stand only to gain from being accessible via a gateway service. Indeed, after CompuServe lost its initial appeal to the FCC to have the gateway experiment squashed, it has now signed with at

least two different gateway projects.

Other conflicts came from newspapers, which fear a loss of classified advertising revenue. It's a healthy fear, because newspapers last year racked in some \$32 billion in classified ads alone, according to the Newspaper Advertising Bureau. The danger is that users might turn to on-line services where they can electronically search for services, rather than thumb through the daily newspaper. If the gateways are successful at recruiting local businesses, newspapers might well see a drop in ad revenues.

Packet-switched networks also stand to lose. With cost-effective rates offered by gateways, in addition to supplementary services such as billing and information storage, information providers could easily be seduced away from the packet-switched networks. However, because an information provider cannot directly connect to a gateway service outside of its own region (for example, a Boston company cannot directly connect to Pacific Bell's gateway), packet-switched networks can be used to bring the information provider to the "door" of a remote gateway service. This arrange-

ment will likely cause a shift in the role of packet-switched networks.

Looking Forward

Currently, three gateway experiments are under way, conducted by Bell Atlantic, Bellsouth, and NYNEX. At least two others, Pacific Bell and Ameritech, have gateways on the drawing board that should be ready for testing soon, if not already in use by press time.

Gateways, if successful, will change forever the way we think and interact with information services. If the RBOCs can truly create a ubiquitous information highway, they will create an environment of low-cost, easily accessible information that will eradicate today's information elite subset.

Now that's something to smile about. ■

Brock N. Meeks is a San Diego-based freelance writer who specializes in high technology. You can reach him on BIX as "brock."

Your questions and comments are welcome. Write to: Editor, BYTE, One Phoenix Mill Lane, Peterborough, NH 03458.

up to Telebit's newest modem.

And here's another big difference. Since the T1000 runs the most popular communications software at the highest possible speeds. You can take full advantage of packages like HyperACCESS, Crosstalk-Fast, MicroPhone II, and Acknowledge.

Just plug us in, and the T1000 will fit right in. No matter what your environment.

Remote management for ease of use.

Here's the final difference. The T1000 offers a host of remote management features. Including remote access, remote configuration and remote diagnostics.

So get the modem that's head and shoulders above the rest. In features and performance. At just the right price. Telebit's new

T1000 Multi-Speed Modem.

Call 1-800-TELEBIT or (415) 969-3800, today.

Or write Telebit at 1345 Shorebird Way, Mountain View, CA 94043-1329. Fax: (415) 969-8888.

Because no one gets the message through like Telebit.

T1000.



© 1988 Telebit Corporation. Telebit is a registered trademark and PEP is a trademark of Telebit Corporation. Other brands or product names are trademarks of their respective holders.

*optional

Circle 330 on Reader Service Card

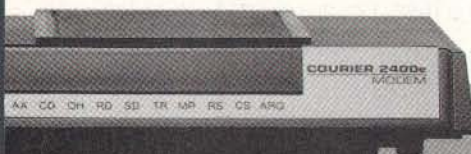

Intel announces

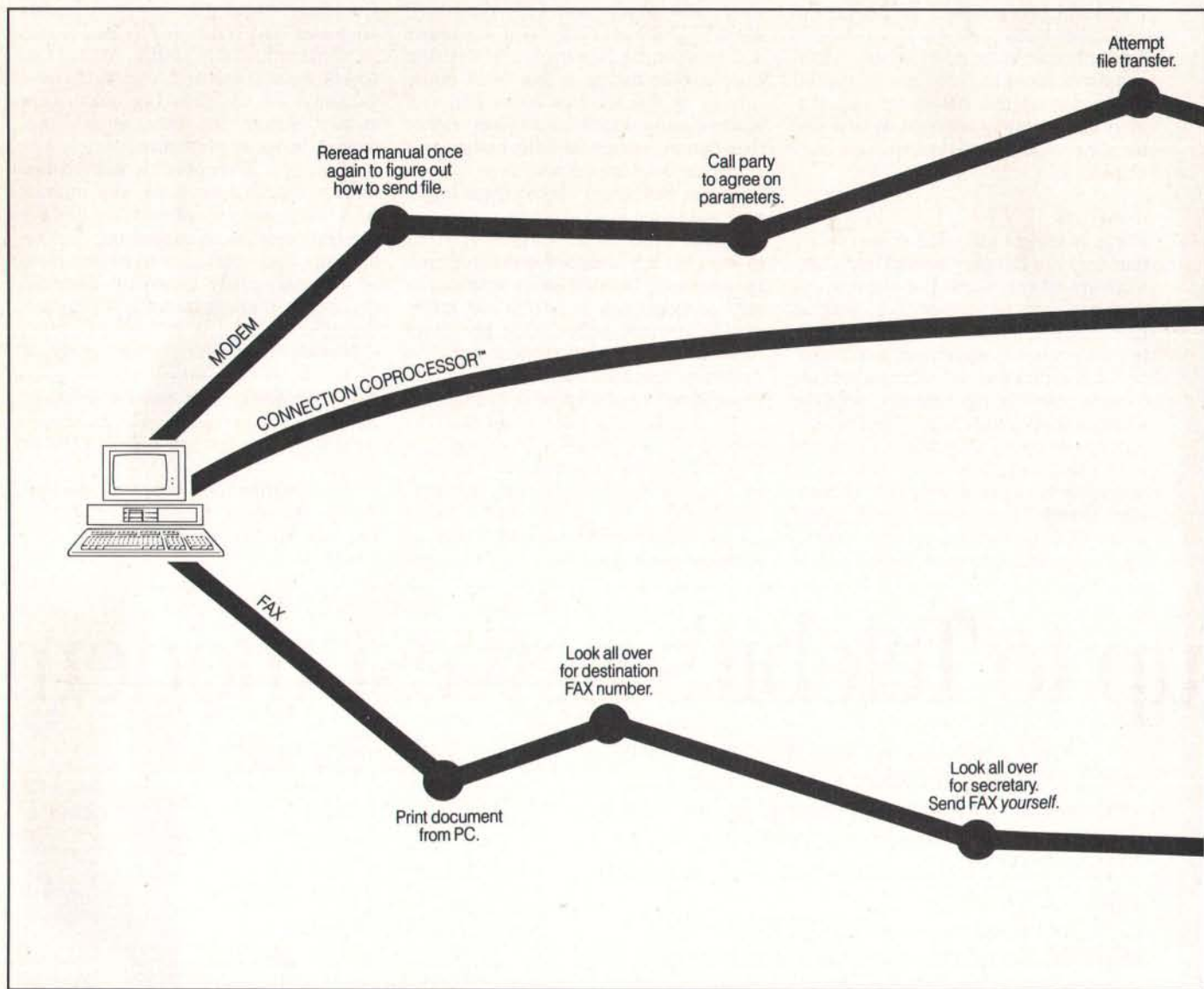

Announcing the first non-stop communications route between businesses anywhere in the world.

Intel's Connection CoProcessor.™

It's a whole new way to send and receive programs, files, text, graphics and electronic messages. Not just between PCs, but with fax machines as well.

The Intel Connection is a new communications coprocessing board that frees your PC from the task of communicating.

Which means you can work on your computer non-stop—even while

sending a document as big as the New York phone book.

Now your faxes or files can fly cross country. And you can still be zooming around in your flight simulator. Or writing that letter to your biggest account. Or recalculating your spreadsheets for tomorrow's meeting. Without interruption or downtime.

And when you fax, there are no more stopovers at the printer, or cooling your heels in line at the fax machine. Because Connection lets you do everything without leaving your PC. And when you send files directly to



©1988 Intel Corporation. Connection CoProcessor is a trademark of Intel Corporation. WordPerfect is a registered trademark of WordPerfect Corp. Ashton-Tate is a registered trademark of Ashton-Tate Corporation. Borland is a registered trademark of Microsoft Corporation. *CAS (DCA/Intel Communicating Application Specification.)

non-stop flights.

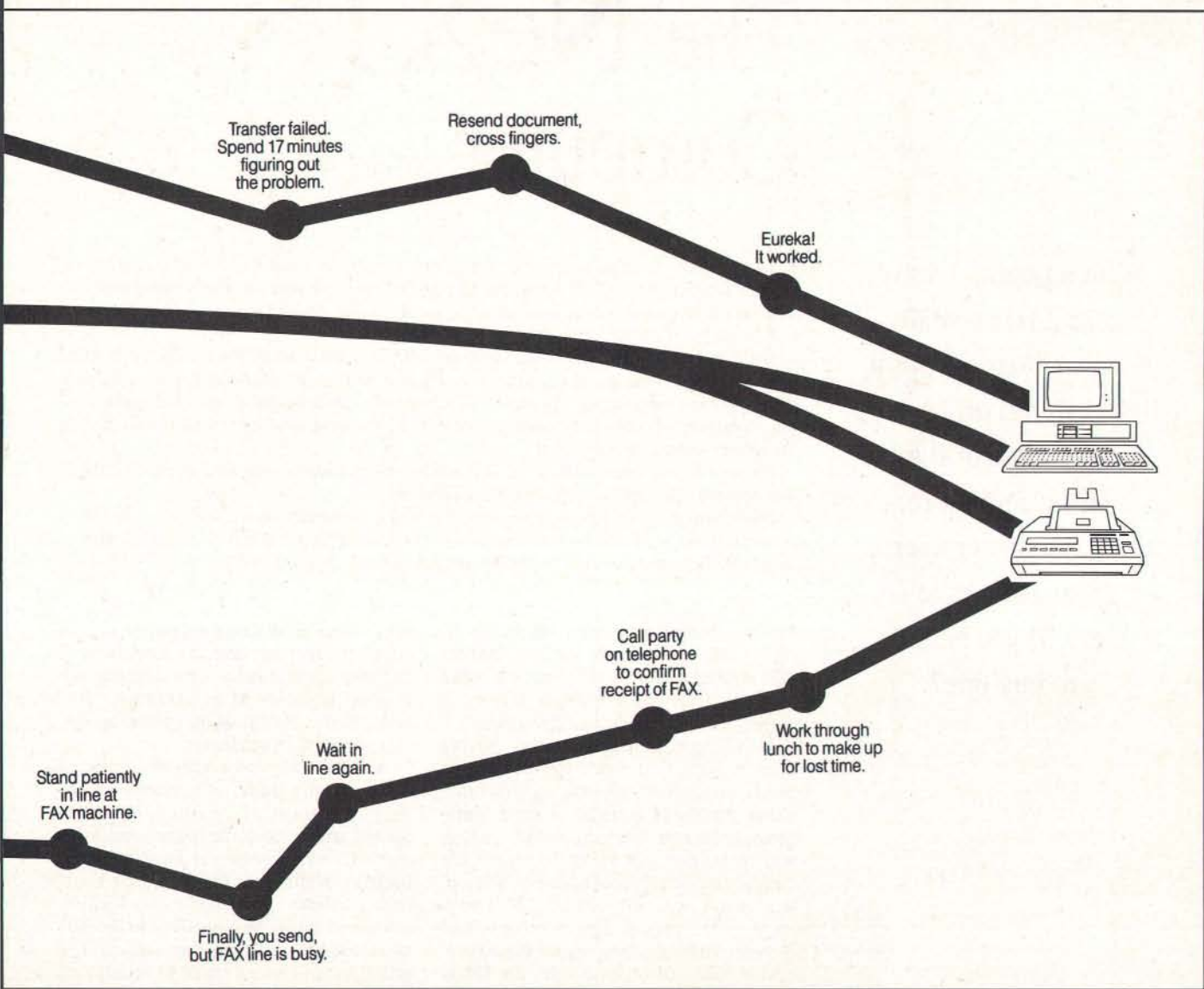

another Connection-equipped PC, you won't have to fiddle around with modem parameters or protocols. Because the Connection CoProcessor sets them for you. At 9600 bps.

Best of all, Connection supports CAS,* a new communication standard that is supported by major software and hardware developers like Ashton-Tate®, Borland®, DCA®, Microsoft®, and WordPerfect®. Which means you can send, for example, a word processing file to your London office, without ever exiting your WordPerfect program.

You just send the document directly from your application. That's it. There isn't any complicated

communications software to learn.

And everything is backed by toll-free technical support and a five-year warranty from Intel.

So what are you waiting for? Call 800-538-3373 now for a free demo disk.

Because with Intel's Connection CoProcessor, communication is really going to take off.

intel®

The NeXT Computer

With an optical drive,
a 25-MHz 68030,
built-in floating-point,
digital signal processing,
8 megabytes of RAM,
Unix, and more,
this is a power user's
dream machine—
but will you be able
to buy one?

Editor's note: *In August, Nick Baran, Tom Thompson, and I attended a marathon, all-day briefing at NeXT's headquarters in Palo Alto. It was the first time a publication was given an in-depth look at what surely is one of the most eagerly anticipated machines in recent memory: the NeXT Computer.*

On this and several follow-up visits we saw beta versions of the hardware, system software, and some early applications. We met with many of the engineers and programmers who developed the machine's hardware and software, and we spoke with the managers who are determining where NeXT is going and what role it will play in the microcomputing community.

We weren't disappointed. This is a milestone machine—one that in all likelihood will cop machine-of-the-year honors all around.

BYTE will have ongoing coverage of the NeXT Computer in upcoming issues. We'll report definitive performance figures, for example, after we receive and test a production unit. Here are our first impressions of the beta hardware and software.—FSL

It's been a long wait, but it has finally arrived. In early October, Steve Jobs's NeXT, Inc. unveiled the fruit of its creative efforts: a workstation referred to as "the cube."

NeXT asserts that the cube, having been designed to meet the computing needs of the next decade, is "the machine for the nineties." A bold statement, to be sure, but the cube goes a long way to bolster that claim: It sports the first commercially available erasable optical drive and advanced VLSI (very-large-scale integration) technology, and it comes with a built-in digital signal processor. On the software side, the Unix-based cube features an object-oriented version of C as its standard programming environment. It uses Display PostScript to present a graphical user interface that shields users from the traditionally user-hostile Unix command syntax, and it offers easy access to the cube's considerable power.

Targeted initially for the higher-education market, NeXT built the cube with the feedback of an academic advisory council that consisted of researchers and professors from schools such as Carnegie-Mellon, Stanford, and the University of Michigan.

The academic bent shows throughout. For example, the digital signal processor can be programmed for real-time labora-

tory work and demonstrations. The cube's large mass storage and memory capacity make it ideal for accessing substantial libraries of information. And Unix is the multitasking operating system of choice in academia.

Although the cube delivers a lot of bang for the buck, it's priced in the neighborhood of \$6500 (all prices quoted are aimed at the higher-education market), which may, at least initially, limit its availability to its intended user base: students. The cube's rich features list would surely be appealing to those in nonacademic settings (engineering and science applications come to mind), but we were surprised to learn that for now, NeXT has no firm plans to pursue these markets.

Outward Appearances

The cube is starkly simple in appearance and physical layout. The main computer unit is a matte-black cube measuring 1 foot to a side. There are no switches, and no indicator lights. There are two panels covering bays that can hold two 5¼-inch full-height devices. One bay is occupied by a full-height drive with a wide slot: a magneto-optical drive. The main system unit is a power user's dream: the latest generation Motorola 68030 processor and 68882 math coprocessor, plus 8

continued

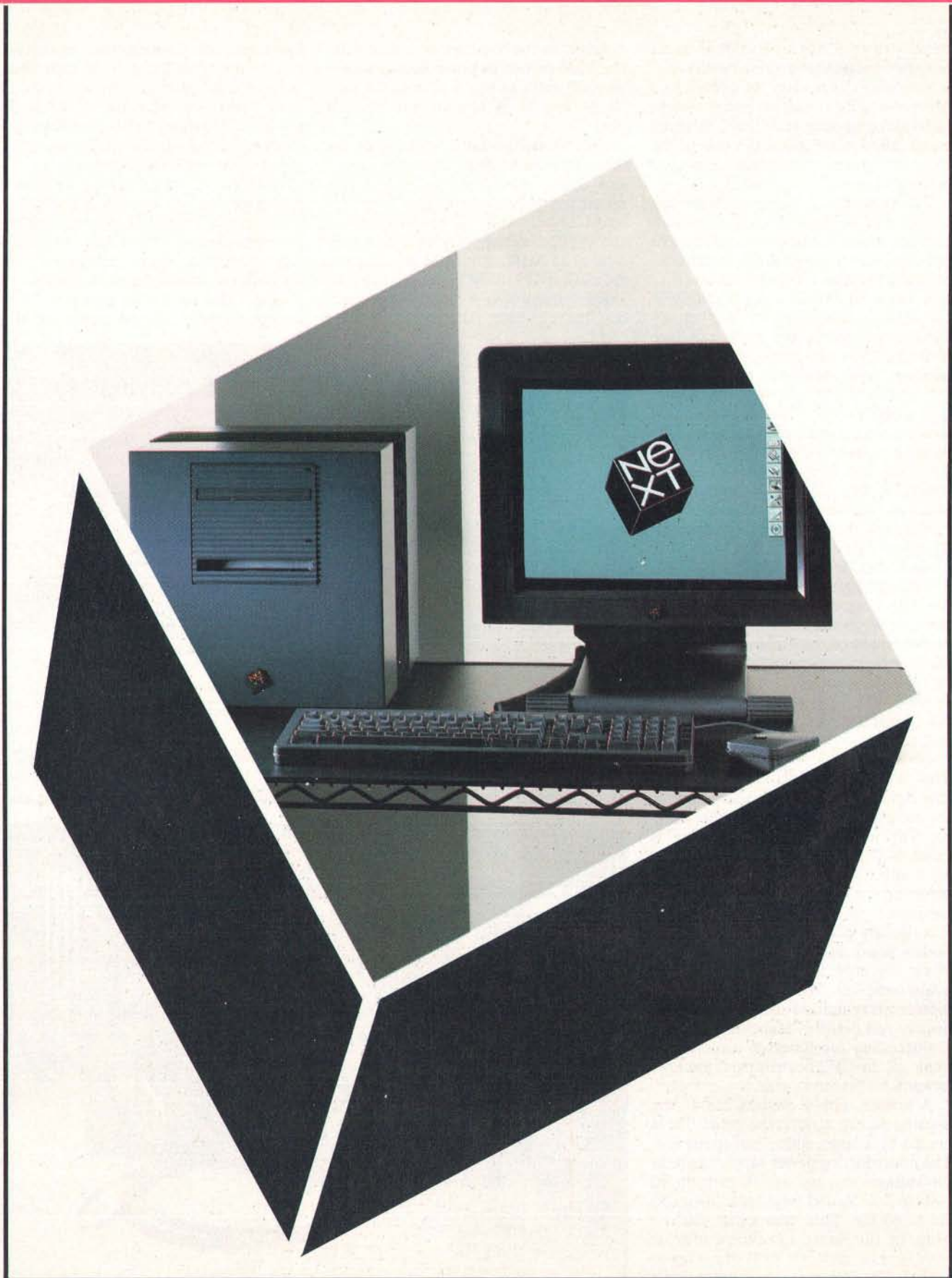

megabytes of RAM as *standard* hardware (a 4-megabyte version of the system is available). An army of connectors (such as a SCSI [small computer system interface] connector and "thin" Ethernet connector) located along the rear of the computer can hook the cube to nearly any peripheral device (see photo 1).

The system is designed to avoid the rat's nest of wiring all too common with complex systems. The entire cube system requires just one power cable, which connects the main unit to a wall socket.

A single 10-foot-long shielded umbilical connects the black 17-inch monochrome monitor to the main unit (see photo 2). This cable carries power for the monitor, video, keyboard, mouse, sound I/O, and auxiliary input signals in a complex shielded array. The black keyboard attaches via a connector to the base of the monitor, whose housing also contains a small speaker, stereo earphone jack, two stereo channel jacks, and a microphone jack. A two-button mouse (also black) connects to the keyboard (see photo 3). The beta cubes we looked at were FCC Class A certified.

This arrangement is very convenient: Your desk need only accommodate the monitor, keyboard, and mouse, and the ample length of the umbilical gives you the freedom to place the main unit well away—say, on a shelf. A key on the keyboard switches the system's power on or off so you don't have to touch the main unit at all.

Fine-Tuned for High Throughput

The cube's internal construction mirrors the simplicity of its exterior (see photo 4). The main unit's cubic housing is made of lightweight magnesium. Inside are four 32-bit NuBus slots, one of which holds the system's main CPU board. All the cube's system electronics reside on this densely packed CPU board, which makes heavy use of surface-mount devices; the cube is essentially a single-board computer. With the exception of a bipolar array used to manage the video display and perform Manchester encoding/decoding for Ethernet communications, all the CPU board's parts use low-power CMOS components.

A power supply mounts inside the housing on two screws; the entire box is cooled by a large, quiet, low-speed fan. The nonswitching power supply can handle voltages ranging anywhere from 90 volts to 260 V, and frequencies from 50 Hz to 60 Hz. This means that you can plug in the same hardware almost anywhere in the world without having to set switches. The cube should also prove

resistant to the vagaries of commercial electrical power. Its power supply generates 200 watts, of which the monitor uses 50 W, and 25 W is allocated for each slot.

NeXT's design for a workstation for the nineties used four important strategies. First, when possible, high-performance components were used. The CPU board is built around the 68030 processor and 68882 floating-point unit, both running at 25 MHz. For SCSI peripherals, the NCR 53C90 SCSI interface chip provides a maximum 4-megabyte-per-second transfer rate. That's considerably

faster than the 1.5-megabyte-per-second rate of the older NCR 5380 chip. For mass storage, an optional high-speed hard disk drive using the SCSI bus is available. This hard disk holds 670 megabytes of formatted data and has an average seek time of 18 milliseconds.

However, even a high-performance processor can be slowed to a crawl if it must service every I/O call, or wait on slow peripherals. (Steve Jobs put it this way: "MIPS is only one-third of the equation; sustained system throughput is the key.") So, the second part of NeXT's design strategy was to minimize the

Photo 1: *The cube's I/O ports. Top to bottom: DSP port, two serial ports, SCSI port, laser printer port, Ethernet port, and monitor port.*

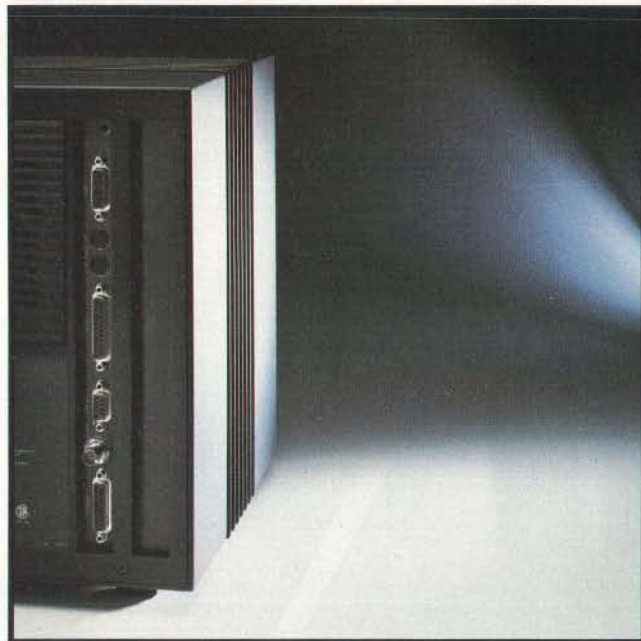

Photo 2: *The monitor I/O ports, left to right: stereo earphone jack, left and right stereo channels, umbilical connection, keyboard connector, microphone jack.*

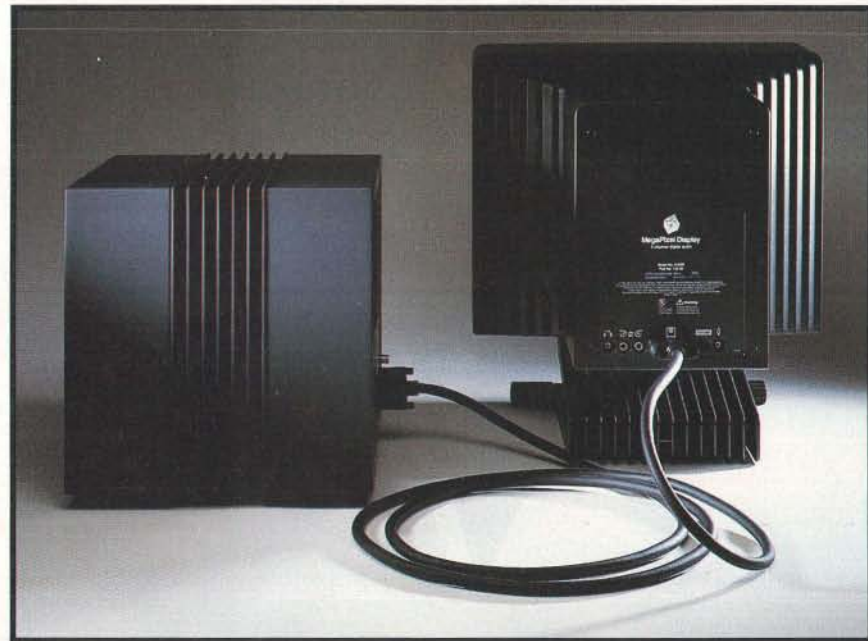



Photo 3: *The cube's keyboard. The keys above the cursor keys control the monitor's brightness, the system's power, and sound volume.*



Photo 4: *The inside of the cube. At top center is a bay for an additional full-height peripheral; at center is the magneto-optical drive. The power supply is at the bottom. To the right of center is the main CPU board.*



Photo 5: *The NeXT 17-inch monitor. The screen can be tilted forward or back; the tractor-style wheels allow it to be rolled across a table.*

overhead of communicating to the outside world by offloading as much I/O from the CPU as possible onto smart I/O processors managing each peripheral (see figure 1). This happens to be a matter of necessity given the amount of I/O the cube is doing. Consider that the cube's synthesized digital sound is handled by a Motorola DSP56001, a 20-MHz digital signal processing (DSP) chip. The DSP56001 provides the cube with its ability to synthesize compact-disk-quality stereo sound—no mean feat when you consider it must handle two channels of 16-bit data sampled at 44.1 kHz. Although the primary function of the DSP is to minimize system overhead while processing high-quality sound, you can program the DSP56001 to manipulate any sort of digital data, say, signal filtering or image processing (see the text box "The Cube's Digital Signal Processor" on page 166). The DSP makes the cube an excellent machine for laboratory and experimental work.

That's only part of the I/O traffic. Looking at the back of the cube, we counted no less than seven I/O ports. These include the following:

- A DB-19 monitor port carries all video signals, video data, control signals, mouse movement, stereo sound, and 12-V DC power to the NeXT monitor. Both the sound I/O data and video data (1 pixel every 10 microseconds) are managed by dedicated DMA (direct memory access) channels.
- A "thin" coaxial Ethernet port operates at 10 megabits per second and is driven by an AM7996 Ethernet transceiver chip.
- A DB-9 serial printer port drives the NeXT laser printer (see the text box "The NeXT Laser Printer" on page 168). This port transfers data at 1.8 mbps when printing at 300 dots per inch, and 3.2 mbps when printing at 400 dpi.
- A DB-25 SCSI port. Its signals are identical to those of the Apple Macintosh SCSI port. As mentioned earlier, the SCSI bus can transfer data to a peripheral at up to 4 megabytes per second.
- Two serial ports that use the Macintosh mini DIN-8 serial connectors and signals. Both serial ports can handle up to 230.4K bits per second synchronously (the same as Apple's LocalTalk), and 38.4K bps asynchronously.
- A DB-15 DSP port connects to both the asynchronous (SCI) and synchronous serial (SSI) channels on Port C of the digital signal processing chip. This port can be used to receive or output digital data.

continued

NeXT COMPUTER

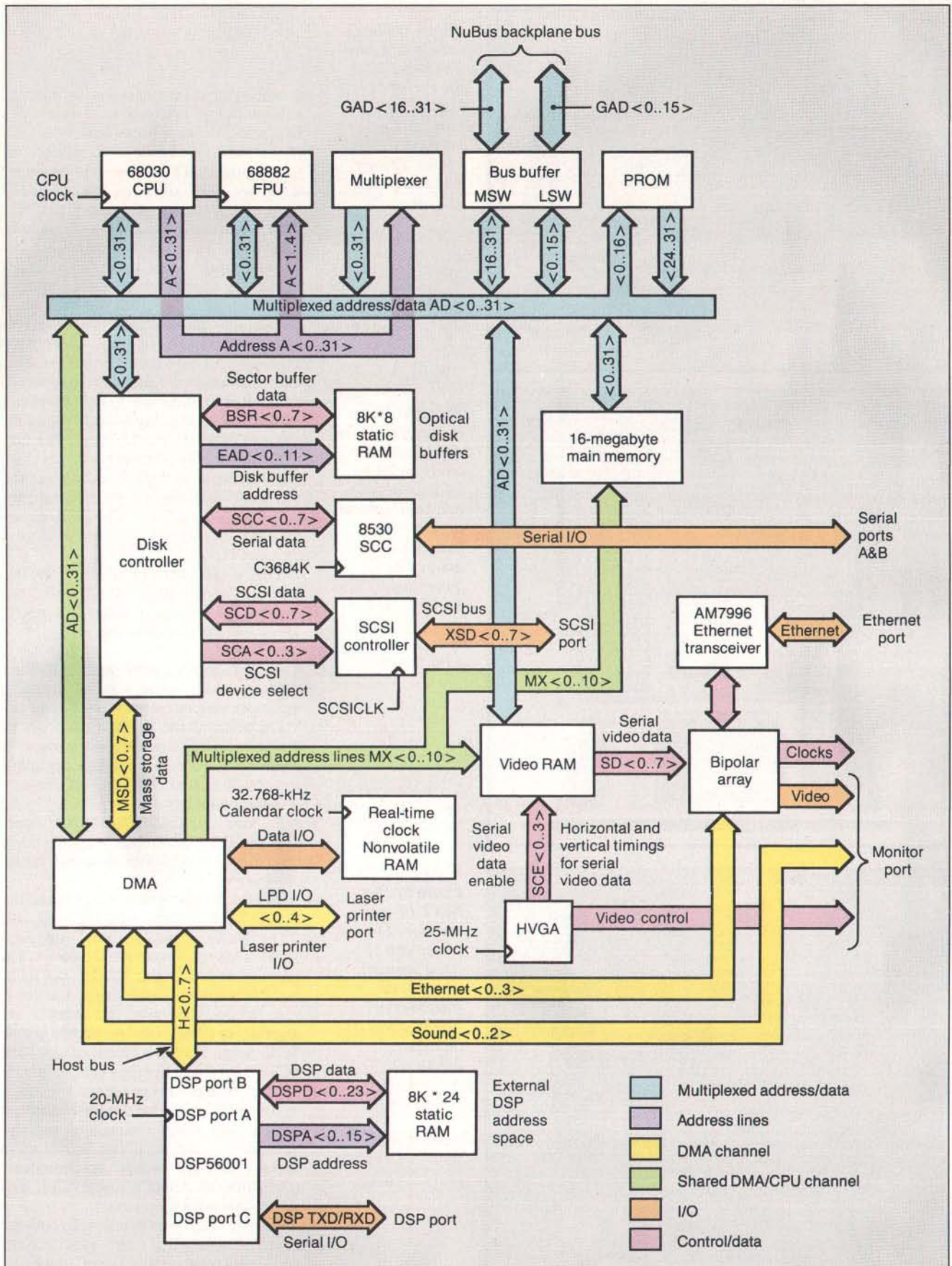

Figure 1: Block diagram of the NeXT system. Note that the PROM is read by driving 16 bits of address onto the bus and reading bytes off the most significant address lines.



The Only Character Recognition System That Outperforms Ours.

Consider the facts:

Nature's character recognition system can be trained to read all characters and languages it sees. **SPOT** (Flagstaff Engineering's Optical Character Recognition program) is trainable too. It reads most printed documents in English and more than 130 other languages.

Like nature's original, **SPOT** is very discerning. It can glance over an entire page or zoom in on a few lines of text. **SPOT** can read newspapers, magazines, books, manuals, invoices, contracts, government documents and much, much more.

Your eyes are teamed up with that marvelous computer, the brain. **SPOT** uses the latest man-made personal computers in conjunction with the

most popular low-cost scanners, and requires no additional hardware.

SPOT's advanced logic closely approximates what the human eyes and brain do. That's why **SPOT** will continue to be *the leader in OCR ...* with an intuition inspired by the original.

Seeing is believing. Since 1982, Flagstaff Engineering has helped thousands of international customers read information from various computer and printed media. Demonstration programs are available. Call today.



Circle 130 on Reader Service Card
(DEALERS: 131)



Helping People Read a World of Information

1120 Kaibab Lane • Flagstaff, AZ 86001
602-779-3341 • FAX 602-779-5998

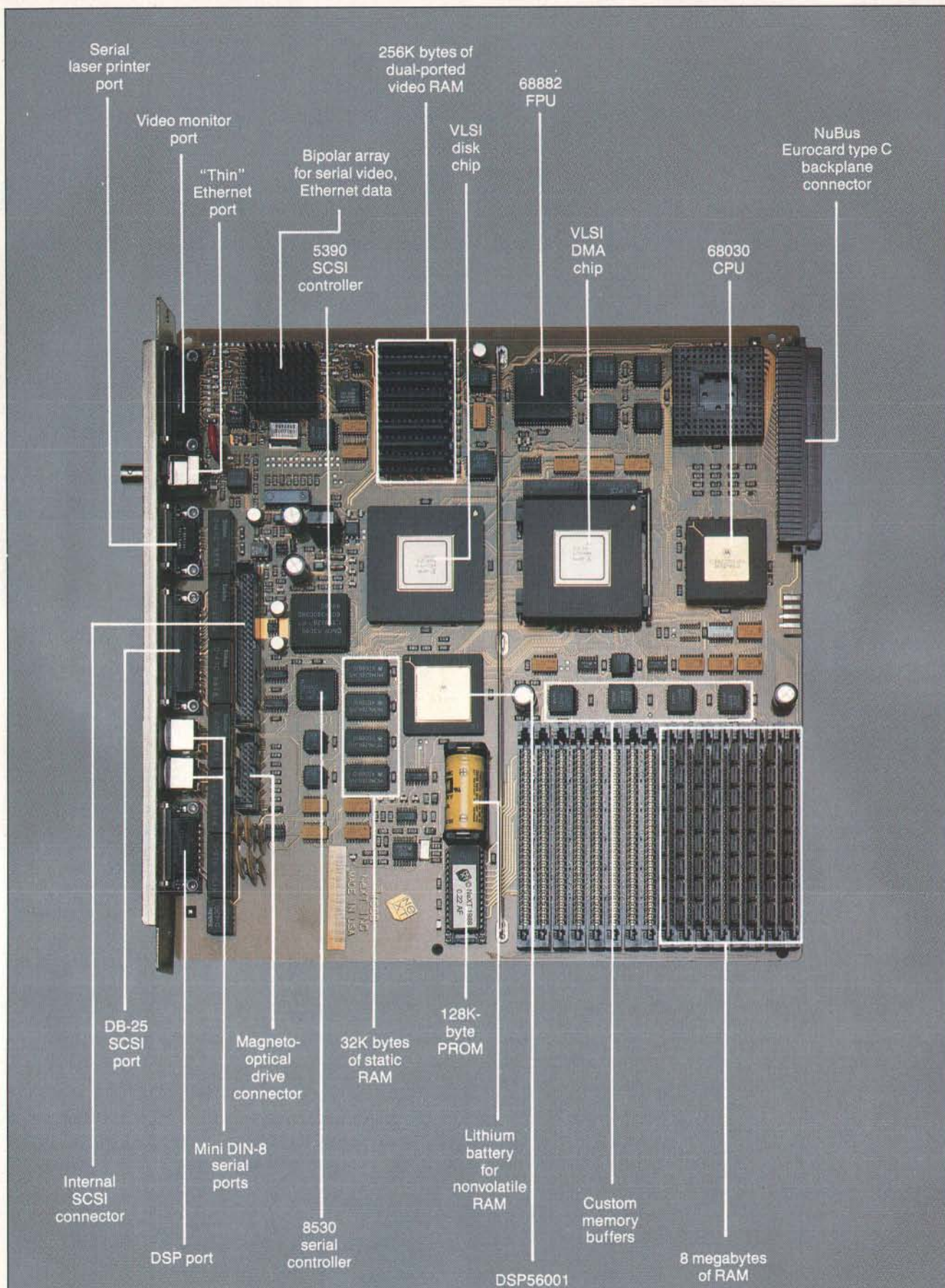

Figure 2: The NeXT Computer's main CPU board, with its two custom VLSI chips.

Looking inside the case, the main CPU board has two more ports: a 20-pin connector for the optical disk drive, and a 50-pin SCSI connector for a hard disk drive. Finally, inside the cube's housing are four 32-bit NuBus slots. Each slot uses a Eurocard type C connector. NeXT has implemented a CMOS NuBus with twice the data rate of the standard NuBus for its backplane bus. The CPU board assumes the ID of the slot it occupies. Although they're not used for outside communications, each of these devices can make demands on the system.

For digital sound synthesis, there happened to be an off-the-shelf component—the DSP56001—that could be assigned the job. Unfortunately, there aren't high-speed processors available that could deal with the rest of the system's I/O, and certainly none that could handle the magneto-optical drive. Two custom VLSI chips were designed to manage the cube's remaining I/O subsystems. These chips handle the SCSI interface, the magneto-optical drive (including error-correction logic), the serial ports, and Ethernet transfers.

Both these chips pack a lot of components: According to NeXT, each chip contains about 10 times the amount of logic circuitry used by an entire Mac II.

But there's still a problem lurking here, subtly related to I/O: how to manage data to and from these I/O processors. If the CPU must periodically transfer data between memory and the various I/O processors, the system's performance is still degraded.

NeXT's third design strategy was to improve data throughput within the system itself by managing these transfers with custom DMA hardware. This DMA hardware is implemented in one of the same VLSI chips that helps manage the system I/O. There are no less than 12 DMA channels on the main CPU board. They include the following:

- two Ethernet channels (one for transmitted data, one for received data),
- one video channel,
- one serial channel (for both serial ports),
- one DSP channel,
- two disk channels (one for the magneto-optical drive, one for a SCSI hard disk drive),
- one printer channel,
- one memory-to-DMA register channel,
- one DMA register-to-memory channel, and
- two sound channels (one for input, one for output).

For the memory-to-register and register-to-memory DMA channels, "register" corresponds to a 16-byte register buffer in the DMA hardware. The contents of these registers can be copied repeatedly under DMA control to memory. An example of this would be to copy a background pattern for the video display into the DMA registers, and then use the register-to-memory DMA channel to copy the pattern into all of the video memory.

The final aspect of NeXT's overall design strategy to improve throughput is that when the 68030 processor must access memory, it attempts to do it efficiently. The 68030's *burst read cycle* is

The optical cartridges resemble overgrown 3½-inch floppy disks, but hold a whopping 256 megabytes of data.

used where possible, since this mode allows four long words (128 bits) to be transferred in 9 clock cycles, instead of 16 clock cycles—roughly twice as fast.

Memory and Mass Storage

One way to improve system performance is to keep as much of the executable code in memory as possible, particularly where multitasking is concerned. The cube has no problem in this area: It comes equipped with 8 megabytes of 100-nanosecond SIMM-mounted RAM (see figure 2). The main CPU board has 16 SIMM (single in-line memory module) sockets, and 8 of these are populated with the standard RAM.

You can add additional 1-megabit-density SIMMs in 4-megabyte increments to expand system RAM to either 12 megabytes or the maximum of 16 megabytes.

Also located on the main CPU board are 32K bytes of 45-ns static RAM. 8K bytes of this SRAM are used for the magneto-optical disk buffers, and 24K bytes are allocated for the DSP56001. There are also 256K bytes of dual-ported video RAM for the video display. A 128K-byte PROM contains the bootstrap and some

diagnostic code for the cube. This bootstrap code simply loads the Unix kernel and starts it. There are no special graphic or system functions similar to the Macintosh Toolbox embedded in this ROM. The operating system, drivers, and custom display software reside on the boot drive.

The most interesting peripheral on the cube is its read/write magneto-optical drive. The optical drive fits into a 5¼-inch full-height bay on the cube and has a slot to accept an optical cartridge. The cartridge is removable through a software-actuated eject mechanism using an internal motor.

The optical cartridges themselves resemble overgrown 3½-inch floppy disks, complete with a rigid shell and shutter door, but the resemblance ends there; each optical cartridge holds a whopping 256 megabytes of user data. This allows you "to take your entire world with you" since the Unix kernel, the bundled applications software, and lots of user data will fit on a single cartridge.

The optical platter is composed of the same clear rigid polycarbonate material that's used in CD-ROMs. Embedded within the platter is a layer of reflective aluminum backing that's overlaid with a magneto-optical substrate. The platter rotates inside the cartridge at 3000 revolutions per minute, 10 times the rotation speed of a CD-ROM, and almost as fast as a hard disk drive.

How does the magneto-optical drive work? A single laser performs both read and write operations. To write data to the disk, the drive first applies a magnetic field to the platter. The orientation of the magnetic field determines the data to be written to the platter—either a 0 or a 1. The magnetic field is first oriented to write 0s at the start of what's called the *erase pass*.

The laser uses a high-power beam to heat a sector on the platter's substrate to its *Curie point*—the temperature at which the crystals in the substrate "forget" their previous orientation and reorient themselves to the surrounding magnetic field. All the data in the target sector is thus erased to 0s.

Next, the magnetic field is oriented to write 1s in the *write pass*, and at every spot in the sector where a bit must be set to a 1, the laser again heats the substrate to the Curie point. Finally, the sector is read in a *verify pass* to check the accuracy of the data.

To read data off the platter, the drive removes the magnetic field, and the laser directs a low-intensity beam at the plat-

continued

The Cube's Digital Signal Processor

The Cube comes equipped with a Motorola DSP56001, an 88-pin CMOS chip designed for data-intensive real-time signal processing applications. At the core of the chip are three execution units—data arithmetic logic unit (ALU), address-generation unit, and program-control unit—that operate in parallel to provide the necessary throughput.

The DSP works with 24-bit digital data, providing 144 decibels of dynamic range. Two internal 56-bit accumulators provide 336 dB of dynamic range during arithmetic operations so the precision of the intermediate results is retained during data processing.

The DSP56001 is programmable, allowing it to be tailored for a specific purpose. The 16-bit address-generation unit, combined with hardware select lines for program code or data, can access three separate 64K words of an external memory space (192K words total, where a word is 24 bits of data).

The DSP56001 has on-chip program memory composed of 512- by 24-bit-wide RAM cells, of which the bottom 64 cells are used for interrupt vectors. DSP programs can occupy the remaining memory, or if they're large, they can reside in the external program space. In the latter case, the on-chip program memory can serve as a fixed cache. Program instructions are 24 bits wide, and each bit is significant.

On the cube, the DSP56001 is clocked at 20 MHz, and instructions execute every two clock cycles to give the chip a 10-MIPS (millions of instructions per second) rating. The DSP instruction set consists of 62 mnemonics that include math, logical, bit-manipulation, loop, and program-control instructions. The math instructions encompass such operations as absolute value, add, subtract, shift left/right, shift left/right and add (useful for implementing the butterfly computation in certain fast Fourier transforms), compare, signed multiply, signed multiply and accumulate, and signed multiply accumulate and round (MACR).

All these instructions—notably some of the math instructions just mentioned—are not pipelined and execute in

one instruction cycle (two clock cycles). For example, as the MACR instruction executes, an instruction prefetch, 24- by 24-bit multiply, 56-bit add with convergent rounding, two data moves, and two pointer updates are performed, and all within one instruction cycle. Such powerful instructions are possible because of the parallel operation of the three execution units. These powerful arithmetic instructions, coupled with its high throughput, allows the DSP56001 to literally process data on the fly.

Inside the DSP56001 are four 24-bit bidirectional data buses: X, Y, program, and global. Digital data is split into X and Y components and can be treated as such in two separate 64K-word external memory spaces. On the cube, 24K bytes of static RAM provides 8K words of contiguous scalar data, or 4K words of X and Y data. How this data is ordered in SRAM on the cube is determined by what range of addresses you write into in the chip's external memory space.

The two 56-bit accumulators in the data ALU can operate on the X and Y data sets in parallel. Breaking the data into X and Y components provides certain advantages. For example, the data can be treated as X and Y coordinate data for image processing or graphics, or as real and imaginary components for complex math, or as coefficients and data for digital filtering. Each X and Y data bus has an on-chip memory composed of 256- by 24-bit cells that is used to improve performance. The program bus prefetches DSP program instructions into the on-chip program memory. The global bus is used for internal data routing within the DSP.

The DSP56001 has three I/O ports: A, B, and C. Port A has a 24-bit bidirectional data bus, and the address unit can access external memory for off-chip program code or data. Various control lines determine operations such as whether to access program or data memory, X and Y data, and if the operation is a read or a write.

Port B handles 8-bit data to and from a host processor that could be a CPU, DMA (direct memory access) hardware, or even another DSP. Control sig-

nals for this bus permit interrupt-driven or DMA transfers of data.

Port C consists of two full-duplex serial ports. The first port is the serial communication interface (SCI) that provides standard asynchronous rates up to 312.5K bits per second, and up to 2.5 megabits per second for synchronous data transmission. Although these signal timings are RS-232C-compatible, the voltage levels range from 0 volts to 5 V, so a line driver is required to produce a true RS-232C signal.

The second port is the synchronous serial interface (SSI) and is a programmable serial interface. You can set the number of bits per word, protocol, clock rate, and mode as required to transfer data at up to 5 megabits per second to and from a variety of peripheral devices.

An example of the DSP56001's processing capability is given by one of Motorola's application notes, where the chip is used as a 10-band graphic equalizer for a digital stereo system. In this document, a compact-disk digital stereo signal (two channels of 16-bit data sampled at 44.1 kHz or 88,200 16-bit digital samples a second) goes through the DSP56001's SSI on port C. Next, real-time digital filtering is performed on 20 bands (10 bands per channel), and the filtered data returns to the stereo system, again via the C port's SSI. This admittedly down-to-earth example shows the processing power that the DSP56001 can bring to bear on a problem. The sampling rate of the DSP56001 depends on the amount of data processing going on at the same time, but it can reach a maximum of 1.66 megawords per second.

As a computer peripheral, you could use the chip in any number of applications: speech synthesis, voice recognition, high-speed modems, image processing, two-dimensional graphics, and real-time filtering of digital data. Although the signed 24-bit resolution may seem limiting for some scientific and engineering applications, you can always use the cube's math coprocessor. But for those problems that do fall within this range, the DSP56001 will be more than adequate.

VGA

A new way to look at color;
a better way to buy it.

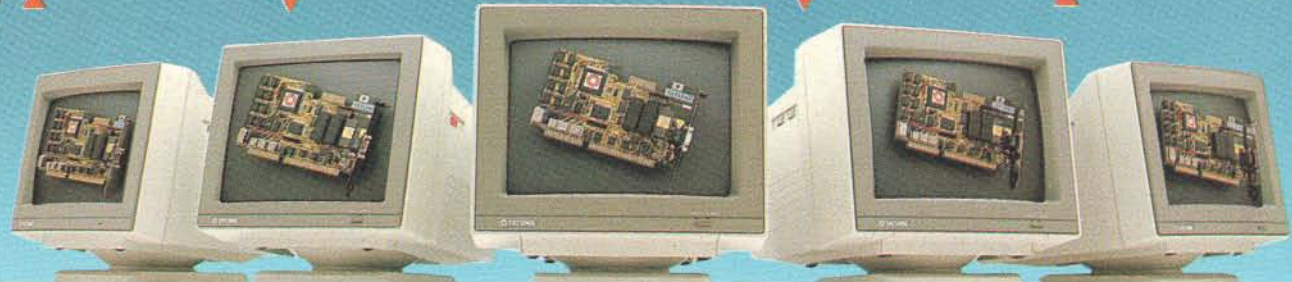

MM-1233: 12" analog monochrome. Grey scale. MM-1433: 14" analog monochrome. Grey scale. CM-1496: 14" analog color. 31mm dot pitch. CM-1492: 14" analog color. 39mm dot pitch. CM-1296: 12" analog color. 26mm dot pitch.

Advantages are enhanced by Tatung
VGA provides significantly higher resolution. In fact, image clarity is 37% higher than EGA. And while EGA gives you 16 on-screen colors, VGA puts 256 colors (from a palette of 262,144 colors) on a monitor's screen at a time. Distortion, ghosting, and even eye fatigue is sharply reduced. In text modes, characters (even those with descenders like y, p and g) are more clearly defined thanks to a 9 x 16 dot matrix. But, while the monitor is a vital part of a VGA system, we think the real key is the VGA card that goes with it.

The Tatung VGA card is all performance
Ours is a 16-bit graphics array board with a single high speed, register compatible, VGA chip...a graphics controller that's incredibly fast (it has a bandwidth more than 7 times that of other VGA boards)! You can access this speed through the 16-bit data path to display memory, BIOS ROM, and I/O. Our exclusive SwiftWrite makes the wait state virtually non-existent. More? With 16 colors, resolution increases to 800 x 600. On-board is a 256K DRAM; and the card is backward compatible with EGA, CGA, MDA and Hercules graphics standards.

Tatung Monitors deliver the new standard
We offer the broadest line of VGA monitors available; 5 newly styled and engineered monitors. Each model provides 640 x 480, 640 x 350 lines of graphics resolution; 720 x 400 lines for text. Tatung's new VGA monitors offer a broad range of features that contribute to their superior value: dark, non-glare CRT's, automatic vertical sizing encoding, multi-color text or reverse video switch, 110/220V switchable power supply, removable tilt/swivel bases...all supported by Tatung's full year warranty.

Tatung bundles provide superior value
By bundling VGA monitors and cards, Tatung puts VGA within the reach of everyone. In most cases, the Tatung VGA bundle will cost no more than EGA packages! That's why we believe that feature for feature, dollar for dollar, the Tatung VGA bundle represents incomparable value. The kind of value only the largest manufacturer of monitors in the world can deliver.

In addition, Tatung offers users a huge advantage: a Tatung VGA bundle is 100% IBM,™ VGA compatible and more...your investment in software is fully protected.

Tatung offers guaranteed compatibility
Whenever a new standard is introduced, system users have a justifiable concern about software compatibility. That's why **Tatung offers a unique guarantee*: if you note any software incompatibilities within the 1 year warranty period, Tatung will correct them free of charge within 30 days, otherwise the full value of the Tatung VGA card will be refunded.**

That's the Tatung VGA story. It's a story worth seeing. For complete information, specifications, and the name of the Tatung dealer near you, and to arrange for a demonstration, call us today. After all, seeing is believing.



TATUNG

We monitor the world.

In Southern California: (213) 979-7055

In Northern California: (408) 435-0140

Outside California: (800) 421-2929

Tatung Company of America, Inc.
2850 El Presidio Street, Long Beach, CA 90810
Tatung Science & Technology, Inc.
2060 Ringwood Ave., San Jose, CA 95131

on Reader Service Card

© XT, AT Systems and their compatibles. Refer to Tatung VGA Card Manual for specific details. All details included with each Tatung VGA card. All names trademarked are properties of their respective owners.

The NeXT Laser Printer

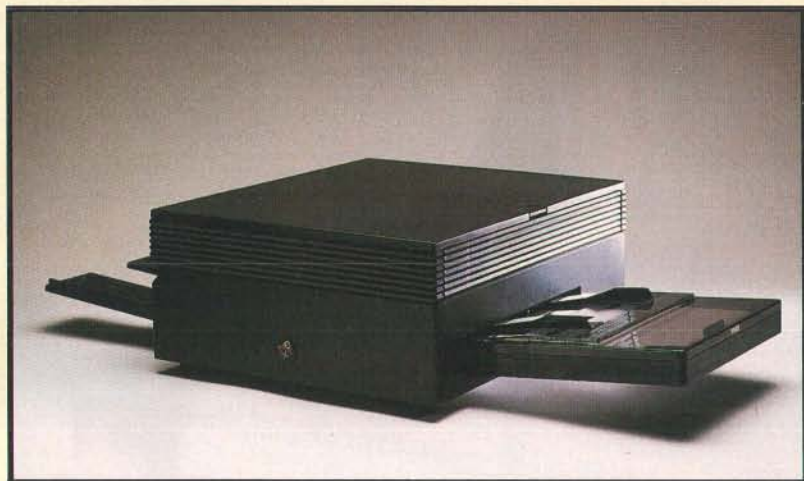

Let's face it: There are certain situations in your computer work where you must have printed output. NeXT's answer to this problem is a low-cost 400-dot-per-inch laser printer. There's no entry-level dot-matrix printer offered; NeXT is banking on users preferring laser-printed output. Since the cube handles screen imaging with Display PostScript, it also makes sense to take advantage of a high-resolution PostScript-compatible printer. The printer costs \$1995.

The NeXT printer is built around a custom-designed laser engine based on the Canon LBP-SX laser engine. It can print eight pages per minute and uses the same toner cartridge as the Apple LaserWriter II printers. A user-selectable printing mode lets the printer produce pages at either 300 or 400 dpi. The printer has its own power cord, and the

power supply is set for 110 volts or 220 V levels with a switch.

The printing process involves imaging the page inside the cube using Display PostScript, and then bit-blasting it to the printer. This is similar to the method used by Apple's LaserWriter IISC, except that the cube uses Display PostScript, and the Mac uses QuickDraw. Since massive amounts of data must be transferred to the printer to produce a page, the printer port has its own direct-memory-access channel.

One limitation of the printer is that it will only work with the cube. Also, you cannot network it like PostScript printers that use Apple's LocalTalk, although you could use a cube with a NeXT laser printer to act as a print server on a network. The cube can print to non-NeXT PostScript printers using its serial ports and Unix printer drivers.

ter. The beam travels through the substrate and is reflected off the aluminum backing. However, in a phenomenon known as the Kerr effect, the crystal alignment in the magneto-optical substrate alters the polarization of the reflected beam. The amount of beam polarization determines its intensity as it passes through a polarizing filter to a photodetector. The beam intensity indicates whether a 1 or a 0 was read at the spot on the platter.

The optical drive's I/O processor uses a robust error-correction coding to pro-

tect the integrity of the data read from the platter. (In addition to the 256 megabytes of user data, each cartridge carries a 30 percent overhead just for the error-correction code.) Data and its associated ECC information is read from the disk and fed into one of two 1296-byte buffers located in high-speed SRAM. As the data is checked and corrected for errors, it is transferred to the second buffer. It's the contents of this second buffer that is actually used by the system.

While the operation of the magneto-optical drive seems simple in principle,

the new technology needed to make this storage device possible was considerable. NeXT admitted that it had literally "gambled the company" on this technology becoming available for use in the cube.

But it did work, and one magneto-optical drive comes standard on the cube. While the drive is designed to boot and run the operating system, its 96-ms average seek time may prove a bottleneck in some applications. For the beta software, if you were using the magneto-optical drive as the system disk, you could not remove the cartridge without rebooting the system. However, NeXT plans to modify the software so you can copy files to another optical cartridge with a single magneto-optical drive.

Optical cartridges are expected to cost \$50 initially, although the price may fall as they are produced in volume. Since the cube has room for an extra 5¼-inch full-height device, you can purchase either a second optical drive for \$1495, or the 670-megabyte hard disk drive for \$3995.

Getting the Picture

As we used the cube, we couldn't help being impressed by the crisp quality of its display. This is no accident: The 17-inch NeXT monochrome monitor has an ample 1120- by 832-pixel display that contains more pixels than most 19-inch monitors (which usually have 1024 by 768 pixels). The monitor has a 94-dpi screen, as compared to the Macintosh's 72-dpi screen. However, this display is only 2 bits (four gray levels) deep. The graphic interface looks very good and makes effective use of the four gray levels.

A 17-inch monitor was chosen for the video display as a compromise between display size and weight. On the monitor's base are two small tractor-style wheels that let you move the monitor easily across a table surface (see photo 5).

The video display has a bandwidth of 100 MHz, with a vertical refresh rate of 68.3 Hz. The monitor uses the positive and negative 12 V DC supplied by the cube's monitor port for power. Inside the monitor's housing are two boards. A step-up transformer on the first board generates the high voltages required to drive the video tube. The second board handles the rest of the I/O managed by the monitor: keyboard, mouse, and sound.

The 84-key keyboard connects to a port located on the monitor's base. The keyboard also has cursor keys, a numeric

continued

This is the year of the dragon. Harness its power and reap its good fortune.

It's a year that begins with a powerful array of computer systems designed, engineered, and manufactured exclusively by us...business/professional systems that proudly carry our name.

Leading the way is our new TCS 8000. Designed to harness advanced 80386 microprocessor technology, it is remarkably powerful, extremely fast and extraordinarily versatile. The TCS 8000 gives you all the strength of the MS-DOS™ concurrent DOS 386™ PC MOS 386™ and the incredible capabilities of OS/2™

The TCS 8000 is equipped with 1MB of memory, but it will easily accommodate up to 16MB on the motherboard by utilizing memory modules...standard modules that dramatically reduce the cost of expanding memory and increasing memory access speed.

As part of a network, in multi-user system, or as a stand-alone system the TCS 8000's performance proves that every detail has met Tatung's uncompromised quality controls.

Like the ancient dragon, the TCS 8000 is a symbol of power and good fortune. It will provide your customers with tremendous value, and you with superior profitability. Indeed, the exciting new TCS 8000 is destined to be a genuine "fire breather."

For complete details and specifications, call toll-free: 1-800-421-2929 Ext. 256.

The remarkable TCS 7000 AT compatible.



The TCS 4000... AT compatibility in a very small footprint.



TATUNG

Advanced thinking is an ancient art.

Circle 329 on Reader Service Card



Tatung Science & Technology
2060 Ringwood Ave.
San Jose, CA 95131
(408) 435-0140
Outside California:
(800) 421-2929

All trademarks are the property of their respective manufacturers.

Tatung Company of America, 2850 El Presidio Street, Long Beach, California 90810 (213) 979-7055

Display PostScript

Display PostScript is an extension of Adobe's PostScript page-description language (PDL) and is designed as an imaging model for graphics displays. In theory, software developers could write the display portions of their applications just once using Display PostScript: These applications would run without modification on any computer and operating system that supports Display PostScript. Another major benefit is that the image on the screen would reproduce identically on a printer supporting the PostScript PDL.

Display PostScript is device-independent, an important feature when you consider that specific dimensional sizing is display-dependent in most graphics handlers. For example, if you write a Display PostScript routine to draw a 2-inch square on the screen, the routine will always draw a 2-inch square on any display supporting Display PostScript, regardless of the resolution, color capability, or size of the output device. In other words, Display PostScript permits a "non-unitized" description of an image until it is interpreted for a particular display.

This non-unitized approach is in contrast to pixel-based graphics handlers that can only handle proportional sizing. Of course, you can also specify proportional sizing in Display PostScript. Additionally, Display PostScript automatically uses the maximum color capabilities of the host display, whether it has just black and white, or 16 million colors. The programmer does not have to worry about the characteristics of the output device while writing the application.

The core of Display PostScript is called the DPS Kernel. The DPS Kernel is an interpreter that translates PostScript routines into the images on the

screen and is designed to be machine-independent. The DPS Kernel is supplied precompiled in object format to the OEM.

In addition to the Kernel, Adobe supplies the OEM with "front- and back-end" adapters that consist of source code for interfacing to the display devices, the operating system, and the windowing system. The Display PostScript adapters become part of the host computer manufacturer's system software. Of course, modifying these adapters for the host computer system is not a trivial task, and it is usually undertaken by the OEM as a joint or cooperative effort with Adobe Systems. Again, the important point here is that the software developer need not worry about these "adapters."

The main underlying concept of Display PostScript is to isolate the display operation from not only the host computer's operating system but also from its windowing system. The core of Display PostScript fits inside the host windowing system, which in this case is the NeXT windowing system, although it could be anything from Microsoft Windows to X-Windows to QuickDraw.

While the windowing system handles functions such as cut, paste, and copy, and manages the window boxes on the screen, Display PostScript handles the actual painting of the window's contents. Thus, routines for displaying icons, text fonts, and graphics images have to be written only once using Display PostScript. However, the software developer still has to write separate window calls for each windowing system.

Programmers can use the Display PostScript language directly, or they can use a library of C procedures called

PSWrap, which is recognized and interpreted by the DPS Kernel.

NeXT fully supports the PSWrap library, but has added many of its own procedures. Some of these are used by the Application Kit to create and manage windows; other procedures handle events, mouse, and cursor operations; and still others support "compositing."

The compositing procedures are multibit pixel operators designed by NeXT's sister company, PIXAR. Each pixel has two values associated with it: its data value (or color), and its alpha value (the data's transparency or opacity). On the cube's 2-bit display, compositing makes an icon transparent as it moves over another object on the screen. These compositing operators are easily extendable and will allow the NeXT software to migrate to color displays when the time comes.

From brief glimpses of alpha versions of Display PostScript, several industry observers have concluded that Display PostScript has serious performance problems—it is too slow. Adobe Systems vehemently denies this and says critics have jumped to conclusions based on these preliminary demonstrations. Adobe says Display PostScript is very fast provided the code is written properly.

A number of techniques have been developed to improve Display PostScript's performance, including a binary preprocessor (described below), graphic state objects (multiple PostScript graphic states that can be switched quickly by changing a pointer), and user paths (an aggregate of PostScript drawing commands that represent a PostScript path). NeXT uses these techniques and its own compositing functions to boost the speed of the display.

keypad, a power-on/power-off key, and pairs of keys that control the volume and screen brightness (pressing one key increases the chosen output; pressing the other decreases it). There are two Command keys and two Alt keys (located on opposite sides of the keyboard) that are mapped separately. There are no PC-style function keys. A two-button opto-

mechanical mouse also connects to a port on the keyboard.

There are also left- and right-channel analog stereo jacks, and a jack for stereo headphones on the monitor's base. There's also a jack for a microphone so you can record sounds through the monitor, say, for voice mail. This port uses a telephone codec input that's sampled at 8

kHz, and it uses 8-bit Mu-law scaling for the digitized data. The data is saved within a Sound object that can be utilized by the NeXT Unix mail facility or by NeXT applications.

The Software

As much as the NeXT hardware represents an impressive step forward in areas

As an example of how binary encoding works, say we want to issue the PostScript operator `72 426 moveto`. Normally the DPS kernel would have to translate the ASCII digits 72 and 426 into a floating-point format, and the ASCII `moveto` operator into a binary code. A lookup table uses this binary code in the DPS Kernel to steer execution to the routine that implements the `moveto` operation. A NeXT application normally calls a `PSWrap` function, `PSmoveto()`, that passes the IEEE 754 floating-point values of the numbers to the DPS Kernel, along with the corresponding binary code for `moveto`. This effectively eliminates the overhead of the ASCII translation stage for the DPS Kernel. The NeXT DPS Kernel can process ASCII PostScript commands if required.

Display PostScript has one major limitation in that it does not support three-dimensional imaging. It is therefore not suitable for CAD software. Adobe admits that Display PostScript is not intended for high-end mechanical design applications. (Steve Jobs said that NeXT will support the Renderman Standard, which he called "the PostScript of three-dimensional graphics.")

Display PostScript has some very compelling features for software designers and for end users. It could greatly facilitate the porting of software applications across incompatible hardware systems.

But the various competitors for display standards—such as IBM and Apple—will have to make some compromises before Display PostScript can succeed. Until these compromises are made, both the end user and the software developer will continue to be plagued by an incompatible world of competing display standards.

such as digital signal processing, optical disk storage, and VLSI technology, the NeXT system software is a step forward for software technology. The system offers an easy-to-use graphical interface to Unix and an object-oriented programming environment for programmers and software developers.

It's an understatement to say that

NeXT expects Unix to catch on. Steve Jobs told us, "I believe this with every bone of my body: Unix will be the prime operating system of every major company in the 1990s."

So it's not surprising that the cube is a Unix-based system. It features a proprietary windowing system that is designed to shield the Unix command-line interface (CLI) from the user, substituting simple point-and-click mouse operations to manage files and execute applications. NeXT also uses Adobe Systems' PostScript imaging model (often referred to as Display PostScript) for displaying all text and graphics on the screen. Display PostScript is an extension of the PostScript page-description language (see the text box "Display PostScript" at left).

The NeXT system software also includes development tools for building application interfaces and integrating objects into application programs. These tools are called the Interface Builder and Application Kit, respectively.

The Operating System

NeXT uses the Mach Unix kernel developed at Carnegie-Mellon University. The Mach kernel is compatible with BSD (Berkeley Standard Distribution) Unix version 4.3, but provides major enhancements such as shared memory, fast inter-process communication, and potential multiprocessing support through the use of threads. Shared memory allows multiple processes to share common segments of memory. IPC allows processes to communicate with other processes and to transmit messages and data between them. Threads are "lightweight processes" that have their own execution stack, but within the context of a task that created it (i.e., the thread has access to all the resources made available to the parent task such as memory, and opened files).

Multiprocessing support is possible by assigning threads to particular processors. However, multiprocessing is not supported in the initial release of the NeXT operating system. Since you can add multiple CPU boards to the cube's backplane, we can expect to see multiprocessing support in later releases of the operating system.

In NeXT's first release, the operating system consists of a single kernel with the Mach implementation of IPC, scheduling, and virtual memory operating as a layer within the BSD Unix kernel. However, the ultimate goal of the Mach implementation is to provide a modular architecture for Unix that would allow for a much smaller kernel with separate pro-

cesses dedicated to file handling, networking, and Transmission Control Protocol/Internet Protocol (TCP/IP).

Like most Unix-based systems, the cube implements virtual memory using a paged-memory system to allow applications to run even if their memory requirements exceed the available physical memory. Idle portions of a running application are "paged" (i.e., written to disk) in 8K-byte blocks, called pages. However, as in all virtual-memory systems, it is possible to overload the system with too many applications, causing excessive paging or "thrashing," which can bring the system to a crawl. While NeXT was not ready to provide numbers for the amount of memory consumed by the system software, the 8-megabyte base memory configuration is designed to allow "three or four" applications to run

I t's an understatement to say that NeXT expects Unix to catch on: The cube is a Unix-based system.

simultaneously in addition to the system software.

For networking, NeXT uses TCP/IP and Sun's Network File System, which has become the standard Unix file-sharing system. Since the cube comes with an Ethernet interface, it is "network-ready" for TCP/IP-based networks. The thin Ethernet cabling allows up to 600 feet of cabling and connection of up to 30 machines without gateways or repeaters. While NFS does not require one, a dedicated server is preferable in networks of more than a few machines, due to performance degradation. In other words, if you're planning to network a bunch of cubes, you'll need a dedicated NFS server, or a cube to serve that purpose.

User Interface and Window Server

NeXT provides a graphical windowing interface to Unix that hides the laborious Unix commands from the user. While veteran Unix users still have the option of

continued

issuing those intuitive commands (like `grep` and `ls`) within a Unix CLI window called the Console, most cube users should never have to deal with Unix. The windowing interface, called the Workspace Manager, provides all the necessary functions for file management, opening and closing applications, and communicating with other resources on the system such as peripherals or nodes on the network.

The main interface screen is called the Workspace (see photo 6). Noticeably absent from the screen is the ever-present menu bar found on the Macintosh screen, or on a PC running Windows. Unlike the Macintosh Desktop, menus can be moved anywhere on the Workspace and float above any open windows.

Menus are hierarchical, and you can split off subhierarchies from their parent menus. Windows have scroll bars located on the left and bottom, and there are small boxes on the window frame for resizing or closing the window. It also has a "miniworld" function that collapses the window and its menus into an icon while the process owned by the window continues to run.

Icons become transparent when they overlay other icons, allowing you to always see everything that's currently available on the Workspace. The icons of frequently used applications can be "docked" along the right side of the Workspace for easy recall.

The Workspace is similar to the Desk-

top metaphor on the Macintosh, and the Workspace Manager is analogous to the Mac's Finder. However, no one will accuse NeXT of copying Apple's look and feel.

The Workspace resembles the Desktop, but no one will accuse NeXT of copying Apple.

File management operations are similar to those used by the Mac Finder. When you click on a directory in the Workspace, you can examine the directory in a number of ways. There is a "browser window," which displays the directory tree in a window with the directory hierarchy ordered from left to right on the screen. This browser window normally lets you see three levels deep, but you can position the point in the hierarchy where you wish to view files, or resize the window to examine additional levels.

You can also choose to view the direc-

tory as icons with subdirectories represented by folders, or as a conventional text-only Unix directory listing.

The version we saw was definitely beta, so the final word on the Workspace will have to wait. Nevertheless, it seems very intuitive and easy to learn. Its performance seems good, and the display quality is excellent.

Rather than use an existing Unix window server such as X-Windows, NeXT designed its own proprietary Window Server. The Window Server manages all interactions between the windows, keyboard, and mouse for all applications attached to it. The Window Server obtains events from the operating system and handles the ones it can (e.g., resizing a window or moving it to another part of the screen). If it's not an event that it can service, the Window Server determines which application can and dispatches it to that application.



Embedded inside the Window Server is the Display PostScript interpreter, which acts on the PostScript commands passed to it. This embedded interpreter executes the PostScript commands it receives and writes the results into the cube's video RAM, making it appear on the monitor.

The Window Server supports Mach IPC connections as well as connections through TCP/IP, allowing other cubes on a network to access another machine's Workspace. The proprietary Window

continued

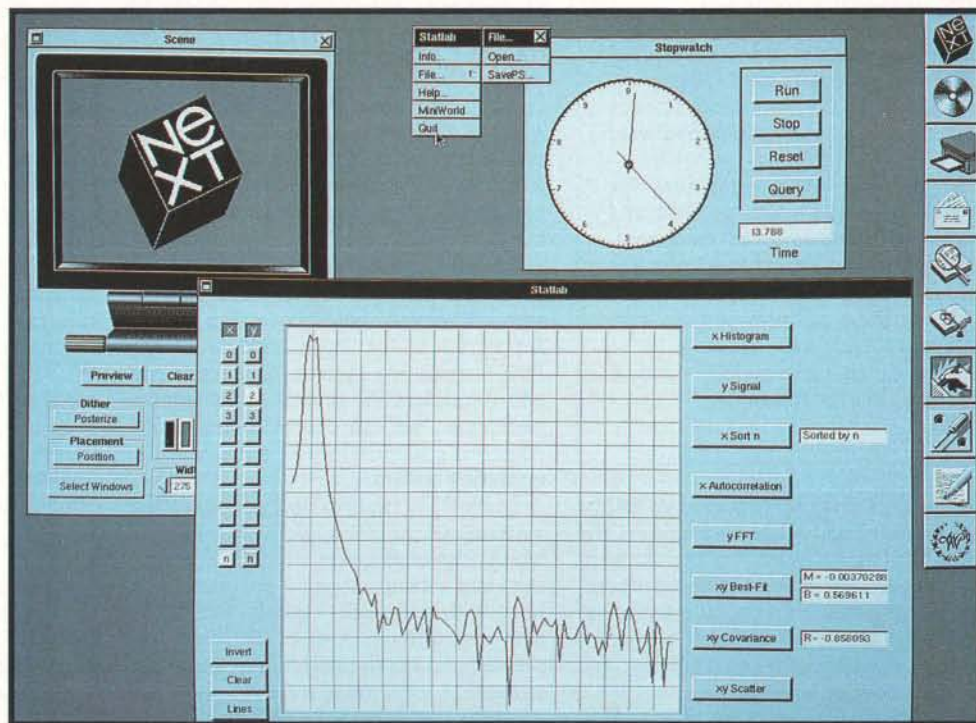
Photo 6: The cube's Workspace. Each window represents a running application. Note that the menu has its own Close box. The icons at the right represent "docked" applications.



In 1988, \$3.5 billion in micro-computer software will be sold worldwide. During that same time, another \$3.0 billion in sales will be lost to free distribution — better known as software piracy. And right now, Rainbow Technologies' Software Sentinel™ is protecting close to \$1.0 billion in software for developers who never wanted to be part of the free software distribution network in the first place.  The Software Sentinel hardware key is “execution control” software protection. It ships with the software and simply plugs into the PC's parallel port to be one hundred percent invisible to both user and the software. Users can make as many copies as they want. Make working submasters. Use a hard disk. Virtually anything that can be done with unprotected software. Except start freely distributing that software to other users.  The family of Software Sentinel products. Selected by the very big to the not-so-big developers of DOS, OS/2 and Xenix software in worldwide markets. To the cool tune of close to a billion dollars. So far.

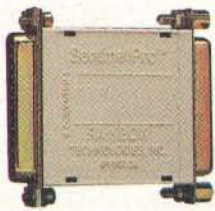

Come see us at COMDEX, Booth W747.



RAINBOW TECHNOLOGIES

18011-A Mitchell South, Irvine, CA 92714 • (714) 261-0228 • TELEX: 386078 • FAX: (714) 261-0260
 Rainbow Technologies, Ltd., Shirley Lodge, 470 London Rd., Slough, Berkshire, SL3 8QY, U.K., Tel: 0753-41512, Fax: 0753-43610

Copyright ©1988 Rainbow Technologies, Inc. Software Sentinel and SentinelPro are trademarks of Rainbow Technologies, Inc.
 Xenix is a trademark of Microsoft Corporation. OS 2 is a trademark of International Business Machines Corporation.

Bundled Software

Here is a list of the software that is scheduled to be bundled with the NeXT Computer. It includes the Mach operating system and its development software. Also included are the works of Shakespeare, a dictionary, and a thesaurus.

You can call up quotations or the dictionary entry for a specific word at any time by using the cube's Find function. This capability would be valuable not only to college students and faculty members, but to anyone who has to write frequently—whether it's a business proposal or a technical document.

System software:

Mach operating system
PostScript Window Server and fonts
System administration tools

Development tools:

GNU C compiler
GNU debugger
GNU EMACS
Objective-C 4.0
Berkeley Unix utilities
Terminal emulator
Window-based text editor
Interface Builder

Object-oriented software kits:

Application Kit
Sound Kit
Music Kit

High-speed text-retrieval application (called "Find") for

Standard reference works:

*Merriam-Webster's Ninth
New Collegiate Dictionary*
*Merriam-Webster's Collegiate
Thesaurus*
*The Oxford Dictionary
of Quotations*

Documentation for all bundled software: user's manuals and programmer's manuals

Literature:

Oxford University Press' William Shakespeare: The Complete Works

User-created text files, such as mail or documents

Applications:

Personal text database
Electronic mail application with graphical interface and ability to attach voice messages
Word processor
Window-based file manager
Mathematica
(Wolfram Research, Inc.)

program. An object consists of data (called instance variables) and executable code. If the object is to be visible on the screen (a window, for example), the code also contains an entity called `drawSelf::` that's composed of C code, Objective-C code, and PostScript code, which is used to describe the appearance of the object to the Window Server.

Probably the key concept with respect to user interfaces is that objects can respond directly to messages generated by user actions. Rather than having to write lines of conditional statements in C code to respond to user actions, the user actions are interpreted as messages other objects can understand. For example, you might have an object in your program called "Window," which can understand the "Close" message sent by a user response.

NeXT provides a program called Interface Builder that allows you to interactively build user interfaces for your programs. Interface Builder lets you design the layout of a graphical user interface by selecting buttons, menus, and other objects from an object library to include in your application.

This function is somewhat similar to ResEdit on the Macintosh. However, Interface Builder goes further—it allows you to define connections between objects. That is, Interface Builder lets you specify actions for the objects to perform in response to user actions on other objects. For example, you could build a Beeper button object into your program interface simply by selecting a prototype button from Interface Builder's on-screen inventory, moving it to where you want on the screen, giving it a label, and assigning an action (say, emit a beep) to be performed when a user clicks on the button.

This is similar to the function of HyperTalk in Apple's HyperCard program. The big difference, however, is that Interface Builder generates the binary description of the object that you can integrate into programs.

You can also create custom objects by selecting an object that most closely resembles what you want and customizing its appearance and behavior. NeXT's goal is to supply enough objects so that a programmer could select objects and define their connections, making it possible to build an application from scratch writing little or no code.

In addition to the Application Kit and Interface Builder, the NeXT system software includes kits for working with music and sound. The Music and Sound Kits provide objects for integrating these

Server means that existing applications that run on other Unix windowing systems will have to be modified to run under the NeXT windowing system. However, a Unix application that uses conventional console I/O will run inside the Console window without modification.

The Development Environment

The primary objectives of the NeXT programming environment are to simplify the development of interactive user interfaces and to simplify the creation of new applications through the use of object-oriented programming.

Other systems employing graphical interfaces—like the Macintosh, for example—are great for the end user but extremely complex for programmers, particularly in developing a working user interface. To ease the burden of this task for the developer, the NeXT system in-

cludes tools for building interfaces to the NeXT windowing system, and also tools for object-oriented programming.

The NeXT system software includes an ANSI C compiler and an object-oriented preprocessor called Objective-C, developed by Stepstone Technologies. Objective-C allows you to define objects as groups of C procedures.

NeXT provides several libraries of ready-to-use objects, called *kits*, for integration into Objective-C programs. These kits provide a library of around 34 objects for implementing the core functionality of a NeXT application, although a programmer would normally use only a small subset of these objects. This library is known as the Application Toolkit, and the Objective-C interface can access it directly.

Object-oriented programming allows a one-to-one correspondence between objects on the screen and objects in your

features into your programs. There is also a number of library functions (not objects) that allow you to tap into the processing capabilities of the DSP. These libraries provide some 50 functions for performing tasks like fast Fourier transforms, and spectral filtering.

NeXT supports the concept of "shared libraries" in its development environment. This means that multiple applications and processes can share a single copy of executable code from the object library. Although library sharing was not implemented when we saw the cube, it should improve performance and reduce the memory and storage requirements of applications.

Applications

NeXT will bundle several applications with the machine. These include the word processor, WriteNow, that is owned by NeXT and is currently distributed by T/Maker for the Macintosh. The system software also includes the standard Unix Mail program equipped with a graphical front end that can attach voice messages to mail files, a file-searching program called Find, C and Objective-C, a symbolic debugger, and on-line documentation. It also has educational and reference tools such as *Webster's Dictionary*, the complete works of Shakespeare, and Mathematica from Wolfram Research (see the text box "Bundled Software" at left). A personal text database allows you to automatically index all your word processing and electronic mail communications so you can recall documents or memos based on keywords instantly.

An important goal of the NeXT software environment is the development of "digital libraries." With its erasable 256-megabyte magneto-optical disk, NeXT hopes to promote the idea of easily accessible text databases. In the educational market, these databases will include encyclopedias, dictionaries, textbooks, and other reference works.

NeXT's first software release lays the groundwork for the company's plans for the nineties. The DSP and the kits for programming it offer exciting possibilities for new real-time applications. It will be interesting to see how the software will be used and what new applications will be developed.

One Giant Step Forward?

The cube is an impressive technical achievement. We liked the carefully thought-out design that didn't just use fast components, but covered every aspect of moving information through the

system. The choice of NuBus for the backplane bus is an excellent one; it goes a long way toward providing the hardware support for the cube's planned multiprocessing capability.

Considering the amount of information that the machine is expected to use, the high-capacity magneto-optical drive is a good design choice. The graphical interface uses the well-documented PostScript imaging language and goes a long

Considering
the machine's
capabilities, we can't
help but wonder if
NeXT is being too
conservative in its
marketing plans.

way toward hiding the uglier side of Unix from the user. The facility with which NeXT's object-oriented programming environment reduces the work needed to write an event-driven program is also impressive.

It is indeed a machine for the nineties. It represents a bold step forward both in hardware and software design and effectively redefines what constitutes "standard equipment."

However, as we go to press, some big questions remain unanswered. One relates to the performance of the machine. In our limited time with several beta cubes, it was difficult to judge the overall performance. Display PostScript operations were very fast, putting to rest the controversy of Display PostScript's performance, at least as far as the cube is concerned.

However, disk read/write operations seemed pretty slow—perhaps because so much beta debugging code was being carried along as baggage, and because library sharing was not yet implemented. We saw the magneto-optical disk drive in operation, but it still had some operating bugs, and its 96-ms access time might be a source of frustration if it's used as the main system drive. At this point, we cannot comment on its reliability.

Another question is whether software

developers will support NeXT. The primary obstacle to the acceptance of Unix in the general marketplace has been the lack of software applications. Software developers are faced with choosing between Macintosh, OS/2, DOS, and now a new version of Unix with a proprietary windowing system. To be successful, NeXT will need substantial support from software developers; at the time of our visit, only about 10 developers had signed on, and NeXT would not release their identities.

The concern about outside development is perhaps tempered by two facts. First, the object-oriented environment should simplify moving existing Unix programs to the machine. Second, each cube is a complete development system, since all the development tools—compilers, object libraries, and Interface Builder, are bundled with the machine.

Then there's the question of NeXT's target market—higher education. While the machine is certainly a perfect fit for the university community, universities are not known for being big spenders. Certainly, many students will have a hard time coming up with \$6500 or more for a computer, let alone another \$1995 or so for the laser printer, and perhaps \$1495 for a second magneto-optical drive for backups.

Of the cube's design, Jobs told us, "If you want to make a revolution, you have to raise the lowest common denominator." That's true, but you also have to get the product into the hands of enough revolutionaries to make a difference. Yet it's clear NeXT is thinking small, at least in terms of initial marketing.

Dan'l Lewin (NeXT's vice president of marketing and sales) told us, "We built the company not to need huge numbers." And Jobs said, "We'll focus on other markets in the future, but we're not going to do it today. There's no reason why we can't do very well in [the educational] market alone."

Perhaps. But considering the machine's capabilities, we can't help but wonder if NeXT is being too conservative in its marketing plans. If so, it seems that NeXT may have to be able to endure some lean years until the machine catches on in the early nineties. ■

Tom Thompson has a BSEE from Memphis State University and is a BYTE senior technical editor at large. He can be contacted on BIX as "tom_thompson."

Nick Baran has a BSME from Stanford University and is a BYTE technical editor based in San Francisco. He can be reached on BIX as "nickbaran."

Dell are about to
give you
something more.

Less.

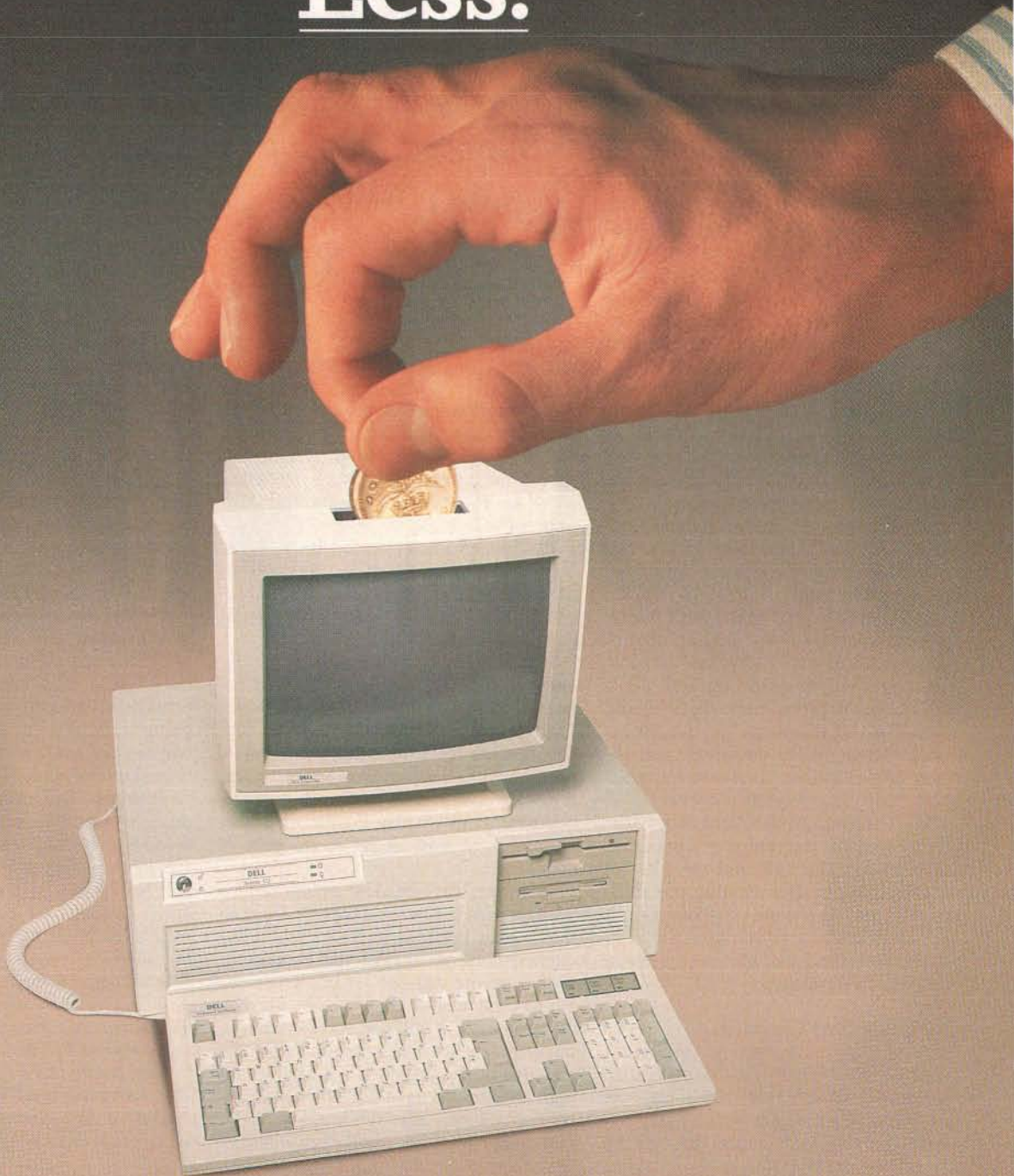

Dell gives you more – the Dell System 325.

The question that everyone's been asking is not 'if' but 'when' Dell would launch a 25 MHz 80386 machine. The answer always was, when we knew it was wanted and when we could be certain of offering the quality, reliability and service that Dell has become known for – at a price that's highly competitive.

That time has arrived.

Dell gives you less – new lower prices.

When a company starts to make an impression on the market, there's a tendency to restructure their pricing scheme. Prices usually go up but there's no guarantee that you're getting the same package for your money. You can end up with less for more.

Dell is different. The success of the Dell package since its introduction to British PC Users in 1986, means we can take a new look at our prices. Our direct relationship with our customer, aimed at giving you exactly what you want in the most cost-effective way, has enabled us to bring our prices down further with no compromise on service.

The new price structure won't be available till this magazine's gone to press but you can find it out by phoning the Dell Price Hotline on 0800 414535. Or send in the coupon right away.

Logical answers.

For applications that require the enhanced power and speed of a 80386 machine, there are now two logical answers – the Dell System 310 and the Dell System 325.

The System 310 has already established an enviable reputation. Fast and very reliable, it's become the standard by which other 386 machines are judged. And with its new three-bay chassis, it offers greatly enhanced storage capacity. Such as the option of mounting a tape streamer and two floppy drives.

The System 325 is a state-of-the-art PC which offers the highest available performing speed with greater expandability and enhanced capacity. Its specifications make it ideal for use as a powerful LAN server and for numerically intensive applications such as CAD/CAM and Artificial Intelligence.

Both machines are offered at prices that are highly competitive with comparable machines from companies of the calibre of IBM and Compaq.

Circle 98 on Reader Service Card

For the majority of business applications, the 80286-based Dell System 200 and System 220 still offer the most practical solution – and, now, even better value.

Giving you what you want.

Dell's reputation is built not only on powerful and high-performance products but excellent quality and compatibility. We aim to give the customer exactly what they're looking for – the best product, at the best price, with the best service and support package the industry can offer. And we can do that because of our direct relationship with the customer.

That's sound business sense and, in four years, it's made us one of the largest suppliers of PCs in the U.S. And, in the U.K., we're supplying Times Top 1000 companies and Public Sector Corporations, such as BP and HMSO, as well as individuals and small companies.

Accountability for life.

When you buy from Dell, you talk directly with the people who design and manufacture your machine. Every machine is configured to your requirements then rigorously tested before delivery. And the direct relationship continues with our support package. As often as you wish, you can get straight through on the Dell Technical Hotline to one of our experts.

If the solution needs on-site repairs, you're covered by the service agreement included in the price. This guarantees a visit by an engineer before the end of the next working day. And the limited warranty that comes with every Dell product covers both parts and labour.

Plus, there's our 30-day Guarantee of Complete Satisfaction. Should you be in any way unhappy with your purchase – we will refund your money in full.

Talk direct to Dell. Now.

There isn't room in this ad to tell the whole Dell story.

To answer all your questions about Dell, we've prepared a new information pack containing full details of Dell the company, the philosophy, full product specifications, prices and more. Send the coupon freepost for yours now.

But if you can't wait, why not put our direct relationship to the test, right away?

Phone our special Price Hotline on 0800 414535.

You can find out the best configuration for your needs and how it's going to cost you a lot less than you expected, even from Dell. And we pay for the call.

Dell System 325.

The premium Dell computer system featuring a 80386 microprocessor running at 25 MHz. The premium performance is achieved by the use of the Intel Cache Controller chip (82385), high speed (25 ns) cache memory, support of 80387 co-processor, support of high capacity-high speed (1:1) Interleave ESDI disk drives (up to 1.2 Gigabytes) and the ability to plug up to 16 MB of the DRAM into the main logic board. Suitable for use as a powerful LAN server and demanding applications such as CAD/CAM and DTP.

Dell System 220 – 20 MHz 80286 Performance.

"... a certain challenge to any of the current (and soon to be current) crop of 80386 SX machines in the speed stakes alone. And, given the quality of the unit itself, it's going to be around for some time."

EDITOR'S CHOICE, PERSONAL COMPUTER, SEPT. 1988.



Also available:

The 20 MHz, 80386 System 310.

The 12.5 MHz, 80286 System 200.

DELL COMPUTER CORPORATION

DELL COMPUTER CORPORATION, COOKHAM ROAD, BRACKNELL, BERKSHIRE RG12 1RD. TEL: 0344 860456.

0800 414535

Please send me your new information pack.

Return this coupon to Dell Computer Corporation, FREEPOST (RG 1462), Bracknell, Berkshire RG12 1BR or fax us on 0344 860187.

Name _____

Position _____

Company _____

Address _____

Postcode _____

Tel no: _____

B 11/88

MICROMINT'S Gold Standard in Single-Board Computers and Industrial Controllers

IMAGEWISE™ DT01 & DR01 Serial Video System

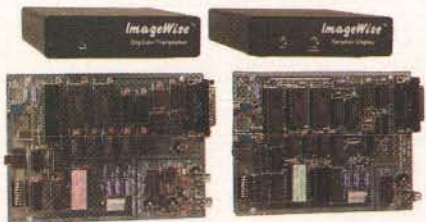

Micromint introduces a standalone SERIAL DIGITAL IMAGING SYSTEM. The Micromint IMAGEWISE Serial Digital Imaging System is the most cost-effective and versatile high-performance grayscale video digitizing system on the market today. The ImageWise system has been designed to function as a standalone digitizer or as an integral component of a complete tele-imaging system. ImageWise's serially bit-mapped digitized pictures give it almost universal compatibility with any computer capable of attaching to a modem or terminal. It is ideally suited for CAD/CAM, Desktop Publishing, automatic inspection, and security applications.

Critical system functions such as image resolution and picture update can be controlled and commanded remotely. Images are transmitted and received serially, either compressed or uncompressed, and can be displayed, transmitted, stored, edited, or processed for use in a variety of industry-standard applications software.

IMAGEWISE SYSTEM SPECIFICATIONS

- NOT bus dependent - can function standalone.
- True frame grabber - uses a high speed flash A/D converter and 64K bytes of static RAM to capture and image in 1/60th second.
- Accepts any B/W or color NTSC video signal.
- Stores pictures as 244 lines of 256 pixels, 64 level grayscale.
- Resolution of transmitted image is software selectable, all images are represented in 64 levels of gray scale.
- Selectable Resolutions:
High: 256x244x6
Med: 128x122x6
Low: 64x61x6
- Video Input: 1 volt peak-to-peak, B&W or color 75 ohm termination
- Video Output: 75 ohm, 1.5V peak-to-peak NTSC composite video
- Serial Input/Output: RS-232 - 8 bit, one stop bit, no parity 300 hps - 28.8 kbps selectable data rate - Xon/Xoff Handshaking switch selectable data compression (on/off).
- Modem compression: Easily functions as a video telephone to send video images anywhere.
- Video processing disk upload/download, and display utilities provided for PC-DOS and MS-DOS machines.

Optional PC Utilities Disk contains ImageWise files for use with popular Desktop Publishing and Paint Programs.

DT01	ImageWise Digitizer/Transmitter	\$349.00
DR01	ImageWise Receiver/Display	\$349.00
DT01/DR01	Combined Order Price	\$649.00

*OEM-286 \$620.00 Complete PC/AT-CPU

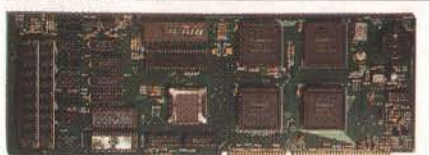

Low Power!
Expansion Card Form Factor!
100% AT Compatible!

Micromint's OEM-286, featured on the cover of the September 1987 issue of BYTE, is a complete PC/AT-CPU and more. The OEM-286 is a low-power, 100% AT-compatible CPU board which has been specifically designed for OEM use within the industrial and business sectors. The OEM-286 features the ZYMOCS CMOS POACH set and 100% compatible Award BIOS. The development of the POACH chip set has allowed the 129 ICs on a standard AT to be reduced to 20 ICs and two SIMMs. What this means for you is:

- 1) The overall size of a standard AT/PCU has been condensed into the expansion card form factor. (13 1/4" x 5 7/8")
- 2) Power requirements are less than 1 A @ 5 volts.
- 3) OEM-286 plugs into a passive backplane for easy connection to other expansion peripherals.

The OEM-286 is available in both 8 and 10 MHz versions and comes with the Award BIOS.

- * 100% AT compatible
- * 80286 Microprocessor, 8 or 10 MHz
- * 80287 Coprocessor optional
- * 64K bytes of ROM, can accommodate 128K bytes
- * 512K bytes of onboard RAM
- * Keyboard Controller
- * Award BIOS included
- * Expansion card form factor
- * Standard interface to the System Expansion Bus
- * Battery-backed real-time clock
- * Detachable mounting bracket

OEM-286/8 or OEM-286/10	8MHz or 10MHz AT/PCU	\$620.00
OEM-286BP	8 Slot passive backplane	\$115.00
	100 Quantity OEM price \$559	
	1000 Quantity OEM price \$495	

*SB180FX \$409.00 Single Board Computer

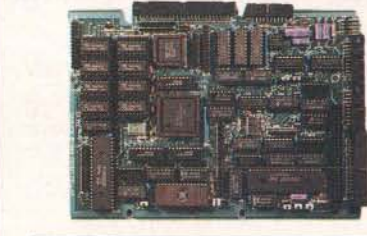

SB180FX TECHNICAL SPECIFICATIONS

- PROCESSOR**
- Hitachi HD64180, an 8-bit CPU in a 68-pin PLCC package
 - Superset of Z80 instruction set, including hardware multiply
 - Integrated Memory Management Unit with 32K bytes address space
 - Dynamic RAM refresh
 - Wait state generator
 - Clockless serial I/O port
 - 2-channel Direct Memory Access Controller
 - 2-channel Asynchronous Serial Communication Interface
 - 2-channel 16-bit Programmable Reload Timer
 - 12 interrupts
 - Dual bus interface to 68xx and 80xx support chips
 - 14MHz, 9.216MHz system operation
- MEMORY**
- 32K bytes dynamic RAM on board
 - Memory externally expandable to 8-Mbyte RAM
 - Either an 8K 2764, 16K 27128, or 32K 27256 EPROM usable
 - Full-function 8K ROM resident monitor
 - SOFTWARE
 - CP/M, ZRDOS, ZCPR3 compatible
- INPUT/OUTPUT**
- Console RS-232 serial port with autobaud rate select to 38,400 baud
 - Peripheral RS-232 serial port, full handshaking, 150-38,400 baud
 - Line printer parallel I/O port
 - 24 bit bidirectional parallel I/O
 - 19-bit address decoding, I/O port decoding, and dual bus interface brought out to expansion bus connector
 - Can be directly attached to GT180 640 x 480 color graphics adapter.
 - Fully implemented SCSI hard disk and communications bus interface
- FLOPPY/HARD DISK INTERFACE**
- Uses Standard Microsystems 9266 disk controller
 - Compatible with NEC 765A controller
 - On-chip digital data separator
 - Can control 3 1/2", 5 1/4", and 8" floppy disk drives - up to 4 in any combination
 - Handles both FM encoded (single density) and MFEM encoded (double density) data
 - NEC 52390 SCSI bus controller for hard disk or network communication

SB180FX-1 SB180FX 9.216-MHz computer board populated w/256K bytes RAM, 9K byte ROM monitor, without SCSI chip. \$409.00

SB180FX-1-30 SB180FX-1 computer board as described above with Z-System software including ZRDOS, ZCPR3, editor, utilities, ZAS assembler, and ZDM debugger, BIOS and ROM monitor sources, and BIOS for SCSI hard disk. Supplied on five 5 1/4" SB180 format DSDD disks. \$499.00

Additional 256K plus SCSI chip \$100.00
XBIOs upwardly compatible BIOS w/DateStamper \$75.00

SB180FX-1 OEM Configured 100 Quantity price \$315.00

*SB180FX-2MME \$319.00 Memory Expansion Board

Micromint is proud to introduce the SB180FX 2 Megabyte Memory Expansion Board. Measuring 5 3/4" x 8" the FX-2MME has been engineered to piggy-back on the SB180FX. A total of two FX-2MME boards can be stacked together to unlock the full potential of the SB180FX, and provide a maximum of 4 Megabytes of bank switched RAM. Board is fully socketed with 256K. Uses 120 nsec 256K x 1 Dram chips.

SB180FX-2MME 2Mb Memory Expansion Board w/256K \$319.00

*SB180 \$299.00 Single Board Computer

SB180-1 SB180 9.216-MHz single-board computer w/256K bytes RAM and ROM monitor. \$299.00

SB180-1-20 Same as above w/ZCPR3, ZRDOS, BIOS and ROM sources. \$399.00

COMMI180-S SCSI Hard Disk Interface \$150.00

XBIOs New Expanded Banked BIOS w/DateStamper \$75.00

SB180-1 OEM 100 Quantity Price \$195.00

SB180 Software and Accessories

SB180-U UniForm Disk Format Conversion Software \$69.95

SB180-ZMSG/TKBBS Z-MSG Bulletin Board Software \$100.00

SB180-CASE Four half-height 5 1/4" drive enclosure w/power supply, mounting brackets and hardware for the SB180 or SB180FX. \$197.00

SB180-CABLE Set of 4 cables including power, term, disk, and printer. \$79.00

XBIOs New expanded banked BIOS w/DateStamper \$75.00

*GT180 \$395.00 Graphics Display System for SB180/FX

The Micromint GT180 Color Graphics Expansion Board piggy-backs on top of either the SB180FX or SB180 computer boards and provides high-resolution graphics.

GT180-1 Graphic Display Expansion Board (TTL RGB only) \$395.00

GT180-2 Graphic Display Expansion Board (TTL RGB and Analog RGB) \$449.00

*PRICES SUBJECT TO INCREASE BASED ON CURRENT RAM PRICE. PLEASE CALL.

BCC180 \$395.00 Multitasking Controller

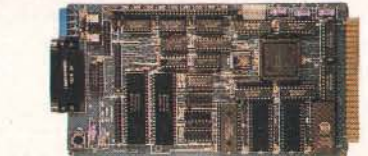

The BCC180, only 4.5" x 8.5", uses the same HD64180 CMOS Z80 instruction-compatible processor as Micromint's SB180 and SB180FX single-board computers. Configured primarily for process control w/384K of memory, 6 parallel I/O ports, console serial port, RS-232/422/485 selectable auxiliary serial port, and an interrupt-driven ROM-resident multitasking BASIC-180 compiler, the BCC180 uses the same 44-pin I/O expansion bus as Micromint's BCC52 controller board.

- PROCESSOR**
- * CMOS HD64180, 9.216MHz 8-bit CPU, 68-pin PLCC package
- MEMORY**
- * Up to 384K bytes total memory on-board
 - * 128K of either static RAM (62256) or EPROM (27256)
 - * 256K dynamic RAM SIMM
 - * Full-function 8K ROM monitor included
- INPUT/OUTPUT**
- * Console RS-232 serial port with auto baud rate select to 19,200 baud
 - * Peripheral serial port, 150-19,200 baud, selectable RS-232, RS-422, or RS-485
 - * 48 bit bidirectional parallel I/O
 - * 64K I/O available through the BCC bus edge connector
- DIMENSIONS and CONNECTIONS**
- * Dual 22-pin (0.156") edge connector
 - * Compatible with all Micromint BCC-series I/O expansion boards
 - * Two 26-pin headers for six bidirectional parallel ports
 - * 10-pin DB-25 for RS-232 console I/O
 - * 25-pin header for RS-232 auxiliary serial port
 - * 4 screw terminals for RS-422/485 connection

BCC180-1-20 9MHz assembled and fully socketed BCC180 Computer/Controller with 32K bytes of static RAM, ROM Monitor, BASIC-180 development software and user's manual. For Additional 256K DRAM add \$100.00 \$395.00

BCC180-1 100 Quantity w/32K RAM w/o ROM Monitor \$209.00

BCX \$59.00 X-10 Interface



X-10 (USA) Inc. has developed a new OEM AC powerline interface module. Using it in conjunction with off-the-shelf appliance and lamp control modules, computer systems can now remotely control AC-powered devices. Micromint has added the necessary software to use this control module with the BCC52, BCC180, and the IBM PC. Simply plug the X-10 AC interface module into any convenient outlet, connect the optional RJ-11 cable between it and the PC or BCC180/BCC52 and directly control any AC-line-powered device.

The software consists of subroutines, callable from high-level or assembly language, which execute the various permutations of ON, OFF, DIM, and BRIGHT commands. Software is supplied on EPROM (BCC180 and BCC52) or diskette (IBM PC) with both executable code and source code provided.

BCX/52	AC Interface Module and BCC52 software	\$59.00
	Item above with BCC52 cable	\$79.00
BCX/180	AC Interface Module and BCC180 software	\$59.00
	Item above with BCC180 cable	\$79.00
BCX/PC	AC Interface Module and IBM PC software	\$59.00
	Item above with IBM PC printer port cable	\$69.00

REPRESENTATIVES
ACCESS TECHNOLOGIES
1408 Richmond Dr
Placentia, CA 92670 Tel:(714) 996-3917

MICROFUTURE
41040 Cornac Terrace
Fremont, CA 94538 Tel:(415) 657-0264

DISTRIBUTOR
J.B. DESIGNS & TECHNOLOGIES LTD.
15 Market Place
Cirencester, Glos. GL7 2PB
England
Tel: 0285-68122 Fax: 0285-68859

To order call
1-800-635-3355

TEL: (203) 871-6170
TELEX: 643331
FAX: (203) 872-2204

MICROMINT INC.
4 PARK STREET
VERNON, CT 06066



We Guarantee Good News Every Monday Morning!



In fact, we'll guarantee the best news—100% factual, accurate and unbiased expert analysis of significant developments in the personal computer industry. Just straightforward, no-nonsense professional reporting of industry news, product announcements and key events *as they happen* each and every week.

BYTEweek, McGraw-Hill's new weekly newsletter, is devoted to helping you stay on top of the dramatic changes in the continually-evolving business computing arena. BYTEweek is devoted to reporting and analyzing these changes and developments through its timely, compact, one-stop news format. BYTEweek keeps you on top of significant industry trends and developments through its coverage of the IBM, IBM-compatible, Apple Macintosh and workstation markets. BYTEweek gives you the full details of significant new product announcements with in-depth analysis.

BYTEweek guarantees what no other personal computing publication can by building on two renowned and respected technical resources: the award-winning *Microbytes Daily* on-line news service and the technical expertise of the BYTE Editorial Staff aided by the new resources available to them in the recently expanded BYTE Lab. Through these resources, you are kept on top of issues such as:

- **New data storage techniques**, including CD-ROM, erasable optical and other text, graphics, and video storage technology.
- **Expert systems**, with an examination of both the technical and human aspects of implementation.
- **Bus standards** and the war between IBM and the clone manufacturers—with critically

important user ramifications.

- **Legal skirmishes** and "look and feel" suits, which can put the manufacturer of your favorite software out of business.
- **Software emulation** that will allow new, exotic computer systems to run software written for IBM PCs.
- **LAN system developments**, including all pertinent aspects of connectivity and inter-operability.
- **Network management**, a complex and increasingly important topic for personal computers in both small and large offices.
- **PostScript clones**, which promise faster, lower-cost laser printers with the same capabilities as the Apple LaserWriter.
- **New, easy-to-use programming systems** such as CASE and 4th Generation Languages, that can allow non-programmers to develop powerful applications.

BYTEweek offers you what no other industry publication can: timely news on the rapidly evolving computer industry *as it happens*, framed by interpretation and evaluation that only BYTE's experienced editorial staff can provide.

Subscribe now and take advantage of the special one-year charter subscription rate of **\$395** (\$495 outside the U.S. and Canada)—a *savings of \$100 off* the regular rate. Your subscription to BYTEweek includes 50 issues and a free subscription to BIX, which includes access to the award-winning *Microbytes Daily* on-line news service. Your hourly usage rates will be billed separately.

Don't miss this opportunity! Call BYTEweek's toll-free number:

1-800-258-5485

to order your subscription or request more information and a free sample issue.

BYTEWEEK

One Phoenix Mill Lane, Peterborough, NH 03458

1-800-258-5485

Charter subscription just \$395 for 50 weekly issues





The Promise of

A roundup of 10 packages reveals project management software's potential and its pitfalls

Lamont Wood

The concepts that underlie project management software have been around for decades. Only recently, however, have these concepts been moved to the microcomputer. Today, managers are increasingly embracing project management software for microcomputers. Some 100 packages are available. Functionality ranges from the trivial to the overwhelming, and prices

range from inexpensive shareware to products priced up to \$10,000.

Most project management software uses practices that were in circulation by World War I. They are, by and large, database programs with built-in workday and workweek calendars, producing charts that anybody who built ships in the Kaiser's war would feel at home reading. But they also use later techniques—like the CPM (critical path method), formulated by Du Pont and

Remington Rand Univac in the 1950s, and PERT (program evaluation and review technique) charts, developed by the U.S. Navy about the same time.

Some programs take the concept even further by providing a variety of features, like automatic resource leveling, a graphical interface, and interactive graphics displays. However, no package

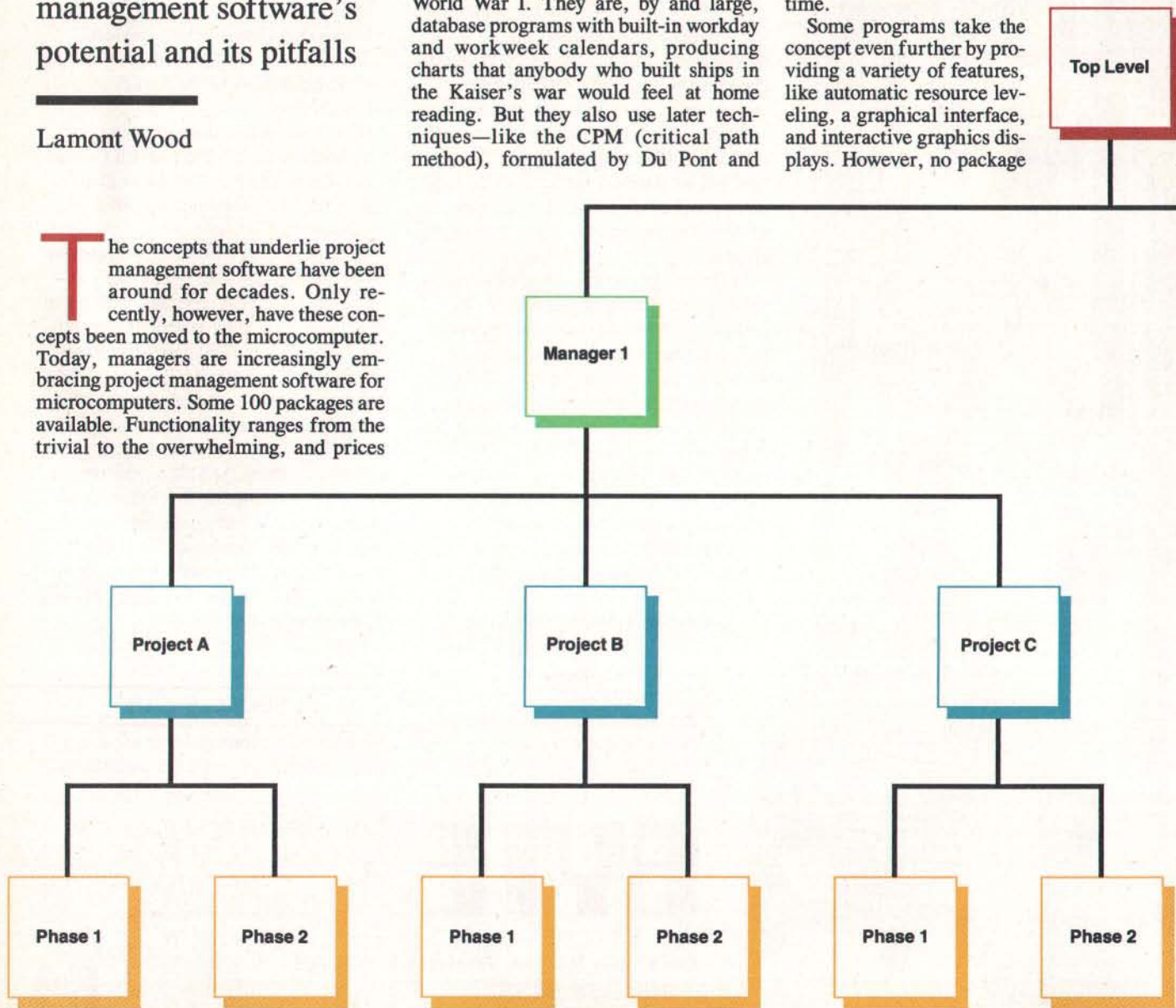

Project Management

now available offers an ideal mix of such features.

I examined a representative sampling of popular project management packages available for under \$2000. I tested 10 such packages. Due to the idiosyncratic nature of projects and the different techniques with which the packages input and manage information, across-the-board performance benchmarks would not provide meaningful results, and I didn't attempt any.

Major Considerations

Project management software isn't for everyone. The types of projects that these packages handle best are long-range group efforts with a definable beginning and end. Project management software is not designed for scheduling the coverage of daily chores, although you could probably trick some of these packages into doing so. An example of a suitable project commonly used by project management software vendors is the construc-

tion of a house. The construction of a nuclear submarine is a commonly used example of a complex project.

The advantage to using project management software is that it makes planning and updating easier as a project progresses. By contrast, with traditional paper tracking, you would need to log everything in and then redraw related charts and recalculate schedules. With project management software, you simply log in the update information and the program handles the rest automatically.

Planning and managing a project requires juggling tasks, resources, and time, and you must input relevant information for all three categories. The manner in which you enter this information varies from program to program. Tasks are the discrete activities into which you break up the project. Examples include pouring a foundation or framing the walls for a house. Resources include the labor, equipment, and materials needed for each task.

Some tasks must precede others, and you must define these relationships when you input project information. For example, you have to pour the foundation before you can frame the walls, and the walls must be up before you can start the roofing. If one task can start only after another ends, the relationship is categorized as finish-to-start. If both must start at the same time, then it's called start-to-start.

Once you've determined all the tasks involved to complete the project, it becomes obvious that the tasks follow in succession and that inter-

continued

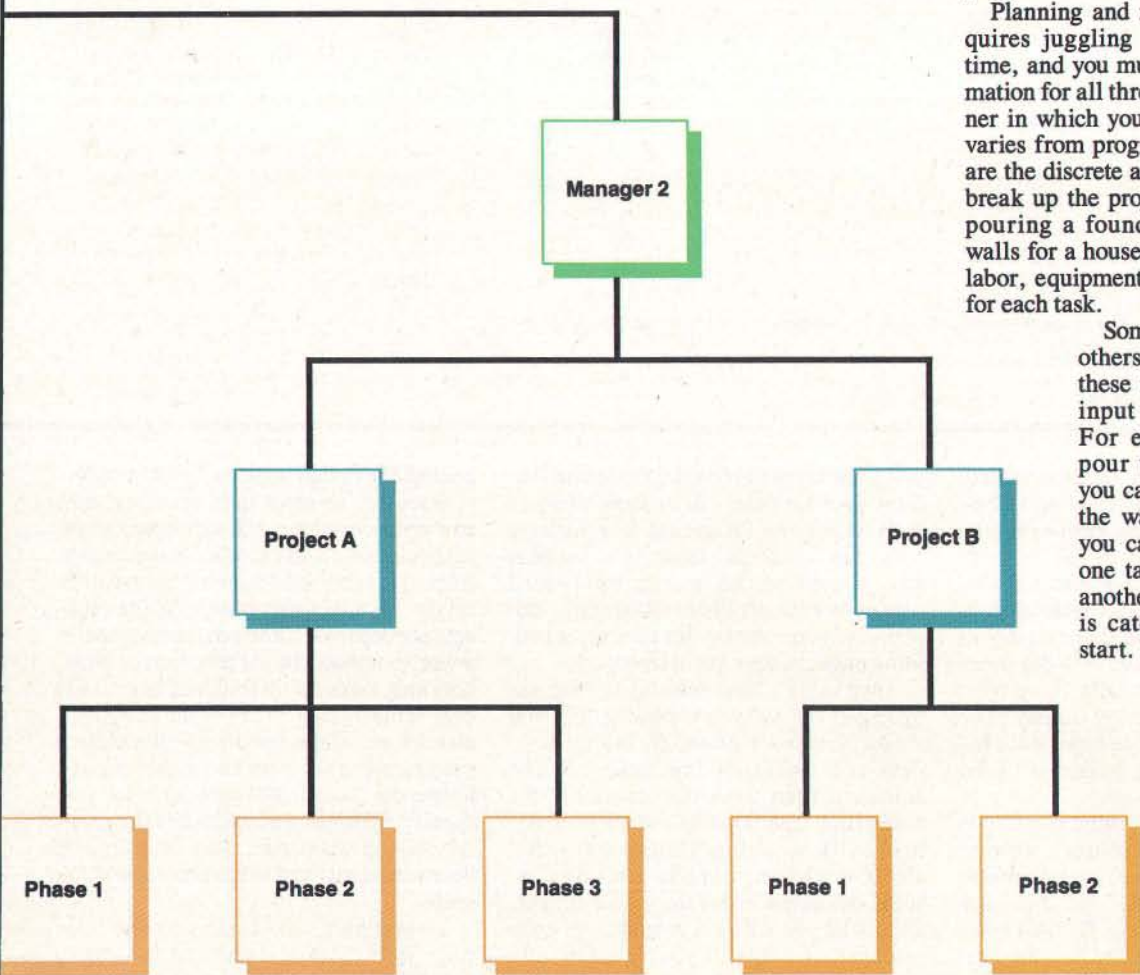

Table 1: Capabilities, features, and pricing vary widely among the 10 project management programs reviewed.

Product	Price	Disk format	Language	Minimum system requirements					Manual
				DOS version	Display	RAM	Disk drives	Hard disk space	
InstaPlan 1.03B	\$99	4 5/4-inch or 2 3/2-inch	C	2.11	Mono	512K	2 floppy or hard	1.2 M	162-page manual; 36-page PERT option guide
MicroTrak 1.6	\$595	2 5/4-inch or 2 3/2-inch	C	2.0	Mono	256K ³	1 floppy or hard	0.4 M	295 pages
Pertmaster Advance 2.0	\$1495	7 5/4-inch	C	2.0	Mono	320K	2 floppy or hard	2.1 M	372-page manual; 82-page tutorial
PMS-II 8.1	\$1295	4 5/4-inch or 2 3/2-inch	BASIC, C, assembly	2.1	Mono	512K	1 floppy, 1 hard	1 M	147-page user's guide; 90-page tutorial
Pro Path Plus 1.0 Level 26	\$495	3 5/4-inch	BASIC, assembly	2.1	Mono	384K	2 floppy or hard	1.1 M	267 pages
SuperProject Expert 1.0	\$695	4 5/4-inch or 2 3/2-inch	C	2.0	Mono	512K	2 floppy or hard	1.4 M	495-page manual; 36-page 10- minute guide
Time Line 3.0	\$595	4 5/4-inch	Modula-2	2.0	Mono	470K	Hard	1.9 M	300-page manual; 8-page getting started booklet
Timepiece 1.3	\$495	7 5/4-inch	C	2.0	CGA or Hercules mono	512K	1 floppy, 1 hard	0.7 M	276-page user's guide; 76-page tutorial; 15-page installation guide; 14-page product update
Topdown Project Planner 1.01	\$99	4 5/4-inch and 2 3/2-inch	C	2.11	CGA or Hercules mono ⁵	384K	2 floppy or hard	0.6 M	150 pages
ViewPoint 3.0	\$1995	6 5/4-inch	C	3.0	CGA	512K	1 floppy, 1 hard	0.8 M	408 pages

¹ T = time-scaled network diagram, G = Gantt, H = resource-distribution histogram, P = PERT, W = work breakdown structure.

² With no resources defined.

³ Additional 384K bytes needed with PlotTrak option.

⁴ With no tasks defined.

⁵ Requires optional \$40 driver software.

task relationships must be determined. The delay of one task may create a domino effect that delays the entire project. Such tasks form what is called the critical path. Other tasks are noncritical—unless they get excessively delayed. A 1-day delay in pouring the foundation will delay the project by 1 day. A 1-day delay in landscaping will not delay the project (although a 2-month delay might). The amount of delay a task can experience before it delays the whole project is called its float.

Resource planning, meanwhile, is complicated because resources come in discrete, finite quantities and also cost money. A carpenter, for instance, can work only 8 hours a day. To hold costs down, you'll want to schedule the carpentry work efficiently.

As you enter the resource information, some packages ask you to show whether each item has a fixed cost or a variable cost. For example, labor is a variable cost, since you can reduce the overall cost of it with efficient scheduling. But with fixed-cost items, like lumber, scheduling only changes the delivery date.

Then there's time scheduling. Project management software usually lets you define your own calendar, taking holidays and weekends into account. The software then uses this calendar for scheduling and plotting purposes, automatically working around days that aren't workdays. Simpler packages assume one calendar for the whole project. Others let you define a calendar for each resource, and they let you figure in individual vacations and even downtime ex-

pected due to bad weather, for example.

Once you've input task, resource, and cost considerations, the software should schedule tasks and calculate project costs automatically. All the programs in this review have this capability. As the project proceeds, all these programs provide a way to update the information to show how long tasks really took and how much they actually cost. Most of the programs also let you show variances—the difference between the plan and what actually happened. Some packages also let you specify multiple time estimates (i.e., optimistic, pessimistic, and most likely time scenarios) and make projections for each.

Surprisingly, one thing you don't always get is automatic resource leveling—the ability to schedule a project to make

Tasks	Maximum capabilities			Time scale	Task prioritizing	Automatic resource leveling	Variance tracking	Printer graphics	Charts supported ¹	User interface
	Resources	Calendars	Intertask relationships							
1400 ²	Limited by memory	1 per resource	Unlimited	Hours to years	○	●	Option	●	T, G, H, and others; P optional	Lotus-type menus
5000	Limited by disk space	1 per project	100 preceding, unlimited succeeding	Days to months	○	○	●	Option	T and G (optional)	Menu
1800	Limited by disk space	1 per resource, task, and project	1800	1/80 day to months	●	●	●	○	T, G, P, H, W, others	Lotus-type menus
3000	192	1 per project	1500	Days to months	●	○	●	Option	T, G, P, H, others	Menu
500	60	1 per project	10 preceding, unlimited succeeding	Quarter hours to years	○	●	●	○	G, P, H	Menu
1560 ²	1500 ⁴	1 per resource	Unlimited	Hours to years	●	●	●	●	T, G, P, H, W, calendars	Lotus-type menus
1000	300	1 per project	Unlimited	Minutes to months	●	●	●	Option	G, H, network diagram	Lotus-type menus
500	Limited by disk space	2 per project	Unlimited	Hours to years	○	○	●	●	T, G, H	Graphical
1500 ²	3000 ⁴	1 per resource	Unlimited	Hours to years	●	●	○	●	T, G, P, H, others	Graphical
Limited by disk space	Limited by disk space	10 per project	Unlimited	Days to years	●	●	●	Option	T, G, P, H, W	Graphical

●=Yes ○=No

tasks fit available resources and time. Some packages with automatic resource leveling also let you prioritize each task and use that information during automatic resource leveling.

While most of the programs require entering task relationships by typing in an ID number or a task name, some offer a graphical, point-and-shoot type of interface, which lets you draw connections on the screen using the arrow keys or a mouse. These packages tend to be more expensive, however.

Producing Charts

Whether scheduling is automatic or manual, the interaction of tasks, resources, and time gets complicated fast and is best tracked visually. A key feature of project management software is its ability to

generate a variety of printouts for this purpose. Each program generates a variety of charts that fall into the following broad categories:

- **Gantt charts:** Designed to help manage shipbuilding during World War I, Gantt charts represent tasks as horizontal shaded bars that are drawn to a common time scale (see photo 1). Usually, there's one task per row, and simultaneous tasks appear as bars stacked on top of one another. The course of events, when sorted by date, flows from the top left to the lower right. The method is named for its inventor, Henry Laurence Gantt.
- **PERT charts:** Created by the U.S. Navy to help in the design of the *Polaris* nuclear submarine, PERT is actually a technique incorporating the CPM. PERT

charts are project network diagrams that put each task in a box, with lines between boxes showing task relationships (see photo 2). Relationships, not scheduling, are the main concern here.

- **Time-scaled network diagrams:** These charts differ from vendor to vendor, but they are often the ultimate product of project management software, combining the concepts of PERT and Gantt. Tasks are shown in boxes laid out according to a time scale and connected by relationship lines. A heavy or double line usually denotes the critical path line.
- **Resource-distribution histograms:** These graphically show the demand for a particular resource over time (see photo 3). For example, you might plan to hire three carpenters on Wednesday, but the

continued

histogram may reveal that on Wednesday you'll need five carpenters to handle all the tasks scheduled for that day.

• Other plots: One example is a work breakdown structure (WBS), which arranges tasks graphically to present the structure of activities or cost accounts (see photo 4). These usually look like an organization chart.

What follows is an evaluation of the 10 project management programs I examined (see table 1). I ran them on an IBM PC AT clone using a 16-MHz 80386 CPU and Hercules monochrome graphics (except where color was mandatory) and running under MS-DOS 3.3. I tested printing capability with a Quadram QuadLaser emulating a Hewlett-Packard LaserJet, a Qume daisy-wheel printer, or an Epson dot-matrix printer, as each package required.

InstaPlan 1.03B

This \$99 package from InstaPlan Corp. requires two 5¼- or 3½-inch floppy disk drives and 512K bytes of RAM. Three options are available: a \$70 set of notepad utilities, a \$70 facility for tracking with variance reporting, and an \$80 PERT-chart generator. The review copy had the latter two options. While InstaPlan's base price seems low, many of the other packages include InstaPlan's optional functions. A fully configured version, at \$320, moves the program closer to the prices of other low-end packages.

InstaPlan uses a command interface reminiscent of Lotus 1-2-3 (e.g., pressing the Slash key brings up a command menu). Aside from the commands used for filling and editing the lists of tasks and resources, you can view the data as a

PERT chart, a Gantt chart, and a "load chart," or resource-distribution histogram.

The on-screen PERT chart is actually a three-tiered vertical WBS in a screen window (see photo 5). The task currently highlighted in the task list is in the middle of the window, with its predecessors boxed above it and its successors boxed below it. Critical path connections appear as double lines, and you can see more of the chart by scrolling through the list. The histogram highlights overload situations, where resource demand exceeds supply, and you can assign separate calendars to each resource.

After you've defined tasks and resources, the program assigns them to each other through what appears to be a spreadsheet—resources are displayed along the top, and tasks along the left side of the screen. At the cell where a resource and a task intersect, you can define the relationship. For example, where a carpenter resource and a framing task intersect, you might enter 8h/d for 8 hours daily. Costs for each task group and the project total are also shown on this screen, and these change as you define relationships.

InstaPlan includes automatic resource leveling, but you should use it only when you don't mind changing the completion date. You can tell this function not to change tasks on the critical path, or you can have it schedule a specified percent of available resources (using more than 100 percent lets you see what adding people would do to the schedule).

The optional tracking module lets you save your initial plan as a "reference plan," and then you can update the working version of the plan with ongoing com-

pletion data, using the spreadsheet view. Subsequent Gantt charts will then show the current plot and the baseline plot of each task, so that problem areas will stand out.

The PERT-module option prints beautiful charts, complete with a symbol key and even a "sign-off block," as is normally included in the corners of blueprints for an approval signature. The charts come out lengthwise on multiple sheets, which you reassemble.

The Gantt charts are equally handsome, although the bars are so large that only eight tasks fit on a page. Relationship lines also connect the bars in the Gantt chart. InstaPlan covers the basics, but it doesn't have task prioritizing and it doesn't support plotters. It also doesn't let you specify multiple time estimates, but neither do most packages in this price range. InstaPlan's low price and its high-quality printer graphics make it an excellent choice for those who can live without more advanced features.

MicroTrak 1.6

This \$595 package from SofTrak Systems requires a 5¼-inch or 3½-inch floppy disk drive and 256K bytes of RAM. To print network diagrams, however, you must buy a \$295 companion product called PlotTrak, which requires an additional 384K bytes of RAM.

High-priced multiuser versions of MicroTrak are also offered for Unix-based systems and for DEC minicomputers. The user interface shows the mark of the mainframe world—it's less flexible than InstaPlan and other programs. You fill in "fields" on the screen, and when you've filled all of them, the program asks if you want to edit the screen or go

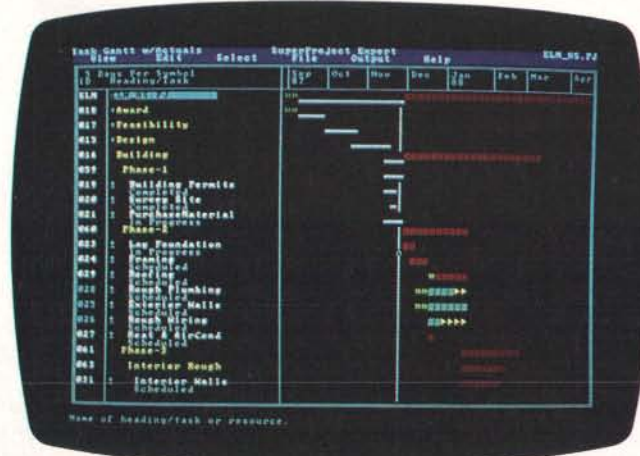

Photo 1: A Gantt chart generated by SuperProject Expert.

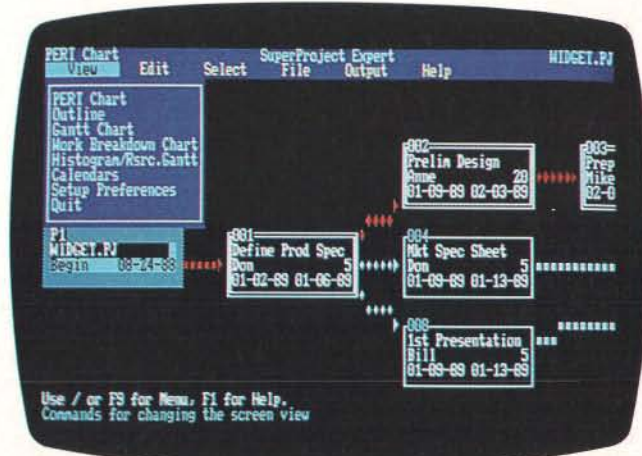

Photo 2: A typical PERT chart created with SuperProject Expert.

on to the next one.

MicroTrak doesn't support ASCII character graphics, and the time scale network diagrams that it produces are based on typewriter-style graphics that aren't terribly edifying. Likewise, the Logic Diagram Report, a PERT chart, is created with equal signs, minus signs, and periods. Printer graphics are available in the optional PlotTrak module.

Most of the output was in the form of tabular reports, with rows and columns of information and a variety of options as to what subject and how much detail to include. The Overuse/Underuse tabular report seemed to fill the niche usually filled by a resource-distribution histogram.

MicroTrak does not support automatic resource leveling. There is only one calendar for the whole project, and it's modified by simply listing the holidays. By contrast, other packages let you maneuver through an on-screen calendar grid.

PlotTrak lets you plot Gantt and PERT charts using a MicroTrak schedule, and it supports Hewlett-Packard, Ioline, Houston Instrument, CalComp, and Roland plotters.

MicroTrak is a program done by and for people who are at home in the mainframe world. Its interface, its price, and its all-or-nothing approach to graphics all reflect this. As a project management package, it provides bare-bones functionality. It has no automatic resource leveling, you can create only one calendar, and the user interface is crude.

Timepiece 1.3

The interface in Timepiece is more accommodating. It provides menus and input fields that change as you go along.

This package from Communications Dynamics, which costs \$495, requires a 5¼-inch floppy disk drive, a hard disk drive, a CGA or Hercules graphics display, and 512K bytes of RAM. It supports on-screen graphics and graphics printers, and it produced handsome graphs on my laser printer.

When inputting resource data in Timepiece, you update the default setting, which says, for example, "cost type: variable. \$500 per day. hours available per day: 8." If you change "variable" to "fixed," the rest of the field disappears, since it no longer applies. When defining tasks, you can assign resources to them as you go along, selecting them from a pop-up menu that shows which resources you previously listed.

Alternately, you can define the project by drawing a network chart on-screen, instead of listing the factors and having the computer draw the chart. You start with a chart on the screen showing Start, End, and a task box in between them. You can name and define multiple tasks, listing precedence relationships as you proceed, and Timepiece draws them in as you go along. While Timepiece adds tasks from left to right, you can nudge them up and down if the screen gets cluttered.

Timepiece supports only two calendars per project and has no automatic resource leveling. It can do variance reporting, but it won't allow multiple time estimates. For project reporting, there are 19 canned report formats, with various options and levels of detail. You also can update the plan with percentages, completion dates, and actual costs, so you can track an ongoing project.

Timepiece is undemanding—you don't

have to know much about the software to use it, and for that matter, you don't have to know much about project management. It seems aimed at middle managers who need to spend time where the actual work is happening rather than learning software and fiddling with schedules, and its graphical user interface makes Timepiece easy to use.

Pertmaster Advance 2.0

If Timepiece provides a good user interface, Pertmaster Advance raises project management nearly to the level of a video game. This British package from Projectronix demonstrates many things a project management package should do. Not only does it support automatic resource leveling, it also has a "nudging" feature.

At \$1495, Pertmaster Advance is a serious system for serious users—at a serious price. The program requires 320K bytes of RAM and two 5¼-inch floppy disk drives, although a hard disk drive is preferable.

Pertmaster Advance supports up to two graphs at once in half-screen windows (see photo 6). If you have, say, a resource-distribution histogram showing some overload, you can place it at the bottom of the screen. At the top of the screen, you open a Gantt chart showing only those tasks involving the overloaded resource. Then you set the two graphs to the same time scale with the same starting point, so that they track each other.

Next you can go into the Gantt chart and move one of the bars. This capability is unique among these packages—the software usually arranges the bars in response to your scheduling data. The tasks linked to that task rearrange them-

continued

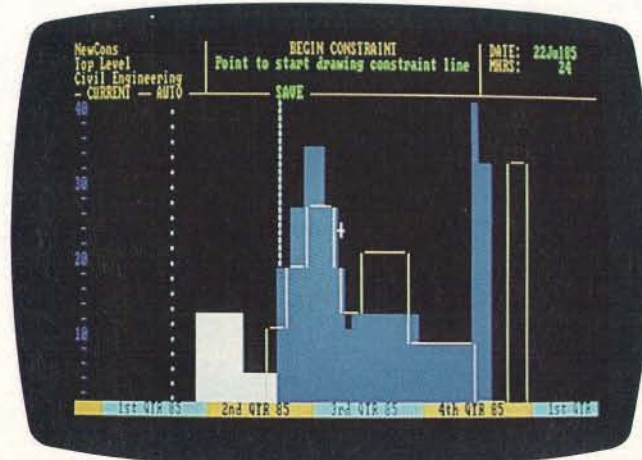

Photo 3: A resource-distribution histogram display in ViewPoint.

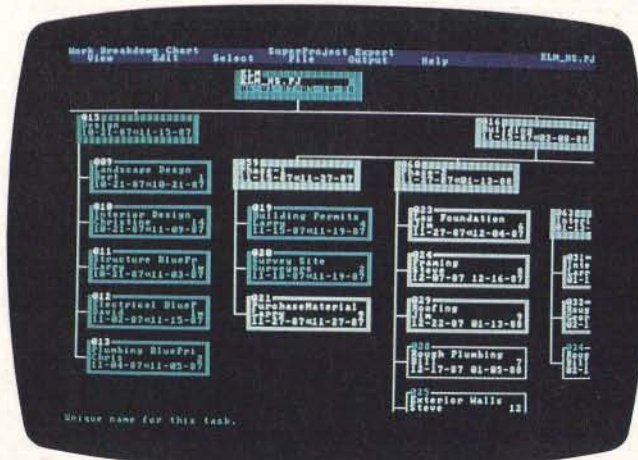

Photo 4: A work breakdown structure created with SuperProject Expert.

selves, and if you've affected the resource demand, the histogram changes. So you can move bars on the Gantt chart back and forth until the histogram no longer shows a problem.

An alternative is to trust Pertmaster Advance's resource-leveling "plan fit" command. If there is no required finish date, it can make everything fit. Otherwise, the program may leave some resources overcommitted.

You can assign separate calendars to each task and resource, and you can have resources and subresources. Examples include assigning workers to crews, trucks to crews, and drivers to trucks.

Pertmaster Advance can track ongoing projects and show variances. It also offers a mix of standard reports, including one numerical table that shows the demand for each resource on each day. But it doesn't let you create multiple time estimates.

The program is also rather weak when it comes to printing. Its reports are well organized, but charts are limited to typewriter-style graphics unless you have a CalComp, Hewlett-Packard, or Houston Instrument plotter.

PMS-II 8.1

If Pertmaster Advance is for the more serious user, PMS-II from North American MICA is for the full-time, dedicated user—the person who sits in a shipyard office and does nothing but scheduling. This orientation is reflected in the manual, which assumes some training with the software and familiarity with the world of project management. It limits itself to a general prose discussion of what needs to be done and how PMS-II accomplishes it. There is, however, a separate

on-line manual with specific directions on using the software.

PMS-II requires a 5¼-inch or 3½-inch floppy disk drive, a hard disk drive, and 512K bytes of RAM. By itself, PMS-II does task and resource scheduling only, and it costs \$1295. However, I also looked at six submodules, and the price for the entire combination is \$3695.

PMS-II's manual is refreshingly jargon-free, with discussions on "loading your hard disk" instead of "installation procedures." Even the on-screen messages are less stilted, like Please be patient while we figure this out.

The six submodules define the resource database, material delivery scheduling, graphics printer support, color plotter support, a report generator, and batch-processing macros for unattended operation.

The material-scheduling submodule—unique among the packages I reviewed—is designed not only to let you know when to order things, but to help pool orders to get the best quantity discounts.

You can define only one calendar per project. Each activity on the network diagram can have a text note appended to it recording your planning assumptions, interactions with contractors, or whatever you want. The report generator includes a database-type language with IF...THEN...ELSE logic to define report parameters. You can divide resource costs between general and administrative budgets.

Amid all its features, PMS-II makes no effort to achieve a sophisticated user interface—PMS-II worries about your data, not about you. And for a system with its price tag, you'd expect automatic resource leveling, but it's not there.

Pro Path Plus 1.0 Level 26

The main thrust of Pro Path Plus, a \$495 program from SoftCorp, seems to be to provide nicely formatted reports for use at morning progress meetings at an on-site construction office. It supplies the usual Gantt and PERT charts, but it also has reports that might be useful in a world inhabited by people more interested in precise pieces of information than in pretty charts.

Pro Path Plus uses a pop-up menu user interface, and it can produce reports on cash flow, project milestones, and expected completion dates. It also generates to-do lists and Gantt charts. You can reduce the time scale of the Gantt charts from yearly down to quarter-hour increments, with each character representing 15 minutes. On-screen, you can change the time scale by pressing the Plus or Minus key.

You can also create Gantt charts with one of three different time lengths for each task: the expected time, an optimistic time, and a pessimistic time. From these three values, it predicts a fourth, the duration you can expect within 50 percent accuracy, and produces a Gantt chart. It then prints a report with a list of possible completion dates for each task and the chance of finishing by that date. Printouts are limited to typewriter-style graphics, however.

Pro Path Plus does automatic resource leveling by delaying one or more tasks associated with an overloaded resource. On the Gantt chart, it marks the tasks it delays with one "r" symbol for each unit of time that it has delayed the task. If what you see on the chart confuses you, pressing F1 brings up a symbol legend.

continued

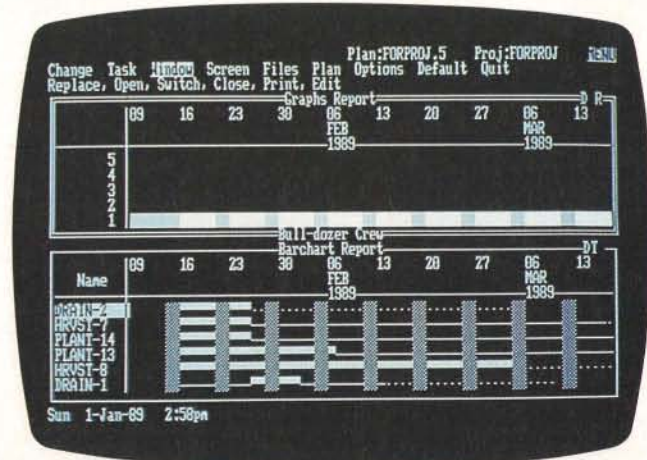
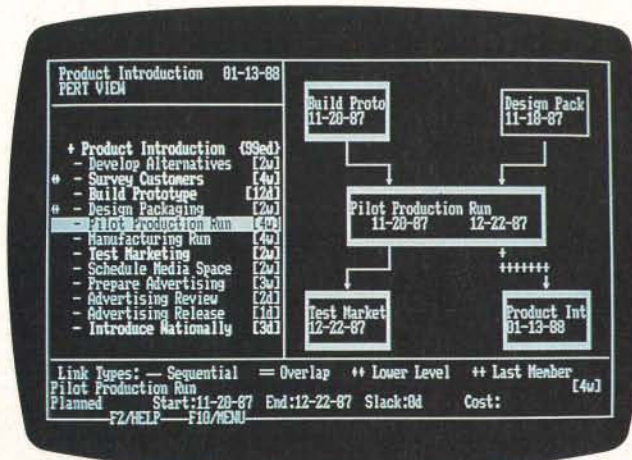
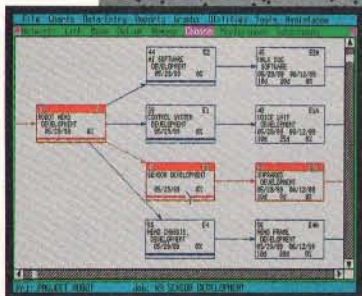

Photo 5: InstaPlan is less sophisticated than some other packages, but it's also one of the least expensive.

Photo 6: Pertmaster Advance lets you combine PERT charts and resource-distribution histograms on one screen.

"I brought the excitement back to project scheduling with a product that really works for you."

ROGER MEADE, PRESIDENT, SCITOR CORPORATION



Project Scheduler 4.TM The difference is graphically clear.TM

"Software products claiming to be #1 in project management aren't living up to their boasts. They have evolved by tacking new power features onto outdated versions at the expense of speed and usability. Their basic reports continue to be confusing and unreadable.

"I challenged my development team to reverse this trend and build a totally new product with unmatched speed, power, and ease-of-use. They met this challenge with Project Scheduler 4.

"Project Scheduler 4 is the first PC-based package that integrates high-resolution graphics with all the management tools you need. You understand more because you see more on the screen. At last, PERT and Gantt charts make sense. And responsibilities, deadlines, and resource bottlenecks are all spotted at a glance.

"You see more on paper, too. Project Scheduler 4 gives you beautiful, graphic reports that don't require tedious cut-and-paste assembly. They're instantly understandable. Not to mention simple to

generate for impressive presentations.

"Because scheduling is primarily a visual process, Project Scheduler 4 uses an intuitive, graphic interface that gives you a clear view of the big picture. Gone are hard-to-remember commands and keystroke sequences. Here is the future of advanced productivity tools.

"A project scheduler should help you manage your time, not waste it. Project Scheduler 4 is fast. In fact, it's much faster

than most character-based systems. Its tremendous power is provided with ease and elegance. In other words, it's a project scheduler that really works for you."

When your time is on the line, you should be using Project Scheduler 4. Call 415 570-7700 for more information and a free brochure.

 Scitor
Corporation



Playing what-if games with resources is difficult because there is no central list of them—resources exist only by being listed under a particular task.

Pro Path Plus is a limited package designed for middle-level managers, for whom fiddling with charts and computers is a secondary concern.

SuperProject Expert 1.0

SuperProject from Computer Associates International is available in high-end Expert (\$695) and low-end Plus (\$395) versions. I reviewed SuperProject Expert; SuperProject Plus is similar to Expert, but it lacks automatic resource leveling, probability scheduling, and graphics printing.

Like Lotus 1-2-3, SuperProject Expert uses the Slash key to invoke a command menu. You select options, like what chart to display, from pop-up menus. You can also compile project information in an "outline" screen, and you can switch from there to a Gantt chart, PERT chart, WBS, or resource-distribution histogram. The PERT-chart screen is somewhat interactive—you can "scroll" from one task to another with the arrow keys, and pertinent information for that task appears in a pop-up box. You can also change this information on the fly and thus edit the chart as you go along.

Each chart's scale is changeable. This includes changing not only the time scale in a Gantt chart, but also the size of each task box in a PERT chart. You can reduce the size of the boxes until there is only enough room for the task ID number, making more of the project visible on the display.

You can also specify optimistic, pessimistic, and likely durations and output them in Gantt-chart format. With this option, the software calculates the expected duration (i.e., the optimistic, the pessimistic, and four times the likely duration, divided by 6), which it then uses for most other calculations.

When tracking a project's progress, each task can have six different conditions: scheduled for the future, started late, in progress, interrupted, completed, and finished late. The program does automatic resource leveling and can report variances. Also, you can have a separate calendar for the project and one for each resource. SuperProject Expert also includes a macro language that automates repetitive tasks or lets you set up unattended batch processing.

Printer facilities include Sideways, a utility that outputs charts in landscape mode. Charts generated using Sideways

support graphics printing. On a laser printer, SuperProject Expert produced handsome PERT charts, but they lacked the accompanying symbols, legends, titles, and frames produced by the other packages.

Like most of the other packages, SuperProject Expert makes no effort to use a graphical interface. You enter data by filling out lists and fields. Other than that, however, there's little else you could ask for amidst its barrage of options and features. For the price, it's one of the best deals in the group.

Time Line 3.0

This \$595 package from Symantec requires a hard disk drive and 470K bytes of RAM. A \$195 graphics option makes presentation-quality charts on Hewlett-Packard, Houston Instrument, and Roland plotters. The basic package produces typewriter-style graphics.

Time Line's eye-appealing packaging gives it away: This is product management software for the mass market. The documentation is lucid and stocked with examples, the user interface is polished, and great attention has been paid to some carefully selected features, to the exclusion of some others.

The program displays a network diagram that is a variation on the standard PERT chart. Time Line organizes tasks as "summary tasks" composed of sub-tasks. Each summary task is in a large box that contains subtask boxes, and the summary task boxes are connected by precedence lines. Each subtask can also have tasks under it, and charts quickly become complicated. Projects can end up looking like a complicated nest of boxes that's bothersome to decipher.

Also, while Time Line does calculate the critical path, you can highlight only the boxes, not the precedence lines, on the critical path. To do so, you must use a "filter."

Time Line does not have a time-scaled network diagram, but it does have a Gantt chart that includes coded information to the right of each task name, indicating whether a task is on the critical path or has an overscheduling problem. You can scroll around in the chart by using the arrow keys, but you can't nudge the bars—they are placed according to the information you give in various data input screens.

Time Line can also display resource-distribution histograms, but only in combination with a Gantt chart. You can show up to five histograms on the bottom of a Gantt chart, set to the same time scale, and you can print out these com-

bined charts. Resources that are over-scheduled are highlighted. Time Line can also perform automatic resource leveling.

The number of reports available is not extensive. It can do status reports, showing what tasks occur in a specified week or month; cross tab reports, showing expenses involved in a particular task (or resource) in a specified time frame; and resource reports, whose columns contain whatever data fields you specify.

The Lotus 1-2-3-like user interface includes numerous shortcuts using the function keys. You can conveniently select items (like when you assign a resource to a task) using a variation of the point-and-shoot method from pop-up screens.

The manual assumes the reader has no background knowledge of project management, and it carefully introduces new concepts like critical path and fixed cost. There is a lengthy on-line tutorial that's too simple. And when you run the program for the first time, Time Line gives you special "First Aid" screens that help you create a schedule. Also, contextual help screens that you can invoke with F1 are thorough.

Time Line uses a lot of memory and relies a great deal on disk swapping. The only time this proved to be a problem was when it produced a network diagram—a project with 50 tasks took 3 minutes, even on a 16-MHz 80386 machine.

Time Line is a slick, simplified version of SuperProject Expert. Both work from an outline task list, but Time Line adds a comforting cocoon of help screens and tutorials. It lacks some extras, like multiple time estimates, a time-scaled network diagram, multiple calendars, and more extensive report formats.

On the other hand, because of its copious help features and plain-language documentation, it can be safely placed in the hands of someone who is approaching computer-aided software management for the first time.

Topdown Project Planner 1.01

Topdown Project Planner from Ajida Technologies is a \$99 package that requires 384K bytes of RAM, two floppy disk drives, and a color graphics display. The program is based on a descending hierarchy of PERT charts, each covering one screen. You define the main tasks by placing, defining, and connecting PERT boxes on the initial screen, using the program's graphical interface. Then you go into each box, where you start over with a blank screen and define the tasks that go into the main task. This continues for

continued

"InstaPlan can help you drain a swamp before the alligators get out of hand."

— Woody Liswood
PC World*



Introducing InstaPlan 2.0.

InstaPlan has gained a reputation as the easiest project planner to use, the fastest to learn and the least expensive to own. It introduced outlining technology for quick planning and proposal writing. Now, InstaPlan 2.0 delivers more planning power, plus state-of-the-art management, documentation and presentation facilities. With no increase in price.

Plan With Power.

InstaPlan 2.0 does single project, multiproject, open ended and deadline scheduling. It uses individual resource calendars for realism. And it lets you evolve your plans quickly with Move, Copy, and Append functions, and a work assignment spreadsheet.

The InstaPlan 2.0 NotePad Option allows you to document every activity, resource and work assignment in your plans. It's an electronic logbook to keep you better organized.

Manage With Perspective.

If you have a team with too many projects and too little time, InstaPlan 2.0 is perfect for you.

The InstaPlan 2.0 Advanced Tracking Option keeps a detailed history of your manpower, spending and progress. Conventional products record only the latest status and forget the past. Whenever you want to know who did what, whether for last week or three months ago, InstaPlan will display a table, spreadsheet or graph in seconds. With this information at your fingertips, you can make better commitments, recognize troublesome trends and provide knowledgeable explanations without digging through piles of old printouts.

Advanced Tracking Option incorporates % progress, in-progress actuals, five-way earned value, full C/SSR reporting, manual and automatic forecasting. Plus on-screen spreadsheets of actuals, work remaining, earned value and variances for any period of time - capabilities that other products simply don't have.

Communicate With Clarity.

InstaPlan's integrated Gantt-PERT diagrams communicate better than ordinary charts. They show both time and sequence clarity in page or wall sized formats. New report formats provide detailed "to do" plans for individuals for any time period and spreadsheets.

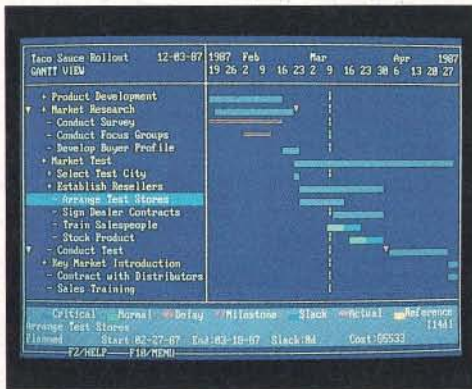

Purchase With Confidence.

InstaPlan is sold with an unconditional 30 day money back guarantee. We provide excellent applications support at no additional charge.

- InstaPlan Standard Product**
- 600 activity capacity (640K RAM)
 - Activity and resource outlines (WBS/OBS)
 - Individual resource calendars
 - Duration and resource driven planning
 - Resource leveling and smoothing
 - True multiproject operation
 - Gantt-PERT, tabular and resource graphs
 - Data transfer to 1-2-3™ / dBase III™ / Ascii
 - Users manual and tutorial
 - Extensive on-screen context sensitive help

Advanced Tracking Option

- Integrated with views and reports
- In-progress entry of man hours and cost
- Automatic forecasting using progress to date
- Automatic history recording & interpretation
- % progress, earned value by task and group
- C/SSR for activity, resource and period
- Baseline variance for time, budget and hours
- Actual, remaining, earned displays by period
- Import progress and actuals from files

NotePad Option

- Windowed word processor and calculator
- 8000 characters/note; unlimited notes/plan
- Categorization; integration with reports

800-852-7526

Recommended Configuration: IBM PC/XT/AT/PS2 or compatible, 640K RAM Hard Disk.
Printers Supported: IBM Proprinter & Graphics Printer, Epson FX/MX/RX/LQ, Okidata Plug'n Play 92/3, Microline 192/3, 292/3, Toshiba 351 and HP Laserjet+/Series II/Deskjet.

*Used with PC World's permission.

InstaPlan 2.0 \$99

InstaPlan Corporation, 655 Redwood Highway, Suite 311F, Mill Valley, CA 94941 (415) 389-1414

- Send me InstaPlan 2.0. **\$99**
- Send InstaPlan with Tracking Option. **\$169**
- Send InstaPlan with Tracking and NotePad Options. **\$239**

Add \$6 shipping and handling. \$10 Canada. \$25 International. California Residents, add 6% Sales Tax.

- Send me more information on InstaPlan.
- Check enclosed Visa MasterCard American Express

Card # _____ Expires: _____
Signature _____
Name _____
Company _____
Address _____ Phone _____
City _____ State _____ Zip _____

Not copy protected. Site licensing available.

Company Information

Ajida Technologies, Inc.

613 Fourth St.
Santa Rosa, CA 95404
(707) 545-7777
Inquiry 952.

Communications Dynamics

7300 Southwest Hunziker, Suite 200
Tigard, OR 97223
(503) 684-5151
Inquiry 951.

Computer Aided Management

1318 Redwood Way, Suite 210
Petaluma, CA 94952
(707) 795-4100
Inquiry 953.

Computer Associates International, Inc.

2195 Fortune Dr.
San Jose, CA 95131
(408) 432-1727
Inquiry 949.

InstaPlan Corp.

655 Redwood City, Suite 311
Mill Valley, CA 94941
(415) 389-1414
Inquiry 944.

North American MICA, Inc.

11772 Sorrento Valley Rd.
Suite 257
San Diego, CA 92121
(619) 792-1012
Inquiry 947.

Projectronix, Inc.

4546 El Camino Real, Suite 324
Los Altos, CA 94022
(415) 966-1527
Inquiry 946.

SoftCorp, Inc.

2340 State Rd. 580, Suite 244
Clearwater, FL 34623
(813) 799-3984
Inquiry 948.

SofTrak Systems, Inc.

1574 West 1700 South, Suite 2C
P.O. Box 16750
Salt Lake City, UT 84116
(801) 973-9610
Inquiry 945.

Symantec Corp.

10201 Torre Ave.
Cupertino, CA 95014
(408) 253-9600
Inquiry 950.

ViewPoint 3.0

ViewPoint from Computer Aided Management is one of the higher-priced packages in the group, but it also offers the most features. It costs \$1995, but I also tested its graphics printing and plotting option, which costs \$995. The program requires a floppy disk drive, a hard disk drive, and a color monitor.

When you start defining a project in ViewPoint, you see a screen with a blank work area and a cross-hair cursor that you can move with a mouse or cursor movement keys. The date counter in the corner moves forward as the cursor moves right, and backward as it moves left. You move the cursor to a likely date, press the Plus key on the numeric keypad, and up pops a window. Press T, for task, and a "task description window" pops up. You fill in the information, and a box representing that task appears on-screen.

After entering a few tasks, you assign precedences by drawing lines between the boxes. To establish a finish-to-start relation, you draw from the right (finish side) of the first box to the left (start side) of the other. If the new line is part of the critical path, the line appears in red.

If the precedence relations (and duration of the preceding tasks) indicate that a task should start at some time different than its original placement, ViewPoint may relocate the box after you draw the lines. You can also change the time scale to view more of the project on-screen. The larger the time scale, however, the smaller the boxes get; task names may be truncated beyond recognition.

You can play with the layout of the network and with the task data until you get what you want. After you define a list of resources, you can assign them to tasks by a simple point-and-shoot method: You highlight the task, call up the pop-up resource list, and highlight the resource.

You can also "constrain" resources graphically. On the resource-distribution histogram, you can draw a line at whatever level you want to limit the resource to. You can move the line up and down as you go left to right, reflecting any changes you expect. ViewPoint then does resource leveling, changing the end date or eating up the available float to push tasks to a point on the time line where they can get the resource they need.

The new schedule is labeled "pending" until you decide to accept it. "Negative float" may appear on the new schedule—meaning the software has moved the start of some tasks forward to level resources.

The program's constrain function also

continued

as deep as you want to go, within ordinary memory limitations.

You can go into a screen mode that shows the boxes without any text. In this mode, you can see, drawn in miniature within the boxes, the charts for the next level. Perhaps mercifully, you can't see to the third level.

You can assign tasks priorities, and automatic resource leveling is available, although you can't perform variance tracking. The latter works by delaying tasks with lower priorities. The manual suggests resolving obvious conflicts by assigning priorities and then letting the computer take over, but it warns that resource leveling should be used with care because it can cause major rescheduling for noncritical tasks. In the real world, such changes can make a schedule difficult to implement. Automatic resource leveling is still useful, however, as long as you make provisions for making some

manual adjustments.

Topdown Project Planner can combine two graphs on one page, like a Gantt chart on top of a cumulative cost chart, and can set both to the same time scale. You could also have a Gantt chart with a daily cost projection below it, for budgeting purposes, or a Gantt chart with a histogram below it, so you could spot overloads and immediately see the source. Printouts are essentially screen displays scaled to fit a page, and they require a graphics printer.

The program also lets you track progress on a project, and the Gantt charts reflect what has been done. You also can assign a calendar to each resource and append text notes to each task on-screen. The only thing I didn't like is that Topdown Project Planner limits each PERT chart to one screen. By contrast, other programs let you create charts that are bigger than your display.

STATGRAPHICS®

New Version—2.6
Upgrades Available

INCOME VS SAVINGS ANALYSIS
VIA INTERACTIVE OUTLIER REGRESSION

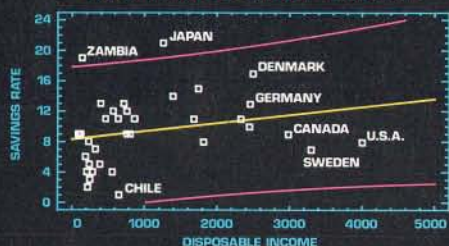

BO: 8.304 SE: 1.1173 T: 7.4321
B1: 1.0655E-3 SE: 7.4902E-4 T: 1.4225
CORR: 0.24036 MSE: 20.651 DF: 33
POINTS DELETED:

INCOME VS SAVINGS ANALYSIS
VIA INTERACTIVE OUTLIER REGRESSION

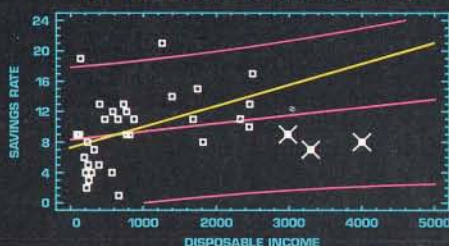

BO: 7.1962 SE: 1.1736 T: 6.4319
B1: 2.7801E-3 SE: 1.0234E-3 T: 2.7166
CORR: 0.44433 MSE: 19.147 DF: 30
POINTS DELETED: CANADA, SWEDEN, U.S.A

Select the points you want to remove from your regression model...

... Then press F6 to refit the model and recalculate the statistics.

Because "Statistical Graphics" Is Better Than Just Statistics and Graphics

Most of today's PC statistical packages give you all the statistics you'll ever need. Some even give you a few graphics. But only STATGRAPHICS from STSC gives you integrated statistical graphics in an environment you control.

Unique "What If" Interactivity

STATGRAPHICS lets you explore data relationships fully, producing higher quality, more timely solutions. Define your data and assumptions, run the procedure and review the results, modify data and assumptions repeatedly and take another look—and another. All without leaving the procedure or making permanent changes to your data.

Integrated Statistical Graphics

Coupled with STATGRAPHICS' interactive environment are over 50 types of graphs—traditional pie and bar charts, histograms, 3-D line and surface plots, quality control charts, and more. All are integrated with the procedures so that they can be displayed instantly and modified repeatedly.

Query data points, do on-screen forecasting and model fitting, overlay graphs, or zoom-in on any area for a closer look. With flexibility like that, you can spot and investigate visual trends in your data—trends you may have missed if you looked only at the numbers.

Over 250 Statistical Procedures

- Direct Lotus® and dBASE® interfaces
- ANOVA and regression analysis
- Experimental design
- Quality control procedures
- Multivariate techniques
- Nonparametric methods
- Exploratory data analysis
- Forecasting, time series analysis, and more.

STATGRAPHICS—

The Best Way to Do Statistics!

Put the power of STATGRAPHICS to work for you today—all for only \$895*. For our free convincer kit or the name of a dealer near you, call

(800) 592-0050 ext. 400

In Maryland, (301) 984-5123;
Internationally, (301) 984-5412.
Telex 898085 STSC ROVE

See us at COMDEX—
Booth H7416

STSC STSC, Inc.
2115 East Jefferson Street
Rockville, Maryland 20852

*Suggested retail price in U.S. and Canada. International prices vary. Available through dealers and distributors worldwide. STATGRAPHICS, Lotus, and dBASE are registered trademarks of Statistical Graphics Corporation, Lotus Development Corporation, and Ashton-Tate, respectively.

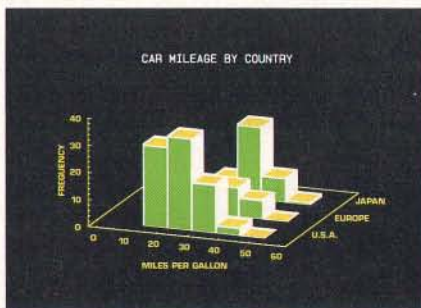
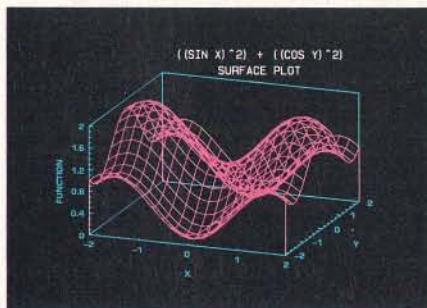

A wide variety of graphs supported on over 100 displays, printers and plotters, including the new IBM PS/2™ Series.

Circle 318 on Reader Service Card

NOVEMBER 1988 • BYTE 191

prevents expenses from rising above a specified daily level, since you can draw a constraint line on the cost histogram.

To measure a project's progress, you make a "snapshot" of your original "reference plan," which thereafter appears as pale blue lines placed over white bars that represent progress. ViewPoint offers a full range of report options, and the printer-graphics option generates Gantt, PERT, WBS, and other project network charts.

ViewPoint comes across as both fun and powerful—a rare combination. Unfortunately, it's also expensive. Many other packages provide most of the functionality for substantially less money.

Overview

All the packages reviewed here could help you manage a project with varying degrees of depth and sophistication. But many of them lack a good user interface, and some offer only basic project man-

agement capabilities. MicroTrak, for example, does little more than the on-screen equivalent of paper modeling, although it's faster than manual methods once you've entered the data. Most of the others make an effort to break with the past and make use of the computer's power, like Pertmaster Advance, with its nudging function, and ViewPoint, with its ability to let you graphically build and interact with a network diagram on the screen. Topdown Project Planner and Timepiece have similar functions, but they aren't so sophisticated.

Another consideration is whether you need project management software at all. Ultimately, a project must be of a large enough scale to benefit from project management software. How many tasks should you have before project management software becomes worthwhile? The answer depends on the manager and the project. You may find the software helpful for tracking as few as 20 tasks, if frequent updates are required; others may find manual methods easier until a project requires tracking 100 or more tasks.

While many of these packages have one or two attractive features, none has all of them in one package. The optimal package would be a combination of Pertmaster Advance and ViewPoint, which would involve a graphical point-and-shoot interface, automatic resource leveling, and manual editing capability using the graphics interface. Unfortunately, such a program doesn't exist.

Of these 10 programs, which is best depends on your needs. If you want support tools for managers who would otherwise keep everything in their heads, something like InstaPlan will do the job for a reasonable price. If you're trying to ease the burden for someone who spends many long hours trying to squeeze the last bit of fat out of a high-cost project, Pertmaster Advance or ViewPoint would be desirable. Good compromises are SuperProject Expert and Topdown Project Planner, which offer much of the capability of the high-end packages at more reasonable prices. ■

ACKNOWLEDGMENT

I wish to thank Daniel Yahdav, president of the consulting firm 1 Soft Decision, Inc., who provided input for this review. His firm publishes PM Solutions, a comprehensive report on project management software.

Lamont Wood is a freelance writer in the computer and electronics fields who lives in San Antonio, Texas. You can reach him on BIX as "lwood."

A HOLMES IN EVERY PORT



ARRIVING AT COMM. PORT 2 The Best Laptop Modem

(John C. Dvorak — P.C. Magazine)

...At an Affordable Price. (P.C. World)

All Holmes Correspondent™ Modems are fully Hayes™ compatible. They include auto answer, auto dial, and use very little power. These features, along with a two year warranty and a complete software package make Holmes the best value available.

HOLMES
MICROSYSTEMS, INC.

1-800-443-3034

WE'VE GOT THE MODEM FOR YOUR LAPTOP!



Six ~~Five~~ easy ways to boost your BASIC

PROBAS™ ^{updated} Professional Basic Programming Library

Announcing PROBAS Version 3.0, now with over 335 assembly routines to really kick QuickBASIC and BASCOM into high gear. BYTE magazine calls PROBAS a "Super-charger for QuickBASIC". Thousands of programmers rely on PROBAS to make their life easier and to enhance their programs with features like:

- An 800-page 3-part manual
- Full-featured windowing
- Screen snapshots (Text & Graphics)
- String, array, and pointer sorts
- Lightning-fast file I/O
- Full mouse support

Create dazzling screens in text mode, CGA, EGA, VGA or Hercules graphic modes. Save and restore screen snapshots to arrays, EMS memory or files. Full featured windowing to meet the most demanding jobs. The PROBAS system of virtual screens allows you to draw full or partial screens to memory, and then snap them on in an eyeblink. You can even create virtual screens far larger than the display screen.

Sick of running out of string space? Store hundreds of K in numeric arrays or megabytes in extended or expanded memory. Tired of using a kludgy SHELL to DIR to read a directory or archive files? Scan sub-directories or .ARC files using wild-cards and store thousands of file names, dates, and times. Wish you could drag a window containing text or a menu around the screen with a mouse? It's easy!

PROBAS gives you a complete set of blazingly-fast file routines. Read or write huge chunks of data at a clip, with file locking and error handling so that you can even use them in subprograms. You'll never want to use BASIC's file I/O again! Sort data with lightning fast array and pointer sorts. Search files or arrays at assembly speeds. PROBAS also has over 200 other essential services including handy string, date, time, directory and array manipulation, string, screen and data compression, full mouse support, valuable equipment and input routines and faster replacements for most BASIC commands.

Whether you are a professional or a novice, PROBAS will boost your BASIC in ways you never dreamt possible. PROBAS allows professionals to save time and work and lets novices write professional-quality programs quickly and easily. After all, how much is a few hundred hours of your time really worth?

For all versions of QuickBASIC and BASCOM including BASCOM 6.0 for OS/2. **Just \$135.00!**

PROREF™ On-Line Help For PROBAS

PROREF provides pop-up help for the routines in PROBAS and is an extension of the QuickBASIC programming environment. Find help on any routine with a few keystrokes or mouse clicks. Pop-up an ASCII chart, calculator, scan code module, box diagram, your own help information or almost any DOS program via a hot-key. **Just \$50.00!**

PROSCREEN™ Professional Screen Management System

PROSCREEN is a full-featured screen generator/editor that will save you more design and coding time than you ever thought possible. PROSCREEN treats screens like a word processor treats text to provide complete control over characters, colors, and placement. Design input screens with up to 130 fields and 19 pre-defined and 2 user-defined masks. Use PROBAS or the included BASIC/Assembler subroutines to access the screens. No kludgy code generators here! Comes with subroutine source, extensive on-line help, and a 285 page manual. **Just \$99.00!**

PROMATH™ ^{new!}

PROMATH is a collection of over 150 high-level routines that provide mathematical functions and operations for programmers who often work in mathematics, science, or engineering. Complex variables, real and complex matrices, real and complex trigonometric and hyperbolic functions and their inverses, solution of linear equations, integration, differential equations, Fast Fourier transforms and many other useful routines are provided.

For years Fortran has been the language of choice for scientific and engineering applications, but it lacks many of the useful features of QuickBASIC. PROMATH contains most of the Fortran mathematical and numeric functions and allows you to easily translate Fortran code to BASIC or write new programs in BASIC while retaining Fortran's numerical prowess.

The PROMATH manual is over 200 pages and provides a complete description of each routine, including any algorithm and the mathematical formula the routine uses, shown in standard notation. For QuickBASIC 4 and BASCOM 6 only. **Just \$99.00!**



PROBAS™ TOOLKIT

The TOOLKIT is a collection of assembly and BASIC modules that use the PROBAS library to save you even more hours of grunt work. Why spend hundreds of hours re-inventing the wheel when you can just plug in TOOLKIT modules like:

- Menu Generators
- Fast B-tree indexing
- Mini-editor with word-wrap
- Patch .EXE files
- Protected storage areas
- Julian date routines

The TOOLKIT also includes clock, calendar, windowing, BCD math routines and much more, complete with BASIC source code and a comprehensive manual. The PROBAS TOOLKIT adds capabilities and helps conserve your most valuable asset of all—time! Requires PROBAS. **Just \$99.00!**

PROBAS™ TELECOMM TOOLKIT

The PROBAS TELECOMM TOOLKIT is a collection of high-level communications modules that you plug into your code to provide popular file transfer protocols, terminal emulations, login scripts and baud rates up to 115,200 baud. You get:

- Xmodem/Modem7/Xmodem-1k
- Ymodem (single and batch)
- CRC-16 and Checksum
- VT52, VT100, ANSI BBS etc.
- Auto Dialer & data base
- Documented BASIC source

Why use clumsy SHELLs to complex terminal programs when you can plug just the communications routines you need into your code? Implement just the features and commands you want. Requires PROBAS. **Just \$75.00!**

Our thirty day, money-back guarantee assures you the highest quality and our technical support staff is always ready to help. Try our BBS at (301) 953-7738 or give us a call at:

HAMMERLY
COMPUTER SERVICES, INC.

8008 SANDY SPRING ROAD • LAUREL, MD 20707
INTERNATIONAL CALLS: (301) 953-2191

(800) 343-7484

Add \$5.00 per item (\$8.00 Canada) for shipping per order. Europe: \$39.00 for 1st item plus \$5.00 for each additional item. Visa, M/C, C.O.D. (US Only) checks and approved POs accepted. Trademarks PROBAS, PROREF, PROSCREEN, PROMATH: Hammerly Computer Services, Inc. QuickBASIC, BASCOM: Microsoft Corp.

Sprint® software free
with T1200F purchase.

The Small Have Been Made Powerful.

Behold the new Toshiba T1200F

It's easily small enough to fit in the average briefcase, yet it's packed with a full megabyte of RAM, two 720KB 3½" diskette drives, and a variety of ports.

It comes in either reflective or backlit LCD models. A full-size keyboard. And for a limited time, it also comes with our exclusive version of Sprint®, Borland's powerful word processing software. Absolutely free. And because it weighs only 9.8 pounds, it's one of the lightest.

IBM-compatible dual diskette PCs on earth. It even has removable, rechargeable batteries, so you can work with it just about anywhere you want.

Those who've used the T1200F have hailed it as a small miracle.

Because rarely has so much power been so easily wielded.



And The Mighty Brought Down To Size.

Where is it written that hard disk has to mean hard to carry?

Witness the Toshiba T1200HB.

It only takes up about one square foot of desk and weighs less than eleven pounds, but it's packed with all the features of our T1200F and comes with a single diskette drive and 20 megabyte hard disk.*

Which means it's big enough to store just about all the applications you'll ever use. All the time.

And, like the T1200F, it has the convenience of Resume mode,

which remembers your place even after the unit is turned off.

For more information on all our computers and printers, call 1-800-457-7777 or visit one of our nearby Toshiba dealers.

They'll make a believer out of you.

Toshiba PCs are backed by the Exceptional Care program (no-cost enrollment required). See your dealer for details. IBM is a registered trademark of International Business Machines Corp. Sprint is a registered trademark of Borland Corp. *Excludes Sprint offer.



In Touch with Tomorrow
TOSHIBA

Toshiba America Inc., Information Systems Division

CLEO is your SNA, BSC and Coax Gateway

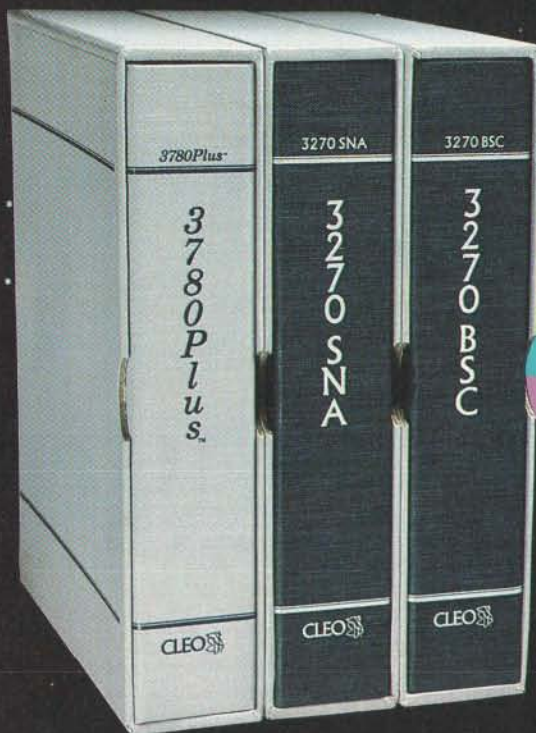

VMS
UNIX
XENIX
PC-DOS
Macintosh
NetBios LAN

Sharing Information

Whatever your industry, your computers need to share information with your mainframe. Or, they need to exchange data with other computers. In either case, you need a total communications solution. You need software, hardware interfaces and modems that all work together smoothly. You need CLEO!

CLEO software products allow your computer to communicate with mini-computers and mainframes, and to emulate their workstations. Since 1981, CLEO has provided communications between micros, minis, and mainframes for the automotive, insurance, medical and banking industries. Today over 78,000 CLEO users worldwide are running on all major computer brands. The greatest number of these users run CLEO software on IBM Personal Computers and NETBIOS LANs.

Complete Software/Hardware Package

Every CLEO package contains all the software and hardware accessories you'll need. Your selected CLEO SNA, BSC, or Coax software is packaged with 1) an internal modem card for dial-up applications, or 2) an interface card and cable for use with your existing modem, or 3) a Coax card for local connectivity. There's no waiting for non-CLEO add-ons. And, you get prompt, single-source service.



Package prices range from \$795.00 for most stand-alone packages, up to \$1,995.00 for the 32-user SNA gateway.

Call us today to discuss your application.

CLEO Software
1639 North Alpine Rd.
Rockford, IL 61107
Telex 703639
FAX 815/397-6535

Headquarters:

USA: 1-800/233-2536
Illinois: 1-800/422-2536
International: 815/397-8110

Sales and Distribution:

Benelux: 31 (0) 33-948888
Canada, East: 800/361-3185
Canada, West: 800/361-1210
Canada, Montreal: 514/737-3631
Colombia, S.A.: 12172266
Denmark: 02 94 81 19
England: (0993) 776543
France: 146861136
Italy: (0331) 634 562
Mexico City: 596-5539
Sweden: 468311780

CLEO 



SX Appeal



Compaq's 386s is the first of a new generation of microcomputers that implement Intel's low-cost 80386SX

Jeff Holtzman

One of the most exciting developments in microcomputers this year has been the introduction of the 80386SX microprocessor, which promises 80386 performance and software compatibility at AT prices. Compaq's 386s is the first personal computer built around this new chip. It's the harbinger of a new class of machines that's destined to become the entry point for 80386-level computing and eventually replace the AT as the mid-range microcomputer of choice.

The Compaq 386s has a small footprint, is lightweight, and packs a lot of power. But while the 386s's design takes full advantage of the SX chip's potential, the machine's relatively high price puts it in competition with more powerful 80386 systems.

Compaq offers the 386s in three configurations. The Model 1 (\$3799) has 1

megabyte of memory, a 5¼-inch floppy disk drive, a 101-key enhanced keyboard, and a 140-watt power supply. The Model 20 (\$4499) adds a 20-megabyte, 29-millisecond, 3-to-1 interleave enhanced-small-device-interface hard disk drive. The Model 40 (\$5199) offers a 40-megabyte, 29-ms, 1-to-1 interleave ESDI hard disk drive.

All models come with hard/floppy disk controllers, serial and parallel ports, a mouse port, and a 16-bit VGA-compatible video adapter on the motherboard. The 386s also includes Compaq's Expanded Memory Management software (CEMM), a disk cache, a RAM disk, and other utility programs. DOS (version 3.31) and OS/2 (version 1.0) are extra-cost options, however.

The motherboard has four 16-bit AT expansion slots and one proprietary 16-bit memory-expansion slot that holds up to 13 megabytes of RAM. Color and monochrome analog VGA monitors, tape backups, and a multitude of other options are also available. All models come with a 1-year warranty and carry FCC Class B certification.

I tested a Model 40 with 1.2-megabyte 5¼-inch and 1.44-megabyte 3½-inch floppy disk drives, a 40-megabyte hard disk drive, a 40-megabyte Irwin Magnetics tape backup with backup software that runs under both DOS and OS/2, 5 megabytes of RAM, an 80387SX math coprocessor, and a color VGA monitor. This brought the cost of my system to \$10,740.

Internal Affairs

Getting inside the 386s is easy; the cover is held on with three thumbscrews. It must have been a challenge for Compaq's engineers to fit everything into the narrow (15-inch) chassis. As the photo on page 198 shows, they did so by using some unusually shaped components and by arranging them efficiently.

The front of the chassis provides open-

continued

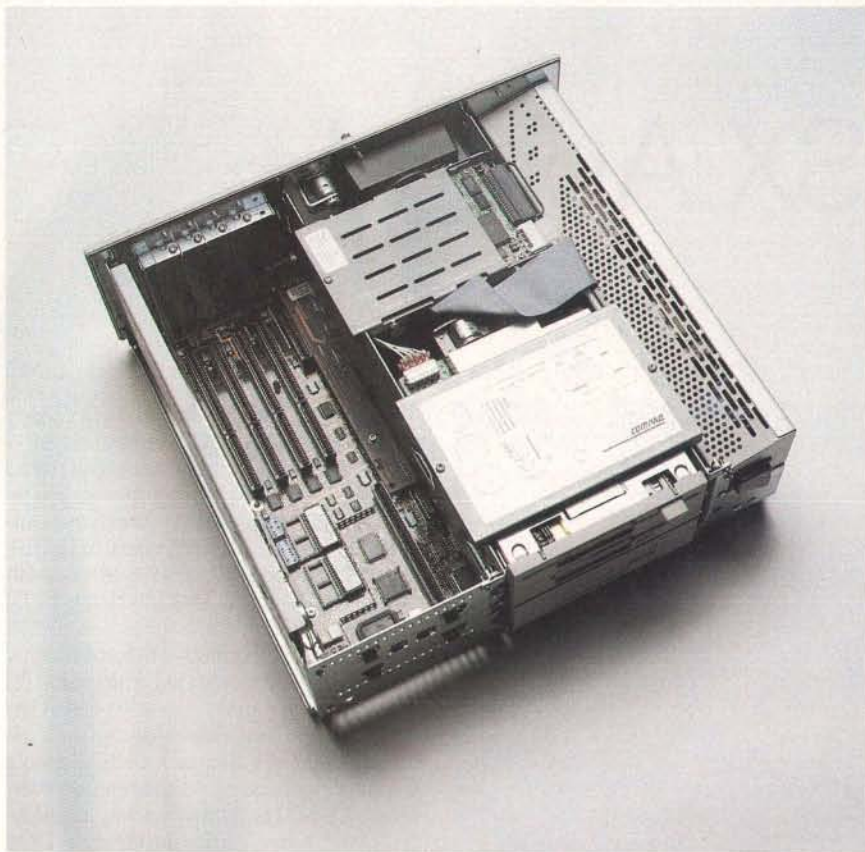

Internally, the 386s has a clean, compact design that fits neatly into a 15-inch-wide chassis.

ings for two one-third-height drives and one half-height storage device. Directly behind these are spaces for two 3½-inch internal drives. All drives mount in a separate subchassis; together, the power supply and the drive chassis occupy about 60 percent of the width of the case. Unfortunately, there is no reset switch. An LED lights up when power is on; another indicates hard disk drive activity.

Next to the drive chassis is a slot for Compaq's proprietary memory card, which also contains a VGA feature connector. There's no video circuitry on the memory card, however; it merely provides a path for signals from the motherboard and an additional sandwich card mounted above it.

As with Compaq's 80386-based machines, the memory slot operates at microprocessor speed (16 MHz), not expansion-bus speed (8 MHz). Both 1-megabyte and 4-megabyte expansion boards are available. Each is expandable by adding 1- or 4-megabyte modules, to a maximum of 13 megabytes of memory. You can add even more memory by using the regular expansion slots, but this will decrease system performance.

The motherboard, which measures 11 inches wide by 13 inches deep, is built almost entirely from surface-mount components and has an extremely clean look. More than half of it is obscured by the drive-bay subchassis, but most important things are easy to get at, including the CPU, ROM, and math coprocessor sockets and two system-configuration DIP switches. Unfortunately, a third DIP switch that specifies the amount of installed memory is partially obscured by the drive bays and memory card; they have to be removed to access the switch.

A chassis lock on the rear of the chassis doesn't provide an electrical keyboard interlock, as most AT compatibles do. However, an optional password feature performs the same function.

Run Time

The 386s's high-caliber documentation makes getting up and running easy, and the best part of Compaq's documentation is affixed to the chassis: two metallic labels that show the location of the major system components and the DIP-switch settings. If your machine gets separated

from its manuals, you'll still have no trouble setting it up.

The 386s also comes with an operations guide that contains Getting Started, Technical Overview, and User Program Reference booklets. The latter includes information on CEMM, CACHE, and VDISK. Compaq also sells two technical reference guides—one for the VGA subsystem and one for the 386s itself. Both contain in-depth descriptions of topics such as block diagrams, timing diagrams, and BIOS functions.

The setup process involves a bit more switch-flipping than do AT compatibles. Three DIP switches indicate the presence of the math coprocessor, boot speed, monitor type, optional power-on password, amount of memory, and so on. The switches also let you disable the on-board controllers (e.g., video, disk, and I/O ports) in case a fault develops on the motherboard or an expansion board requires it.

A conventional RAM-based setup program lets you specify items such as time and date, hard disk type, NumLock key boot state, the power-on password, and network server mode. In the network server mode, the machine boots only from the hard disk, and the keyboard remains inactive until you enter a password. The machine stores the password in CMOS RAM.

Compaq has taken an innovative approach to providing compatibility with software designed to run at slower speeds. You can use MODE.COM to set the machine's speed to any value between 1 (slow) and 50 (fast). The values that correspond to different PC speeds are listed in the technical reference guide.

Actual clock speed doesn't change; the expansion bus continues to operate at 8 MHz with one wait state. But the machine's refresh timing changes, increasing as the speed selected decreases to effectively lengthen the time each instruction takes to execute.

The 386s keyboard has an excellent feel and is the best I've tested. It provides the "clicky" tactile feedback of the IBM Enhanced keyboard, but it's not so noisy.

Compatibility Testing

I had no trouble installing and using a Hayes 2400-bit-per-second internal modem (Model 2400b) and a Microsoft Serial mouse. I also had no trouble installing and running DESQview 2.01 (with QEMM), 386MAX 2.36, WordStar Professional 4.0, a beta version of WordStar Professional 5.0, Turbo Pascal

continued



Compaq 386s

Compaq 386s **11.5***

APPLICATION-LEVEL PERFORMANCE

WORD PROCESSING

XyWrite III + 3.52	Med/Large
Load (large)	:13
Word count	:04/:27
Search/replace	:06/:26
End of document	:02/:15
Block moves	:10/:10
Spelling check	:11/1:22

Microsoft Word 4.0

Forward delete	:18
----------------	-----

Aldus PageMaker 1.0a

Load document	:10
Change/Bold	:32
Align right	:24
Cut 10 pages	:21
Place graphic	:04
Print to file	2:29

Index: **2.24**

SPREADSHEET

Lotus 1-2-3 2.01

Block copy	:04
Recalc	:02
Load Monte Carlo	:15
Recalc Monte Carlo	:06
Load rlarge3	:04
Recalc rlarge3	:01
Recalc Goal-seek	:04

Microsoft Excel 2.0

Fill right	:07
Undo fill	2:34
Recalc	:02
Load rlarge3	:26
Recalc rlarge3	:02

Index: **2.15**

DATABASE

dBASE III + 1.1

Copy	1:17
Index	:06
List	1:00
Append	2:11
Delete	:02
Pack	1:41
Count	:05
Sort	1:01

Index: **2.06**

SCIENTIFIC/ENGINEERING

AutoCAD 2.52

Load SoftWest	:57
Regen SoftWest	:45
Load StPauls	:12
Regen StPauls	:07
Hide/redraw	14:56

STAT 1.5

Graphics	:32
ANOVA	:13

MathCAD 2.0

IFS 800 pts.	:19
FFT/IFFT 1024 pts.	:20

Index: **3.01**

COMPILERS

Microsoft C 5.0

XLisp compile	5:01
---------------	------

Turbo Pascal 4.0

Pascal S compile	:05
------------------	-----

Index: **2.05**

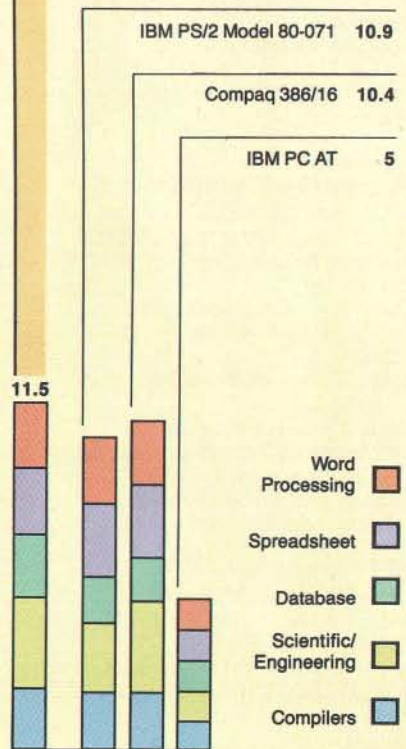

*Cumulative applications index. Graphs are based on indexes at left and show relative performance.

All times are in minutes:seconds. Indexes show relative performance; for all indexes, an 8-MHz IBM PC AT=1.

LOW-LEVEL PERFORMANCE¹

Compaq 386s

CPU

Matrix	6.69
String Move	
Byte-wide	52.48
Word-wide:	
Odd-bnd.	44.27
Even-bnd.	26.25
Doubleword-wide:	
Odd-bnd.	29.41
Even-bnd.	19.7
Sieve	36.10
Sort	30.79

Index: **1.86**

FLOATING POINT

Math	11.17
Error ²	0.00E+00
Sine(x)	3.23
Error	2.00E-09
e^x	3.49
Error	1.00E-09

Index: **5.03**

DISK I/O

Hard Seek³	
Outer track	3.32
Inner track	3.33
Half platter	9.92
Full platter	9.97
Average	6.63

DOS Seek

1-sector	14.37
32-sector	24.61

File I/O⁴

Seek	0.13
Read	0.64
Write	0.99
1-megabyte	
Write	4.70
Read	3.59

Index: **1.78**

VIDEO

Text	
Mode 0	4.63
Mode 1	4.63
Mode 2	4.61
Mode 3	4.61
Mode 7	N/A

Graphics

CGA:	
Mode 4	2.47
Mode 5	2.49
Mode 6	2.62
EGA:	
Mode 13	4.36
Mode 14	4.76
Mode 15	N/A
Mode 16	4.74
VGA:	
Mode 18	4.98
Mode 19	2.69

Index: **1.87**

CONVENTIONAL BENCHMARKS

LINPACK	242.66
Livermore Loops⁵	
(MFLOPS)	0.12
Dhrystone (MS C 5.0)	
(Dhry/sec)	3553.00

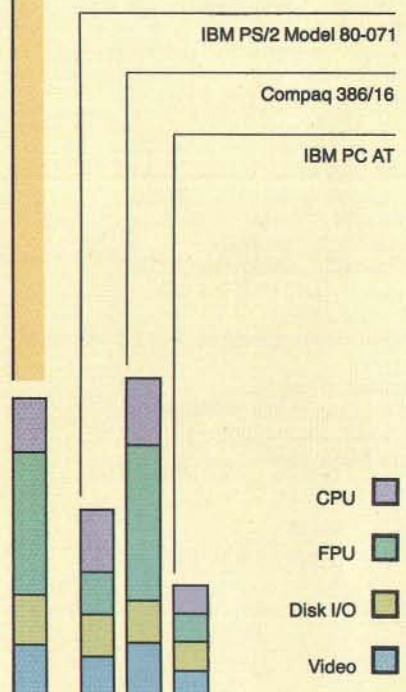

¹ All times are in seconds. Figures were generated using the 8088/8086 and 80386 versions (1.1) of Small-C.

² The errors for Floating Point indicate the difference between expected and actual values, correct to 10 digits or rounded to 2 digits.

³ Times reported by the Hard Seek and DOS Seek are for multiple seek operations (number of seeks performed currently set to 100).

⁴ Read and write times for File I/O are in seconds per 64K bytes.

⁵ For the Livermore Loops and Dhrystone tests only, higher numbers mean faster performance.

Compaq Deskpro 386s Model 40

Company

Compaq Computer Corp.
20555 FM 149
Houston, TX 77070
(713) 370-0670

Components

Processor: 16-MHz 80386SX; optional 80387SX math coprocessor
Memory: 1 megabyte of static-column RAM, expandable to 13 megabytes in proprietary slot
Mass storage: 1.2-megabyte 5¼-inch floppy disk drive; 40-megabyte ESDI hard disk drive
Display: On-board VGA adapter; optional monitors
Keyboard: 101-key enhanced
I/O interfaces: RS-232C (9-pin), parallel (25-pin), and mouse (PS/2-style DIN) ports; four 16-bit AT expansion slots; one 16-bit proprietary memory slot

Size

6 x 15 x 16 inches; 28 pounds

Software

Diagnostics test; system setup; ROM version; disk cache; RAM disk; CEMM software

Options

16-MHz 80387SX: \$799
1-megabyte memory-expansion board: \$799
4-megabyte memory-expansion board: \$2999
1-megabyte memory module: \$799
4-megabyte memory module: \$2999
1.2-megabyte 5¼-inch floppy disk drive: \$275
360K-byte 5¼-inch floppy disk drive: \$225
1.44-megabyte 3½-inch floppy disk drive: \$245
110-megabyte hard disk drive: \$3499
135-megabyte tape backup: \$1999
40-megabyte tape backup: \$799
Serial/parallel adapter: \$149
VGA color monitor: \$699
VGA monochrome monitor: \$255
MS-DOS 3.3 and BASIC: \$120
OS/2 1.0: \$325
Technical Reference Guide: \$149

Documentation

40-page Getting Started; 60-page Technical Overview; 80-page User Program Reference

Price

Model 40: \$5199
System as reviewed: \$10,740

Inquiry 883.

4.0, Microsoft BASIC 6.0, Lotus 1-2-3 version 2.01, VP-Planner 1.0, Professional CED 1.01a, Brooklyn Bridge 1.30, DeskLink 2.21, AutoCAD 9.0, AutoSketch enhanced version 1.01, Excel 2.0, PageMaker 3.0, and Smartcom III.

I did experience a problem with Compaq's OS/2 version 1.0B rev. B and the internal modem I'd installed. After installing OS/2, I received an error message stating that COM1 did not install because the device adapter could not be located. I removed the modem and reinstalled OS/2 without any problems. And when I also reinstalled the modem, I was unable to reproduce the problem.

Unlike some non-IBM versions of OS/2, you see the Program Selector screen when you boot the installation disk; this lets you choose either a DOS prompt, an OS/2 prompt, or a separate installation program. This program copies files from the floppy disk to the hard disk and lets you create a custom configuration for your system.

Also, Compaq's OS/2 puts about three dozen files in your root directory and divides the remainder among two sub-directories: \OS2 and \OS2.000. Unfortunately, like IBM's version of OS/2, Compaq's OS/2 doesn't include a dual-boot option. After installing the operating system on your hard disk, you must boot from a floppy disk to run DOS.

The only other distinguishing feature of Compaq's OS/2 is a configuration program that gives you a menu-based means of setting up the CONFIG.SYS file. The advantage is that you needn't switch into real mode to edit the file. (OS/2 does not come with a protected-mode editor—not even a protected-mode version of EDLIN.)

I also installed version 2.1 of Windows/386. Windows itself ran fine, as did applications including Excel 2.0 and PageMaker 3.0. However, I couldn't get Microsoft's extended memory driver, HIMEM.SYS, to run. According to Microsoft, the driver incorrectly identified the 386s as using the PS/2 method of switching address line A20; consequently, it detected no extended memory.

A version of HIMEM.SYS provided with an updated version of Windows/286 ran fine, providing an extra 58K bytes of memory. Microsoft is working to correct the fault with Windows/386, and a fix should be available by the time you read this review.

Architectural Details

Compaq built most of the 386s around AT standards, including the expansion

bus, direct-memory-access controllers, real-time clock, memory refresh, interrupt control, and keyboard controller. One interesting addition is a fail-safe timer that an advanced operating system (OS/2 or Unix, for example) can use to generate regular interrupts that prevent an errant program from hogging or locking up the system. Another timer is used in a one-shot mode to extend the refresh-request signal. This decreases system throughput, as discussed in conjunction with the mode speed command above. A BIOS function also allows programmed speed setting.

The memory system uses Compaq's page-mode architecture with no static RAM cache. Access to locations in a single 2K-byte page occurs with zero wait states; access to a location outside the current page occurs with two wait states. On the average, approximately 60 percent of memory accesses in the 386s occur outside the current page, resulting in an average of 0.8 wait states per memory access, according to Compaq.

The motherboard contains 1 megabyte of memory, of which 640K bytes is normally mapped to the first 640K bytes of CPU address space and the remaining 384K bytes is mapped to the top of the 16-megabyte address space. You can also configure the system to allocate only 256K or 512K bytes of memory beginning at 0000 hexadecimal; in each case, the remainder (768K and 512K bytes, respectively) is mapped to the top of the address space.

Whatever the base memory (256K, 512K, or 640K bytes), you can map down the upper 128K bytes of unused memory from F0E000h to 00E000h (i.e., 0000:E000), where it can run a write-protected copy of the ROM BIOS, the VGA BIOS, or both. Compaq also provides a special BIOS function for moving ROM contents. In addition, the location of the 128K-byte block of memory depends on the state of a special register that's accessible at I/O port address 878h or at memory address 80C0000h. Two bits in that register specify where the RAM is to reside and whether it's write-protected.

A Promise Fulfilled?

Does the 386s meet the promise of high performance at low cost? The answer, unfortunately, is not simple.

In terms of raw CPU performance, the 386s simply doesn't hold up to the performance attained by most of the 16-MHz 80386-based machines that BYTE has tested. Overall, the Deskpro 386/16

continued

The most influential laser printer in history.

we never stop asking

"What if..."

The Laser Printer that Created the Future

In 1984 when we introduced what we now fondly call the "LaserJet Printer Classic", people wondered if it would sell. It was "different". It was a breakthrough.

In the days before laser printers, the standard for external correspondence was printing that matched a typewriter font. Mixed text and graphics reports could only be done "cut and paste". Printing was noisy and slow.

You had three options. You could either get a fast printer. Or a quiet printer. Or a letter quality printer.

So when HP's LaserJet Printer appeared, it changed the world.

Setting a New Standard

HP's LaserJet Printer offered speed, quietness and quality in one machine.

Dealers took notice. So did software developers. The LaserJet Printer's ability to print multiple fonts, produce graphics, and shade areas, inspired software developers to incorporate these new features into their packages.

The press was intrigued. In February 1987, Hewlett-Packard's LaserJet Printer lined up with the IBM PC, Lotus 1-2-3, and Apple Macintosh on *Personal Computing's* list of "10 Most Significant Personal Computer Products of All Time."

While LaserJet Printer sales continued to grow, the product development team was busy looking for ways to enhance the printer to better meet customer needs.



Advancing the Standard of Excellence

In March 1987, Hewlett-Packard introduced the new LaserJet Series II Printer. What could customers expect from the new printer? Everything they liked about the "Classic" plus improved ease of use, font flexibility, paper management, and add-on memory. All in a lighter-weight unit that cost less than the original.

"We'd been listening closely to our customers all along", says Tom Old, customer satisfaction O/A manager. "Maybe that's why Hewlett-Packard leads the industry in meeting people's needs for laser printing."

▲ The HP LaserJet Series II Printer. The most exciting advance in laser printing since HP made it affordable in 1984.

▼ U.S. Laser Printer Industry Growth In Units Shipped. HP's LaserJet Printer family has played a significant role in the laser printer industry growth.

U.S. Laser Printer Industry Growth

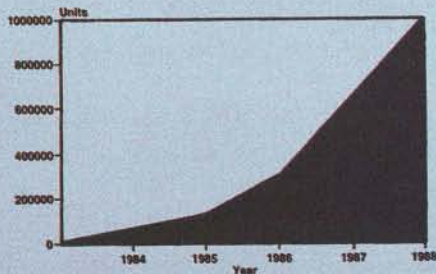

Source: Dataquest

This page was created using WordPerfect 5.0 software.

The laser printer that's influenced the entire printer industry can help you be more influential, too. The HP LaserJet Series II Printer is today's overwhelming choice for simple word processing, integrated text and graphics, and desktop publishing.

You can begin producing impressive documents right

from the start because the HP LaserJet Series II Printer works with all popular PCs and more than 600 PC software packages.

To see the HP LaserJet Series II Printer in action, call 1-800-752-0900, ext. 900E, for your nearest Hewlett-Packard dealer. You'll be more than influenced. You'll be convinced.

The HP LaserJet Series II Printer.

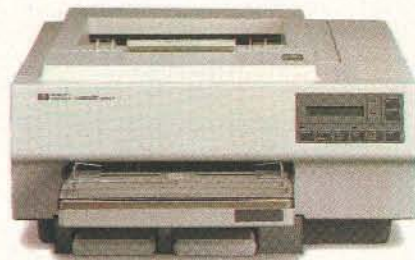

Computers For The Blind

Talking computers give blind and visually impaired people access to electronic information. The question is how and how much?

The answers can be found in "The Second Beginner's Guide to Personal Computers for the Blind and Visually Impaired" published by the National Braille Press. This comprehensive book contains a Buyer's Guide to talking microcomputers and large print display processors. More importantly it includes reviews, written by blind users, of software that works with speech.

This invaluable resource book offers details on training programs in computer applications for the blind, and other useful information on how to buy and use special equipment.

Send orders to:
National Braille Press Inc.
88 St. Stephen Street
Boston, MA 02115
(617) 266-6160

\$12.95 for braille or cassette, \$14.95 for print. (\$3 extra for UPS shipping)
NBP is a nonprofit braille printing and publishing house.

attains a CPU index of 2.20; the 386s, at 1.86, attains about 85 percent of the 386/16's raw computing horsepower.

The two machines performed nearly identically in the String Move tests, which indicates that raw memory throughput is not degraded by the 16-bit 386SX. But the 386s provided about 73 percent of the performance of Compaq's DeskPro 386/16 in the Sieve and Sort tests and about 79 percent in the Matrix test. The 20 percent to 25 percent difference in performance in the Sieve, Sort, and Matrix tests indicates that the 386SX simply can't keep up computationally with the 80386.

The Floating Point tests reveal that the 386s's lack of a 32-bit interface between the CPU and the FPU is a definite hindrance to math performance. The 386s exceeds only 80386 PCs with 80287 coprocessors—Compaq's early 386/16 models, for example. Machines with 80387s (such as the IBM PS/2 Model 80, Compaq's other 80386 systems, and the Dell System 310) easily beat the 386s.

Disk performance is another story. The 386s does well here and in video performance because the lack of a 32-bit data bus isn't a disadvantage. The 386s's ESDI hard disk drive achieved a BYTE index of 1.78, which easily surpassed the Deskpro 386/16, the 16-MHz and 20-MHz versions of the Model 80, and several other machines, including a preproduction version of IBM's PS/2 Model 70.

Video performance was also impressive. The unit's built-in 16-bit VGA adapter achieves an index of 1.87, which surpasses Compaq's 386/16 by a large margin and is just slightly slower than the 16-MHz Model 80. Most of the 386s's speed advantage is in text mode; in graphics mode, the Model 80 was about 15 percent faster, and the Deskpro 386/16 was about 2 percent faster.

Faster 80386 machines leave the 386s in the dust. The 25-MHz Deskpro, for example, achieves nearly twice the video performance. Because the width and speed of the two machines' expansion buses are identical, the raw speed with which the CPU processes video data is the determining factor here.

The real test, of course, is applications, and in this area the 386s is well above AT levels and solidly in the running with the 16-MHz 80386 machines. At 11.51, the 386s has an overall application index that's more than twice that of an AT, and it edges out Compaq's Deskpro 386/16 and the 16-MHz Model 80. The 20-MHz 80286-based Dell 220 with 2 megabytes of RAM and the 20-MHz Model 80 came in just above the 386s.

The 386s's application index is also well above that of high-performance ATs, such as the five machines reviewed in the July BYTE. The highest-performing member of that group, the Amdek System 286/A, achieved an overall application index of 9.8.

Reaching a Compromise

The 386s is a solid-performing machine that provides compatibility with 80386 software and proves that, with proper system design, the 80386SX is a good platform for demanding applications.

Not surprisingly, the 386s is not a machine for those demanding the utmost in performance. The fast disk and video subsystems help overcome the limitations of the 16-bit data bus, which restricts CPU and FPU performance, but the 386s doesn't support the Weitek math coprocessor, it has only four expansion slots, and the 140-watt power supply seems underpowered. The power supply in my review unit, which included only a memory card and a Hayes modem, ran uncomfortably hot to the touch.

It's hard to figure Compaq's pricing structure. For example, a 386s with 1 megabyte of memory, a 40-megabyte hard disk drive, and a color VGA monitor costs \$5898. By contrast, the Deskpro 386/16 costs \$7797—almost \$2000 more, although it performs roughly the same. At the other end of the scale, a 12-MHz 80286-based Compaq costs \$5497. For a \$400 difference, why buy the 80286?

The bottom line is that you can buy faster machines for considerably less money from competing manufacturers. A comparable Dell System 310, for example, costs \$4299, has a full 32-bit bus, and outperforms the 386s in all categories. Even Dell's new System 220, which sports a 20-MHz 80286, performs comparably. And while the Dell System 220 can't run 80386 software, at \$3199 it costs about half as much as the 386s.

The 386s is important: It's the first machine to use the 80386SX chip, and it proves that the 80386SX is a viable computing engine. It's the first entry in a new class of machines and a new category of computing power. Unfortunately, the 386s costs too much. The company that can build a quality 80386SX system and sell it at a competitive price will walk away with the market. ■

Jeff Holtzman owns Publishing Concepts, a firm that specializes in evaluation, verification, and documentation of high-technology products. He lives in Ann Arbor, Michigan. You can reach him on BIX c/o "editors."

An inside look at the best 386 value around.

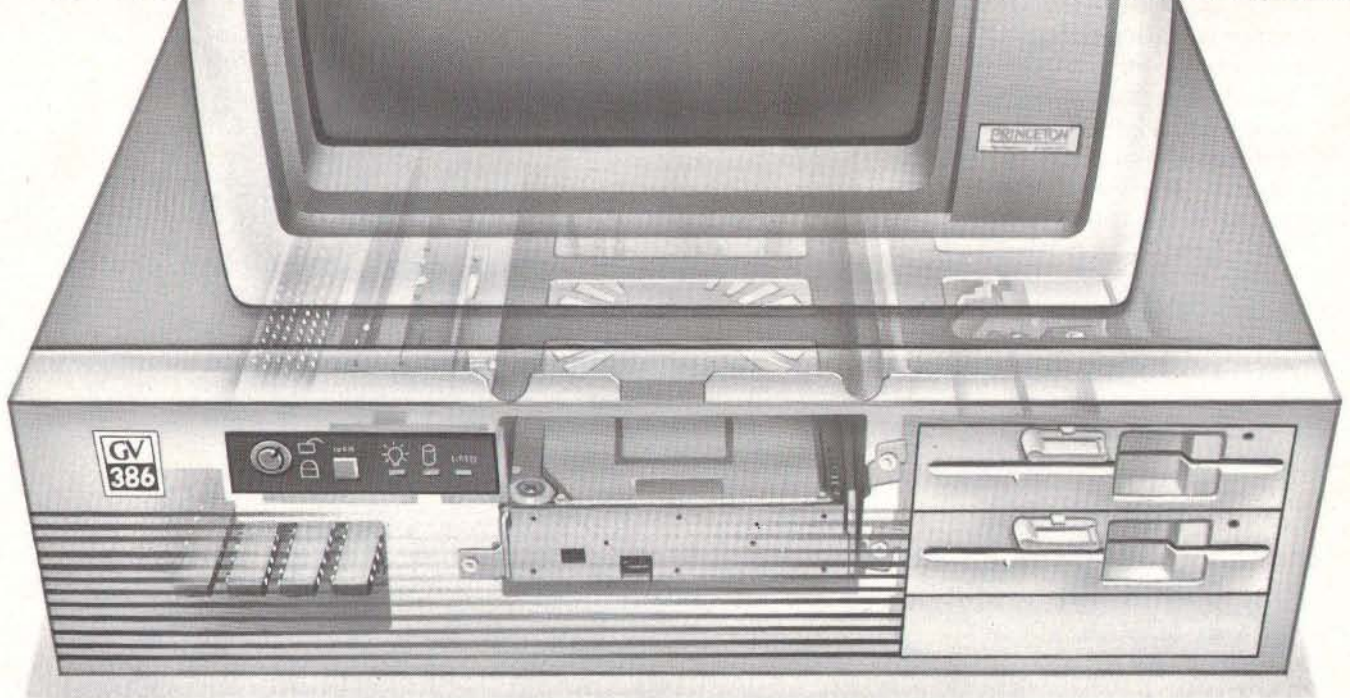

The more you look into 386 compatibles, the more you realize that well thought-out design innovations (that really work) are few and far between.

That's why our engineers set out to design the GV-386. They realized they could unlock more of the chip's potential, if only they could speed up data retrieval, without affecting system reliability.

INNER POWER

Here's how they did it: a high-speed RAM cache circuit—a full 64K of superfast memory—that puts your most frequently accessed data right at your fingertips. If you're ever involved in processing complex databases, long spreadsheets, or detailed engineering drawings, you'll see the value of this innovation in a second...literally.

Best of all, the cache circuit actually makes the GV-386 more reliable than other high-speed machines, by sparing integrated circuits from harsh overloading.

Our BBS is on-line 24 hours.
Call The Soft Stop at 918-252-9137.

Prices subject to change.

Circle 248 on Reader Service Card

QUALITY THROUGHOUT

Of course, our most important criterion when designing our super compatible wasn't speed—it was quality. Take a look inside the GV-386 and you'll see it everywhere: from the highest quality components available to the intelligent use of special CMOS RAM to store system set-up information. On the outside, the fit and finish of the GV-386 would make Big Blue green. Even the user's manual has impressed users and reviewers alike.

We'd like to tell you more about what went into the GV-386. Give us a call and we'll give you the whole story. We'll also tell you about our exclusive 30-Day Compatibility Guarantee, our full One-Year Warranty and our toll-free support service.

The GV-386 from PC Designs. With design innovations this advanced, at this price, it's an open and shut case.

PC Designs

Call us now at 1-800-32-BIT PC
(800-322-4872)

2500 N. Hemlock Circle, Broken Arrow, OK 74012
• 918-251-5550 (Fax: 918-251-7057)
19 Rector Street, Suite 2705, New York, NY 10006
• 212-514-7280 (Fax: 212-797-3973)

GV-386 Specifications

- Available with 16MHz or 20MHz CPU
- Zero Wait States
- 64K Cache (keyboard enabled)
- 1MB RAM on-board, expandable to 4MB
- Socketed for 80287 or 80387
- I/O Bus runs at 8MHz for hardware compatibility
- Six 16-bit slots; Two 8-bit slots
- Price: 20MHz systems start at \$2,750; 16MHz systems as low as \$2,375

FLEXSCAN™ 9070S, PC Hi-Res That Looks Like a Million.

The FLEXSCAN 9070 Multiple Scan monitor is of course compatible with other multi-scans, but includes improvements that will give you the professional edge which is the mark of a good investment. You can extend your multi-scan range from 20kHz to 50kHz in practical terms. This means that, at the 48-50 kHz range, you can make use of PC CAD/CAE capabilities at a resolution of up to 1024 dots × 768 lines. The FLEXSCAN 9070 takes advantage of non-interlace high resolution signal as high as 1024 × 768 to provide you with a flicker free display at much brightness. You can also use the 9070 with IBM PS/2 or VGA compatible boards at a high resolution mode like 800×600 and 1024×768 (non-interlace). The FLEXSCAN 9070 provides a 16-inch screen, large enough for CAD/CAE and 3-D projections, yet small enough to fit comfortably into your home work space.



1024 dots × 768 lines Graphics (Non-interlace)
AutoCAD

Also, for your convenience, all controls and switches, including the alternate video input, are located within easy reach on the front panel. The FLEXSCAN 9070 is compatible with a wide range of IBM, Apple, and other products, allow you to use all of today's popular programs---at a resolution that looks like a million.

FLEXSCAN™ MODEL 9070S

- IBM VGA(PS/2), 8514 /A, PGC, EGA compatible and CAD/CAE use.
- Apple Mac II and SuperMac Spectrum compatible
- Max. 1280 dots × 800 lines high resolution
- 1024 dots × 768 lines display on Non-Interlace signal delivers flicker-free high-res graphics
- 20kHz to 50kHz horizontal scan automatic adjustment. 50Hz to 80Hz vertical scan automatic adjustment
- 16 inch, 0.31mm dot pitch and newly developed XF(Extended Field) Gun to obtain both brightness and sharp focus.
- Front mounted controls including the input signal select switch between 2 video input.
- Selecting white or Amber displays colored application in shades of gray or amber
- Tilt-Swivel stand standard

Come see us at COMDEX
Booth #H8324

NANA O®

NANA O USA CORPORATION

23510 TELLO AVE., SUITE 5 TORRANCE, CA 90505
PHONE (213) 325-5202 FAX (213) 530-1679

Specifications are subject to change without notice.

APPLE, Macintosh II are registered trademarks of Apple Computers Inc. ARTIST, ARTIST 1 Plus, ARTIST 10, ARTIST 10/16 are trademarks of Control Systems Inc. IBM, IBM PC, XT, AT and PS/2 are registered trademarks of International Business Machines Corporation. SuperMac is a trademark of SuperMac Technology. SuperEGA HiRes, SuperVGA and SuperVGA HiRes are trademarks of Genoa System Corporation. Orchid Designer VGA, Orchid Designer VGA-2, TurboEGA and TurboVGA are trademarks of Orchid Technology. Paradise VGA Professional Card, Paradise VGA Plus Card and Autoswitch EGA are trademarks of Paradise Systems, Inc. Paradise Systems is a registered trademark of Paradise Systems, Inc. VEGA Deluxe and VEGA VGA are trademarks of Video-seven Inc. Metheus is a registered trademark of Metheus Corporation. Imagraph is a trademark of Imagraph Corporation. AutoCAD is a registered trademark of Autodesk Inc. GEM is a registered trademark of Digital Research Inc. Lotus and 1-2-3 are registered trademarks of Lotus Development Corporation. SigmaVGA and SigmaEGA are trademarks of Sigma designs, Inc. FLEXSCAN is a trademark of NANA O CORPORATION. NANA O is a registered trademark of NANA O CORPORATION.



ALR Improves on a Winner



The FlexCache 25386 breaks the speed record with its 25-MHz 80386 and enhanced caching system

Mark L. Van Name

Advanced Logic Research has once again claimed the PC performance lead with its FlexCache 25386. The new machine is based on the same proprietary FlexCache architecture that ALR used in its top-performing FlexCache 20386 (June BYTE). This architecture combines a high-speed cache of static RAM (SRAM) with dual memory and I/O buses to let the 80386 CPU run without wait states 95 percent of the time.

The 25386 differs from the earlier 20386, however, in the size, speed, and management of its cache. The 20386 uses the Intel 82385 cache controller chip to manage a 32K-byte cache of 35-nanosecond SRAM. The 25386 has a larger 64K-byte cache of faster 25-ns SRAM. It also replaces the 82385 with ALR's proprietary Extended Emulation 82385 cache system, which provides several perfor-

mance improvements. The 25386 also uses faster 60-ns dynamic RAM in place of the 80-ns DRAM in the 20386.

All this adds up to record-breaking performance for the FlexCache 25386. But the 25386's high performance does not come cheap. It is available in two versions, the \$9499 Model 150 and the \$12,499 Model 300, which differ only in the size (150 and 300 megabytes, respectively) and speed of their hard disk drives. Both models include the 25-MHz 80386, the 64K-byte cache, 2 megabytes of memory, a socket for either a 25-MHz or a 20-MHz Intel 80387 math coprocessor, a 1.2-megabyte 5¼-inch floppy disk drive, ALR's 16-bit VGA card, an enhanced-small-device-interface (ESDI) controller and hard disk drive, one parallel port, one RS-232C serial port, and a keyboard that follows the layout of the IBM Enhanced AT layout. The only software that I received was ALR's FlexCache 386 Setup Utilities disk.

Of course, to use the 25386 you also need a monitor and some operating-system software. My evaluation unit came with MS-DOS/GWBASIC 3.3, as well as a 25-MHz 80387 and a 1.44-megabyte 3½-inch floppy disk drive. ALR does not currently sell a monitor, so I used an IBM 8514 analog VGA monitor with the system.

Not counting the price of the monitor, the evaluation unit cost \$14,798. Toss in another \$600—the street price for a reasonable VGA monitor—and you end up with a healthy \$15,398.

As high as that is, it is still not as expensive as a comparable Compaq 386/25. The Compaq 386/25 Model 300 costs \$13,299, which is \$800 more than the 25386 Model 300; the 386/25 also has only 1 megabyte of slower DRAM and a smaller and slower cache.

ALR also offers two 25-MHz systems with almost the same performance as the FlexCache 25386 and at much cheaper prices: its desktop 25386 DT Model R66

continued

ALR FlexCache 25386

Company

Advanced Logic Research, Inc.
9401 Jeronimo
Irvine, CA 92718
(800) 444-4257

Components

Processor: 25-MHz 32-bit Intel 80386; socket for 25-MHz or 20-MHz Intel 80387 coprocessor
Memory: 2 megabytes of 32-bit, 60-ns DRAM, expandable on the FlexMem card to 14 megabytes; 64K bytes of 25-ns SRAM; 128K bytes of BIOS ROM
Mass storage: 1.2-megabyte 5¼-inch floppy disk drive; 1.44-megabyte 3½-inch floppy disk drive; 150-megabyte hard disk drive (Model 150) or 300-megabyte hard disk drive (Model 300)
Display: ALR 16-bit VGA board; no monitors currently available from ALR
Keyboard: 101 keys in IBM Enhanced keyboard layout
I/O interfaces: One RS-232C serial port with DB-9 connector; one DB-25 parallel port; one VGA monitor port with DB-15 connector; one 32-bit expansion slot for the FlexMem memory-expansion card; one 8-bit expansion slot; six 8-/16-bit expansion slots

Size

7½ x 17 x 26 inches; 80-100 pounds

Software

FlexCache 386 Setup Utilities disk, version 4.2, with diagnostics tests, system setup, SETSPEED program, and other utilities; VGA Card Utilities disk

Options

1-megabyte memory module: \$1049
4-megabyte memory module: \$2995
360K-byte 5¼-inch floppy disk drive: \$205
1.2-megabyte 5¼-inch floppy disk drive: \$225
1.44-megabyte 3½-inch floppy disk drive: \$225
20-MHz 80387 coprocessor: \$1199
25-MHz 80387 coprocessor: \$1899
150-megabyte hard disk drive: \$2499
300-megabyte hard disk drive: \$3999
ALR EGA card: \$349
ALR 16-bit VGA card: \$399
MS-DOS/GWBASIC 3.3: \$175
SCO Xenix 386 V.3: \$695

Documentation

FlexCache 25386 User's Manual; VGA Card User's Guide; VGA Card Software Manual

Price

Model 150: \$9499
Model 300: \$12,499
System as reviewed: \$14,798

Inquiry 885.

and Model 100. These systems have only 1 megabyte of DRAM and smaller, slower hard disk drives, but at \$6490 and \$6990, respectively, they're in a price range that more of us can handle.

Improving the FlexCache Architecture

Nearly all of today's fastest 80386-based systems use the Intel 82385 cache controller. The 25386 breaks from this group by using ALR's new proprietary cache controller, the Extended Emulation 82385 cache system.

ALR based this new cache system on the Intel 82385 cache controller, but it has added several improvements and has implemented the whole thing with a group of chips on the 25386's motherboard. Many of these improvements are very small, but a few are worth mentioning here.

One improvement affects how the 25386's cache system maintains cache "coherency"—the consistency of cache data with the corresponding DRAM locations. When a direct-memory-access (DMA) write changes a memory location whose contents are in the cache, the Intel 82385 cache controller marks that cache data as invalid, so that subsequent accesses to it will force the system to read the data from the DRAM. The 25386's cache system, on the other hand, updates the cache data on DMA writes, thereby maintaining cache coherency.

Another big improvement is that the 25386's cache system runs parallel with main memory, so that it does not add a wait state when there is a cache miss. The 82385 imposes an additional wait-state penalty for each cache miss.

The 25386 hedges its performance bet further by using expensive but fast 60-ns main memory, in contrast to Compaq's 100-ns memory.

All this DRAM sits on a proprietary 32-bit bus. The 25386 also contains a standard 8-MHz AT-style bus that supports standard AT expansion cards.

Tops in Performance

The result of these architectural improvements? The 25386 flat-out beat every other 80386-based system that BYTE has benchmarked, including a preproduction Compaq Deskpro 386/25. Of course, the 25386 beat Compaq's 386/20 by a 40 percent margin in the CPU low-level test, as well as by smaller margins in the Floating Point and Disk I/O low-level tests. It also had a slight edge overall in the application performance tests.

The only deficiency appears in the

Video Text and Database test results. The original benchmark tests were run with the IBM 8514 monitor. In those tests, the 25386 was over 2½ times slower than the Compaq 386/20. When BYTE reran the tests with the 25386 using the Compaq Video Graphics Color Monitor Model 420, the 25386 was only 20 percent slower than the Compaq 386/20. I attribute this change in performance to the interaction between the ALR VGA card and the IBM 8514 monitor. The ALR VGA card also appears to be optimized for graphics display rather than for text. An ALR spokesperson said that the company would investigate this discrepancy.

A Few Glitches

Speed is no good, of course, if you can't run your favorite programs and install your favorite expansion cards.

The 25386 is very good about hardware compatibility. While the 20386 runs its AT-style expansion bus at 10 MHz, a speed that could cause problems for older expansion boards, the 25386 uses a standard 8-MHz AT-style bus. I installed an Everex Evercom II 2400-bit-per-second internal modem and an Intel Above Board/AT expanded-memory board, as well as a Microsoft Serial Mouse, and all ran without a hitch.

The news is not quite so good on the software side. The 25386 ran almost all the software I tried, including Borland's Quattro 1.0, Reflex 1.14, SideKick Plus 1.00A, SuperKey 1.16A, Turbo C 1.0, and Turbo Pascal 4.0; Digitalk's Smalltalk/V 1.2; Kermit 2.30; MicroPro's WordStar 3.3 and 4.0; Microsoft's PC Paintbrush 2.0, Windows/386 version 2.0, and Word 4.0; Norton Utilities 3.00; Quarterdeck Office Systems' DESQview 2.0, with its Quarterdeck Expanded Memory Manager 386 version 1.10; and Symantec's Q&A 1.1.

During my software tests, however, I ran into three problems. The first involved a copy-protected Lotus 1-2-3 version 2.0. I could not get 1-2-3 to recognize the key disk, even when I slowed the system to its 8-MHz-equivalent compatibility speed. It is no surprise that 1-2-3 did not recognize the key disk when the 25386 was at full speed, for the 80386's high speed messes up 1-2-3's copy-protection scheme. Most 80386-based systems handle this problem either by slowing the system automatically when a program reads data from a floppy disk or by letting you slow the system manually from the keyboard.

An ALR spokesperson said that the

continued



ALR FlexCache 25386

APPLICATION-LEVEL PERFORMANCE

ALR FlexCache 25386 **21.2***

WORD PROCESSING		DATABASE	
XyWrite III+ 3.52		dBASE III+ 1.1	
Load (large)	:11	Copy	:33
Word count	:02/:12	Index	:05
Search/replace	:03/:13	List	1:08
End of document	:01/:08	Append	1:19
Block moves	:08/:08	Delete	:02
Spelling check	:05/:37	Pack	1:11
Microsoft Word 4.0		Count	:03
Forward delete	:10	Sort	:46
Aldus PageMaker 1.0a		Index:	2.83
Load document	:02	ENGINEERING/SCIENTIFIC	
Change/bold	:15	AutoCAD 2.52	
Align right	:12	Load SoftWest	:27
Cut 10 pages	:11	Regen SoftWest	:21
Place graphic	:02	Load StPauls	:06
Print to file	1:11	Regen StPauls	:04
Index:	4.41	Hide/redraw	7:02
SPREADSHEET		STATATA 1.5	
Lotus 1-2-3 2.01		Graphics	:19
Block copy	:02	ANOVA	:09
Recalc	:01	MathCAD 2.0	
Load Monte Carlo	:08	IFS 800 pts.	:09
Recalc Monte Carlo	:03	FFT/IFFT 1024 pts.	:09
Load rlarge3	:02	Index:	5.80
Recalc rlarge3	:01	COMPILERS	
Recalc Goal-seek	:02	Microsoft C 5.0	
Microsoft Excel 2.0		XLisp compile	2:29
Fill right	:03	Turbo Pascal 4.0	
Undo fill	1:08	Pascal S compile	:03
Recalc	:01	Index:	4.08
Load rlarge3	:13	CONVENTIONAL BENCHMARKS	
Recalc rlarge3	:01	LINPACK	135.01
Index:	4.13	Livermore Loops ⁵	0.19
		Dhrystone (MS C 5.0)	8417.00
		(Dhry/sec)	

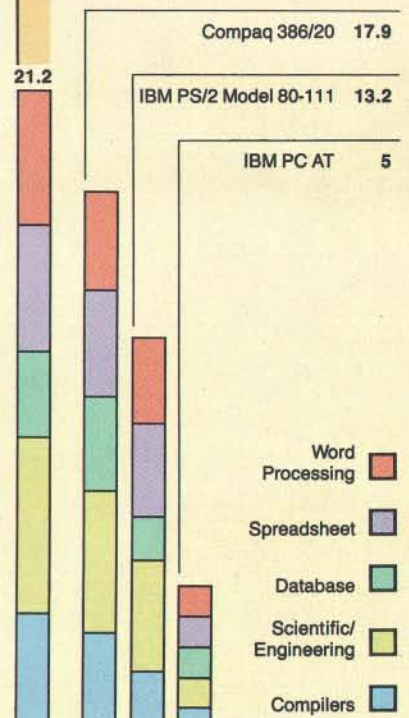

*Cumulative applications index. Graphs are based on indexes at left and show relative performance.

All times are in minutes:seconds. Indexes show relative performance; for all indexes, an 8-MHz IBM PC AT=1.

LOW-LEVEL PERFORMANCE¹

ALR FlexCache 25386

CPU		DISK I/O		VIDEO	
Matrix		Hard Seek³		Text	
String Move	2.60	Outer track	1.64	Mode 0	4.67
Byte-wide	16.20	Inner track	3.33	Mode 1	4.63
Word-wide:		Half platter	6.67	Mode 2	4.56
Odd-bnd.	21.97	Full platter	8.35	Mode 3	4.56
Even-bnd.	8.13	Average	5.00	Mode 7	N/A
Doubleword-wide:		DOS Seek		Graphics	
Odd-bnd.	15.93	1-sector	6.93	CGA:	
Even-bnd.	4.03	32-sector	15.35	Mode 4	1.12
Sieve	14.02	File I/O⁴		Mode 5	1.12
Sort	10.50	Seek	0.06	Mode 6	1.19
Index:	5.07	Read	0.49	Mode 13	2.58
		Write	0.78	Mode 14	2.75
		1-megabyte		Mode 15	N/A
		Write	2.91	Mode 16	2.75
		Read	2.92	VGA:	
FLOATING POINT		Index:	2.74	Mode 18	2.86
Math	4.90			Mode 19	1.17
Error ²				Hercules	N/A
Sine(x)	1.54			Index:	2.57
Error					
e^x	1.81				
Error					
Index:	10.55				

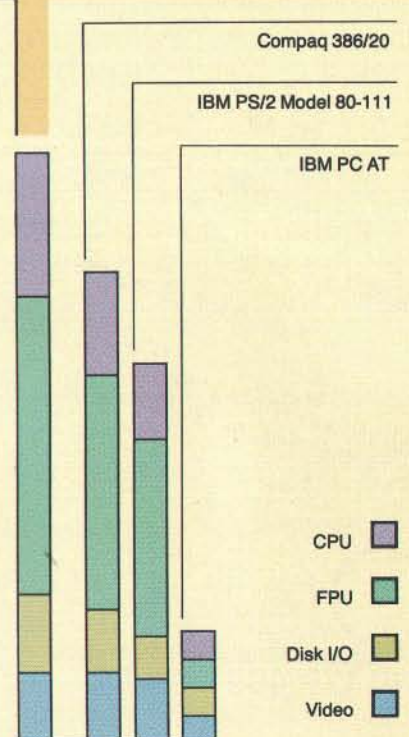

N/A = Not supported by graphics adapter.

¹ All times are in seconds. Figures were generated using the 8088/8086 and 80386 versions (1.1) of Small-C.

² The errors for Floating Point indicate the difference between expected and actual values, correct to 10 digits or rounded to 2 digits.

³ Times reported by the Hard Seek and DOS Seek are for multiple seek operations (number of seeks performed currently set to 100).

⁴ Read and write times for File I/O are in seconds per 64K bytes.

⁵ For the Livermore Loops and Dhrystone tests only, higher numbers mean faster performance.

IEEE-Z

Our Personal488™ IEEE (GPIB) interfaces for PC/AT/386 & PS/2s are packed with these easy-to-use features:

- DOS device driver loads at power-on
- Hewlett-Packard style commands
- Automatic error indication
- BASIC ON SRQ GOSUB capability
- DMA transfers over 300K bytes/s
- Up to four IEEE boards/computer
- NEC-7210 compatible software
- Serial/Parallel/IEEE port redirection
- DMA and interrupt channel sharing
- Compatible with popular languages (no extras to buy), including BASICA, GWBASIC, Quick BASIC, Compiled BASIC, Turbo BASIC, True BASIC, TBASIC, Turbo Pascal, Microsoft Pascal, Turbo C, Microsoft C, Aztec C, Lattice C, Microsoft Fortran, Lotus 1-2-3/Symphony/Measure, ASYST, DADiSP, Test Windows, AutoCAD, and many more.

- 30 day money-back guarantee
- 2 year warranty
- Call or send for your FREE Technical Guide

LOtech

(216) 439-4091 Telex 6502820864
Fax (216) 439-4093
25971 Cannon Road • Cleveland, Ohio 44146
London (0734) 86-12-87 • Paris (1) 34810178 • Zurich (01) 821 9444
Milan 02-4120360 • Linköping 013 11 01 40 • Amsterdam 01830-35333
Vienna (0222)253626 • Munich and other European, North African, and Middle East countries not listed (089) 710020.

Circle 166 on Reader Service Card

problem was probably due to the way the system implemented the compatibility speed, and that ALR uses a different technique in the current production machines to slow the 25386 automatically any time it uses a floppy disk drive. The spokesperson said that the same version of 1-2-3 ran without flaws on those systems.

My other two problems were subtle ones involving the interaction of the MS-DOS FDISK program and my system's 300-megabyte hard disk drive. I hung the system every time I tried to create a 32-megabyte logical drive in the last 48 megabytes of the disk. Also, every time I created logical drives and left FDISK, the system would reboot to the C>: prompt and then hang while it continuously tried to read drive A. At that point I had to shut the system down and then turn it back on.

I was able to work around the first problem by dividing the remaining disk space into two partitions that were both smaller than 32 megabytes, but I had no solution to the second difficulty. An ALR spokesperson said that the company would investigate these problems.

Disk Space to Burn

A 300-megabyte hard disk drive like the one on my evaluation unit really makes you aware of the MS-DOS 32-megabyte logical drive limit: I had logical drives C through L.

My evaluation unit's hard disk drive was a Maxtor Model XT-4380E, which has 380 megabytes of unformatted space that reduces to 300.7 megabytes when you format it. It had an average access time of 16 milliseconds. The hard disk controller was a Western Digital ESDI board that runs with 1-to-1 interleaving and includes a 16K-byte buffer for full-track buffering.

The 25386 contains another drive bay that can handle one full-height or two half-height 5¼-inch devices. For example, you could put a second 300-megabyte drive in that bay, bringing the system up to 600 megabytes of hard disk space.

Even with the Toshiba 1.2-megabyte 5¼-inch floppy disk drive and the TEAC 1.44-megabyte 3½-inch floppy disk drive in my unit, there was room for one more half-height 5¼-inch storage device. ALR offers a 150-megabyte ¼-inch streaming tape drive that would fit nicely into that slot.

The Box Itself

As you might imagine, any machine that can handle all these storage devices has

to be big, and the 25386 certainly is. It is over an inch thicker, 5 inches longer, and an inch deeper than a standard IBM PC AT. It is also heavy; my unit weighed nearly 80 pounds, and it can run to almost 100 pounds when it's fully loaded. Fortunately, the 25386 is not intended to sit on your desk. It stands upright on the floor.

While its size and weight may at first be daunting, the 25386 is easy to open. You just loosen two thumbscrews on the rear of the system to remove a side panel.

Once you're inside, you can see the 25386's eight full-length expansion slots: one 32-bit, one 8-bit, and six 8-/16-bit slots. The 32-bit slot looks like two AT-style slots, one in front of the other, and you can use the two connectors only for ALR's FlexMem 32-bit expansion card.

In my evaluation unit, the FlexMem card filled the 32-bit slot, and the VGA, ESDI controller, and multifunction floppy disk drive controller and serial/parallel port card were in three of the 8-/16-bit slots. There were still four empty slots, so the system has plenty of room for growth.

The 16-bit VGA card is a Western Digital ¼-length card based on Paradise's PVGA chips. It is hardware-compatible with IBM's VGA standard. It also offers an extended graphics mode with 800- by 600-pixel graphics resolution that will work on a multifrequency monitor—but not on a standard analog VGA monitor. There was a slight problem with this card: During the video benchmarks, the screen display had a light pattern of speckles. Replacing the video card and BIOS ROMs did not correct the problem. An ALR spokesperson could not explain why the problem occurred but said the company would investigate.

The motherboard is ALR's own. It measures about 13¼ by 12 inches. It is not the same motherboard that ALR used in the 20386; the company has redesigned and improved it since that earlier system. The motherboard in the review unit contained 154 chips, including the 80386, an 80387, and 1 megabyte of DRAM in 36 256K-bit chips. Many of the chips are fairly standard parts, such as the Chips & Technologies DMA controller and Phoenix's keyboard controller and ROM BIOS (version 1.10 03). A large group of new chips in the upper front of the board provides the Extended Emulation cache system.

The system's standard 2 megabytes of memory is split between the 1 megabyte that is standard on the motherboard and

continued

See DOS run.



Look at DOS. It looks back at you.
It makes you do all the work.
You need the Norton Commander.



See this user-defined menu.
It runs your favorite programs and
routines at a keystroke.



View two directories—from one or
two disks—at once.
And move your files around quickly.



Pull down a menu for quick,
easy access to the full power and
features of the program.

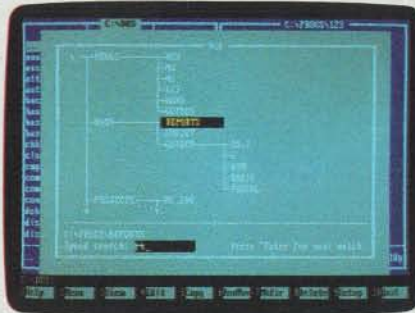

Want a tree view? Just pop
up a window. You can scroll, mouse
or Speed Search for directories.



To see your files, pick a
directory on the left and see the
contents on the right.



Remember your last 15 commands?
Our Command History does.
Take your pick and run them again.



View your dBASE® II or III data
without having to run dBASE.
It's as close as a keystroke.

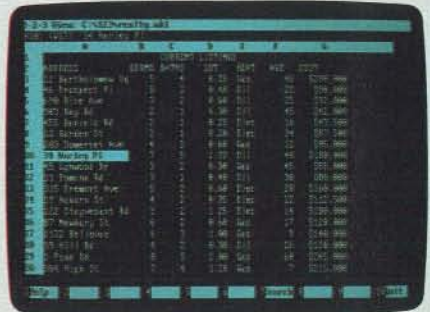

Another keystroke shows Lotus®
1-2-3® or Symphony® files—with-
out running 1-2-3 or Symphony.

See DOS run like you've never seen it before. Like you won't see it run with any other DOS enhancement shell. See version 2.0 of the Norton Commander™—a dramatically advanced version of the program *Infoworld* called "tops in its class... a new level of convenience for MS/DOS users." The new Norton Commander combines the functions of a hard disk manager with all the features you need to support and enhance the DOS command line. Yet it's flexible enough to get out of your way when you don't need to see it. Novice or expert, you'll want to see your dealer right away. And see how fast DOS can run.

Peter Norton
COMPUTING

Circle 254 on Reader Service Card (DEALERS: 255)



the basic 1-megabyte FlexMem card. You can expand the 25386's memory to a maximum of 14 megabytes by adding up to three 1-megabyte or 4-megabyte daughtercard memory modules to the FlexMem card.

You can install either a 20-MHz or a 25-MHz 80387 by setting a DIP switch. There is no socket for a Weitek math coprocessor, but ALR left solder positions around the 80387 socket to support a Weitek socket in the future.

Also, while all the DRAM in my evaluation unit was in 256K-bit chips, ALR has left enough room and solder positions around all the memory chips to support 1-megabit DRAM chips in the future.

The Rest of the System

The 25386's keyboard is an ME 101 Maxi-Switch model from EECO. It uses the basic IBM Enhanced keyboard layout, but it differs from that standard by having the backslash key next to a re-

duced Backspace key, in the older AT style. It has the nice feature that you can swap the functions of the Control and Caps Lock keys by changing a DIP switch on its back. ALR even includes an alternate set of correctly sized Control and Caps Lock keys.

The only standard software that I received with the 25386 was ALR's Setup Utilities disk. It contains such things as a system setup program, a speed change program, a low-level disk formatter, and system diagnostics, as well as several other utilities.

The standard documentation is the FlexCache 25386's User's Manual. This manual is full of useful technical detail, but once you leave the first two chapters you need to know a fair amount of computer terminology to keep reading. It's great for the experienced user, but not too useful for the novice. Of course, not a lot of novices are likely to start out on a \$15,000 system.

When You Need Help

The 25386, like other ALR systems, comes with a 1-year parts and labor warranty. You can also buy from 1 to 3 years of extended warranty service, but it's not cheap; one extra year costs \$725 for the Model 150 and \$935 for the Model 300. An ALR spokesperson said that ALR is now finalizing its plans to offer on-site service nationwide through another company.

You also get unlimited telephone support from ALR. The support people with whom I spoke were still learning the details of the recently announced 25386, but they were all knowledgeable and eager to help. My only complaints about ALR's support are that you have to make a toll call and, in my experience, sit on hold for about 5 minutes before you get to talk to a support technician.

Top of the Heap

ALR still needs to wring out a few compatibility problems, which it seems to be doing. Otherwise, the 25386 is a solid system that offers plenty of expansion space and more disk storage than most of us will need for some time.

It's the fastest 80386-based system available today, so if you want the top performer, shop no further. As a bonus, it's not even the most expensive 25-MHz system—nevertheless, it is only for those willing to pay for top performance. ■

Mark L. Van Name is a freelance writer and computer consultant living in Durham, North Carolina. He can be reached on BIX c/o "editors."

SUNDAY 10-5

PROMPT DELIVERY

APPLE Mac SE 2-800K Mac SE w/HD Mac II 1-800K Mac II w/HD 20 MB HD Ext. 40 MB HD Ext. ImageWriter II ImageWriter II ImageWriter II	COMPAQ DesqView 286 12 MHz 1.7 FD 40 MB HD DesqView 386 16 MHz 20 MB 25 MHz 60 MB 25 MHz 130 MB Port. 386 40 MB Port. 16-40 IBM System/2 Mod. 30 286HD Mod. 30 286HD 286 Processor Mod. 50-021 20 MB Mod. 50-230 20 MB Mod. 50-250 20 MB Mod. 50-44 20 MB Mod. 60-70 20 MB 386 Processor Mod. 70-120 20 MB Mod. 80-70 20 MB Mod. 80-115 20 MB Mod. 80-300 20 MB Mod. 80-300 20 MB LEADING EDGE 9-2 640K 1.12 MB F/D 30 MB HD 1099 3.2	PRINTERS Brother M-1109 Brother HR 20 Brother M-1709 Brother M-1724L Brother Twin Write 6 Diconix 150 Diconix 190 Diconix 300 W	EMERSON Epson FX-286C Epson FX-850 Epson FX-1050 Epson LO-850 Epson LO-1050 Epson LX-800 Fujitsu DL-3650 Fujitsu DL-3650 NEC P-2500 NEC P-5200 NEC CP-6 NEC CP-7 Oki 292 w/Modul Oki 293 w/Modul Oki 294 w/Modul Oki 320 Oki 321 Oki 350 Oki 391 Oki 393 Oki 393C Color Panasonic KXP-1080-1 Panasonic KXP-1091 Panasonic KXP-1092-1 Panasonic KXP-1524 Panasonic KXP-1525 Panasonic KXP-1595 Panasonic KXP-3151 Star M-1500 Star M-1740 Toshiba 341-5L Toshiba 351-5X	GRAPHIC CARD ATI VGA ATI VGA VIP Paradise VGA Prof. Paradise VGA Prof. Paradise EGA-480 Vega Vcl. 7 Data Vega VGA Logitech Mouse Logitech Wires Microsoft Mouse	LAPTOP Datavue Soarik EL 640K 40 MB NEC Multi Speed EL II Multi Speed EL II SHARP 450 1.1 3 1/4 F/D 450 2 3 1/4 F/D B/L 452 1 20 MB Backlit TOSHIBA T-1000 T-1200 F/D T-1200 Backlit. D/D T-1200 Backlit. 20 MB T-1200 20 MB T-1200 40 MB T-1500 386 Proc. ZENTH Z-184 1.2 F/D Z-184 2 20 MB Z-286 20 MB Z-286 40 MB Z-286 80 MB LASER PRINTER Apple Laser II HX Canon Series IF H.P. Desk Jet II NEC LC-850 Might US Rob. 1200-B Hayes 1200-B Hayes 2400 EXT. U.S. Rob. 2400 INT. Toshiba 2565 20 MB W/CD 30 MB W/CD 40 MB 20 M/5 Plus HC 20 MB Plus HC 40 MB Toshiba 310 D/iv	MONITORS Amdek 410 A Amdek 600 Color NEC MultiSync II Mitsubishi Scan NEC Multi-Plus POS Ultrasync Zenith 14" Flat FACSIMILE (FAX) Canon Fax 9 Canon Fax 20 Canon Fax 25 Sharp FO-300 Sharp FO-420 Sharp FO-500	SOFTWARE Excel IBM Project IBM Word IBM Word MAC Windows IBM Windows 386 IBM Works IBM PageView IBM PFS Profile IBM Managing money Dac Easy Act WordStar Pro 5.0 Turbo Pascal 4.0 Turbo C Norton Utilities D Base III Plus IBM Wordperfect 5.0 IBM Wordperfect MAC Lapline P. MAC Altus Page MAC Ventura IBM Cadd Loki Kick Plus Data Perfect Harvard Graphics Tape Backup Archival 40 MB
--	--	--	---	--	--	--	---

GUARANTEED LOWEST PRICES

1-800-874-1235

TOLL FREE OUT OF N.Y. : 1-800-874-1235

S & W COMPUTERS & ELECTRONICS

31 West 21 Street, New York, N.Y. 10010

Hours: Sun. 10-5, Mon-Thurs. 9-6, Fri. 9-2, Sat. Closed • Credit cards charged at time of order • N.Y. C.O.D. • Not responsible for type errors • Prices subject to change without notice • Returns w/out written authorization

ALL MERCHANDISE SHIPPED IN FACTORY SEALED CARTONS, 100% GUARANTEED



EPSON
(w/Nation-Wide Protection Plan)

EQUITY I+

- 360K Floppy
- 20 Meg Hard Disk
- 640K Ram
- Serial/Parallel Port
- Monochrome Card
- Monochrome Monitor
- MS DOS
- GW Basic

\$1295

EQUITY III+

- 80286 CPU 6-8 12 MHz
- 1.2 MEG Floppy
- 40 MEG Hard Disk
- DOS 3.2 Mono Monitor & Graphic Card

\$2195

EQUITY II PLUS

- 1.2 Meg Floppy
- 40 Meg Hard Disk
- 640K Ram
- Serial/Parallel/C/C
- 80286 CPU
- Monochrome Monitor
- Graphic Card
- MS DOS
- GW Basic

In order to provide the best service, EPSON EQUITY is exclusively sold on location.

LOW PRICE LEADER

SINCE 1983

Everex

- Step 286 - 12 & 16 MHz
- 1 Meg RAM
- Set up utility in ROM
- S/P, C/C
- Enhanced keyboard
- 1.2 MB floppy
- DOS/BASIC

Call for your configuration

Everex

- Step 386-20 MHz & 16 MHz
- 256K cache of very high speed RAM
- 2 Meg RAM, expandable to 16 Meg
- S/P, C/C
- Enhanced keyboard
- 1.2 MB floppy
- DOS/BASIC

Call

COMPAQ

- 386 S 40 Meg **3995**
 - 386 130 meg/20 MHz **6295**
 - 286 40 meg **2395**
 - 386 110 meg/25 MHz **7495**
 - 386 60 meg/20 MHz **5295**
 - Portable III 40 meg/12 MHz **4195**
- CARD & MONITOR EXTRA



- PS/2 model 30/20 meg **1775**
- PS/2 model 50/20 meg **2595**
- PS/2 model 60/40 meg **3395**
- PS/2 model 60/71 meg **4100**
- PS/2 model 80/40 meg **4595**
- PS/2 model 80/115 meg **6295**

LAP-TOP

- Toshiba S100-40 **4695**
- Toshiba 3200-40 **3595**
- Toshiba 3100-20 **Call**
- Toshiba 1000 **Call**
- NEC Multispeed **1295**
- NEC Multispeed EL **1595**
- EPSON LT **Call**

WE STOCK

CITIZEN
OKIDATA
EVEREX
GOLD STAR

TOSHIBA
NEC
WYSE
HITACHI

PRINCETON GRAPHICS
SONY
ACER
HOUSTON INSTRUMENTS

AMDEK
HAYES
SAMSUNG
CALCOMP

PC MOUSE
MICROSOFT MICE
LOGITECH
MITSUBISHI

IRWIN & ARCHIVE
TAPE BACK
TAXAN
MAGNOVOX

Macintosh

- Mac-SE/20 Meg **2595**
- Mac-II/40 Meg **3795**

ARCHE RIVAL 386

- 10/20 MHz, 1.2 floppy, 2 MB RAM
- Monochrome **\$3100**

SOFTWARE

- Microsoft Word **239**
- Word Perfect 5.0 **249**
- Lotus 1-2-3 **297**
- dBase III+ **385**

AND MANY, MANY MORE!

SPECIALS of the Month

- Microsoft Mouse **\$109**
- Microsoft Excel **\$299**
- Aldus Pagemaker **\$479**

AST

- AST 386 model 340 **4395**
- AST 286 model 80 **1595**
- AST 286 model 120 **Call**
- AST 286 model 140 **2595**

CARD & MONITOR EXTRA

EPSON® PRINTERS

- Epson FX850/1050 ... **\$379/535**
- Epson LQ850/1050 ... **\$559/785**
- Epson LQ500/2500 ... **\$359/895**
- Epson LX800/EX800 ... **\$199/445**
- Epson LQ2550 **\$970**

CITIZEN PRINTER

- 180D/15E **\$179/385**
- MSP210/45 **\$299/439**
- MSP50/55 **\$399/509**
- Tribute 124/224 **\$425/645**
- OverTune/Lazer **\$1459**
- HP LASER Jet II **1750**

WE ACCEPT LC, CASHIER CHECKS, MONEY ORDERS, VISA, MC, AmEx
3% charge on VISA, MC & 5% on American Express

COMPUTERLANE

HOURS:
M-S 9-6

1-800-526-3482 (Outside CA)
(818) 884-8644 (In CA)
(818) 884-8253 (FAX)

22107 ROSCOE BLVD.
CANOGA PARK
1/2 BLOCK W. OF TOPANGA
CA 91304

CORPORATE ACCOUNTS WELCOME
CALL FOR VOLUME DISCOUNTS
CONSULTANTS CALL FOR PRICING

Prices subject to change without notice

Compaq is a Registered Trademark of Compaq
IBM is a Registered Trademark of International Business Machines

BEST



NEW MINI PORTABLE BEST-286 LCD

- 10 MHZ 0 WAIT (12 MHZ Option)
- 512 K RAM
- 1.2 M. Floppy Drive
- 20 MB Hard Disk
- 200 W DC Fan Power Supply
- Serial & Parallel
- Non-Glare LCD Screen
- Super Twist
- Built-In Back Light
- 640 x 200 Dots
- Weight 22 lbs
- Padded Soft Carry Bag
- Dimension 16" x 8" x 9"

\$1600



VTI-33 SYSTEM

- 8088-2 10 MHZ
- 640 K RAM**
- 2 360K Floppy Drive
- Serial, Parallel Port
- Clock, Calender
- AT Style Keyboard
- Build in Mono/Color Graphic
- MONO MONITOR**
- MS-DOS 3.3, GW Basic

COLOR SYSTEM

\$749
\$919



BEST-286 PORTABLE

- 12 MHZ
- 512 K RAM
- One 1.2 MB Floppy Drive
- 7 Expansion Slots
- 200 W DC Fan Power Supply
- 9" Dual Amber Screen
- Mono or Color Graphic Card
- Serial & Parallel Port
- 84 Key Soft Tough Key Board

\$1115

BEST-88 PORTABLE \$845

386 SYSTEM

- 16 MHZ 80386 CPU
8/16MHZ
- 20 MHZ (Option)
- 80287 & 80387 Socket
- 1 M RAM
- One 32-bit, Five 16-bit,
Two 8-bit Expansion Slots
- 1.2 M Floppy Drive
- WA2 or NCL Control Card
- 3.5" Drive (Option)
- Tower Chassis

\$1995



VTI-55 SYSTEM

- 80286 12MHz
- 1 MB RAM**
- 1.2 MB Floppy Drive
- 30 MB Hard Disk (28 ms)**
with NCL Controller
- 2 Serial 1 Parallel
- Clock Calender
- 101 Enhance Keyboard
- ATI EGA Wonder Card
- EGA Monitor
- MS-DOS 3.3, GW Basic

\$1799

MONO SYSTEM \$1499

286 BABY MOTHER BOARD

- 10 MHZ \$265
- 12 MHZ \$295
- 8088 Mother Board \$95
- Mono Monitor \$79
- Fujitsu 102 Enhance Keyboard \$45

\$139

PORTABLE CASE

- 9" Dual Amber Monitor \$349
- 200 W Power Supply
- 9"Dual Amber Monitor \$329
- 150 W Power Supply

LCD CASE

- 640 x 200 Dots \$549

EGA PLUS 640 x 480
(Paradise Compatible)

CALL FOR QUANTITY PRICE

BEST

COMPUTER INC.
5017 Telegraph Road
Los Angeles, CA 90022

Tel: (213) 265-0900
Tech: (213) 265-0300
Fax: (213) 265-4234
Toll: **(800)634-7920**
Outside Cal.



MON - SAT 9:00 - 6:00 PACIFIC TIME
PRICE ARE SUBJECT TO CHANGE WITHOUT NOTICE

Circle 44 on Reader Service Card
(DEALERS: 45)

Credit Card Purchase Subject to Service Charge.



Parallel Processing Comes to PCs

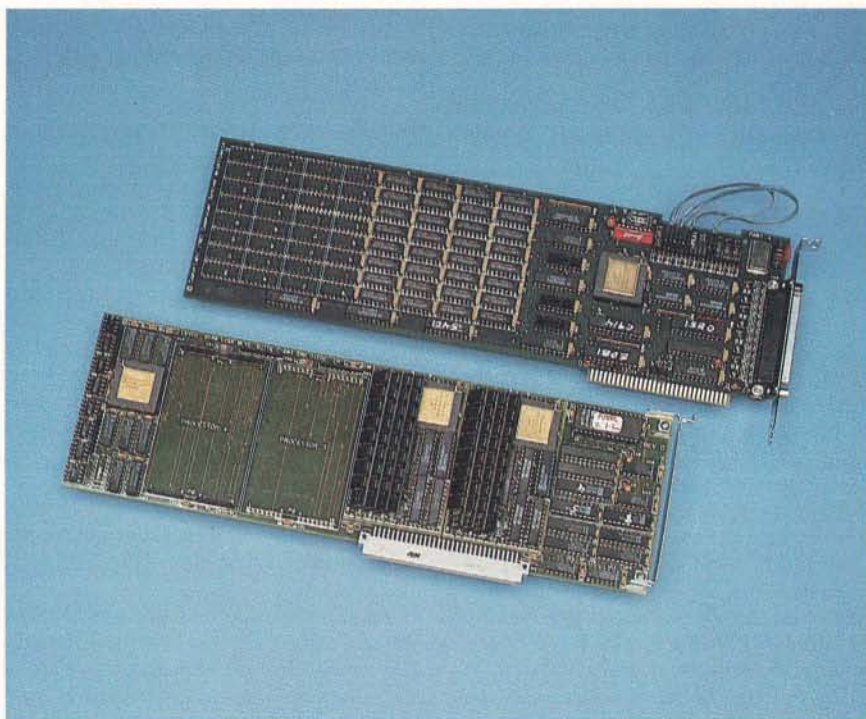

Transputer boards
boost the power
of your PC or Mac

Pete Wilson

It's the Holy Grail of computing: a system that gains computational power as you add processors and memory. And it's here today.

I reviewed two parallel-processing add-on products based on the INMOS transputer—one for IBM PC AT compatibles and one for the Macintosh II. These boards outperform the best available coprocessors, but that's almost beside the point. You can link transputers to create parallel—and expandable—networks and so boost the power of your favorite personal computer as a linear function of the dollars you invest.

These boards run few shrink-wrapped applications; in general, you have to port or develop software for them. So both companies—Computer System Architects (transputers for AT compatibles) and Levco (for the Mac II)—provide tools you need to develop parallel appli-

cations, and I'll look at those as well.

Computer System Architects (CSA) makes a series of boards based on transputers. I examined two boards based on the INMOS 20-MHz T800—one with 256K bytes of memory, and one with a megabyte—and a C-oriented development Toolset licensed from Logical Systems. Levco supplied a NuBus-compatible TransLink II card, two 20-MHz 1-megabyte T800 modules that plug into the TransLink II, the Logical Systems Toolset, and INMOS's TDS (Transputer Development System). The TDS comprises the tools you need to program concurrent systems in occam, the transputer's native parallel-programming language; though CSA doesn't provide the TDS, INMOS does, and you can use it with the CSA boards. It costs \$1750 to attach a CSA 1-megabyte T800 to an AT compatible, and nearly \$3000 to hook a Levco 1-megabyte T800 to a Mac II. Both CSA and Levco sell the Logical Systems Toolset for around \$400.

The Nature of the Beast

INMOS coined the word *transputer*. It refers to a device that integrates a reduced-instruction-set-computer processor, some memory, and a set of inter-processor communication links. INMOS manufactures a family of transputers. The T800 features a 32-bit integer processor roughly equivalent to a fast 80386 or a 68030, a 32-/64-bit IEEE floating-point unit (FPU) that's about twice as fast as a 68882 or an 80387, and four full-duplex serial I/O links driven by a dedicated eight-channel direct-memory-access (DMA) engine that can sustain 20 megabits per second in each direction on each link. Other components include a pair of timers (one ticking every microsecond, the other every 64 μ s), 4K bytes of fast (50-nanosecond) memory mapped to the bottom of the processor's 4-gigabyte address space, and a multitasking kernel in microcode.

continued

CSA PART.2, PART.4A, PART.S3**Type**

Multiprocessor hardware and software for PC, XT, and AT compatibles

Company

Computer System Architects
950 North University Ave.
Provo, Utah 84604
(801) 374-2300

Features

PART.2-820: T800-20 with PC DMA and 256K bytes of memory
PART.4A-820: T800-20 with PC DMA and 1 megabyte of memory
PART.S3: C compiler package (Transputer Toolset)

Hardware Needed

IBM PC, XT, AT, or compatible with a spare half-length slot (for the PART.2) or full-length slot (for the PART.4A), a hard disk drive, and 512K bytes of memory; Hercules, EGA, or CGA monitor needed for demonstration programs

Software Needed

MS-DOS 2.0 or higher

Documentation

1-page hardware installation guide; 220-page Transputer Toolset manual; 44-page Introduction to CSA PARTs and the Transputer

Price

PART.2-820: \$1225
PART.4A-820: \$1750
PART.S3: \$400
PART.2-820 and PART.S3: \$1295

Inquiry 886.

The T414 is a close cousin to the T800; it lacks the FPU and has just 2K bytes of on-chip memory.

To make a multiprocessor system, you configure transputer nodes into the topology of your choice. Then, of course, you have to program the collection. How easy is that? It depends. Some computing problems decompose naturally into concurrent subsystems; others don't.

Many graphical applications can benefit from the speed of an individual transputer and, when the elements of a display can be computed independently, from the ability to use transputers in parallel. Genigraphics uses CSA boards to enhance its illustration and video-animation software; Digital Arts demonstrated similar transputer-enhanced products at this year's SIGGRAPH. Levco supplies

a demonstration program that computes the Mandelbrot set in parallel.

Modeling and simulation also lend themselves to parallel processing. Neuronics markets a neural-net modeler called MacBrain; the transputer-based version of this product will have been released by the time you read this. Deutsch Research lent me a prerelease copy of its port of Spice 3.0, an industry-standard circuit simulator, in versions for a standard Mac II and a CSA T800. The T800 version simulated a small circuit nearly 12 times faster than the Mac II version. Since this circuit simulator isn't a true parallel application, the performance boost reflects the raw power of a single T800. (For more background on transputers and their capabilities, see "T800 and Counting" by Richard M. Stein on page 287.)

Using CSA Hardware with an MS-DOS Machine

The transputer boards need to talk to one another and to the host PC. Interprocessor communication is straightforward: CSA provides connections along the top edge of the boards, as well as a set of interconnect wires. You create the topology you want by attaching connecting cables to transputer links. (The links are clearly labeled on the board.) For electrical integrity, CSA uses differential buffers and receivers between the connectors and the transputers; that's unnecessary for short cable runs, but it gives you the flexibility to run substantial distances—for example, to transputers in another chassis.

To talk to the host, each board has another INMOS device called a link adapter. On one side, it resembles a parallel I/O port; on the other, it supports the INMOS link interface. Additional hardware makes the byte-wide side of the link adapter look to the PC as a DMA-accessible I/O port on the PC's bus; the link side connects to any of the transputer's links.

Using a simple protocol to communicate with a server program running on the PC, the transputer can share the host's screen, keyboard, and file resources. There's plenty of bandwidth between host and transputer. The CSA boards include DMA hardware that supports data transfer at 100K bytes per second (on an AT); that's somewhat faster than the best hard disk drives fitted to such machines.

Each board also has a switch you use to set the link adapter's bus address. In general, only one transputer needs a bus address; additional boards draw power

from the bus but communicate with each other and the host by means of the link hardware.

I installed the 1-megabyte board in a spare slot on my Tandy 3000 and ran the three test programs. One of the tests looks for link adapters on the bus; it found the correct single adapter at the default address 150 hexadecimal. Another test runs on the T800 and exercises its ability to read and write its own memory. A third checks the ability of the DMA machine in the link hardware (under control of messages sent through the links) to read and write the memory of a transputer module independently of the transputer's processor. All three tests ran successfully.

Transputing with the Tandy 3000

I decided to use the Transputer Toolset to port two nonparallel C programs that I've been working on—a SPARC assembler and a program that simulates the integer portion of a SPARC-based machine—to my transputer-equipped Tandy 3000. The Toolset includes the usual things: preprocessor and compiler (mostly compatible with ANSI C but with some private extensions), assembler, linker, and librarian. The preprocessor and compiler extensions are called *intrinsic*s—constructs that look like function calls but that the compiler can convert into in-line T800 instructions for things like string handling and bit-blinking.

The Toolset also includes some things you don't normally find: two loaders and a server. One of the loaders puts a nonparallel C program onto a single transputer; the other loads a collection of C programs onto a network of transputers; the collection of programs constitutes a parallel program. The server, which runs on the host, executes the protocol that enables programs running on the transputer to access the host's screen, keyboard, and file system. The transputer program issues standard C I/O calls that the library implements as calls to the server via the link adapter.

The command `install a c` worked as advertised; it copied files from the Toolset's three disks to directories on my hard disk. One subdirectory contained the obligatory "Hello, world" program along with a batch file that would preprocess, compile, assemble, and link the single source file. I ran the batch file; it produced a transputer-loadable (.TLD) file. To run that, I issued the command `ld_b004 chello cio`, which loaded "Hello, world" onto the transputer and loaded the server program onto the host.

Everything worked, and the transputer used the host's screen to announce its presence.

The Toolset provides two sets of library routines that you can use to parallelize C programs. These routines create processes and manage interprocess communication. One set implements the occam model, and the other supports the Unix fork/join model. I've programmed in occam, and I prefer it to the Unix model. If you don't already know occam, you may choose to avoid it, but be forewarned: The C constructs that support interprocess communication are not as intuitive as their occam counterparts.

A parallel program is really a collection of programs intended for a collection of computers. To run it, you have to supply the loader with a description of the network of processors. The Toolset's multitransputer loader operates on such a description, written as a .NIF (network information file) containing lines (one per node) of the form:

```
1, spice, R0, 2, 0, 2[1], 2[3];
```

In this example, the preamble 1, spice, R0 specifies that node 1 in the network will be loaded with the program spice and will be reset by node 0, the host. The remainder of the line describes how node 1's links are connected. Link 0 connects to node 2, link 1 to the host, link 2 to node 2's link 1, and link 3 to node 2's link 3.

Loading proceeds in phases. First, the loader distributes code to all the nodes, and it bootstraps the nodes with that code. Then the loader interprets the .NIF description and sends programs to the root node; from there, they percolate through the link hardware to their destinations. Normally, network problems turn up during the boot phase. If all else fails, CSA supplies an INMOS-written program called WORM that can wriggle its way around any collection of transputers and tell you what's connected to what.

My C programs, written in Megamax Laser C on an Atari Mega ST2 and an ST4, ported to the CSA system with no unusual difficulty. Of course, there were the normal problems you encounter when porting software. I had to remove some ST BIOS calls, substitute the Toolset Time() intrinsic for the equivalent Atari routine, take care of byte ordering (the 68000 is big-endian and views byte 0 of a word as most significant, but the T800 is little-endian), and change a compiler option to get sign propagation on arithmetic

right shifts. Once I fixed those things, both the SPARC assembler and the simulator ran correctly on the transputer.

On the ST, with an 8-MHz 68000, the simulator ran at about 90 simulated clock ticks per second; on the 20-MHz T800, it ran at about 450 clock ticks. That's five times faster, but since the 68000 is at best a 1-million-instruction-per-second machine and transputers are rated at 10 MIPS, you might wonder why the T800 version wasn't faster still. I think there are two reasons. First, the simulator uses lots of global variables, but the transputer's instruction set is optimized for local variables. Second, my simulator performs only integer operations, so it doesn't take advantage of the T800's floating-point capabilities.

To check that, I ported another program that analyzes simple linear circuits and is rich in floating-point work. On this test, the T800 ran 30 times faster than the Atari ST.

Using Levco Hardware with a Mac II

Levco handles multiple transputers in a different way than do the CSA products I reviewed. Instead of adding multiple boards to the host, it uses a single NuBus-compatible motherboard to which you can add plug-in modules. (Although I didn't review them, CSA offers multi-transputer boards, too.) The modules are small printed circuit boards (about 2 inches by 4 inches) with a standard pin-out that supports intermodule communication. Levco offers both T414- and T800-style modules; each comes in 256K-byte, 1-megabyte, and 4-megabyte flavors. Since Levco's modules follow the INMOS pin assignments, you should be able to mix the different styles and flavors on the motherboard; I couldn't check that since I was working with two identical 1-megabyte T800 modules.

The motherboard holds four modules. Levco uses a link crossbar switch (another INMOS part, the C004) to control the topological arrangement of modules on a board. Levco's Macintosh driver can find out the number and type of modules on a board, and it supports a protocol that applications can use to configure the links on each module. The crossbar switch doesn't work across motherboards, though, so you have to interconnect multiple motherboards yourself.

I installed a motherboard into a spare NuBus slot on my Mac II. It took some pressure to seat the two transputer modules, which plug into surface-mount sockets on the motherboard. Levco supplies a test program that exercises all the transputers found on a motherboard. The

Levco TransLink

Type

Multiprocessor hardware and software for Macintosh II

Company

Levco
6160 Lusk Blvd., Suite C100
San Diego, CA 92121
(619) 457-2011

Features

TransLink II: NuBus-compatible
Transputer motherboard
Module: T800-20 with 1 megabyte of memory
Transputer Toolset: C compiler package
TDS: Occam Transputer Development System

Hardware Needed

Macintosh II with spare NuBus slot;
hard disk drive

Software Needed

System 4.2/Finder 5.5 or higher;
Macintosh Programmer's Workshop

Documentation

16-page TransLink Installation Guide;
250-page Transputer Toolset manual;
650-page TDS manual

Price

Motherboard: \$799
Module: \$2199
Toolset: \$399 (purchased with hardware; \$499 separately)
TDS: \$1200
Macintosh Programmer's Workshop: \$225

Inquiry 887.

company suggests running the test for a while to make sure that all is well. I ran the test for a couple of hours; no problems appeared.

Like CSA, Levco offered a beta release of the Transputer Toolset. Levco's was an earlier version (88.2 rather than CSA's 88.3); however, by the time you read this, both companies will be offering the same final version. Because of the Toolset's command-line format, you need some sort of shell to use it on a Mac. Levco requires you to use the Macintosh Programmer's Workshop as that shell.

Levco has enhanced the Toolset with the facilities you need to build transputer-based programs that look on the host like standard Macintosh applications. To demonstrate this, the company includes a parallelized version of a

continued

Table 1: Transputer add-ons really make the PC fly.

	CSA 1-megabyte T800	Compaq 386/20	Macintosh II
Sieve*	6.31	23.18	40.2
Dhrystone*	9433	6321	2861
Whetstone**	4,005,000	1,759,199	606,060

* BYTE Small-C compiler was used for Compaq and Macintosh tests.

** MetaWare High C was used for the Compaq; Consulair Mac C was used for the Macintosh.

Note: Times for Sieve (100 iterations) are given in seconds; Dhrystones are in Dhrystones per second; Whetstones are in Whetstones per second.

Table 2: Allowing for differences in Toolset versions, the CSA and Levco boards exhibit similar performance.

	CSA/Toolset (88.3)*	Levco/Toolset (88.2)
Dhrystone	6310	5780
Whetstone	3,117,000	2,780,000

* Optimizations disabled.

Table 3: The penalty for multitasking on a single transputer is small, and it gets smaller as tasks get larger.

Number of tasks	Task duration			
	10	100	1000	10,000
Sequential				
100	2486	20,416	198,873	1,984,256
1000	24,876	203,203	1,988,636	19,842,524
10,000	247,796	2,032,946	19,886,994	198,425,216
Parallel				
100	3006	20,847	199,379	1,985,169
1000	29,387	208,228	1,993,347	19,851,050
10,000	300,054	2,084,401	19,936,349	198,513,081

Note: Task durations are in loop iterations; times are in microseconds.

gram to compute the Mandelbrot set. Commendably, Levco supplies two versions of source for this program—one in C and one in occam. The C version illustrates, among other things, how an application can use the Macintosh driver to configure transputer modules into a topology; the occam version shows how much simpler and prettier parallel programming is in a language designed for it. And when I ran the program on two modules, it did indeed run twice as fast as it did on one module.

Levco also supplies INMOS's occam-oriented Transputer Development System. Like the Transputer Toolset, Levco's TDS has extensions that you can use to create standard Macintosh interfaces to parallel applications.

The TDS is an integrated environ-

ment, like Megamax Laser C and Light-speed C. You've always got the editor handy; you compile from within the editor and it points out your errors; and there's built-in project management. TDS differs from the others in that it is essentially a programmer's outliner based on the notion of a *fold*. You can hide a chunk of code in a fold, and you can nest folds in other folds. For example, a procedure might live in a fold; inside that, all the declarations might be in one fold, and all the code in another. To do this, you mark the extent of the text you want to enclose in a fold and select create fold from the menu; an ellipsis—which you can annotate—replaces the text.

Folds are more than just textual conveniences. You wrap separately compilable

procedures in SC folds, single-transputer programs in EXE folds, and multitransputer programs in PROGRAM folds. The system uses the types of the folds to control compilation and linking.

The TDS comes with some sample programs—one that measures the time required to execute various programming constructs, and another that uses multiple processes to model diffusion. Both ran happily, though it was a bit of a shock to see the Macintosh report execution times in nanoseconds.

Unlike the Toolset, which runs on the host machine, the TDS runs on a transputer. It needs at least 1 megabyte of memory and prefers more. Given the horsepower, you might expect blinding speed. But an occam compiler has to work a lot harder than a C compiler; for example, it has to check that no variable is shared among parallel processes. It does the job, but don't expect Turbo C-like performance.

The TDS documentation includes Dick Pountain's excellent introduction to occam. Pountain assumes you know something about programming in a high-level language but nothing about programming parallel systems or about programming in occam, and he shows you how to do both.

Benchmarks

There's no BYTE Small-C compiler for the transputer (volunteers welcome), so I used the Toolset C compiler to compile and run the Sieve, Dhrystone, and Whetstone benchmarks on both of CSA's boards and on Levco's module. Because I was working with two different versions of the Toolset, (88.3 from CSA and 88.2 from Levco), I ran the tests twice. Table 1 shows the transputer in its best form—but only for the CSA hardware—relative to a Compaq 386/20 equipped with a 20-MHz 80387 and to a 16-MHz 68020 Mac II with a 68882. Table 2 supplements that with a CSA/Levco comparison that forfeits some of the optimizations available in version 88.3 to make for a fair matchup. Again, by the time you read this, both CSA and Levco will offer the latest version of the Toolset.

What do these figures mean? Taken at face value, they suggest that a single T800 can have four times the performance of a 20-MHz 80386 and six times that of a 16-MHz 68020 for integer work, or two to three times that of an 80386/80387 and six to seven times that of a 68020/68881 for floating-point work. A better way of looking at the ratios is to say that a single CSA board or

continued

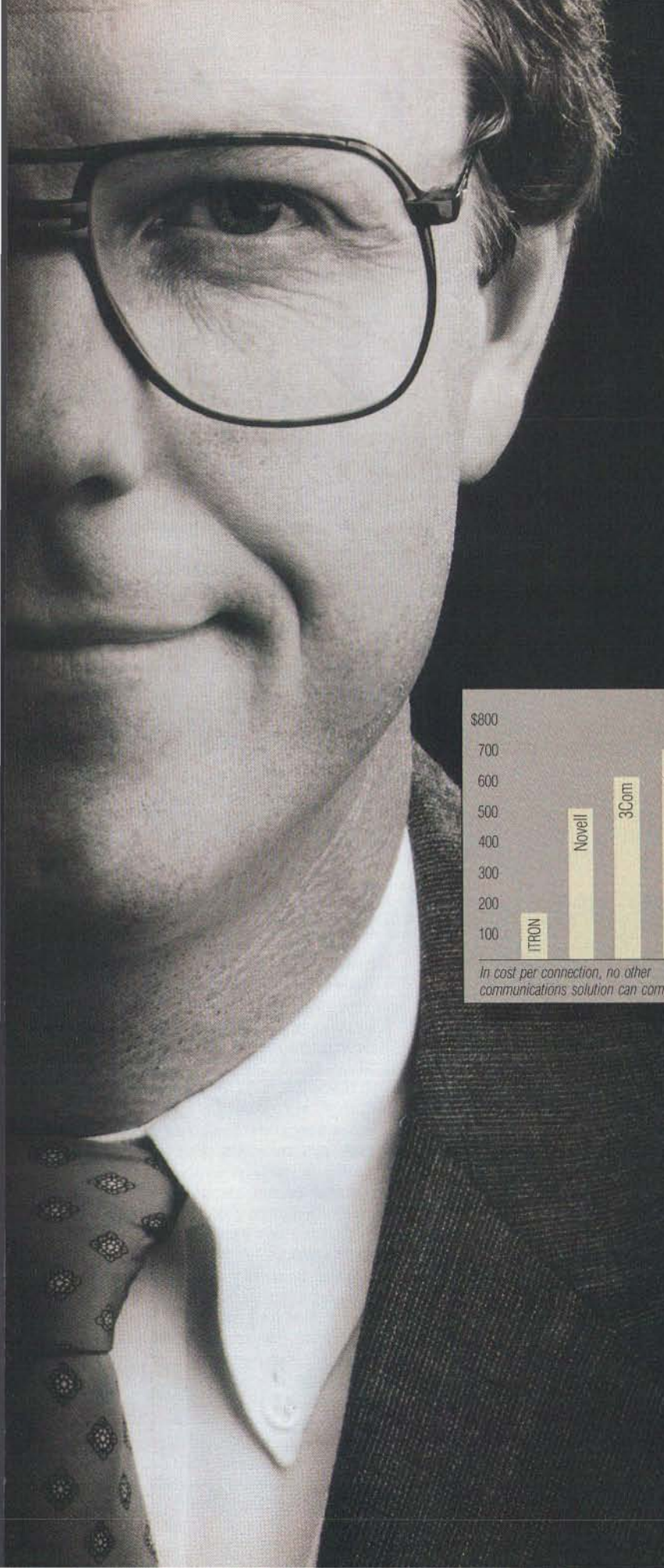

“The work groups in my department need to share printers. They need host connectivity, peer-to-peer file transfer and E-mail...

“But I don't need the complication and expense of a file server.”

Now there's Commix™ 32. For easy, fast communication between PCs, MACs, peripherals and minicomputer hosts. For as little as \$150 per connection.

You'll create a LAN where you can access a printer or modem right from your application program. Where file transfer and E-mail are background tasks. Where terminal emulation is automatic.

A LAN with hardware and software that expands. From a department, to a full-premise Ethernet® LAN, to a LAN/WAN inter-networking solution for ten users or a thousand.

It's not a file server. It's what you need. From ITRON:

800-423-8044
609-722-5575

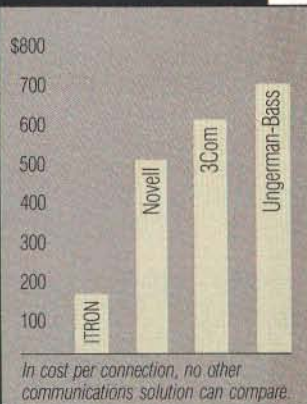

130 Gaither Drive, Suite 116
Mount Laurel, NJ 08054
FAX: (609)234-0451
BBS: (609)722-0639 (1200 8N1)
In the U.K.: (01)735-0731
In Brussels: (2)725-0770

Circle 169 on Reader Service Card

Some Things Never Change

*But now there's an easy way to
transport your 5 1/4" data to your laptop!*

WELTEC introduces their new 525 external floppy drive subsystem—the easy way to use 5.25" data with your 3.5" format laptop computer. The 525 subsystem is simple to setup, easy to use, and supports a wide variety of laptop and desktop systems.

For more information on the 525 subsystem write or call:

800-333-5155



WELTEC digital, inc.

17981 Sky Park Circle, Suite M, Irvine, CA 92714

Phone: 714-250-1959 • Telex: 3728057 • FAX: 714-250-1964

Levco module is twice as fast as a Compaq 386/20 for floating-point work, while with the BYTE Small-C compiler, the integer ratios are as shown. I suspect that with a good 80386 compiler—say, Metaware's—the T800 and a 20-MHz Compaq are about equal on a range of integer applications, and that each would outperform a Mac II by perhaps 2 to 1 on such work.

If you want to use transputers to their best advantage, you'll write process-oriented programs that run in parallel on multiple transputers but that multitask on systems with fewer than the maximum possible number of transputers. To get a feel for this, I used the Levco TDS to write a short occam program that runs tasks in two modes—serial and parallel—and varied both the number of tasks and the duration of each task.

Everybody knows that multitasking is inefficient. Creating and running a process can cost as much as several hundreds of procedure calls. (And try to create 10,000 tasks under OS/2 in a megabyte of memory!) But as table 3 shows, conventional wisdom doesn't hold for the T800. Parallel tasks on one transputer aren't much more expensive than serial ones, and that difference fades to insignificance as tasks grow larger. So you can afford to program in a parallel style, creating programs that can port to multitransputer configurations with the likelihood of a near-linear performance gain.

Summing Up

Both CSA and Levco offer full-fledged transputer development systems at a reasonable price. Should you buy one of these products to enhance your PC or Mac?

If you just want to run existing applications faster, then the answer is clearly no—transputers don't run most off-the-shelf programs yet. But if you develop your own software and you find yourself compute-bound (people in this category include scientists, engineers, and animators), then you should look very hard at these systems.

More generally, anyone interested in learning about parallel processing should take a close look at these products. What Pascal did for structured programming, transputers and occam promise to do for concurrency—and that's the future of computing. ■

Pete Wilson is a computer architecture engineer at Prisma, Inc., and lives in Colorado Springs, Colorado. He can be reached on BIX c/o "editors."

What is a Best Western?



The right place at the right price.

Make reservations at any Best Western, see your travel agent, or call toll-free

1-800-528-1234



"World's largest chain of independently owned and operated hotels, motor inns and resorts"

EXCEED THE LIMIT!

Microsoft
Mach 20
7.0

PCSG
Breakthru 286-12
8.7

Intel
InBoard 386 / PC
15.9

SOTA 286i
17.3

10

20

MHz

LANDMARK SPEED

(Equivalent to AT Running at X MHz)

Supports the IBM PS/2 Model 30, PC, XT—Compaq DeskPro, Portable—AT&T 6300—Tandy 1200—Zenith PC's and most 8088 or 8086 machines operating at clock speeds up to 10 MHz.

Fastest

The SOTA 286i is the fastest accelerator you can buy for your PC. Fastest, because it uses the latest VLSI technology to squeeze maximum performance from its on-board processor. Packing 80286 power into your personal computer the SOTA 286i delivers performance rivaling that of a new 386 machine. Twice as fast as an IBM AT, the SOTA 286i performs up to 15.3 times faster than an IBM PC-based on Norton SI.

Most Compatible

In fact, speed is just the beginning. The SOTA 286i is the only turbo board to earn the title **Universal Accelerator**. The same board that works in the IBM PC will also work in the Compaq DeskPro, AT&T 6300, PS/2 Model 30 and the list goes on. Not only that, the SOTA 286i is compatible with every ad-

on board in your system. Networks, video adapters, 3270 emulation boards all function flawlessly. And, the SOTA 286i fully supports the new EMS 4.0 memory standard. No other manufacturer offers this level of compatibility. No one!

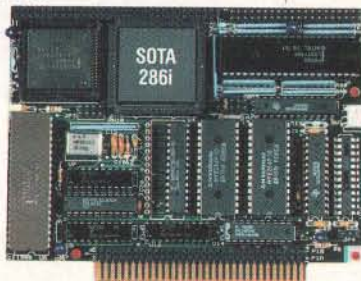

OS/2 Upgradeable

Included on the SOTA 286i is a 16-bit expansion connector for attaching such options as the Memory /16i. With its on-board RAM configurable as either EMS 4.0 or extended memory the Memory /16i is ideally suited for those new memory intensive programs. You can even run AT specific programs such as **IBM OS/2** and Professional ORACLE. A second feature connector is provided for the

Floppy I/O Plus. This multimedia disk controller supports both 3½" and 5¼" disk drives. It also contains both a parallel and serial port. A complete solution to your computing needs.

Outstanding Engineering

SOTA Technology has been acclaimed as a pioneer in the field of OS/2 compatibility. SOTA's first accelerator, the MotherCard 5.0, was the first and up until now — only product to run IBM OS/2 on a PC. It was nominated for product of the year 1987 in the field of technical excellence. The SOTA 286i is the next generation of accelerators from SOTA Technology. So why buy a product from our competitors that offers half a solution, when you can buy the **fastest**, most **compatible**, most **expandable** accelerator available. **The complete solution—the SOTA 286i!** See us at COMDEX Booth W144

SOTA
STATE OF THE ART TECHNOLOGY
SOTA Technology, Inc.

657 North Pastoria Ave., Sunnyvale, CA 94086
TEL: (408) 245-3366, FAX: (408) 245-0922

SOTA 286i is a trademark of SOTA Technology, Inc. All other products mentioned are trademarks of their respective manufacturers. SOTA 286i benchmark was run on IBM PS/2 Model 30.

Circle 313 on Reader Service Card

NOVEMBER 1988 • B Y T E 219

KANSAS CITY

More fountains than Rome and more boulevards than Paris: Kansas City will surprise you with its diversity, hustle, and charm

LET'S SEE, KANSAS CITY. NEW ORLEANS MEANS JAZZ AND NEW YORK GLITZY SHOPS, SEATTLE MEANS RAIN AND MIAMI SUN. Other cities are known for their dining, their arts, their historic interest. It may surprise you to learn that Kansas City is all these things and then some. With more fountains than Rome and more boulevards than Paris, this city is one of America's underrated travel destinations. From the symphony to the Chief's game, from gleaming shopping plazas to restored frontier stores, from art galleries to jazz nightspots—Kansas City is a smorgasbord of diversions. The city has clearly earned its nickname, "The Heart of America."

ARCHITECTURE A visitor to Kansas City can't help but be struck by the contrast between old and new, with the building boom of the last few years inserting steel skyscrapers next to century-old storefronts. But building booms are nothing new here, and the city sports an unusual array of fine 19th- and early-20th-century buildings. A casual walk through town reveals the architectural evidence of 130 years of vigorous growth. The highlight, especially for history buffs, is Westport, a lovingly restored trading village that was a major outfitting center for westbound travelers in the 1850s. Also of special interest is Country Club Plaza. Built in the 1920s and famous as the nation's first shopping center, it's a startling sight in the middle of a large Midwestern city: a collection of sumptuous buildings modeled after those in Seville, Spain, interspersed



plaza



The area's best example of late-19th-century Victorian architecture is some 10 miles from downtown, but worth the trip. It's in Independence, and it's the former home of President Harry S. Truman. Now under the stewardship of the National Park Service, the house is open to the public. And while you're in Independence, stop in the Truman Library for a look at the huge mural by Thomas Hart Benton in the lobby, entitled "Independence and the Opening of the West."



SHOPPING The star of Kansas City shopping is the Crown Center, an 85-acre "city within a city" built by Hallmark Cards. Crown Center offers 90 shops, department stores, and restaurants of every



THE CREATIVE SIDE OF PAGEMAKER.

There's only one desktop publishing program that's equally adept at producing stunning graphic design and powerful business reports.

It's Aldus PageMaker.® And it means desktop publishing to more people around the world than any other program.

For creative professionals, PageMaker offers powerful features for precise page composition,

document formatting, spot color, and text handling. All in a friendly, intuitive way.

For business professionals, PageMaker offers features like built-in templates and comprehensive support for long documents. It's the first desktop publishing program to run on both Macintosh® and PC computers. And it's compatible with more business software and peripherals than any other



Financial Report To Division Managers

The first quarter numbers are in . . .

	Three Months Ending		Six Months Ending	
	MARCH 31, 1988	MARCH 31, 1987	MARCH 31, 1988	MARCH 31, 1987
SALES				
U.S.	4,657,770	1,223,138	8,766,900	2,185,070
Europe	3,726,216	978,510	7,013,520	1,748,056
Asia	931,333	244,627	1,753,380	437,014
Net Sales	9,315,339	2,446,275	17,533,800	4,370,140
OPERATING EXPENSES				
Cost of sales	2,081,761	201,003	3,823,581	363,980
Selling, general, and administrative	3,644,439	971,806	6,959,683	1,690,362
Research and development	465,495	148,153	896,671	262,891
Income from operations	3,123,844	1,125,313	5,853,865	2,052,907
Equity in loss of K.C. operations	(158,915)		(218,134)	
Interest income	73,473	53,578	108,171	62,413
Income before federal income taxes	3,038,402	1,178,891	5,743,902	2,115,320
Provision for federal income taxes	1,135,000	511,000	2,175,000	911,000
Net income	1,903,402	667,891	3,568,902	1,204,320
Net income per share of common stock	\$0.17	\$0.06	\$0.31	\$0.11

...and they look very good.

In the first quarter of 1988 each division took advantage of strong economic conditions in their respective territories to post sales figures well in excess of their goals.

Rigorous cost cutting combined with the new distribution system have helped keep our operating expenses in line. Not including taxes increased 285% over the same period.

There is every indication that we will continue through the next quarter to do good work.

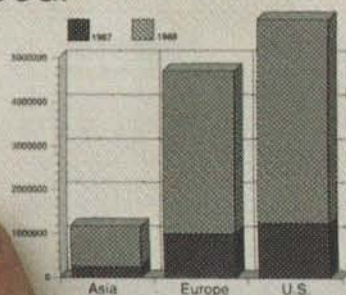

THE BUSINESS SIDE OF PAGEMAKER.

desktop publishing program available today.

Which explains why over 200,000 creative and business professionals around the world have chosen Aldus PageMaker.

To get a closer look at the creative and business sides of PageMaker, visit your authorized Aldus dealer, or call 1-800-33-ALDUS to order a \$4.95 self-running demo disk. Or you can order

a colorful videotape demonstration for just \$9.95.

In Washington state call (206) 628-2375.*



Aldus PageMaker®

411 First Avenue South, Seattle, WA 98104 (206) 622-5500.

*Offer good in U.S. and Canada only. The PC demo disk requires an IBM PS/2, PC AT, or compatible with EGA or VGA card and color monitor. The Macintosh demo disk requires an Apple Macintosh 512K Enhanced, Plus, SE, or II; at least 1 MB RAM; Apple System file 4.1 or higher; Finder 5.5 or higher.

Aldus, the Aldus logo, and PageMaker are registered trademarks of Aldus Corporation. Apple and Macintosh are registered trademarks and Finder is a trademark of Apple Computer Inc. IBM is a registered trademark and PS/2 is a trademark of International Business Machines Corporation. ©1988 Aldus Corporation. All rights reserved.

HARD DRIVES



Seagate

40Mb ST251

Includes drive, AT mounting hardware & "Disk Manager" partitioning software

\$339

Also available for XT

40Mb ST251 PC/XT KIT \$389

Includes drive, controller, cables, How-To manual, mounting hardware & partitioning software.

30 Day "Worry-Free" Guarantee

If for any reason, you are not completely satisfied with any product, simply return it for a prompt and courteous refund!

20Mb ST225 KIT

Complete PC/XT KIT includes drive, controller, cables, How-To manual & mounting hardware.

\$244

Seagate 150Mb KIT \$788

Complete kit includes drive, cables, Perstor ADRT controller, How-To Manual, mounting hardware and "Disk Manager" partitioning software. Full Height. 28ms access time.

30Mb

Complete ST238R PC/XT KIT

Complete PC/XT KIT includes drive, controller, cables, How-To manual & mounting hardware. **\$269**

Macintosh Drives

Internal drive kits are now available for Macintosh SE and II as well as external kits for Macintosh Plus, SE & II!

Call for pricing!

Drives and Kits are available for All PS/2 models!

We carry the entire Seagate product line including 3.5" drives

**Card Drive™
Hard Cards**

Card Drive 20S 40ms \$319
Card Drive 30S 40ms \$349
Card Drive 50S 40ms \$499

-- Features --

- Available for most Tandy models
- Quality engineered for reliability
- Super easy installation & setup
- ONE YEAR Warranty
- Auto park heads

These Card Drives use quality Seagate Hard Drives

65Mb ST277R

40ms access • Half Height
Autoparking heads
This drive requires an RLL controller

\$379

Includes drive, mounting hardware & "Disk Manager" partitioning software

**High Speed 40Mb
Seagate ST251-1**

28ms access • Half height • Auto parking heads
Also available for XT

\$409

Includes drive, AT mounting hardware & "Disk Manager" partitioning software



Help is just a phone call away with our Technical Assistance Department!

No Surcharge for Visa or MasterCard Orders

Hours: 8am to 7pm Monday - Friday, 12pm to 5pm Sat. MST

**HARD DRIVES
International**
An IDN Company

(800) 234-DISK

International Orders call: (602) 784-1038



1208 E. Broadway Road #110 • Tempe, AZ 85282

(602) 784-1038 FAX: (602) 829-9193

Toll Free Customer Service & Order Status: (800) 541-8387

Prices and availability subject to change without notice. All items are NEW with manufacturer's warranty. 5% surcharge for American Express and COD orders. P.O.'s accepted NET 10 - subject to 9% surcharge. Add \$19 shipping for APO/FPO orders. 30 Day Guarantee conditions: shipping & handling charge is not refundable; product must be in original condition. BYT1188



A C++ Toolkit

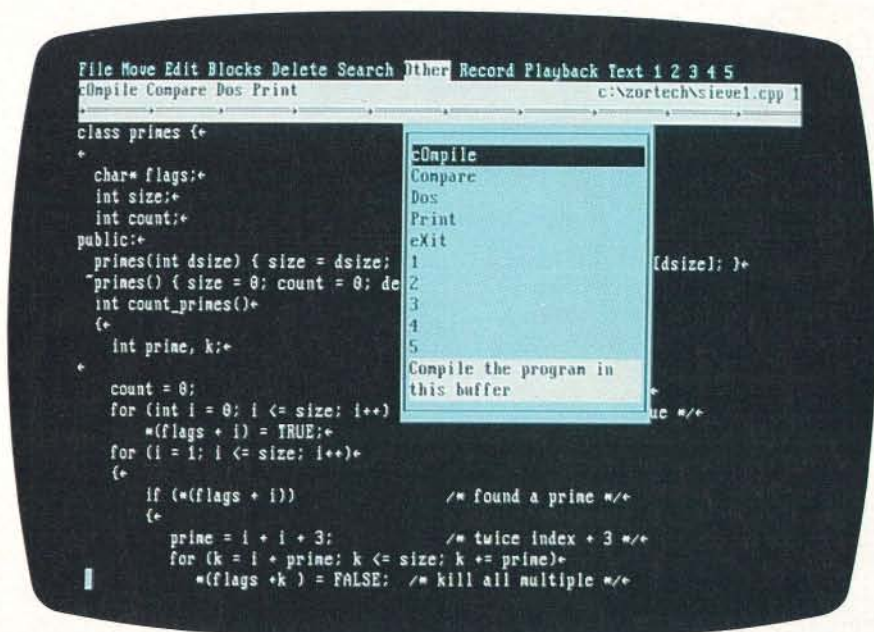

Everything you
need to get started
with C++

Jon Udell

Though it's 5 years old now, the C++ programming language has yet to achieve truly widespread acceptance within the microcomputing community. Zortech's C++ 1.0 compiler for IBM PCs (\$99.95) may soon change that. Note that it is a compiler, not (as is usually the case) a translator that you use in conjunction with a C compiler. Zortech's C++ conforms closely to the definition of AT&T C++ as set forth in Bjarne Stroustrup's *The C++ Programming Language*. In addition to the compiler, the package includes an impressive collection of programming tools: an optimizer, a linker, a librarian, a disassembler, an editor, a make facility, a help system, a set of ANSI C libraries, and a graphics library.

The installation program is easy to use, but inflexible. Hard-wired to copy the contents of eight distribution disks to a directory tree at the root of drive C, it won't let you install to a subdirectory of

drive C or to another drive. That was particularly annoying in my case, because I have two hard disks, drive C and drive D, and I wanted to install the package on drive D. I ended up doing it the hard way—I installed on drive C first, then moved everything to drive D. I hope Zortech corrects this in the next release. Commendably, Zortech makes available two additional disks containing source code in assembly, C, and C++ for the Zortech run-time libraries (excluding the graphics library); the library source code costs another \$50.

Tools of the Trade

There are so many tools here that it takes a while to just sort them out—there are seven compilation tools and two linking tools. The organization of the compiler accounts for some of this complexity. It runs in two passes—ZTCPP1.EXE produces an intermediate representation, and ZTC2.EXE converts that into object code. If you choose to optimize, compilation becomes a three-pass affair; you run ZTG.EXE on the intermediate representation before feeding it to the code generator. Zortech's decision to provide a stand-alone C compiler adds more complexity. The C and C++ compilers share the same optimizer and code generator. But for C-only compilations, you can use ZTC1.EXE as the front end instead of ZTCPP1.EXE.

ZTG performs an extensive set of optimizations. It propagates constants; eliminates dead assignments, dead code, and dead variables; hoists loop-invariant expressions; and merges common sub-expressions. You can choose to optimize for speed or size. By default, ZTG attempts all optimizations (favoring speed over size); you can selectively disable particular ones.

Zortech's manual, which compares the performance of Zortech C++ to that of Turbo C 1.5 and QuickC 1.0 on standard C benchmarks, cites the results of

continued

We'll take your stats and make you the most valuable player in your league.



★

CHRIS JOHNSON Data Analyst

CAREER HIGHLIGHTS

1983
Proposed remap of sales territories based on SPSS analysis of economic and consumer trends. Increased new-customer revenues 38% in 2 years.

1985
Used SPSS data entry/tabulation system to administer employee benefits more efficiently. Eliminated outside costs of more than \$75,000.

1986
Identified current customers likely to need added services, increasing average billings by more than 20%.

1988
Rewarded with special corporate recognition and bonus.

★ Another Story in the SPSS SUCCESS SERIES ★

Data analysis software from SPSS® gives your PC a winning advantage.

It doesn't matter which field you play hardball in. The right combination of equipment and ability can make you a hero.

You get that ability with SPSS/PC+™, the best-selling data analysis software from SPSS. It's designed for the IBM PC/XT™, PC/AT™, PS/2™ and compatibles. And with it, you'll turn raw data into real facts, for sound business decisions.

SPSS/PC+ features a base package of numerous statistical procedures. Plus some

powerful options for data entry, advanced statistics, forecasting, graphics, mapping and much more. So you can scrutinize and manipulate your data in countless ways.

SPSS/PC+ also provides a seamless interface with other popular PC software such as dBase™ and 1-2-3™ to give you complete command of your data. For market research, sales analysis, quality control and much more.

Yet, SPSS/PC+ is designed for ease-of-use. It features a menuing and help system, as well as an on-line statistical glossary that helps you interpret results as you go.

And you'll always have training, support,

and ongoing upgrades from SPSS. The team that's supplied statistical software to over 1 million users since 1968.

For more details on how SPSS/PC+ can help you get the most out of your micro, give us a call at

1-312-329-3315.

We'll show you how to really stand out in your field.

SPSS inc.

Best in the final analysis.

444 North Michigan Avenue • Chicago, Illinois 60611

SPSS is a registered trademark of SPSS Inc. SPSS/PC+ is a trademark of SPSS Inc. IBM PC/XT, PC/AT and PS/2 are trademarks of International Business Machines Corporation. dBase is a trademark of Ashton-Tate. 1-2-3 is a trademark of Lotus Development Corporation.

Zortech C++ 1.0

Type
C++ compiler

Company
Zortech, Inc.
366 Massachusetts Ave.
Suite 303
Arlington, MA 02174
(800) 848-8408
(617) 646-6703

Format
Eight 360K-byte floppy disks

Language
C

Hardware Needed
IBM PC or compatible with 512K bytes of memory, a floppy disk drive, and a hard disk drive

Software Needed
MS-DOS 2.0 or higher

Options
Library: \$50

Documentation
572-page bound manual

Price
\$99.95

Inquiry 884.

an unoptimized run of the floating-point test, because the optimized run wasn't a fair comparison—Zortech's optimizer simply eliminated the computations. I compiled the floating-point test with Zortech's tools, with and without optimization, and disassembled the object files. The optimized version simply loads and prints a floating-point constant, which the optimizer determined to be computable at compile time. Oddly, it retains an enclosing loop; the Microsoft C 5.1 compiler eliminates that too.

Zortech provides a linker, LINK.EXE, but doesn't require that you use it. And if you want to debug C++ programs with CodeView, you can't use Zortech's linker. You have to use the Microsoft linker and then run a curious utility called BUNCH.EXE, which patches your .EXE so that constructors and destructors will work properly.

You can use .BAT files to control the invocation of the compilation and linking tools, or you can use the master control program ZTC.COM. Given a mixture of .C, .CPP (C++), .ASM, .OBJ, and .LIB files, ZTC selects the right tools in

the right order, distributing its command-line arguments to the right places. Through ZTC, you can turn off prototyping, define macros, generate in-line 8087 or 80287 instructions, request insertion of line numbers into the object file, specify the memory model you want, specify stack size, request optimization, link for CodeView, and run BUNCH. If you alternate between two linkers—Zortech's and Microsoft's—you'll run into a minor problem. Since the two linkers share the same name, ZTC grabs the first one on the path; you may need to fiddle with your path to ensure that you use one or the other.

Finally, you can use make to control ZTC, or to control the compile and link tools directly. It operates on a text file (make file) that specifies a set of outputs, the inputs on which those outputs depend, and the actions required to convert the inputs to outputs. Zortech's make supports standard syntax and features.

Shades of Borland

In many respects, the Zortech package invites comparison with Borland's language products. It's an inexpensive and fast compiler that aims to popularize C++ in much the same way that Borland popularized Pascal and Prolog. Zortech's editor, in particular, strongly resembles the one that comes with Borland products. Like Borland's editor, Zortech's integrates with the compiler so that when you compile from within an edit buffer, the compiler halts when it encounters an error, and the editor displays the error message and positions you on the offending line of code. And like Borland's editor, it uses a WordStar-like command set. Zortech also mimics the reconfiguration capability of the Borland editor (i.e., the ability to map edit functions to alternate keys, in case you prefer something other than the WordStar key mapping). But the Zortech editor is less reconfigurable than Borland's; you can't attach commands to multikey combinations, so you can't emulate editors that use such combinations. You can use your own editor instead of Zortech's.

Zortech's C++ comes with a graphics library that's similar to the Borland Graphics Interface, though less comprehensive. Both support basic operations like drawing lines (in varying thicknesses and styles), arcs, and boxes, and writing text in graphics mode; both can adapt their use of color to the palette at hand. But Zortech's graphics library doesn't support advanced features of the BGI, such as viewports, polygons, fill

continued

The best
Modula-2

compilers for PCs and compatibles

Taylor Modula-2

The professional high-performance compiler for PCs: the fastest compiler in the world!

- * **unrivalled speed of compilation**
7,000-10,000 lines per minute (80286, 8 MHz).
- * **excellent code**
Mini-computer standard global optimisation. Code performs 1580 Dhrystone tests per second! (80286, 8 MHz)
- * **ultra-compact**
high code density and a library of unrivalled compactness (23 modules in a total of 13k!)
- * **completely standard implementation**
Follows N. Wirth's standard for Modula-2. BIOS independent - uses MS/PC DOS exclusively.
- * **easy to use**
Straightforward user interface. Comprehensive documentation for system programmers.
- * **Guarantee and support**
One year guarantee. Maintenance contracts available. Swiss quality product.

TaylorModula-2 **\$ 900**
Demo disk **\$ 10**

M2SDS **\$ 99**

The professional Modula-2 software development system M2SDS comprises the following features in an easy-to-use window environment:

- modern, syntax-driven editor
- fast compiler
- linker producing EXE programs
- unique library manager
- comprehensive standard library

There are a vast number of tools, toolboxes, demo disks, public domain programs and books for M2SDS - probably more than for any other development system! M2SDS was used for the writing of the Farsight integrated business software package!

Demo disks **\$ 10**

JPI-Modula-2 **\$ 149**

A reasonably-priced Modula-2 compiler with a configurable environment, integrated Make function and highly optimising code generator.

We have Modula-2 compilers for the Amiga, HP9000/300, IBM/370, OS-9 and Sun. The list is constantly growing!

Texas residents add 6% sales tax. International Orders add \$ 2.00 shipping.

The Modula-2 people:



3336 Richmond, Suite 323
Houston, TX 77098-9990 (713) 523 8422

Dealer inquiries welcome

International	
Austria: 0222/4545010	United Kingdom: 01/6567333
Belgium: 071/366133	Germany: 02983/8337;
France: 20822662	0731/26932;
Italy: 02/405174	0821/85737;
Scandinavia: +45/3/512014	04106/3998;
Switzerland: 01/9455432	0531/347121



A. + L. Meier-Vogt
Im Späten 23
CH-8906 Bonstetten/ZH
Switzerland
Tel. (41)(1) 700 30 37

See C Writer.

Herb Schildt is the author that over 600,000 programmers turn to for the word on languages. That's because Schildt's expertise in programming is unprecedented. And he is unsurpassed in C. In fact, out of the 21 books Herb's published, all 9 of his books on C are bestsellers. Find out why over 600,000 programmers can't be wrong. **See C Writer, Herb Schildt.**

"Schildt's books offer first rate material"
Computerworld

"... Noted author and veteran C programmer ... produce(s) the kind of book programmers like best ..."
Philippe Kahn, President, Borland International, Inc.
From the Foreword of *Using Turbo C*

C: The Complete Reference \$24.95, ISBN 0-07-881263-1

C: Power User's Guide \$22.95, ISBN 0-07-881307-7

Artificial Intelligence Using C \$21.95, ISBN 0-07-881255-0

Advanced C, Second Edition \$21.95, ISBN 0-07-881348-4

Turbo C: The Complete Reference \$24.95, ISBN 0-07-881346-8

Turbo C: The Pocket Reference \$5.95, ISBN 0-07-881381-6

C: The Pocket Reference \$5.95, ISBN 0-07-881321-2

Using Turbo C \$19.95, ISBN 0-07-881279-8

Advanced Turbo C \$22.95, ISBN 0-07-881280-1

Just Released-

OS/2™ Programming: An Introduction

\$21.95, ISBN 0-07-881427-8

For a Free Catalog with More Information on All 21 Books
Written by Herb Schildt

Call Toll-Free 800-227-0900

Visa, MasterCard, American Express Accepted for Orders.
Include local tax and \$2.00 for shipping.



Osborne McGraw-Hill
2600 Tenth Street
Berkeley, California 94710

Trademarks: OS/2 is a trademark of International Business Machines Corp.
Turbo C is a registered trademark of Borland International, Inc.
Copyright © 1988 McGraw-Hill, Inc.

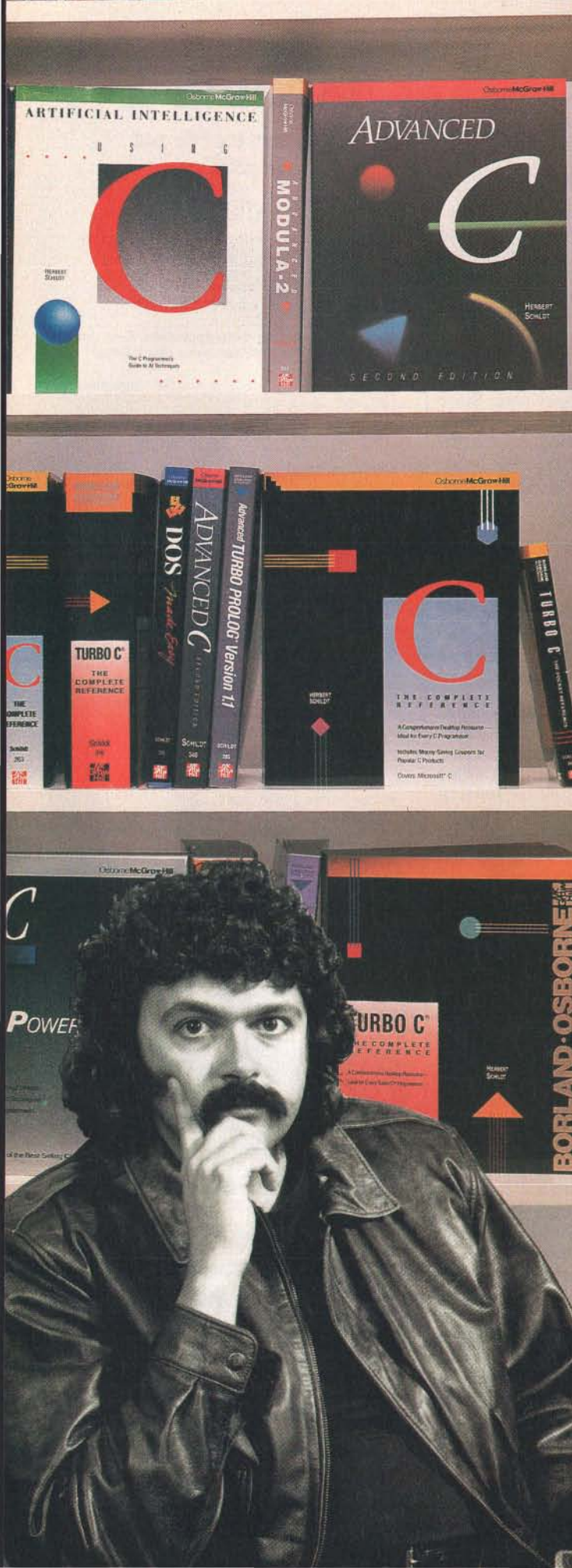

Table 1: Zortech C++ compiles and links faster than the combination of Advantage C++ and Microsoft C 5.1, but Advantage has a slight edge at run time. File sizes are in bytes; times are in seconds.

Test	Compiler	Source	.OBJ	.EXE	Comp+Link	Run time
Sieve	Zortech	1219	672	11,057	5	7
	Advantage	1219	643	7457	8	6
Complex	Zortech	1645	1440	11,699	6	8
	Advantage	1645	19,579	15,148	12	6

patterns, flood filling, and scalable stroked-character fonts, and its documentation is inferior to Borland's. On the other hand, although Zortech's graphics library is C-oriented, you can embed those routines in object-oriented C++ code of your own devising; that should be quite useful if you're developing complex graphical applications.

Zortech would do well to imitate another Borland tradition. Borland's language products always come with at least one substantial piece of working code that beginners can use to get up to speed. Zortech provides a few C examples (e.g., a word counter, a file dumper, and a graphics demo), and, if you buy the library source code, you can see how Zortech has used C++ to implement the classes `istream` and `ostream`. But the basic package provides nothing in C++.

The Zortech context-sensitive help system has no counterpart in the Borland products. It's a terminate-and-stay-resident program that retrieves information about Zortech tools, and about C++ generally, from within Zortech's (or another) editor. You position the cursor on the word you want described and press the hot key (Alt-H by default); up pops a screen containing a description. Unfortunately, it's a pretty simpleminded system. If the word is `class`, you'll see a description of what a class is in C++ and how to declare one. But if the word is `istream` (the predefined C++ class that implements the concept of an input stream), you'll see the declaration for the C library function `islower`—worse than no response at all.

Fast Compilation

The BYTE Lab compared Zortech C++ to Lifeboat's Advantage C++, using C++ versions of the Sieve and complex math benchmarks. Since Advantage C++ is a translator, we ran its output through the Microsoft C 5.1 compiler. The benchmarks were run on a Dell 310 with an 80386 processor, 640K bytes of

memory, a hard disk drive, and an 80387 coprocessor. We configured both Advantage and Zortech to optimize and to use the 80387.

The C++ version of the Sieve program embeds its array of flags in a class definition, defines a constructor to allocate it and a destructor to free it, and defines a member function to traverse the array and count primes. The complex math program defines a complex-number class and uses the operator-overloading capability of C++ to associate complex assignment, multiplication, and division functions with the symbols `=`, `*`, and `/`.

Not surprisingly, Zortech's integrated compiler works faster than the Lifeboat/Microsoft hybrid (see table 1). Once compiled, though, the Lifeboat/Microsoft programs have a slight performance edge over the Zortech versions.

Programmers who write in C for IBM PC and compatible hardware and who want to learn and apply object-oriented techniques will find Zortech's C++ compiler very attractive. There is room for improvement: The installation program lacks flexibility, the graphics routines are poorly documented, the help system frequently gives erroneous results, and the package provides few examples of working C++ code.

But Zortech C++ compiles in a hurry; it produces efficient object files; you can use it in conjunction with a third-party debugger like CodeView; it is compatible with both the draft ANSI C standard and AT&T C++; it provides a complete development environment; and it doesn't cost a lot of money. Those are powerful incentives to jump on the C++ bandwagon.

Editor's note: *The C++ source code for the benchmarks is available in a variety of formats. See page 3 for details.* ■

Jon Udell is a BYTE technical editor. He can be reached on BIX as "judell."

Tools and Toolboxes Modula-2

Applications Generator

Amadeus \$395
Generate Modula-2 programs directly from your own input, and save yourself hours of coding!

Graphics

M2Graph* \$65
Controls Hercules cards in Modula-2.

M2EGA* \$65
Controls EGA cards in Modula-2.

Modula Graphics Toolbox I* \$112
A collection of extremely fast graphics routines for CGA cards written in Modula-2.

Modula Graphics Toolbox II* \$188
Comprehensive package of Modula-2 procedures for all currently available graphics cards. Includes graphics window system, font generator, sprite handler, mouse driver, maths routines, as well as pie chart, histogram and line graph functions etc.

Input/Output

LCR-Window Manager* \$133
Fast, compact window system.

M2Windows* \$188
Fast, professional window system. Small, high-performance library with integrated menu system and simple mask generator.

Modula Mask & Menu Generator* \$360
Development system for creating masks and menus in Modula-2 source code. Mask, menu and frame editor. Supports all colours and attributes.

Other Tools

M2 Prolib \$495
The professional library

B-Tree ISAM \$290
Ultra fast database

Pascal-Modula Converter \$59
Converts Turbo-Pascal to Modula-2.

RTA-Utility Disk \$30
2-10x faster I/O, extended MathLib.

EMS-Utilities* \$188
Make full use of your Megabytes of memory expansion.

M2IEEE-Interface* \$144
Modula-2 interface to National Instruments IEEE Interface.

This is only a small selection from our comprehensive list of tools for Modula-2. Demo disks are available for products marked with an asterisk. Send \$10 for three demo disks, \$20 for seven. There is also a wide choice of books and literature on Modula-2.

We have Modula-2 compilers for the Philips 80386, 80486, 387, 487, 586, 587, 68000, 68010, 68020, 68030, 68040, 68050, 68060, 68070, 68080, 68090, 68010, 68020, 68030, 68040, 68050, 68060, 68070, 68080, 68090.

For more information, contact us at the address below.

The Modula-2 people:



INTERFACE TECHNOLOGIES

3336 Richmond, Suite 323
Houston, TX 77098-9990 (713) 523 8422

Dealer inquiries welcome

International

Austria: 0222/4545010

Belgium: 071/366133

France: 20822662

Italy: 02/405174

Scandinavia: +45/3/512014

Switzerland: 01/9455432

United Kingdom: 01/6567333

Germany: 02983/8337

0731/26932

0821/85737

04106/3998

0531/347121



A. + L. Meier-Vogt
Im Späten 23
CH-8906 Bonstetten/ZH
Switzerland
Tel. (41)(1) 700 30 37



QNX vs. OS/2 UNIX

QNX®: Bend it, shape it, any way you want it.

ARCHITECTURE If the micro world were not so varied, QNX would not be so successful. After all, it is the operating system which enhances or limits the potential capabilities of applications. QNX owes its success (over 60,000 systems sold since 1982) to the tremendous power and flexibility provided by its modular architecture.

Based on message-passing, QNX is radically more innovative than UNIX or OS/2. Written by a small team of dedicated designers, it provides a fully integrated multi-user, multi-tasking, networked operating system in a lean 148K. By comparison, both OS/2 and UNIX, written by many hands, are huge and cumbersome. Both are examples of a monolithic operating system design fashionable over 20 years ago.

MULTI-USER OS/2 is multi-tasking but NOT multi-user. For OS/2, this inherent deficiency is a serious handicap for ter-

minal and remote access. QNX is both multi-tasking AND multi-user, allowing up to 32 terminals and modems to connect to any computer.

INTEGRATED NETWORKING Neither UNIX nor OS/2 can provide integrated networking. With truly distributed processing and resource sharing, QNX makes all resources (processors, disks, printers and modems anywhere on the network) available to any user. Systems may be single computers, or, by simply adding micros without changes to user software, they can grow to large transparent multi-processor environments. QNX is the mainframe you build micro by micro.

PC's, AT's and PS/2's OS/2 and UNIX severely restrict hardware that can be used: you must replace all your PC's with AT's. In contrast, QNX runs superbly on PC's and literally soars on AT's and PS/2's. You can

run your unmodified QNX applications on any mix of machines, either standalone or in a QNX local area network, in real mode on PC's or in protected mode on AT's. Only QNX lets you run multi-user/multi-tasking with networking on all classes of machines.

REAL TIME QNX real-time performance leaves both OS/2 and UNIX wallowing at the gate. In fact, QNX is in use at thousands of real-time sites, right now.

DOS SUPPORT QNX allows you to run PC-DOS applications as single-user tasks, for both PC's and AT's in real or protected mode. With OS/2, 128K of the DOS memory is consumed to enable this facility. Within QNX protected mode, a full 640K can be used for PC-DOS.

ANY WAY YOU WANT IT QNX has the power and flexibility you need. Call for details and a demo disk.

THE ONLY MULTI-USER, MULTI-TASKING, NETWORKING, REAL-TIME OPERATING SYSTEM FOR THE IBM PC, AT, PS/2 THE HP VECTRA, AND COMPATIBLES

Multi-User	10 (32) serial terminals per PC (AT).	C Compiler	Standard Kernighan and Ritchie.
Multi-Tasking	64 (150) tasks per PC (AT).	Flexibility	Single PC, networked PC's, single PC with terminals, networked PC's with terminals. No central servers. Full sharing of disks, devices and CPU's.
Networking	2.5 Megabit token passing. 255 PC's and/or AT's per network. 10,000 tasks per network. Thousands of users per network.	PC-DOS	PC-DOS runs as a QNX task.
Real Time	3,200 task switches/sec (AT).	Cost	From US \$450. Runtime pricing available.
Message Passing	Fast intertask communication between tasks on any machine.		



For further information or a free demonstration diskette, please telephone (613) 591-0931.

Quantum Software Systems Ltd. • Kanata South Business Park • 175 Terrence Matthews Crescent • Kanata, Ontario, Canada • K2M 1W8
See us at COMDEX FALL '88 November 14-18 1988 Las Vegas, Nevada. Booth #H7044, Hilton Center

QNX is a registered trademark of Quantum Software Systems Ltd.

UNIX is a registered trademark of AT & T Bell Labs. IBM, PC, AT, XT and PS/2, PC-DOS and OS/2 are trademarks of International Business Machines. HP and Vectra are registered trademarks of Hewlett-Packard Company.



Lint for the PC

PC-Lint Vers. 2.15, Copyright Gimpel Software 1985-1988

```

---- Module module1.c
      return (x-32) * 5.0 / 9.0$;
module1.c 9 Warning 524: Loss of precision
module1.c 9 Warning 533: function cent -- return mode inconsistent
      with line 7
      x = cent( $atoi( argv[1] ) );
module1.c 24 Informational 718: atoi undeclared this module, assumed to return
      int
module1.c 24 Warning 516: function cent: arg. type conflict (Arg. no. 1)
      with line 8
module1.c 24 Warning 534: function cent -- return mode inconsistent
      with line 7
      $printf( "centigrade = %f\n", x );
module1.c 25 Informational 718: printf undeclared this module, assumed to retu
      rn int
module1.c 25 Warning 559: size of argument no. 2 inconsistent with format
      $)
module1.c 26 Informational 715: argc (line 19) not referenced
Warning 526: printf (line 25) not defined
Warning 526: atoi (line 24) not defined
Informational 714: main (line 19) not referenced

C:\LINT>_

```

An MS-DOS version of the Unix tool

Alex Lane

The C programming language enjoys tremendous popularity these days. Tools associated with programming in C, like make and lint, have accompanied the language in its migration from Unix to MS-DOS. PC-Lint 2.15 (\$139) is one PC-based implementation of Unix lint—a program that reads C source code before you compile it in search of what PC-Lint's manual describes as “quirks, idiosyncrasies, glitches, and bugs.”

C derives its power, in large measure, from the uniformity of its rules for form-

ing expressions; programmers like to refer to this property as orthogonality. But C's orthogonality is a double-edged sword. It supports nearly unlimited flexibility and elegance of expression; it also lets programmers make silly mistakes. Here's one kind of mistake that C compilers don't prevent and that lint was designed to catch:

```

int dumb_function() {
    return (3.1415);
}

```

This function's declaration announces a return type of int, but its body returns a value of type float. The lint programs guard against these and other kinds of errors that invalidate programs, hinder portability, or simply waste resources.

PC-Lint isn't the only version of lint for the PC market. Phoenix Technologies, for example, offers a lint program called Pre-C. All the PC-based lints find themselves in competition

with C compilers that provide lint (e.g., Wizard C) or warning (e.g., Microsoft C) features. I'll compare PC-Lint to Microsoft C 5.0.

Out of the Box

PC-Lint requires a relatively minimal setup: an IBM PC (or compatible) with MS-DOS 2.0 or higher and 128K bytes of memory (though the manual notes that you might need 192K bytes for “satisfactory operation”). I tested the program on a 16-MHz ARC 386i equipped with 512K bytes of memory and a hard disk drive.

There's nothing fancy about installing PC-Lint. You can run it directly from a backup floppy (saving about 100K bytes on your hard disk), or copy all the files from the distribution disk to your hard disk and run it from there. In addition to LINT.EXE, the package includes a number of test files, a selection of standard library definition files that work with different compilers, and a print utility that paginates and prints one or more files with or without headers, footers, and line numbers.

Getting Started

You can use PC-Lint right out of the box even if you haven't a byte of C source code available. It comes with two sample source files that you can use to test the program. Other sample files include indirection files (.LNT files containing PC-Lint options), redirected outputs from PC-Lint, and a library definition file containing function declarations. These demonstration files are small but well thought-out; the first chapter of the manual does an excellent job of describing them. Another chapter of the manual introduces lint beginners to a philosophy (presumably that of the PC-Lint's author) regarding the use of the tool. It's called “Living with Lint (or Don't Kill the Messenger).”

The program's primary interface is

continued

PC-Lint 2.15

Type
PC-based lint programming tool

Company
Gimpel Software
3207 Hogarth Lane
Collegeville, PA 19426
(215) 584-4261

Format
One 360K-byte floppy disk

Language
C

Hardware Needed
IBM PC or compatible with 128K bytes of memory

Software Needed
MS-DOS 2.0 or higher

Documentation
96-page reference manual

Price
\$139

Inquiry 890.

the DOS command line. You can type the entire command line directly—LINT plus options (if any) plus the names of the C source files that PC-Lint reads—or you can put arguments and names of source files into a .LNT file and supply its name as an argument to PC-Lint. You can also store arguments in the environment variable LINT. If LINT is defined, PC-Lint inserts its value at the head of the list of arguments. This serves as a convenient way to specify a standard set of options.

The C source files that PC-Lint reads constitute a secondary interface. The program recognizes and acts on commands that you can embed inside comments; for example, the comment

```
/* lint -e711 */
```

disables error 711, the loss-of-precision warning.

You can send the program's output to a file by using the DOS redirection operator (>). When PC-Lint finishes, it returns an exit code corresponding to the number of errors it detected. Control programs written in DOS command language (.BAT files) can use the DOS

errorLevel facility to examine and act on the exit code.

The sample files that come with PC-Lint generate few errors. Real programs aren't usually so cooperative; they can cause PC-Lint to spew a torrent of syntax-error messages (alerting you to things like an unclosed comment), warnings (e.g., noting an unexpected use of a Boolean), and informational messages (e.g., indicating that a signed value will be shifted). The art to using lint lies in adjusting its verbosity to suppress extraneous messages while retaining those that warn of real trouble.

Have It Your Way

PC-Lint's many options will appeal to lint devotees, though the effort required to learn about all of them might be too much for occasional users. You specify these options by means of the primary interface (the DOS command line) or the secondary interface, (PC-Lint commands embedded in comments inside C source files).

You can fine-tune PC-Lint's verbosity by means of the e (error) options, which

continued

All the Power of A 25 MHz 386 At Half the Price of Compaq or IBM Omega 386/25 \$3295 386/16 \$2985

Complete High Quality 386/25/20/16 Systems

Omega 386/25/20/16 Motherboard
Hard/Floppy Controller 1:1 Interleave
I/O Card (Parallel, Serial, Game Ports)
Two 32 Bit, Four 16 Bit, & Two 8 Bit slots
Monochrome Graphics/Printer Adapter
1 Mb 80ns Memory (expandable up to 16 Mb)

* Ram Cache 386 soon available

Toshiba 40Mb 25ms Hard Drive
Teac 1.2Mb Floppy drive
101 Key Enhanced Keyboard
230 Watt Power Supply
AT Case Turbo/Leds, 5 Drive Slots
Packard Bell TTL Amber Monitor

* Tower Case available

All systems are custom assembled and burned in by OMI technical personnel and come with a 1 year warranty on parts & labor. All Prices Subject to Change without notice. IBM & Compaq are Trademarks of their respective Corporations.

Test Results	
386/25	286/20
Norton SI Ver 4.0	
28.2	27.3
Landmark Ver .99	
33.6	26.7
Power Meter Ver 1.20	
4.25 Mips	3.64 Mips

The Fastest 286 Available 286/20/16/12 System Specs

Omega 286/20/16/12 Mother Board
Award BIOS
Hard/Floppy Controller 1:1 Interleave
I/O Card (Parallel, Serial, Game Ports)
Six 16 Bit Slots & Two 8 Bit Slots
1 Mb Memory Installed

Teac 1.2Mb Floppy Drive
101 Key Enhanced Keyboard
230 Watt Power Supply
AT Case Turbo/Leds, 5 Drive Slots
Monochrome Graphics/Printer Adapter
Packard Bell TTL Amber Monitor

286/20 \$1895
286/16 \$1795
286/12 \$1495

Omega 88/10 XT Compatible

10MHz XT Motherboard (Phoenix BIOS)
Teac 360K Floppy Drive
Packard Bell TTL Amber Monitor
Floppy I/O Controller (2F,CLK,PP, SP, GP)
150 Watt Power Supply
AT Jr Case Turbo/Leds
Keytronics 101 Key Keyboard
Monochrome Graphics/Printer Adapter
8 Expansion Slots
640K Memory Installed **\$795.00**

Printers

Panasonic	
1080I	\$181
1091	\$222
1092	\$361
1592	\$400
1595	\$473

Modems

1200I	\$57
1200E	\$95
2400I	\$103
2400E	\$162

Hard Drives

Toshiba		
40Mb 25ms	\$543	
70Mb 25ms	\$895	
Micropolis		
72Mb 28ms	\$610	
Miniscribe		
8425 20Mb 65ms	\$281	
8438 20Mb 65ms	\$287	
3053 40Mb 25ms	\$618	
3085 72Mb 28ms	\$720	
6085 72Mb 28ms	\$966	
6128 100Mb 28ms	\$850	

Floppy Drives

Teac		
720k 3.5"	\$115	
1.44M 3.5"	\$125	
360k 5.25"	\$89	
1.2M 5.25"	\$104	

SMS Omti

5527 XT RLL	\$83
8240 AT MFM	\$144
510 SCSI	\$65
512 SCSI	\$80

Monitors

Samsung White Mono	\$100
Packard Bell Mono	\$80
Thomson Mono	\$110
Princeton MAX12	\$158
Thomson CGA	\$240
Mitsubishi CGA	\$269
Packard Bell EGA	\$375
Samsung EGA	\$386
Mitsubishi EGA	\$408
Mitsubishi Multi	\$528
Technica Multi	\$443
Tatung VGA	\$582

Other product lines offered:

Video Seven
Keytronics
Northgate
Archive
Novell
AutoDesk
Epson
Western Digital
DTC
Sharp
And Many More!



Call For More Information Including Complete Product Catalogue
OMEGA MICROSYSTEMS INC.
1029 Franklin Road Suite 4-C Marietta, Georgia 30067

Toll Free (800) 346-6527
In Georgia (404) 429-8862
Fax: (404) 953-6286

Hours: 9am-8pm EST
Monday thru Friday

We Will Gladly Answer Any Customer's Technical Questions!



Our Printer Sharing Unit Does Networking!

An Integrated Solution

Take our **Master Switch™**, a sophisticated sharing device, combine it with **MasterNet™** networking software for PCs, and you've got an integrated solution for printer and plotter sharing, file transfer, electronic mail, and a lot more. Of course you can also share modems, minis, and mainframes or access the network remotely. Installation and operation is very simple.

Versatile

Or you can use the Master Switch to link any computer or peripheral with a serial or parallel interface. The switch accepts over 20 commands for controlling the flow of data. It may be operated automatically, by command, or with interactive menus. Its buffer is expandable to one megabyte and holds up to 64 simultaneous jobs. The

MasterLink™ utility diskette for PCs comes with every unit and unleashes the power of the switch with its memory-resident access to the commands and menus.

Other Products

We have a full line of connectivity solutions. If you just want printer sharing, we've got

it. We also have automatic switches, code-activated switches, buffers, converters, cables, protocol converters, multiplexers, line drivers, and other products.

Commitment to Excellence

At Rose Electronics, we're not satisfied until you're satisfied. That's why we have thousands of customers around the world including large, medium, and small businesses, factories, stores, educational institutions, and Federal, state, and local governments. We back our products with full technical support, a one-year warranty, and a thirty-day money-back guarantee.



**ROSE
ELECTRONICS**

**Call now for literature or
more information.
(800) 333-9343**

Give a Rose to your computer

enable or disable individual messages or entire classes of messages. For example, `-e501` forces PC-Lint to ignore error 501; `-e7??` turns off all 700-series (informational) messages. When you've written a piece of code that you know PC-Lint won't like, you can build a detour around it like this:

```
float f;
int i;

...

/* lint -e711 disable loss-of-precision warning */

i = (int)f;

/* lint +e711 enable loss-of-precision warning */
```

This prevents PC-Lint from complaining about an intentional coercion of a float to an int, while retaining protection against unintentional coercions elsewhere in the program. It's a nifty feature, although if you use it often, you'll find yourself typing a lot of extra comments as you lint your way through program development.

You can also disable three general classes of error related to function arguments—arguments of unlike type (one signed, one unsigned), arguments of unlike type (yet the same size), and pointer arguments having different indirect types. These error classes are a bit obscure for my taste, and the options (e.g., `-eau`, `-eas`, and `-ep`) aren't easy to remember, despite the manual's attempt to present mnemonic aids.

Size options simplify life if you port code between machines that have different scalar sizes. The `-s12` option, for example, specifies that integers are in 2-byte quantities.

The `f` (flag) options enable or disable global condition flags. For example, `+fnc` permits code to have nested comments, and `-fum` disallows duplicate member names in different structures.

The height options govern the style of PC-Lint's output and are good candidates for inclusion in the LINT environment variable. I preferred compact two-line error messages to the default four-line style, so I specified `-h$2` (the dollar sign appears in the source line at the location of the error).

Miscellaneous options enable you to specify preprocessor variables (as with the Microsoft C Compiler's `/D` switch), restrict the acceptable keywords to those included in the current ANSI standard,

Listing 1: The file `test.c` contains subtle and not-so-subtle bugs.

```
1 #include <stdio.h>
2
3 #define ZIP 5
4 #define ZAP -1
5
6 main() {
7   int h=50;
8   int i=10;
9   int *j = &i;
10  int k,m,n,q,r=20;
11  static char (*hah)[20];
12  char **p;
13
14  printf("Beginning of program\n");
15
16  n = ZIP-ZAP;
17  q = product( 3.0 );
18  printf("n = %d; q = %d; r = %d\n",n,q);
19
20  k = h/*j;
21
22  for (m=-3;m<k;printf("The value of m is %d\n",m++))
23    /* don't do anything */ ;
24
25  if ( r = 5 )
26    printf("The value of r is 5.\n");
27  else
28    if ( r = 20 )
29      printf("This'll never get printed.\n");
30
31  printf("End of program\n");
32
33 }
34
35
36 double product( x, y )
37 int x,y;
38 {
39  return ( x * y );
40 }
```

specify a particular memory model, and force PC-Lint to return a zero exit code.

C Compilers and C Versions

In theory, C compilers are functionally identical. In practice they aren't, because they use different libraries and sets of preprocessor variables. PC-Lint helps smooth out the differences. It provides a selection of library definition files for more than a dozen C compilers. In a library definition file, declarations like

```
void printf(char *,...);
```

tell PC-Lint that functions so declared are defined in a library. If you work with a single C compiler, the easiest thing to do is erase all the library definition files except for the one you need. If you work with several compilers, you can use the `c` (compiler) option to tell PC-Lint to select the appropriate one.

C itself has evolved considerably since

Kernighan and Ritchie published *The C Programming Language* in 1978. (C programmers refer to this book, and to the language it describes, as K&R.) Although ANSI hasn't yet released the new standard for C, many C products—including PC-Lint—have incorporated some generally accepted non-K&R extensions to C. PC-Lint supports many of these extensions, including the void type, function prototypes, enumerated data types, and the `##` token-pasting operator.

On the Firing Line

In search of linty source code, I looked back through several years' worth of notes from real C programming projects. From the pages marked "Bug of the Week" and "Aaaarrgghhh of the Month," I pieced together a nonsense source file (`test.c`) containing some classic quirks (see listing 1).

First, I ran the file through the Micro-

continued



WHEN THEIR CUSTOMERS DEMANDED UNIX SYSTEM V SOLUTIONS, THESE INDUSTRY LEADERS CAME TO SCO

Standards are made, not born.

The leading UNIX® System on three generations of PCs, SCO™ XENIX® System V has revolutionized the way people look at both the UNIX System and PCs by revealing the amazing hidden potential of these standard hardware platforms.

In the process, SCO XENIX has become a true standard in UNIX System V software.

And like a true standard, SCO XENIX has opened up entire new markets of opportunity that have never before existed for micro-processor-based computers.

Teamed with the latest generation of 80386-based machines, SCO XENIX 386 allows systems created from the widest range of hardware choices to surpass the multiuser, multitasking performance of minis or even mainframes—at a fraction of the cost.

SCO XENIX can be found running thousands of XENIX- and UNIX System-based vertical applications on powerful business systems supporting 16, 32, or even more users. And on graphics workstations running advanced engineering and scientific applications.



And, of course, on personal computers, running multiple DOS applications concurrently, or networking XENIX and DOS systems together.

Today, more and more end users are demanding the power that only UNIX System V software can bring to their standard hardware platforms.

And when leading developers, resellers, and computer manufacturers who serve these users want to make sure they're working with a partner who's the UNIX System software leader—for now, and long into the future of UNIX System standards—they come to SCO.

They know that SCO will provide them with the most comprehensive environment for UNIX System applications, technical and marketing support, training, and documentation in existence.

And they know they can trust SCO UNIX System software to be the most complete and reliable anywhere in the world, because it comes from the most complete and reliable UNIX System software company in the world.

The UNIX System software leader—SCO.



The UNIX System Software Leader Worldwide

(800) 626-UNIX (626-8649) • (408) 425-7222 • FAX: (408) 458-4227 • TWX: 910-598-4510 SCO SACZ • E-MAIL: ...!uunet!sco!info info@sco.COM

UNIX is a registered trademark of AT&T. SCO and the SCO logo are trademarks of The Santa Cruz Operation, Inc. XENIX is a registered trademark of Microsoft Corporation.
© 1988 The Santa Cruz Operation, Inc., 400 Encinal Street, P.O. Box 1900, Santa Cruz, CA 95061 USA The Santa Cruz Operation, Ltd., Croxley Centre, Hatters Lane, Watford WD1 8TN, United Kingdom, +44 (0)923 816644, FAX: +44 (0)923 817781, TELEX: 917372 scotcom g

Never buy another ribbon! with MacInker™

over 100,000 sold

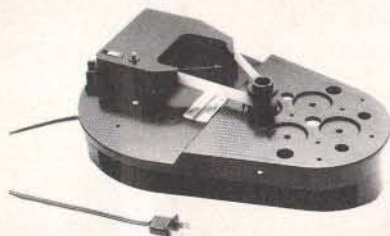
Universal Cartridge MacInker **\$68.50**Imagewriter or Epson MacInker **\$42.00**

Eliminate expensive ribbon replacement with the famous MacInker. The Universal Cartridge MacInker (\$68.50) will re-ink most cartridges with the appropriate adaptor. The Universal Spool MacInker will re-ink all spools. Operation is very simple & automatic. Our extra dark, lubricated ink yields better than new printout quality and its cooling effect extends print-head life. New ink dispenser ensures precise ink metering. Average number of re-inkings/cartridge is 60-100 at an average cost of 5cents/re-inking. We also have dedicated MacInkers for special cartridges. All MacInkers, with appropriate Multicolor Adaptor can re-ink multicolor cartridges (2 or 4 colors). Or use your MacInker to re-ink in 10 different colors: red, green, blue, yellow, purple, brown, orange, gold and silver. Our Customers range from individuals to Fortune 500 Corporations. In 1982 we pioneered re-inking technology and are dedicated to its development. We have a complete range of accessories, heat-transfer re-inking adaptors, special inks and cartridges.

New

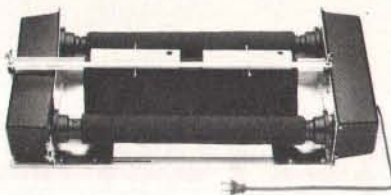
Band Printer MacInker **\$299.00**

Universal Cartridge MacInker	68.50
Multicolor Adaptor (specify printer)	40.00
Imagewriter I/II MacInker mod 234 IM	42.00
Epson MacInker mod 271EP	42.00
Universal Spool MacInker	68.50
Heat Transfer Adaptor	40.00
Extra Ink bottle	3.00
pint	18.50

Call for free catalog

Special Offer

Free mousepad for any order >\$60.00. Free Key-beeper & flashlight combined for orders >\$100.00.

Buy the Universal Cartridge & the Universal Spool at the same time and get the second unit for \$50.00

All MacInkers delivered with bottle of ink, ink meter, reservoir, reservoir cover. Black, uninked, colored, special cartridges available. Best ribbon quality at lowest costs.

Multiuser Printer Buffers

Let us configure the most economic & efficient buffer set-up when using two printers with one computer or two computers and two printers. We have the most complete range of buffers, converters, switches, cables & custom cables. Award winning Proteus switches manually or by software between 2 printers. Memory is automatically partitioned & both printers can print simultaneously.

UG-411, 1 comp. / 1 printer	64k	160.00
	256k	270.00
UG-402 2 comp. / 2 printers	64k	199.00
	256k	330.00
PROTEUS, 1 comp. / 2 printers	64k	199.00
	256k	330.00
UG-403 4 comp. / 2 printers	256k	399.00
UG-408 4 comp. / 4 printers	512k	500.00
UG-412 Serial buffer card 1 MEG		500.00
CBL-715 Univ. ser-par-ser converter		159.00
CBL-705 Ser-par converter		99.00
Autoscanning switches (4 to 1)		169.00



UG-402



Proteus

Satisfaction or 30 day refund on all products - Immediate shipment - Major credit cards

Computer Friends, Inc. Order Toll Free 1-800-547-3303

14250 NW Science Park Dr.
Portland OR 97229

in Oregon (503)626-2291
fax (503)643-5679 telex 4949559 CF

soft C 5.0 Compiler with the command `c1 /c /DLINT_ARGS /W0 test.c`, which compiles `test.c` at warning level 0 (the most permissive). I repeated the test at warning levels 1, 2, and 3 (the most stringent). Then I submitted the same file to PC-Lint.

The only problem that the Microsoft compiler caught at all warning levels was the redefinition of `product()`. PC-Lint caught it, too, and it also noted the conflict between the number of arguments in the definition (two) and in the function call (one). At level 3, the Microsoft compiler notes that the symbols `p`, `hah`, and `m` are not referenced, and, sure enough, that turned out to be true. PC-Lint notes the same thing; it also shows that `j` isn't referenced and that both `r` and `k` aren't accessed. The problem is the statement `k = h/*j`; at line 20. The `/*` characters parse as the beginning of a comment, so `k` gets the value of `h`, and the compiler ignores everything until it sees the terminating `*/` in the comment on line 23.

Unlike the Microsoft compiler, PC-Lint found the mismatch between `format` string and arguments in the `printf()` statement at line 18 and caught the classic misuse of the assignment operator (`=`) for the equality operator (`==`) at line 25. Neither the compiler nor PC-Lint found the bug in line 16. After the preprocessor replaces `ZIP` with `5` and `ZAP` with `-1`, the statement becomes `n = 5-1`; which is clearly illegal.

A Good Tool

PC-Lint should appeal to a variety of users. It can help novice C programmers with the tricky aspects of the language. Experienced programmers—even those intimately familiar with C compilers that provide lint-like capabilities—can still benefit from its stringent analysis of source code. In a sense, you get out of PC-Lint what you put into it.

Typically, I just let the program run and redirected its output to a file for examination. I learned to ignore certain types of complaints; in time, I'm sure I'd get around to using the appropriate options to suppress them. PC-Lint does its job well and belongs in the C programmer's toolbox.

Editor's note: *Listing 1* is available in a variety of formats. See page 3 for details. ■

Alex Lane is a knowledge engineer for Technology Applications, Inc., of Jacksonville, Florida. He can be reached on BIX as "a.lane."

95% of the Top U.S. Companies Solve Their Complex Numeric Problems with APL ...Shouldn't You?

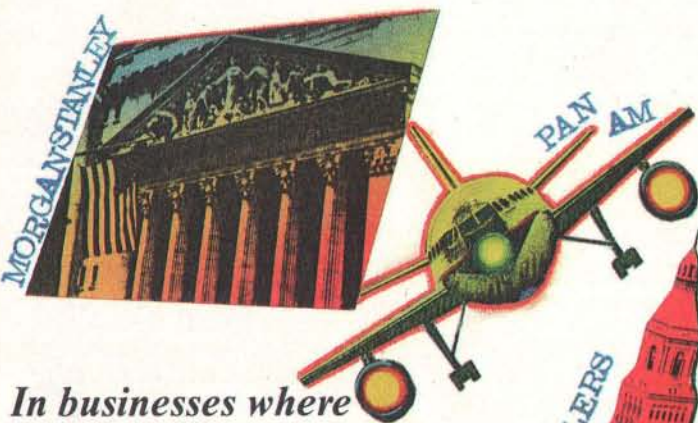

In businesses where complex numeric problems are a daily challenge, professionals from all walks of life rely on APL★PLUS®.

Thousands of professionals in a wide range of fields—investment research, insurance, corporate finance, engineering, and science—find APL★PLUS the perfect software for complex problem solving. That's because its natural mathematical orientation and concise code provide the ideal environment for model building, array handling, system prototyping, and matrix manipulation.

Why not give yourself the analytical edge, for only \$695*. Call 800-592-0050 and we'll show you how to put APL★PLUS to work in your specific application.

Many of our technical professionals are fluent in the use of APL. For us, APL's combination of power, and expressiveness makes it the perfect tool for analysis and visualization of experimental data as well as scientific and engineering computations.

Frederick J. Krambeck
Manager, Process Development
Mobil Research and Development Corporation

STSC
STSC, Inc.
2115 East Jefferson Street
Rockville, Maryland 20852
800-592-0050
301-984-5123 in Maryland or Canada
Telex 898085

APL is indispensable in developing mathematical models for pricing financial securities such as options, futures, and bonds. Complex mathematical algorithms are programmed quickly and concisely. And, empirical research is facilitated by APL's unmatched capabilities in manipulating and analyzing arrays of data.

Mark Schroder
Option Research Specialist
Prudential Bache



When you need to consider three classes of service, numerous fare types, and multiple connections, fare pricing analysis without APL is a Herculean task. APL's ability to manipulate tables of data with a single command enables us to explore a wider range of scenarios as fast as we can think of them.

Mike Fisher
Manager, Systems Development
Pan American World Airways



Each quarter we consolidate and analyze historical data, current data, and forecasts from over 800 entities within GE and then quickly compile it into a comprehensive series of reports. With APL we get it done in a third of the time it would take us using other methods.

Eric Baelen
Manager, Business Systems Development
General Electric Company



The APL★PLUS System is available for the mainframe, IBM PC and compatibles, Macintosh, and machines running UNIX and VAX/VMS. The APL★PLUS System may be purchased through dealers and distributors worldwide.

APL★PLUS is a registered trademark of STSC, Inc. UNIX, Macintosh, and IBM are registered trademarks of AT&T Bell Laboratories, Apple Computer, and International Business Machines Corporation, respectively.

Top companies according to the April 17, 1987 issue of *Business Week*.
*U.S. suggested retail for DOS version. International prices slightly higher.

**Now! APL★PLUS II
For The
80386.**

The shortest distance between two points. Pro-C.TM

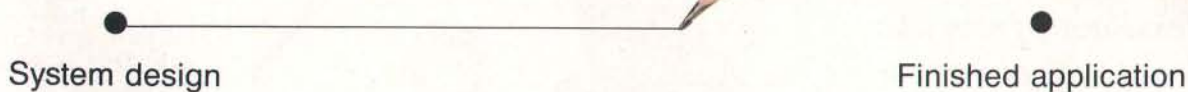

The C source code applications generator.

At last, the distance between system design and final application is shorter than ever before. Pro-C maximizes your productivity by creating commercial applications in C source code.

Pro-C quickly generates well-structured, fully-commented C code the way you would write it. This allows you to concentrate on systems design instead of wasting time repeatedly rewriting code. Plus, Pro-C can also be used as a powerful prototyping tool that readily converts system design into clean, professional code.

Learning to use Pro-C is simple: Menus guide you through every step, and context-sensitive help is always available. Pro-C quickly generates source code for screen programs, reports, menus, and multi-file updates, as well as concise system documentation and context-sensitive help.

PC Tech Journal applauded the power of Pro-C in a recent review: "The generated C code is excellent, including many comments and the type of functional organization that a good programmer would choose. . . Pro-C excels at what it was designed for."

Pro-C is the only source code generator that runs under the MS-DOS[®], QNX[™], XENIX[™] and UNIX[™] operating systems. Unlike most 4GL's, Pro-C doesn't require a run time environment—increasing performance without royalty fees.

For added flexibility, a separate product, Pro-C Workbench[™], provides the C source code for over 60 Pro-C library routines that can be modified to your requirements.

Pro-C code is optimized for a variety of compilers, including Microsoft[™] C V5.0 and later, Quick C V1.0, Turbo C[®] V1.0 and later, Lattice[®] C V3.2, and Zortech[™] V2.05.

Pro-C: Beyond programmer productivity tools
Eliminate repetitive programming. Streamline application development. Achieve maximum productivity. Order Pro-C today. Call (800) 265-2682. For information on corporate purchases, call Chris Finnegan at (519) 745-2700.



VESTRONIX

ALLEN SQUARE 180 KING STREET SOUTH SUITE 230
WATERLOO, ONTARIO, CANADA N2J 1P8 (519) 745-2700

ADDITIONAL LOCATIONS: UNITED KINGDOM 01-790-2424
GERMANY 6155-6008-0 JAPAN 03-407-8561

MS-DOS & Microsoft are registered trademarks of Microsoft Corp. UNIX is a trademark of AT&T Bell Laboratories. Turbo C is a registered trademark of Borland International. QNX is a trademark of Quantum Software Systems Ltd. Lattice is a registered trademark of Lattice, Inc. Zortech is a trademark of Zortech, Inc.

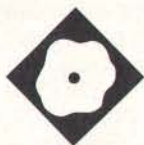

SpinRite



Recover bad sectors
and change the interleave
ratio on your hard disk

Richard Grehan

SpinRite is one of those products that generate immediate suspicion. The claim that a piece of software can repair what many have been led to believe is entirely a hardware problem—bad sectors on your hard disk drive—does prompt people to inch away. Tack on the additional claim that the program can perform a low-level format on your hard disk drive and leave your data intact, and inching away becomes noisy backpedaling. I'll admit I was skeptical; when asked to review SpinRite, the first thing I had to find was a sacrificial hard disk drive.

SpinRite (\$59) from Gibson Research is a powerful, low-level diagnostic and maintenance program for hard disks in IBM PCs and compatibles. I say "low-level" because SpinRite does not concern itself with file structure on the disk; it works with sectors and tracks of data, not directories and files. SpinRite also performs diagnostics on other aspects of your system: It tests system RAM, veri-

fies that your controller is working properly, and checks the disk controller's RAM.

SpinRite also determines your hard disk's track-to-track (adjacent tracks) and average seek times. I compared SpinRite's results with the results from the Core test. Both tests showed that the Everex drive's average seek time was about 23 milliseconds, but SpinRite calculated the track-to-track seek time as 3.73 ms while the Core test found it to be 5.49 ms. But beyond diagnostics, SpinRite can actually recover sectors marked as bad by the hard disk drive controller; and it can modify the interleave pattern on your hard disk drive to guarantee the maximum possible throughput.

Taking It for a Spin

I ran SpinRite on an Everex 386/20's internal 30-megabyte hard disk drive, and it informed me that I had 51,200 bytes' worth of bad sectors. I already knew this, because I had just executed FORMAT on the drive, which reports how many bytes' worth of bad data the drive is infected with. What I wasn't ready for was that SpinRite was raring to go fix the data; all I had to do was turn it loose on the hard disk drive to do a low-level reformat with the program's extremely thorough pattern testing activated.

SpinRite's low-level reformat is unique in its own right, since it does its job while leaving the hard disk's data intact. I am not suggesting that you try it without performing a backup; the SpinRite documentation urges you to back up the contents of the hard disk prior to reformatting as a safeguard. But if the low-level format goes well—and it usually does—you don't have to spend the rest of the day reloading your files. However, SpinRite's real claim to fame is its ability to recover bad sectors, and even though the pattern testing took over 2 hours, I got my 51,200 bytes back. I wrote files on the hard disk and everything—I even

continued

SpinRite 1.02

Type

Hard disk utility

Company

Gibson Research Corp.
22991 La Cadena
Laguna Hills, CA 92653
(714) 830-2200

Format

One 5¼-inch floppy disk

Language

Machine

Hardware Needed

IBM PC or compatible with a hard disk drive

Documentation

40-page user's manual

Price

\$59

Inquiry 888.

ran the Norton Disk Test utility a half-dozen times just to make sure all was OK.

SpinRite also boasted that it could determine the proper interleave for a given drive and controller configuration and change the interleave—ostensibly to its optimum—leaving the hard disk's data intact. For the Everex I mentioned above, the interleave was set to 1-to-1, and SpinRite showed that the Everex couldn't do any better than that. So I decided to set the Everex to a 2-to-1 interleave to determine how much worse its performance would be. This meant that I had to send SpinRite off for another round of its pattern testing. Here's where more of SpinRite's user-friendliness showed through. The reformat takes a long time. I started it late in the afternoon, and it happened that power would be shut off so that BYTE could install its new uninterruptible power supply that evening. Could I interrupt SpinRite's low-level formatting and restart it the next day, where I left off? You bet. The next morning, when I booted the machine and started SpinRite, it asked if I wanted to resume the current operation.

The program finished the interleave change in about an hour.

With a 2-to-1 interleave, SpinRite reported that I could expect a maximum throughput of 261,120 bytes per second. For a 1-to-1 interleave, SpinRite promised a maximum throughput of 522,240 bytes per second. Table 1 shows the results of the BYTE low-level disk benchmarks for both interleave patterns. As you can see, a 1-to-1 interleave provided an overall performance improvement, though not as much as I would have expected. The DOS Seek benchmark gains the most; the File I/O test showed little gains, if any (I would have expected little gain from this benchmark anyway, since it performs lots of random reads and writes); and the 1-megabyte File Read and Write benchmarks are split on gain and loss.

The final figures are most surprising; optimizing interleave should improve throughput for those operations that read and write logically contiguous sectors (assuming that logically contiguous sectors are also physically contiguous on a track)—which is exactly what the 1-megabyte File benchmarks were de-

APPLE AND OOPS. A PEACH OF A PAIR.

Romeo and Juliette. Lucy and Desi. Fred and Wilma. Sometimes couples just seem made for each other. And now when you put Smalltalk/V and your Macintosh together you've got a marriage made in heaven.

Object Oriented Programming was made for Macintosh. Smalltalk/V Mac lets you develop Mac applications easier than ever before using the prototype style that Smalltalk is famous for. You also get push-button debugging; multi-processing; complete Toolbox access; MultiFinder compatibility; a rich class library; and a bushel basket of Smalltalk source code. All in our high-performance 32-bit architecture.

Interestingly enough, Macintosh was made for OOPS. Much of the unique hardware and interface design in Mac development

came directly from Smalltalk research. This is no casual affair.

Love, it is written, is not selfish or arrogant. So when you become passionately involved with Smalltalk/V Mac, your work is fully compatible with Smalltalk/V on IBM PCs (and clones) operating with DOS, OS/2 and Presentation Manager.

The new Smalltalk/V Mac sells for a peachy \$199.95 and comes with our no-questions-asked 60 day money-back guarantee.

If your dealer isn't into OOPS, order toll free, 1-800-922-8255. Or write to; Digitalk, Inc., 9841 Airport Blvd., Los Angeles, CA 90045. Smalltalk/V and Apple. Now

there's an appealing couple.

Smalltalk/V Mac

Table 1: As expected, a 1-to-1 interleave provides an overall performance improvement compared to a 2-to-1 interleave. However, the performance gains are somewhat overshadowed by the seeks to and from the file access table.

Benchmark	1-to-1 Interleave	2-to-1 Interleave
DOS Seek		
1-sector	5.35	10.83
32-sector	38.58	41.49
File I/O		
Seek	.15	.05
Read	1.41	1.58
Write	1.14	1.24
1-megabyte File		
Write	6.26	6.00
Read	7.03	7.21

Notes: All times are in seconds, except the File I/O read and write times, which are in seconds per 64K bytes. The seek time for File I/O is approaching the resolution of the timing routine. For intervals that small, the signal-to-noise ratio is getting dangerously low.

signed to do. An engineer from Gibson Research pointed out that I should be careful about what I was testing—what I was testing *exactly*. Simply reading a file involves seeks to and from the system's file access table, and the time required

for those seeks might overshadow the sector I/O time. In all fairness, SpinRite did report the maximum *possible* throughput for each interleave factor; how the operating system performs its hard disk I/O could reduce any perfor-

mance differences between different interleave factors.

A Must-Use Utility

All I can say about the Gibson Research people is that they did their homework. The user interface is well thought-out and easy to use; all interaction is via an easy-to-navigate window system. The package comes with a hard disk and a 40-page user's manual that is more interesting for its historical content (how the authors of the package made all their discoveries about hard disks) than any other information. The program is so well put together, I found I seldom referred to the manual, anyway.

SpinRite is no 14-disk grand-slam C compiler, but you shouldn't underestimate its usefulness. If you have a PC with a hard disk drive that you spend most of your day relating to, and your heart sinks every time you see the drive's bad sector list, SpinRite is what the word "must" was invented for. ■

Richard Grehan is a BYTE senior technical editor at large. He can be reached on BIX as "rick_g."

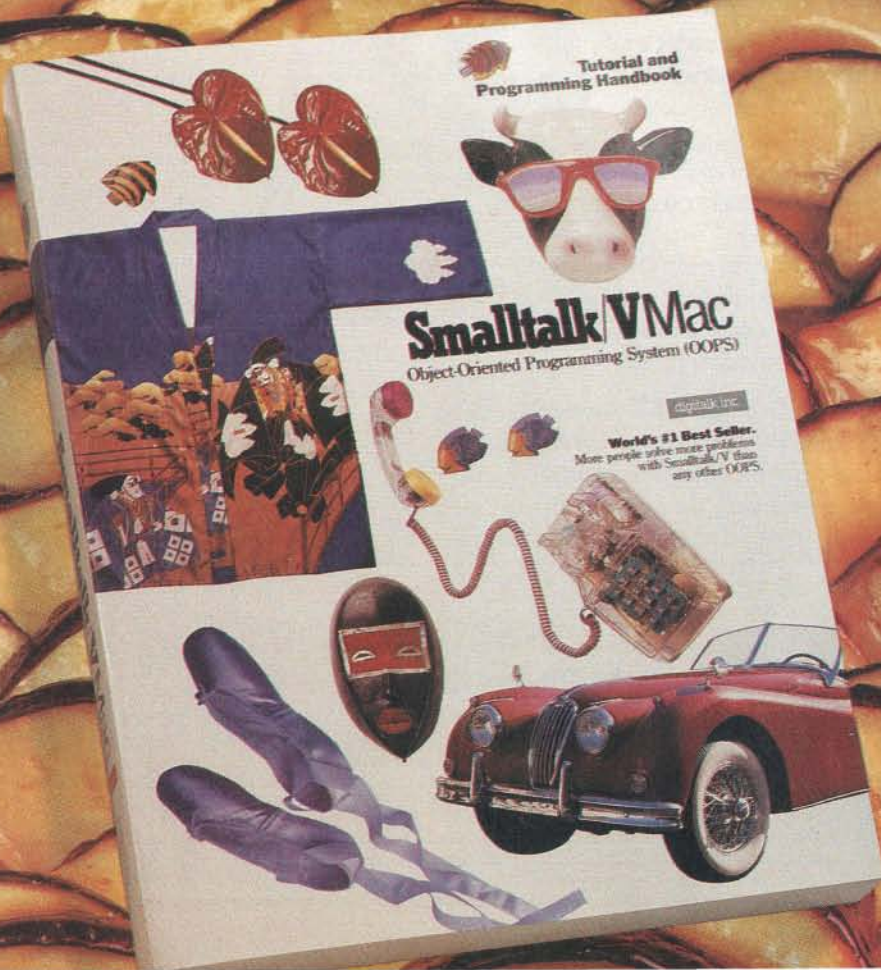

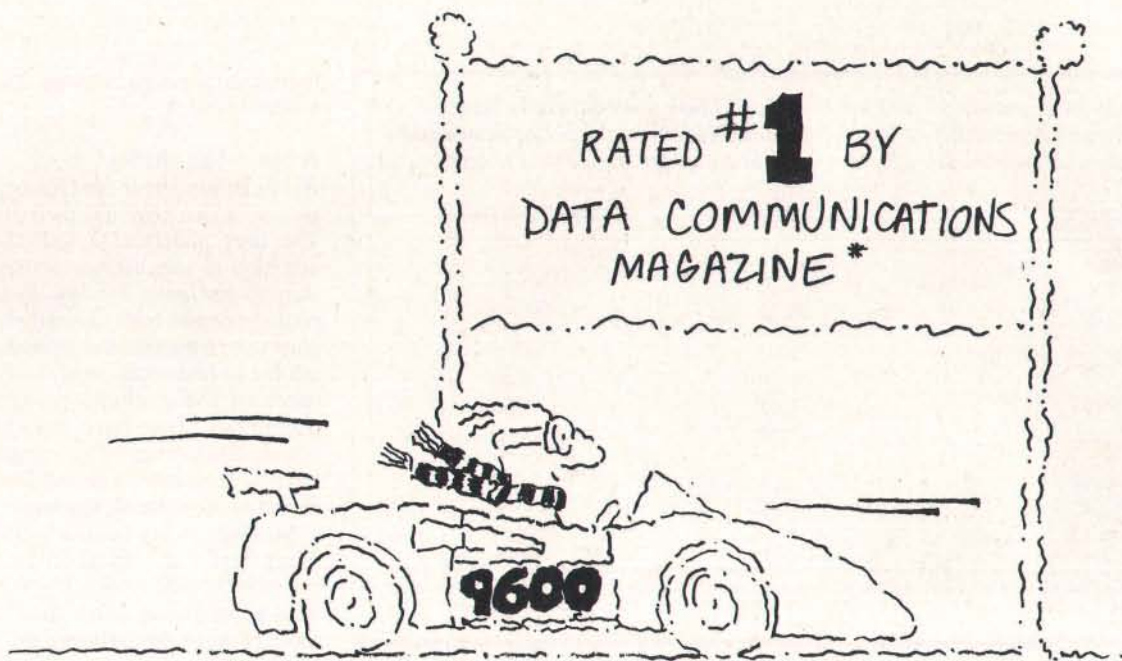

At 17,400 bps and under \$1,000... The new champion is Courier HST.™

The race belongs to the swift and that's why USRobotics' Courier HST is "the champion".

In race after race among high speed modems, the Courier HST outperforms the high-priced competition.

The writers at *Data Communications* and the independent testing laboratory, Telequality Associates, concluded in their head-to-head modem test:

"The USRobotics Courier HST modem, the least expensive of all the modems tested, outperformed all the pseudo-duplex modems on the line simulation tests..."

And *PC Magazine* calls the Courier HST, "the top price-performance ratio at 9,600 bps."

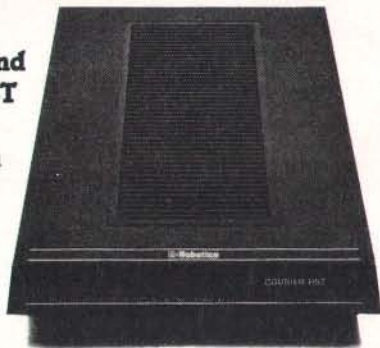

USRobotics:

The secret to our success?

Partly, it's our innovative V.32 asymmetrical data pump with MNP™ Level 5 data compression delivering 17,400 bps... *saving you money on phone line charges.*

Partly, it's our unique automatic fall-back/fall-forward which assures you the fastest speed possible.

But there's even more to being "the champion" than that.

Mostly, it's the security you get from knowing you are buying the #1 rated modem.

If you are considering trading in your current modem for a high speed modem, don't get left in the dust.

Get the new champion—**Courier HST.**

Call 1-800-DIAL-USR

In Illinois (312) 982-5001

U-Robotics®

The Intelligent Choice in Data Communications
8100 North McCormick Boulevard, Skokie, Illinois 60076.

*Rated first by *Data Communications* under frequently encountered line conditions. *Data Communications* May 1988.

USRobotics, Courier and HST are trademarks of U.S. Robotics, Inc. Other computer and software names identified by ® or ™ are tradenames and/or trademarks of their respective manufacturers. For sales in the United Kingdom, please call Maricom, Ltd., Ipswich, England. Telephone: 0473 233988.



Features vs. Speed

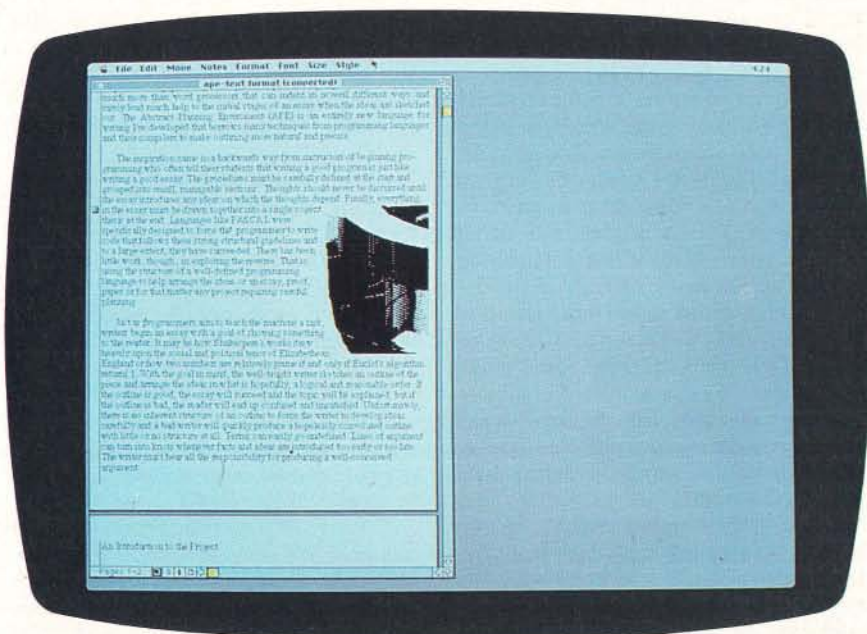

FullWrite takes the feature-rich approach to word processing

Diana Gabaldon

Calling FullWrite Professional 1.0 "full-featured" is an understatement. It's a word processor for the Macintosh with all the attendant ruffles and flourishes, but it also has many capabilities commonly found only in desktop publishing packages. For example, it can wrap text around graphics, it mingles graphics, notes, outlines, and text, and it even has a MacDraw-like facility that lets you create simple drawings without leaving the pro-

gram. For all its functionality, however, FullWrite also has some significant performance disadvantages that you may find limiting.

FullWrite (\$395) is produced by Ashton-Tate, and it runs on any Mac Plus, SE, or II with at least 1 megabyte of memory, one 800K-byte floppy disk drive, and a hard disk drive.

FullWrite lets you choose from four displays: the icon bar, the outline bar, the change bar, and WYSIWYG. The icon bar displays symbols indicating the position of embedded notes, rulers, sidebars, and other formatting in a vertical bar to the left of your text. The 15 symbols aren't all intuitive, however, so it takes some time to distinguish between them. The outline display lets you view your document in outline format and can collapse the outline to display only headers or only body. The change bar flags all changes that you've made to a document since the last session or the last save.

The program includes an undo key,

spelling checking with a 100,000-word dictionary and optional in-context checking capability, and a 15,000-root-word (220,000-synonym) thesaurus. Formatting functions include automatic hyphenation (with soft hyphens available), adjustable-height headers and footers, and automatic table of contents and hierarchical index generation.

FullWrite also has features that you don't see in many other word processors. For example, FullWrite lets you break a document file up into chapters and keeps only the chapter you're currently editing in memory. And while Microsoft Word and other word processors have outliners, FullWrite's outliner not only expands, collapses, and adjusts, but it also can outline over multiple chapters of a document. Most word processors let you footnote a document, but FullWrite gives you footnotes (floating or fixed), endnotes, posted notes (the electronic equivalent of 3M's yellow Post-it Notes), content notes, index entry notes, and bibliography entry notes, and it lets you browse through them from any point in a document.

The search-and-replace function is also quite sophisticated. In addition to text string and wild-card searches, you can search for text with specific style attributes and even for invisible characters such as tabs, spaces, and carriage returns. In contrast, Word lets you search for text and some attributes, but not for invisible characters.

In some cases, the program also anticipates things you want to do and makes automatic adjustments. For example, whenever you enter specifications for an option in the layout box, FullWrite automatically adjusts related options. If you change the number of columns, the column width changes automatically.

And, as with Word, you can express things such as margins in terms of multiple units of measure: inches, centimeters, picas, and points. But FullWrite

continued

FullWrite Professional 1.0

Type

Word processor

Company

Ashton-Tate
20101 Hamilton Ave.
Torrance, CA 90502
(213) 329-8000

Format

Three 3 1/2-inch 800K-byte floppy disks

Language

Pascal

Hardware Needed

Mac Plus, SE, or II with a minimum of 1 megabyte of memory (2 megabytes recommended), one 800K-byte floppy disk drive, and a hard disk drive

Software Needed

System 4.1 or higher, Finder 5.5 or MultiFinder 1.0, Font/DA Mover 3.6, and LaserWriter Driver 5.0

Documentation

250-page spiral-bound Learning Guide
300-page Professional Reference Guide
Keyboard Shortcuts card

Price

\$395

Inquiry 891.

also adds pixels to the list.

In addition, FullWrite lets you zoom in to display a full-page or even a two-page layout on a single screen. And if the available fonts and type sizes are insufficient for your needs, FullWrite lets you specify a nonstandard-size font and kern existing fonts (two characters at a time) to improve spacing.

FullWrite's MacDraw-like facility lets you create simple line drawings, and you can paste irregularly shaped images from the Clipboard directly into your document and wrap text around them. The latter is a fairly complicated process, however, and involves putting the graphic into a sidebar to position it.

Under the Get Info selection, summary information is available for the document you're currently editing. Data includes the author, the revision date, and the time and number of keystrokes you've made. Word has a similar capability, but FullWrite also gives you character, word, line, paragraph, and page counts. The summary screen also in-

cludes a readability index that indicates the complexity of writing on a scale of 1 to 13, with the numbers 1 through 12 corresponding to grade levels and the number 13 indicating college level.

Juggling Documents

FullWrite lets you open and alternate between multiple windows containing chapters or documents. The maximum number of windows you can open is limited only by available system memory. On a 1-megabyte system, you might find using windows to be impractical because you run out of memory quickly. There are also multiple save and print functions that let you check off a list of documents for saving or printing.

For document management, FullWrite uses a virtual memory system that breaks long documents into smaller chapters. FullWrite keeps the current chapter text and formatting in memory. The rest of the file resides in a virtual memory file on disk. When a chapter becomes too large for RAM, FullWrite warns you to break it into more chapters.

Technically, a chapter of 30 pages is about as much as a machine with 1 megabyte of memory can handle. Practically, however, sidebars, graphics, indexes, and other elements quickly eat up available memory and whittle a chapter down to just a few pages.

An Auto-Save option saves the current chapter at user-selected intervals. This feature can be more of an annoyance than a convenience, as chapter saves can interrupt your work for several seconds, depending on the extent of the changes you've made since the last save. You can also set an auto-backup function to automatically create an archival copy of the entire document, but this process hangs up your system for about 5 seconds.

FullWrite can read a variety of document formats in addition to its own. These include Word 1.05, 3.01, and 3.02; MacWrite 2.2, 4.5, and 5.0; MultiMate 3.31; MultiMate Advantage; MultiMate Advantage II 1.0; and ASCII text files. However, FullWrite can write only to FullWrite, MacWrite 4.5, and ASCII text formats.

Slow Performance

The BYTE editors and I ran FullWrite on several machines, including a Mac SE with 1 megabyte of RAM and an 800K-byte floppy disk drive that I had networked to an 80-megabyte file server; a Mac SE with 4 megabytes of memory, one 800K-byte floppy disk drive, and a 20-megabyte hard disk drive; a Mac II with 5 megabytes of RAM, a 68851

paged-memory-management-unit chip, a video board with a 256K-byte color upgrade, an 80-megabyte hard disk drive, and one 800K-byte floppy disk drive; and a Mac Plus with 1 megabyte of RAM, an 800K-byte floppy disk drive, and a 20-megabyte Super Mac Data-Frame small-computer-system-interface hard disk drive.

FullWrite's minimum requirement is 1 megabyte of memory, but you'll need more than that to make full use of the program. FullWrite was slow to respond on the Plus, and I quickly ran out of memory on the 1-megabyte Plus and SE when creating even small documents. My machine returned a Document is too big message after creating a five-page chapter with a sidebar and two graphics elements. FullWrite's solution to this problem is for you to break the document into more chapters, but on a 1-megabyte machine, you may find yourself creating more chapters than you bargained for.

Other functions, such as the thesaurus and spelling checker, are also quick to run out of memory. I wouldn't recommend using FullWrite on a machine with less than 2 megabytes of memory, and you'll probably need even more for big jobs. According to Ashton-Tate, users working on documentation or other large projects should have at least 2.5 megabytes of RAM.

Since FullWrite runs best with lots of memory, BYTE's lab ran the word processing tests on the 4-megabyte Mac SE. In the keystroke count, search-and-replace, ASCII file conversion, and scrolling benchmarks, FullWrite fell behind MacWrite 5.0 and Word 3.01 (see table 1). In the search-and-replace test in particular, FullWrite lagged far behind Word and MacWrite. This function, on a 4K-byte test file, took 94 seconds—nearly four times longer than Word and three times longer than MacWrite. On the Mac II, this number dropped to a more tolerable 35 seconds.

FullWrite also fell behind when converting from ASCII to FullWrite format. Not surprisingly, these times improved substantially on the Mac II, taking 13 seconds to convert the 4K-byte test file from ASCII and just 4 seconds to convert it to ASCII.

During the scroll test, FullWrite paused to update the document at some page breaks while passing by others. These pauses occurred at different places each time I ran the test, and they accounted for a 20-second spread in the resulting test times. Ashton-Tate attributes the poor performance to FullWrite's inter-

continued

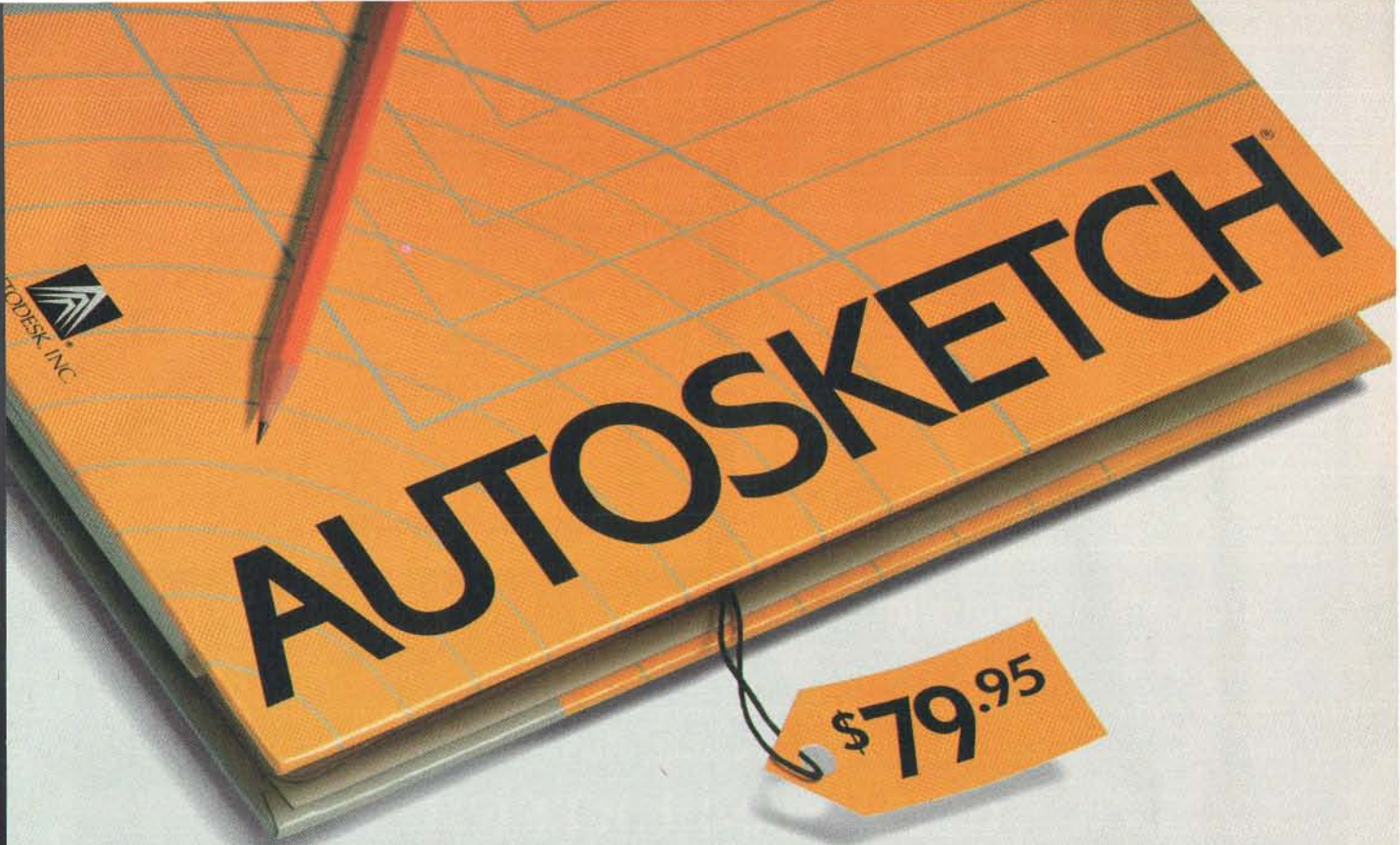

Now that the best name in CAD is this affordable, why settle for a generic brand?

What's in a name? When it comes to the Autodesk name, a lot. In fact, it's the best-selling, most well-respected name in the CAD business. There simply is not another company with the credentials to make that claim.

That's why you shouldn't settle for anything less than AutoSketch[®], the best way to get started in CAD. AutoSketch is the precision drawing tool from the Autodesk family of products. Not only is AutoSketch priced at just \$79.95,* but unlike some entry-level CAD products, you don't have to keep spending more to add the features AutoSketch already has. Standard features like boxes, circles, stretching, mirroring and rotating—to mathematical precision. And advanced CAD capabilities like dynamic PAN and ZOOM and automatic dimensioning and scaling, in up to 10 working layers.

Of course, if you do want to move up from AutoSketch at some point, your files can easily be uploaded into AutoCAD[®].

AutoSketch runs on IBM[®] PC/XT[™]/AT[®] and 100% compatible computers, and supports IBM's PS/2.[™]

So if you're ready for CAD, why not go with the name that rates highest among both critics and users? Anything else is, well, second-rate.

To order AutoSketch call 1-800-223-2521. For the name of your nearest AutoSketch Dealer or for more information, call 1-800-445-5415 Ext. 1 or write to AutoSketch, 2320 Marinship Way, Sausalito, CA 94965.

AUTODESK, INC.

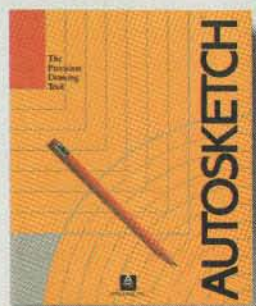

Circle 38 on Reader Service Card

*A speed-enhanced version (9 times faster), requiring a math coprocessor, is available for \$99.95.

AutoSketch and AutoCAD are registered in the U.S. Patent and Trademark Office by Autodesk, Inc. IBM and Personal Computer AT are registered trademarks of International Business Machines Corporation. Personal Computer XT and PS/2 are trademarks of International Business Machines Corporation.

Now Everyone Does Windows.

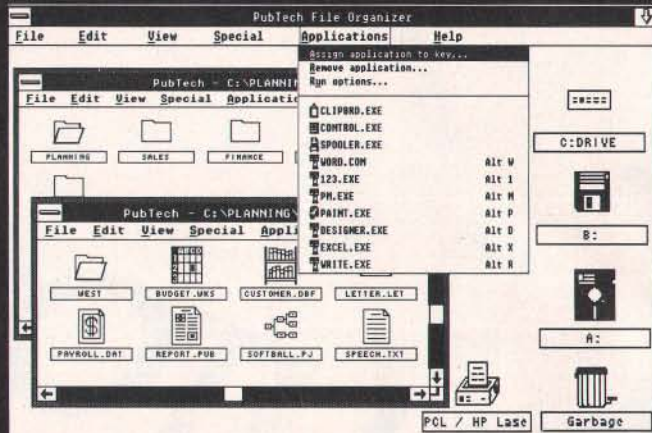
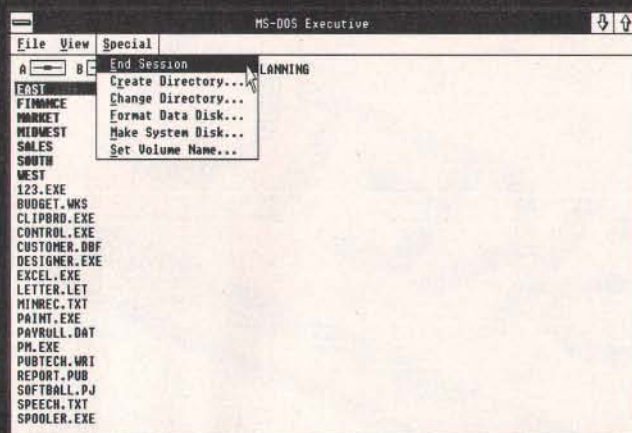

Turn MS-Windows into . . .

the PubTech™ File Organizer.

PubTech File Organizer. An icon-based extension of Microsoft Windows 2.03, 2.1 and 386. Integrating file management, backup & restore, application hot keys and other utilities all for \$145. With Windows 2.1, \$195. With Windows/386, \$245. With Logitech's M8 Serial Mouse, \$195.

See us at Fall COMDEX
Booth Number R8626

Call 1-800-PUBTECH

Publishing Technologies, Inc. 7719 Wood Hollow Dr., Suite 260 Austin, TX 78731

Microsoft and MS-Windows are trademarks of Microsoft, Inc. Logitech is a trademark of Logitech, Inc. PubTech is a trademark of Publishing Technologies, Inc.

REVIEW

FEATURES VS. SPEED

nal updating of the document; the company could not explain why the program's scroll performance varies with each test run. The number in the benchmark table (74 seconds) is an average, but even the fastest time—64 seconds—was substantially slower than MacWrite or Word. The Mac II, at 69 seconds, was only slightly better.

A related area where FullWrite falls down is during cursor movement using

the arrow keys on Mac SE and II keyboards. Text cursor movement works normally when you're using the mouse. But when you press one of the arrow keys, the text cursor moves even more slowly, and it disappears completely during the movement and doesn't reappear until a second or two after you've released the cursor-move key. This is aggravating, since you can't keep track of the cursor during moves.

An alternative is to use the Move menu, but this, too, is slow. The way around this is to use the keyboard shortcut keys, which instantly move the cursor to virtually any point in the document.

Professional writers and other heavy-duty text dumpers often sneer at Mac word processors because they claim it's a nuisance to keep taking your hands off the keyboard to steer a mouse. However, FullWrite provides a full complement of other keyboard shortcuts that range from text format and style selection to windowing and saving a document.

Minor Distractions

It's difficult to think of many features that Ashton-Tate left out of this package. One drawback is that columns are serpentine only; there's no easy way to do side-by-side columns. Anyone wanting to do two-column manuscripts can still manage; you have to define the second column as a sidebar and use the page-layout function to set it beside the main column of text. This requires some extra effort, however, and is a bit of a kludge.

FullWrite's WYSIWYG display mode

continued

Table 1: FullWrite's performance was lacking in several of the benchmarks.

	FullWrite 1.0	MacWrite 5.0	Microsoft Word 3.01
Keystroke count	203	177	185
Scroll	74	60	43
Search and replace	94	29	26
Reformat	2	8	<1
Save	3	5	2
Load	5	5	2
Word processing to ASCII	10	5	14
ASCII to word processing	25	15	16

Note: All tests were performed on a Mac SE using a mouse. File saves in Word were executed using the Fast Save option. All times are in seconds.

NEW

THE "DESKTOP PRESENTER PACK"



Everything you need for creating and giving presentations with your PC.

Now, you can make impressive, professional-quality, full-color presentations of any kind right at your desk with The DESKTOP PRESENTER PACK.

Everything you need is included: Colormetric® a high resolution graphics card for your PC, PictureIt™ business graphics software, and PCPrintmaker® desktop printing software.

With The DESKTOP PRESENTER PACK you will turn your personal computer into a full-capability workstation for creating professional-

quality presentations quickly and easily. Then use your PC to give a video presentation in 1000 colors.

Or make high resolution slides, overhead transparencies or hardcopy all in full-color by simply plugging in a SlideMaker® or color printer.

Buy the DESKTOP PRESENTER PACK and make the best presentation of your career.

See us at COMDEX
Call today 800-556-1234, ext. 234.
In Calif. 800-441-2345, ext. 234.

General Parametrics Corporation the makers of VideoShow

Berkeley, CA 415-524-3950

Circle 138 on Reader Service Card

NOVEMBER 1988 • BYTE 245

**You just
won another
big job.**

**Whose
software do
you trust
to control it?**

Since 1983, Primavera Project Planner has set the standard for project management software. That's why you can trust Primavera with the most important project in the world... yours.

Contact us for details on our newest features, including Import/Export from Lotus 1-2-3® and dBASE®, on-screen graphics with customizing capability, and pure logic networks.

**Software you can count on
to keep you in control.**



PRIMAVERA SYSTEMS, INC.
Project Management Software

Two Bala Plaza • Bala Cynwyd, PA 19004
(215) 667-8600 • Telex: 910 997 0484 • FAX: (215) 667-7894

displays fonts using fractional pixels. But the program may have a problem displaying some fonts if you're using a version of Font/DA Mover lower than version 3.6, because earlier versions corrupt fractional font measurement information. I used version 3.6, which worked fine, and version 3.4, which made some fonts appear rough or jagged-edged on-screen. But aside from the screen display, performance was unaffected; document layout, text processing, and font printing worked fine.

Other than my problems on the Mac Plus, no significant errors occurred while I was using FullWrite, and warning messages helped to prevent potential problems.

FullWrite is easy to learn and use, and the documentation is well designed and organized. The package includes a spiral-bound Learning Guide, a Reference Guide, and a Keyboard Shortcuts card. Notes, tips, and warnings are liberally sprinkled throughout both manuals.

If you get into trouble, Ashton-Tate includes 90 days of free technical support, provided you send in the registration card. The company also offers extended support, which entitles you to 15 calls for \$50 a year. A monthly graphics newsletter, *Random Lines*, is also available, as is electronic support via forums on CompuServe, The Source, and an Ashton-Tate bulletin board.

Bone of Contention

FullWrite is hard to beat on features, providing elements of MacDraw, PageMaker, and a sophisticated word processor in one package. Unless you're doing book-size projects, this package would probably suit your needs for both general word processing and desktop publishing functions. PageMaker is more powerful than FullWrite in terms of special effects and page layout, but FullWrite is more than adequate for most desktop publishing needs.

On the other hand, FullWrite has a ravenous appetite for memory, and it is a slow performer—especially during search-and-replace functions. It's best suited for Mac SE and II users with at least 2 megabytes of memory on-board. If you've got the resources and you're not looking for speed, however, FullWrite is worth a look. ■

Diana Gabaldon is the editor of Science Software and an assistant research professor at the Center for Environmental Studies at Arizona State University, Tempe, Arizona. She can be reached on BIX c/o "editors."

OCULUS™ - 10

*A real time
video digitizer
for the
VGA adapter.*

OCULUS™ - 10 lets you:

- Grab images of moving scenes into your computer
- From all standard cameras and VCR'S
- In either Monochrome or full, true colors
- With VGA resolution

Contrary to competing products which take several seconds to scan an image, **OCULUS™ - 10** grabs images in 1/20th of a second or less. Our software updates them on your VGA board at a rate of up to 10 images per second. **OCULUS™ - 10** gives you full freedom for:

- Digitizing images of live subjects
- Framing
- Focussing
- Selecting scenes from video recordings

Images can be saved in formats compatible with most electronic publishing and graphics software packages.

OCULUS™ - 10! A half-size add-on board for IBM-compatible micro-computers: PC, XT, AT, 386, and PS/2 models 25 and 30. The price? An unbelievable

\$495.

To order, fill out
the coupon, or call us:

IN THE US:
800-361-4914

OTHER:
(514) 333-1301

FAX:
(514) 333-1388

Specifications

On-board memory: 128 Kb
A/D converter: flash, 6 bits

FRAME-GRABBING TIMES:

Monochrome:

320 x 200, 4 bits: 1/60 second

320 x 200, 6 bits: 1/20 second

640 x 480, 4 bits: 1/30 second

Color: 320 x 200: 1/20 second

IBM, IBM-PC, XT, AT, PS/2 are trademarks of
International Business Machines Corporation.

Circle 373 on Reader Service Card



**ACTUAL UN-RETOUCHED PHOTOGRAPHS OF IMAGES
GRABBED BY OCULUS™ - 10**



**SUPPLIERS OF HIGH QUALITY
IMAGE PROCESSING PRODUCTS
SINCE 1983**

Mail to:

CORECO INC.

6969 Trans-Canada Highway
Unit 113, Saint-Laurent, Quebec, Canada
H4T 1V8

Please rush me an **OCULUS™ - 10** board, with utility software and Coreco's 3 months warranty, for \$495 (US currency) plus \$15 for shipping.

NAME:

ADDRESS:

STREET

CITY

STATE

ZIP

PHONE:

VISA MASTER CARD EXP:

CARD #

SIGNATURE:

Everything you see here...

12 MHz 80286
AT-Compatible
1Mb on-board DRAM
Full set of AT-compatible controllers
EGA/CGA/MDA/
Hercules compatible
HD/FD controllers
... and more

you see here. THE AMPRO LITTLE BOARD™/286

Big power for smaller systems.

Little Board/286 is the newest member of our family of MS-DOS compatible Single Board Systems. It gives you the power of an AT in the cubic inches of a half height 5 1/4" disk drive. It requires no backplane. It's a complete AT-compatible system that's functionally equivalent to the 5-board system above. But, in less than 6% of the volume. It runs all AT software. And its low-power requirement means high reliability and great performance in harsh environments.

Ideal for embedded & dedicated applications. The low power and tiny form factor of Little Board/286 are perfect for embedded microcomputer applications: data acquisition, controllers, portable instruments, telecommunications, diskless workstations, POS terminals... virtually anywhere that small size and complete AT hardware and software compatibility are an advantage.

Compare features.

Both systems offer:

- 12MHz CPU
- 512K or 1Mbyte on-board DRAM
- 80287 math co-processor option
- Full set of AT-compatible controllers
- 2 RS232C ports
- Parallel printer port
- Floppy disk controller
- EGA/CGA/MDA/Hercules video options
- AT-compatible bus expansion
- A wide range of expansion options
- IBM-compatible Award ROM BIOS

But only Little Board/286 offers:

- 5.75" x 8" form factor

- EGA/CGA/MDA/Hercules on a daughterboard with no increase in volume
- SCSI bus support for a wide variety of devices: Hard disk to bubble drives
- On-board 1Kbit serial EPROM. 512 bits available for OEMs
- Two byte-wide sockets for EPROM/RAM/NOVRAM expansion (usable as on-board solid-state disk)
- Single voltage operation (+5 VDC only)
- Less than 10W power consumption
- 0-60°C operating range

Trademarks: AT & PC—IBM Corp.; Hercules—Hercules Comp. Tech., Inc.; MS-DOS—Microsoft Corp.; Little Board—Ampro Computers, Inc.

Better answers for OEMs.

Little Board/286 is not only a smaller answer, it's a better answer... offering the packaging flexibility, reliability, low power consumption and I/O capabilities OEMs need... at a very attractive price. And like all Ampro Little Board products, Little Board/286 is available through representatives nationwide, and worldwide. For more information and the name of your nearest Rep, call us today at the number below. Or, write for Ampro Little Board/286 product literature.

408-734-2800

Fax: 408-734-2939 TLX: 4940302

AMPRO
COMPUTERS, INCORPORATED
1130 Mountain View/Alviso Road
Sunnyvale, CA 94089

Remote-Control Communications



Crosstalk's Remote² lets you control another computer via your modem

Rick Cook and Paul Schauble

A remote-control communications program is indispensable for anyone doing software support over the telephone. It lets you use a modem to look over the user's shoulder to examine the system as it runs, enter commands, and check screen displays. The program is an enormous asset if you do software maintenance or support, and it is ideal for walking a user through a sequence of instructions.

One such remote-control program is Remote² 1.0 (\$195) from the Crosstalk division of DCA in Roswell, Georgia. It consists of a program called R2Host, which runs on the user's machine, and R2Call, which calls into the remote computer. The programs run on MS-DOS systems in as little as 36K bytes of RAM.

Remote-control programs are definitely useful, but they are very difficult to write. In essence, they are the ultimate terminate-and-stay-resident (TSR) programs in that they go far beyond anything MS-DOS was ever intended to do. They must wedge themselves invisibly between the applications and the operating system and transmit every keystroke and every pixel through a communications port to another computer.

The remote caller needs to be able to do everything the user can do from the keyboard, as well as see everything on a remote display. Ideally, the remote program should be absolutely invisible to the user's system. Everything should operate

exactly as it does when the remote-control program is not loaded.

Unfortunately, no remote-control program is that good. Like all remote programs, the R2Call/R2Host system has inherent drawbacks; however, it also has some problems all its own, especially in the way it handles screen displays.

In addition to running a computer remotely, R2Call/R2Host also provides a number of other features, such as file compression and error-corrected transmission, password and callback features for security, and a simple but useful session management function that includes maintaining a comprehensive call log.

R2Call/R2Host works over a modem or over a direct serial link. It handles both Hayes-compatible and non-Hayes-compatible modems. R2Host can handle calls from systems without R2Call, but it must run DCA's Crosstalk XV communications package. The program includes a reference card for the key combinations used to simulate control, escape, and other key combinations when running with Crosstalk. R2Host will even accept calls generated by about a dozen types of terminals, including the ADM-3A, the VT-220, and the IBM 3161.

We tested R2Call/R2Host on an Everex 386 PC running at 16 MHz with a USRobotics 2400-bit-per-second modem, and on an IBM PC switchable between 4.7 MHz and 8 MHz with a DataFox 2400-bps modem. For the CGA tests, we used a Leading Edge Model M with the DataFox modem instead of the IBM PC. We also tested the programs using a serial cable and a null modem connection between the computers' serial ports running at 19,200 bps. We had no problems with either the modems or the cables that could be attributable to the software.

Installation

One of the best things about R2Call/R2Host is the installation program. In-

continued

Back, by popular demand.

Just a few years ago, illegal hunting and encroaching civilization had all but destroyed the alligator population in the south. They were added to the official list of endangered species in the United States.

Now alligators have made a comeback.



Conservationists intent on preserving this legendary reptile helped the alligator get back on its feet. Once again some southern swamps and marshes are teeming with alligators.

With wise conservation policies, other endangered species have also made comebacks... the cougar, gray whale, Pacific walrus, wood duck, to name a few.

If you want to help save our endangered species, join the National Wildlife Federation, Department 106, 1412 16th Street, NW, Washington, DC 20036.



Remote² 1.0

Type

Communications program

Company

Crosstalk Communications/DCA
1000 Holcomb Woods Pkwy.
Suite 440
Roswell, GA 30076
(404) 998-3998

Format

Two 5¼-inch floppy disks

Language

Assembly

Hardware Needed

IBM PC or compatible with at least 36K bytes of memory above that needed for the application software

Documentation

131-page R2Host manual; 107-page R2Call manual; quick reference card

Price

System (combined host and caller):
\$195
Host only: \$129
Caller only: \$89

Inquiry 889.

stead of presenting a series of cryptic questions, it gives a screenful of text at each decision point that fully explains your choices and their consequences.

For example, if you install the program to run over a serial link, the modem test step in the installation process naturally fails. The program not only tells you it failed, it also tells you this is normal and then warns you that it can't be sure everything is connected properly.

Best of all, R2Call/R2Host asks your permission before adding something to your AUTOEXEC.BAT file. People with painstakingly crafted scripts in their AUTOEXEC.BAT files can tell the program not to mess with them, while average users don't have to make manual changes to the file.

The documentation that comes with the program is very good. It is clear, concise, and effective at explaining the basic features of both programs.

For all its ease of installation, though, you can't expect an inexperienced user to successfully install R2Host without some hand-holding. There are just too many parameters that have to be set. This is inherent in programs of this type,

which is unfortunate, because R2Host is the program that has to run on the machine to be accessed (i.e., the one that will be out in the field).

One peculiarity developed when we set up our test systems. The 80386 machine was running an EGA-compatible Sigma Color 400 card and a color monitor, but it also had a monochrome card installed. Although we told the installation program we wanted a color display on that system and a monochrome display on the other system, R2Call/R2Host insisted on displaying through the monochrome card on the color system. And it wasn't until we plugged a monochrome monitor into the monochrome card that we got a screen display.

This is deliberate, according to Crosstalk. However, there's no message telling the user what is going on. If you don't have your monochrome monitor hooked up and turned on, you have no idea what is happening.

Graphics Drawbacks

Most of the problems we encountered with R2Call/R2Host were related to the screen display, especially trying to work with anything other than monochrome monitors.

The program does not claim to support EGA or VGA graphics. It doesn't support Hercules-style high-resolution monochrome graphics, and it treats cards that display CGA on monochrome monitors as simple monochrome displays.

R2Call/R2Host does support CGA-to-CGA connections in character and graphics modes, albeit with some limitations. When we tried running Lotus 1-2-3 graphics, the system running R2Call locked up, and the screen of the system with R2Host had its foreground color set to 0, leaving a completely blank screen. Both systems had to be reset.

Once again, this is a severe test. Lotus is notorious for handling graphics in a nonstandard and hardware-specific way, so failure was likely. The manual does warn that programs that do direct hardware calls for graphics may not work.

In practice, there were more limits than the ones the manual warned against. The program handles CGA all right, but only CGA to CGA, at least in character mode. (You can use an EGA card in CGA-emulation mode.) R2Call/R2Host had no problem with spreadsheets and text between CGA systems.

Although the program is supposed to handle CGA-to-CGA graphics, we found that they didn't always work. We attempted to run some of the demonstra-

continued

CHEAP!



ZENITH

- SUPERSPORT 2 Drive \$ 1498
- SUPERSPORT 20MB HD \$ 2197
- SUPERSPORT 286 20M \$ 3034
- SUPERSPORT 286 40M \$ 3376



CALL FOR THE CHEAPEST PRICES ON ALL POPULAR LASER PRINTERS.



NEC MULTISYNC II \$549



- 6300 WGS 1 Drive \$ 989
- 6300 WGS 30M \$ 1268
- 6386 WGS \$ 3326



EPSON

- Equity I+ \$ 688
- Equity II+ \$1039
- Equity III+ \$1344
- LT Laptop Dual Drive \$1189
- LT Laptop 20M Harddisk \$1792

NEC

- Powermate**
- 120M \$ 1198
 - 386/16 \$ 1527
 - 386/16 \$ 2585
 - 386/20 \$ 3299



All Original NEC Composite All Models Include Keyboard

NEC

- Powermate Portable 20M \$ 2358
- Powermate Portable 40M \$ 2744
- Powermate Port. SX 42M \$ 2594
- Powermate Port. SX 140M \$ 3429
- Multispeed EL II \$ 1419
- Multispeed HD \$ 2248

TOSHIBA



- T1000 \$ 777
- T1100 PLUS \$ 1388
- T1200F \$ 1579
- T1200H 20M \$ 2259
- T3100/20 \$ 2987
- T3200 \$ 3744
- T5100 \$ 4784

HARD DISK DRIVES

- EAGATE 2M w/Cont \$ 267
- 2M w/Cont \$ 276
- 2M w/Cont \$ 444
- 4M \$ 448
- 1M \$ 659
- MINISCRIBE 2M w/Cont \$ 334
- 2M #3650 \$ 298
- 1M 28ms \$ 659
- 1M 28ms \$ 748
- MICROPOLIS 3M 23ms w/Cont \$ 1594
- 2M 18ms w/Cont \$ 2389

DISK DRIVES

- PLUS**
- 20M Hardcard \$ 498
 - 40M Hardcard \$ 629
- TOSHIBA**
- 3.5" 720K \$ 88
 - 3.5" 1.44M \$ 126
 - 5.25" 360K \$ 89
 - 5.25" 1.2M \$ 89
 - AMR 5.25" for PS/2 \$ 239
 - ANDEK Laserdrive with MS Bookshelf \$ 799

MODEMS

- HAYES**
- 1200B Internal \$ 229
 - 2400B Internal \$ 368
 - 1200 External \$ 268
 - 2400 External \$ 397
 - 2400P PS/2 \$ 359
- US ROBOTICS**
- 1200 Internal \$ 88
 - 2400 Internal \$ 164
 - 1200 External \$ 99
 - 2400 External \$ 166
 - Courier 2400 PS/2 \$ 277
- VENTEL**
- 2400B for PS/2 \$ 348

VIDEO CARDS

- Boca EGA \$ 144
- Hercules Mono \$ 169
- Hercules Color \$ 139
- Hercules INColor \$ 266
- NEC GB-I \$ 268
- Nitro Monographic \$ 49
- Nitro Color Card \$ 49
- Paradise VGA 480 \$ 172
- Paradise VGA Plus \$ 269
- PGS Laserpage \$ 532
- PGS PG-1600 \$ 532
- Video-7 Vega VGA \$ 269

SAMSUNG

- S-300 \$ 649
- 8 MHzXT Compatible 360K Drive, 6 Exp Slots
- S-500 \$ 1098
- 10 MHz AT Compatible 1.2M Drive, 8 Exp Slots
- S-800 \$ 2598
- 20 MHz 80386 1.2M Drive, 8 Exp Slots EGA Video Adapter

AST COMPUTER SYSTEMS

- 286 Model 80 \$ 1539
- 286 Model 90 \$ 2039
- 286 Model 120 \$ 2355
- 286 Model 140 \$ 2677
- 286 Model 170 \$ 3089
- 286 Model 300 \$ 2699
- 386 Model 340 \$ 3999
- 386 Model 390 \$ 5349
- 386 Model 3150 \$ 6149
- 386 Model 3320 \$ 6788

PRINTER	NEC PRINTERS	CITIZEN PRINTERS	EPSON PRINTERS	OKIDATA PRINTERS	PANASONIC PRINTERS	PRINTERS
	P6 10" wide \$ 463	1200 \$ 184	LX-800 \$ 189	182 PLUS \$ 224	KX-P1080 \$ 198	AST TurboLaser/PS \$ 3383
	CP6 10" Color \$ 549	1800 \$ 199	FX-850 \$ 339	192 PLUS \$ 318	KX-P1091 \$ 218	DICONIX 150 \$ 332
	P7 16" wide \$ 644	1800 \$ 733	FX-1050 \$ 268	193 PLUS \$ 412	KX-P1092 \$ 344	DICONIX 300W \$ 515
	CP7 16" Color \$ 733	MSP-10 \$ 359	FX-86E \$ 369	292 IBM Parallel \$ 416	KX-P1592 \$ 436	GENICOM 4410 400 lpm \$ 4689
	P2200 10" wide \$ 359	MSP-15E \$ 369	FX-286E \$ 469	294 Color Parallel \$ 533	KX-P1595 \$ 492	4440 800 lpm \$ 5979
	P5XL 16" Color \$ 877	MSP-40 \$ 488	LQ-500 \$ 328	294 Color Parallel \$ 754	KX-P1524 \$ 555	OTC 850XL \$ 1644
	P9XL 16" Color \$ 1079	MSP-45 \$ 422	LQ-850 \$ 519	393 \$ 877	KX-P1524 \$ 555	XEROX 4020 Color \$ 1088
	LC890 Silentwriter \$ 3433	MSP-55 \$ 551	LQ-950 \$ 597	393 Color \$ 939	KX-P3131 17 cps \$ 327	
	ELF-350 19 cps \$ 417	Premiere 35 \$ 533	LQ-1050 \$ 737	LASERLINE 6 Par \$ 1348	KX-P3151 22 cps \$ 519	
	3500 35 cps \$ 896	Tribute 124 \$ 498	LQ-2550 Color \$ 939		Laser Partner \$ 1738	
	8800 55 cps \$ 1166	Tribute 224 \$ 664				

SOFTWARE

- Adus Pagemaker 3.0 \$ 488
- Carbon Copy \$ 109
- Zipper \$ 395
- Crosstalk 16 \$ 98
- DBXL Diamond Rel. \$ 118
- Deskview 2.0 \$ 77
- Disk Optimizer \$ 44
- Eureka \$ 98
- Fastback Plus \$ 94
- Foxbase Plus \$ 196
- Foxbase Plus 386 \$ 288
- Generic CADD \$ 78
- Generic CADD \$ 78
- Gings Quest \$ 34
- Managing Money \$ 119
- Microsoft CS.1 \$ 281
- MS QuickBasic \$ 64

SOFTWARE

- Microsoft EXCEL \$ 296
- Microsoft Word 4 \$ 209
- Microsoft Works \$ 114
- Microsoft Write \$ 119
- MS Windows 2.0 \$ 68
- MS Windows 386 \$ 123
- MS Flight Simulator \$ 34
- Windows Toolkit 2 \$ 329
- MS Macro Asm 5.1 \$ 98
- Newsroom \$ 36
- Paradox 1.1 \$ 282
- Paradox 2.0 \$ 387
- PFS: Pro Write \$ 139
- PFS: First Choice \$ 88
- Q & A \$ 189
- Quattro \$ 144

SOFTWARE

- Xerox Ventura Publ \$ 474
- Quicksilver Diam Rel. \$ 337
- Reflex \$ 87
- Sideways \$ 43
- Smart Notes \$ 52
- SQZ Plus \$ 62
- Supercal 4 \$ 259
- Turbo Basic \$ 59
- Turbo C \$ 59
- Turbo Lightning \$ 59
- Turbo Pascal 4.0 \$ 59
- Turbo Prolog \$ 84
- VP Planner \$ 58
- Word Perfect 5.0 \$ 235
- Wordstar Prof. \$ 218
- Yeager Adv Flight \$ 29

MONITORS

- Amdek 410A \$ 138
- 432 VGA Mono \$ 156
- 732 VGA Color \$ 414
- 1280 & video card \$ 638
- AST Monochrome \$ 129
- AST EGA Color \$ 477
- Epson Mono \$ 114
- Epson Color \$ 288
- Epson EGA Color \$ 368
- Genius Diap Sys \$ 1288
- NEC Monograph \$ 1244
- NEC Multisync XL \$ 2075

MONITORS

- NEC Multisync II \$ 549
- NEC Multisync GS \$ 179
- NEC Multisync Plus \$ 858
- PGS HX-12 \$ 436
- PGS Max-15 \$ 264
- PGS LM-300 \$ 538
- PGS Ultrasync \$ 539
- Taxan Crystal View \$ 1434
- WYSE WY-700 \$ 717
- Zenith 149 \$ 109
- Zenith 1390 \$ 419
- Zenith 1490 \$ 584

ACCESSORIES

- Printer Cable 6' \$ 9
- Printer Cable 10' \$ 14
- Parallel Adapter \$ 29
- Serial Adapter \$ 29
- Game Adapter \$ 19
- 101 Keyboard \$ 68
- PS/2 Keyboard Exten \$ 16
- PS/2 Monitor Exten \$ 21
- Xidex DS/DD Disks \$ 7
- Xidex 1.2M Disks \$ 13
- IBM 3.5" 1M Disks \$ 29
- IBM 3.5" 2M Disks \$ 58

SCANNERS

- EP Scanjet w/Int \$ 1178
- EST TurboScan \$ 1233
- EST Scan Plus \$ 1798
- anasonic OCR \$ 1798
- GS L3300 w/Int \$ 698
- GS L3300 OCR \$ 939

INTEL

- 8087 4.77MHz \$ 99
- 8087 8 MHz \$ 142
- 80287 6 MHz \$ 179
- 80287 8 MHz \$ 243
- 80287 10 MHz \$ 289
- 80387 16 MHz \$ 448
- 80387 20 MHz \$ 689
- 80387 20 MHz \$ 349
- Above Bd 286 512K \$ 249
- Above Bd PS/2 OK \$ 889
- Joboard 386/PC Kit \$ 988
- Joboard 386/AT Kit \$ 988

MOUSE DEVICES

- MICROSOFT Mouse \$ 97
- With Windows 2.0 \$ 138
- LOGITECH Mouse \$ 74
- With LogiCADD \$ 118
- Publisher Mouse \$ 113
- HiRes Mouse \$ 86

HOURS (E.S.T.)
8-7 Monday-Friday
12-5 Saturday

NITRO MICRO

120 West Main Street • CARMEL, IN 46032

800-382-3888



Please add 3% for shipping & handling. NO SURCHARGE FOR CREDIT CARDS and we do not charge until we ship. All items subject to availability and price change. All standard orders are sent UPS.



tion programs supplied with QuickBASIC 4.0. Some of them ran, and some of them didn't. Animation programs produced screen snapshots rather than moving objects. However, programs that drew a Mandelbrot set and a sine wave worked.

We also tested a character-based game on a CGA host and a monochrome remote; it didn't work. What we got was pieces of the command-line text scattered throughout the remote's display. Given the proliferation of color displays, the requirement that the displays match is a fairly serious limitation. It makes it difficult to use the product to communicate with remote computers, and that is, after all, the reason it exists.

This is further complicated by the way R2Call/R2Host behaves when things do go wrong. Don't expect warning messages or simple refusals to function here. When R2Call/R2Host fails, it almost always fails hard, locking up one or both machines. Since failures are so likely, it would have been nice if they were cushioned in some way—at least with a warning message for when the user is about to try something chancy or, preferably, by refusing to run dangerous programs.

Crosstalk says it is addressing this problem in the next version of the product (1.1), which should be out by the end of the year. But don't expect the problem to go away entirely.

Unsettling Screens

The display incompatibilities weren't the only problem with R2Call/R2Host displays. The screen updating is an invitation to a migraine.

You can see what is going on with the remote system, but don't plan on looking at it for very long. The display updating is an annoying, eye-straining mess.

Screen updates are slow, of course. Even over a 19,200-bps serial link, the display can't be expected to match the speed of a memory-mapped PC display. This means that if you are typing text into a word processor, for example, the screen will lag by several characters.

But that doesn't excuse the jerky, crazy way the display is updated on R2Call/R2Host. When you enter text, the screen does nothing for the better part of a second, and then the display jerks ahead with a burst of characters. The effect is extremely unsettling and makes it hard for even a moderately fast typist to work at the system.

Worse, entering commands on the command line is difficult. If you make a lot of mistakes, you don't catch them because you can't see them until you've

reached the end of a command. If you've already hit Enter out of reflex, you get an error and have to reenter the command.

Still worse, the cursor position bears little or no relationship to where the screen is updating. When typing in text, sometimes the cursor is behind the characters as they flash on the screen and sometimes it is ahead. The effect is extremely distracting.

To top things off, in a screen redraw, parts of the screen appear seemingly at random while the old screen remains visible. In running QuickBASIC demonstration programs, for instance, often the bottom third of the screen would show up first, followed by the top, and then the middle. Usually there would be parts of both screens visible at the same time for several seconds. Using, say, WordPerfect 4.2 to type half a screen of text could drive you nuts.

According to Crosstalk, programs that use the BIOS routines to move the cursor should be smoother, though few of the most powerful application programs work that way. Crosstalk also says that the revised version should be better with all kinds of programs.

Remote Applications

With the exception of the screen update problem, when R2Call/R2Host works, it works well.

R2Call/R2Host maps the keyboard of the calling machine exactly onto the host computer: An Escape on the host is an Escape on the calling machine, and so on. The caller doesn't have to remember a separate set of keycodes for the host, and this makes things more intuitive for the caller. For callers using Crosstalk rather than R2Call, there is a set of alternate key combinations for the various special keys, all spelled out in a reference card that comes with the package.

Also on the plus side, R2Call/R2Host ran perfectly with our local-area network, an ARCnet running Novell NetWare. We had no problems manipulating the network with either program.

However, some application programs did not work. Once again, some of this is to be expected. TSR programs, or programs that write directly to the hardware, make odd function calls, or otherwise behave badly, are always chancy on systems where MS-DOS has been pushed beyond its design limits. The manual specifically warns about several potential problem areas.

However, in some cases, we could not figure out why a program failed. FinalWord 2.0, for example, would not run. It would load, and the screen would come

up, but neither system could move the cursor off the command line or produce any other response. The calling system finally had to be rebooted for us to get out of it.

FinalWord is a solid word processor that does not have a reputation for doing odd things to computers. Neither we nor Crosstalk have an explanation for its failure to run. Therefore, we recommend that before buying Remote², you check the compatibility of the applications you intend to run.

In contrast, WordPerfect 4.2 worked normally—given the irritating display. Microsoft's QuickBASIC also ran without a problem.

Except for the graphics, Lotus 1-2-3 also worked normally over R2Call/R2Host. We could load 1-2-3 over the network, create or call up spreadsheets, and then manipulate them from either computer.

File transfers were trouble-free. Both archived (compressed) and text files moved both ways quickly and smoothly. There was a small difference in transferring from the 80386 to the PC versus from the PC to the 80386, but not much.

There is a real need for a program like R2Call/R2Host. If you are doing software support for remote locations, it is a great time saver.

R2Call/R2Host gets very high marks for its installation program and for its manuals. Its functionality, however, is less satisfactory. Generally, it can be recommended only if you don't have to stare at the screen for a long time and if you are thoroughly familiar with both the host and target systems, as well as the software you are running and how it interacts with R2Call/R2Host. Otherwise, you will waste a lot of time trying to decide what is a problem with the application and what is an artifact of the R2Call/R2Host connection.

At the very least, Crosstalk needs to do something about the horrible screen updates and install some kind of warning or interrupt system to keep incompatible programs from crashing the systems. It would be nice if the company could add better support for mixed-mode and non-monochrome displays as well. ■

Rick Cook is a freelance writer living in Phoenix, Arizona, specializing in computers and high technology. He can be reached on BIX as "rcook." Paul Schauble is an independent program developer living in Glendale, Arizona, who has been working with Unix-based systems for over 10 years. He can be reached on BIX as "pls."

REAL CADD FOR YOUR MAC... JUST \$99.95!

**Affordable CADD. And it's
only the beginning.**

The CADD stands for Computer Aided Design and Drafting. With a suggested retail price of just \$99.95, Generic CADD Level 1 makes the power of real CADD affordable. And it's just part of a family of Generic CADD products that will make you more productive than ever before.

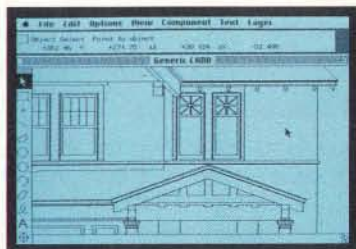

**Standard Mac interface for
ease of use.**

Now you can produce accurate drawings with real world scale on the Mac Plus, Mac SE, or Mac II. You can edit multiple drawings in separate windows and cut and paste between them. CADD Level 1 is also multifinder compatible.

**Symbol Libraries boost
productivity.**

From office furniture to specialized electronics symbols, our Symbol Libraries save you the time of redrawing repetitive elements every time you need them.

**Add the power of real CADD
to your Mac.**

Move your Macintosh drawings into the real world. Call us at 1-800-228-3601 for your free CADDalog or the name of your Generic dealer. And find out why we say the only thing generic about us is the price.

© 1988 Generic Software, Inc. Generic CADD Level 1 is not copy protected and comes with a 60-day money back guarantee. Registered users get free technical support from Generic.

Level 1 and Generic CADD are trademarks of Generic Software, Inc. Macintosh is a trademark of the Apple Computer Corp.

11911 North Creek Parkway South, Bothell, WA 98011

**Circle 139 on Reader Service Card
(DEALERS: 140)**

Generic
S O F T W A R E

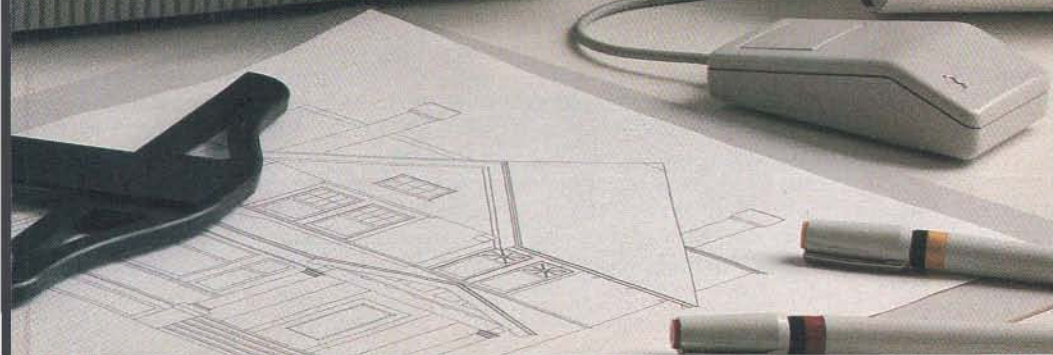
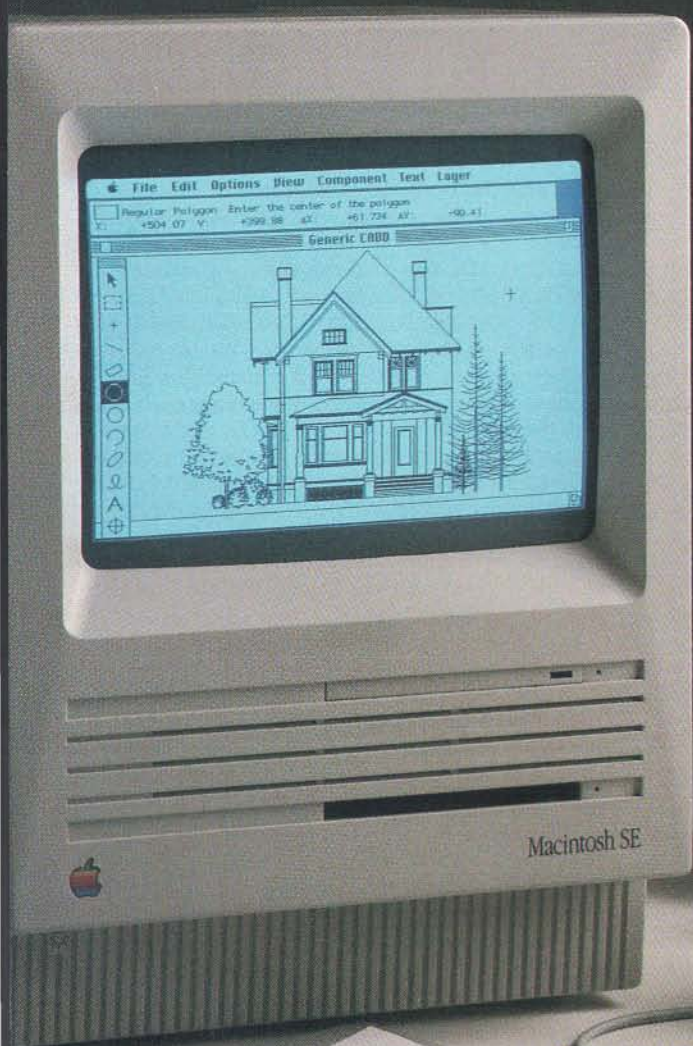

80386 Clones Revisited

Northgate's Affordable 80386

Our October Product Focus uncovered some outstanding machines among the 20 low-cost 80386 clones we reviewed. But few of those receive the kind of publicity generated by Northgate's offering, a 16-MHz system retailing for an even \$3000. Among our requirements for inclusion in that review were that the system come in complete usable configuration, with a monitor, a keyboard, at least one floppy disk drive, and at least a 40-megabyte hard disk drive. Although the Northgate system arrived too late for that review, it eventually came equipped with all that we asked for, and more.

Like many of the top-performing systems we reviewed, the Northgate 386 is built around the AMI/Mylex 386 motherboard. The board comes with 1 megabyte of 120-nanosecond DRAM and a 64K-byte SRAM cache. Caching allows performance at 16 MHz with zero wait states. The design earned the system a 2.61 CPU index on our benchmarks, tying it with the Zeos 386 Tower and the Spear Mono-386A for one of the highest ratings among the 16-MHz systems.

Unfortunately, all this processing power comes at a price: The board's layout limits future expansion. The system supports only an 80287 coprocessor (an 80387 can be added using a daughterboard), the 32-bit memory ceiling is set at a low 4 megabytes, and memory upgrades must be done by the manufacturer.

Northgate's most highly touted feature is its 65-megabyte MiniScribe 3650R hard disk drive, coupled with an Adaptec 2372 controller that allows run-length-limited encoding at a 1-to-1 interleave. Only Zeos, using the same controller, was able to match Northgate's hard disk capacity.

The drive's actual access time specs are not outstanding at 40 milliseconds, but Northgate claims that its drive/controller subsystem attains high throughput. Our disk benchmarks, which consider both access time and throughput, gave the combination a disk index of 1.38, about average for 40-ms drives.

Application benchmark results were mixed, with the drive scoring well on the relatively disk-intensive Spreadsheet tests (2.75) but giving a poor showing of 1.34 on the most disk-intensive Database benchmarks. Zeos's 386 system, using the Adaptec with a Seagate ST277R drive, turned in a better disk performance overall.

It's hard to rate qualitative features like monitor clarity and keyboard feel, but the most outstanding part of the Northgate design may well be the ergonomics. The 102-key keyboard has an excellent tactile response, and the keys are generally positioned for comfortable typing. The 14-inch white-phosphor flat-screen monitor looks and acts like the fine Everex model.

On the whole, the system was a solid performer. Its combined application index of 10.05 put it right beside the Spear machine and ranked it seventh out of the 21 reviewed clones. The whole Northgate package, which includes DOS 3.30 and GWBASIC, is well put together and a good buy for \$3000. In terms of sheer performance, though, there's little to distinguish it from the rest of the high-speed crowd.—*Steve Apiki*

Apple's Scanner

Since the October review of low-cost Mac scanners, Apple has introduced its own Apple scanner, priced at \$1799. Like the competing scanners, it closely resembles a flatbed copier. The Apple Scanner requires no external power supply or SCSI adapter box; a power cord (supplied), SCSI terminator, and SCSI adapter cable (not supplied) get you set up. You can change the scanner's SCSI ID with a push-button selector dial if it conflicts with another SCSI peripheral.

The scanner can handle an 8½-by-14-inch document scanned in as line art, as a halftone, or as a 4-bit-per-pixel gray-scale image, for 16 gray levels. Scanning resolution (from 75 to 300 dots per inch) is user selectable, and you can save the image as PICT2, Tagged Image File Format, or MacPaint files. However, you

can't open files saved as TIFF or MacPaint. I can understand this limitation for MacPaint files, since information is lost saving the image as a 72-dpi black-and-white MacPaint image, but the inability to open TIFF files doesn't make much sense.

Three disks of software are supplied. The first contains a VideoWorks II tutorial. The second disk has the AppleScan application, Scanner INIT, and LaserPrep/LaserWriter 5.2 driver files. The third disk holds the Scanner INIT and HyperScan, a HyperCard version of AppleScan for use with HyperCard 1.2.

I tried the AppleScan application on a Mac II with 5 megabytes of memory, an AppleColor monitor, and a Mac II video board. Scanning times were slow (about 47 seconds for an 8½-by-14-inch line scan, and nearly 2 minutes for a gray-scale scan of the same image), but the quality is very good. The application is reliable—no system bombs. The manual doesn't tell you that you must first convert gray-scale images to halftone images before you can print them. But printing to a LaserWriter IINTX worked fine, and the quality of the images is excellent.

I also tried Caere Corp.'s OmniPage optical-character-recognition application, priced at \$795, with the Apple Scanner. It requires 4 megabytes of RAM and a 68020 processor (either a Mac II or a Mac SE with a 68020 accelerator board). The OmniScan OCR application drives the Apple Scanner directly. You can select either image scan (200, 240, and 300 dpi) or text scan (300 dpi).

I let OmniScan do a text scan on several pages from BYTE. The application automatically recognized the columns of imaged text, even when the font changed, and converted them to ASCII text. Alignment, as the manual points out, is critical. If the page is misaligned even a few degrees, the character-recognition software generates spurious characters. As you might expect, OmniPage does a better job on large-size text with a simple typeface (such as Helvetica). While by no means perfect, OmniPage goes a long way toward automating document scanning.—*Tom Thompson*

JAMECO

ELECTRONICS

1989

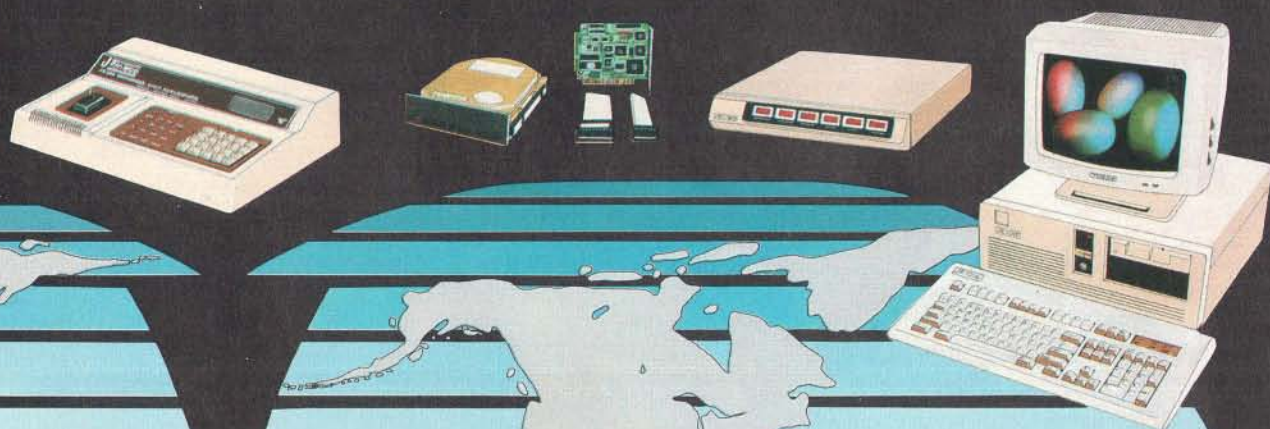

PURCHASING

TECHNICAL SERVICE

MARKETING & ACCOUNTING

PACKING & SHIPPING DEPARTMENT

MAIL ORDER ELECTRONICS — WORLDWIDE

NEW!

AMI 80386 MOTHERBOARDS

NEW!

One-Year Warranty!

64K High Speed RAM Cache

Speaker Output Keyboard Lock and Front Panel LED Connections

Advanced AMI BIOS ROMs (AT Compatible)

Expandable to 10 Meg!

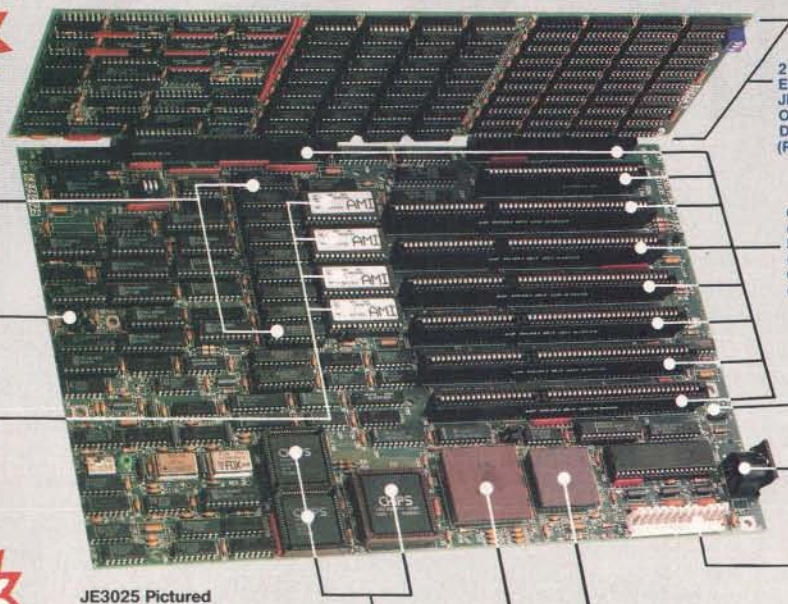

2 Megabyte (Zero-K RAM) 32-Bit Expansion Card included with JE3020 and JE3025 — Optional 8 Megabyte Daughterboard Available (Part No. JE3030) See Below

One 32-Bit Expansion (Bus) Slot
Six 16-Bit Expansion (Bus) Slots
One 8-Bit Expansion (Bus) Slot

External Battery Connector

Keyboard Port

Standard Power Connector

JE3025 Pictured

State-of-the-Art VLSI Circuitry (Very Large Scale Integration)

80386 CPU (Central Processing Unit)

Optional 80387-20 Math Coprocessor — Not Included (See page 438)

80386 Power and AT Compatibility in an XT Footprint!

The AMI 80386 motherboards are available in either 16MHz or 20MHz versions. The AMI 80386 motherboards fit into an XT, AT or Baby AT chassis so that the board delivers 386 power/performance and AT compatibility in an XT footprint size. The motherboards are ideally suited for a variety of applications including Multiuser (Unix, Xenix, PC MOS), Networking (Novell, 3-Com), CAD applications (Autocad) and Multitasking (Windows, OS/2, Desqview). The board features one 8-bit slot, six 16-bit slots and one 32-bit slot as well as 80387-20 math co-processor capability for the JE3025 and 80387-16 for the JE3020. Both motherboards are keyboard switchable between low and high speed and 1 or 0 wait states. The 20MHz board features a Norton SI rating of 24.2 in the 20MHz mode, while the 16MHz board features a Norton SI rating of 18.7 in the 16MHz mode. AMI BIOS ROMs are included. RAM is mounted on a 32-bit expansion card (included) which utilizes (72) 41256-100 (JE3025) 256K chips to reach 2 Megabytes (the JE3020 utilizes 41256-120 chips). A daughterboard is available (Part No. JE3030) which accepts (72) 511000P-10 1Meg chips for an additional 8 Megabytes, bringing the total memory of the system to 10 Megabytes. BIOS options include built-in set-up and diagnostics. Special features include 64K of high speed static cache RAM on the motherboard and the AMI EGA BIOS which allows for incredibly fast EGA performance when shadowed. • Size: 8.5" x 13" • Weight: 4 lbs. • One-Year Warranty

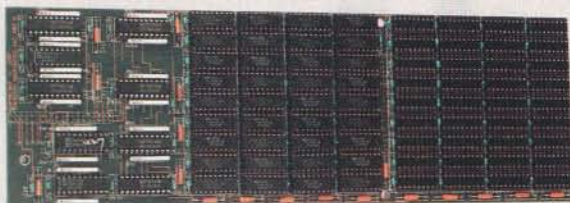

JE3030 — 8 Megabyte Daughterboard Option (Zero-K RAM)

RELATIVE PERFORMANCE

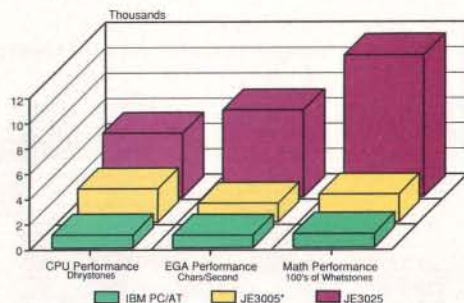

* See next page.

Part No.	Description	Price
JE3020	16MHz 80386 AT Compatible Motherboard (Zero-K RAM).	\$1399.95
JE3025	20MHz 80386 AT Compatible Motherboard (Zero-K RAM).	\$1699.95
JE3030	8 Megabyte Daughterboard for JE3020 and JE3025 (Zero-K RAM).	\$299.95

256 **For complete product line, request Jameco's new 74 page 1989 Catalog**

IBM AT Compatible 12MHz 80286 Motherboard

- Expandable to 1MB RAM using 256K DRAM chips☆
- Expandable to 4MB RAM using 1MB DRAM chips☆
- Expandable to 2.5MB RAM using a combination of 256K and 1MB DRAM chips☆
- 8 or 12MHz hardware or keyboard selectable operation
- Front panel LED indicators supported
- Six 16-bit and two 8-bit expansion bus slots
- AMI BIOS ROMs included
- Zero wait states
- Selectable RAM chip speed (80 or 100 nanosecond)
- 80287-8 Math Co-processor capability☆
- Norton SI rating of 13.7
- Size: 13" x 8.75"
- Weight: 2.25 lbs.

One Year Warranty!

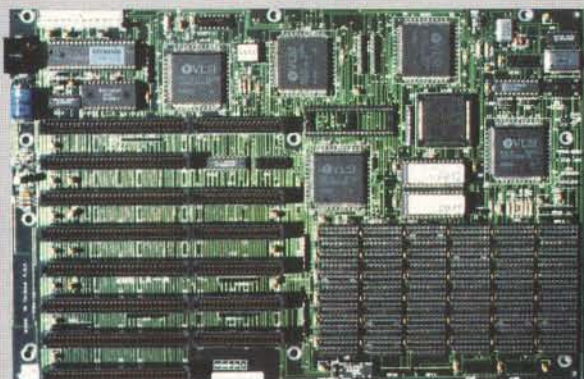

JE3005 8/12MHz AT Compatible Motherboard .. **\$329.95**

IBM AT Compatible 16MHz 80286 NEAT Motherboard

- Expandable to 1MB RAM using 256K DRAM chips or 4MB using 1MB DRAM chips☆
- Additional 1MB with 256K DRAM SIPs or 4MB with 1MB DRAM SIPs for a total of 8MB☆
- 8/12 or 8/16MHz hardware or keyboard selectable
- Front panel LED indicators supported
- Six 16-bit and two 8-bit expansion bus slots
- AMI BIOS ROMs included
- Supports all NEAT functions including shadow RAM, EMS 4.0, RAM re-mapping, selectable wait states, etc.
- 80287-10 Math Co-processor capability☆
- Norton SI rating of 15.6
- Size: 13" x 8.5"
- Weight: 2.25 lbs.

One Year Warranty! Latest Technology!

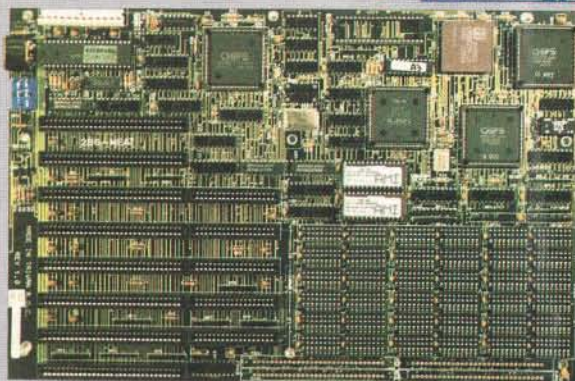

JE3010 8/12/16MHz AT Compatible Motherboard **\$499.95**

IBM PC/XT Compatible TURBO 8MHz Motherboard

- Expandable to 640K RAM using 4164 and 41256, 150ns chips☆
- 4.77 or 8MHz hardware or keyboard selectable operation
- Front panel LED indicators supported
- Eight expansion bus slots
- AMI BIOS ROMs included
- 8087-2 Math Co-processor capability☆
- Performs at an average speed of 75% faster than the original IBM PC/XT
- Norton SI rating of 1.7
- Size: 12" x 8.5"
- Weight: 1.75 lbs.

One Year Warranty!

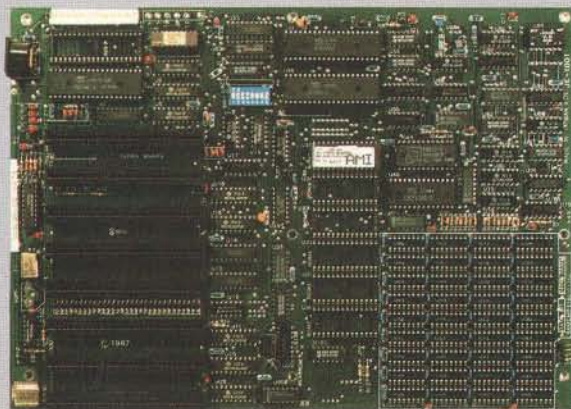

JE1001 4.77/8MHz PC/XT Comp. Motherboard .. **\$89.95**

IBM PC/XT Compatible TURBO 10MHz Motherboard

- Expandable to 640K RAM using 4164, 41256 & 41464 120ns chips☆
- 4.77 or 10MHz hardware or keyboard selectable operation
- Front panel LED indicators supported
- Eight expansion bus slots
- AMI BIOS ROMs included
- 8087-1 Math Co-processor capability☆
- Performs at an average speed of 100% faster than the original IBM PC/XT
- Norton SI rating of 2.0
- Size: 12" x 8.5"
- Weight: 1.75 lbs.

One Year Warranty!

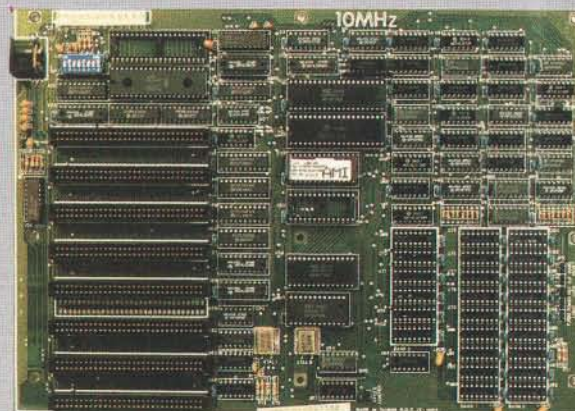

JE1002 4.77/10MHz PC/XT Comp. Motherboard **\$109.95**

See Jameco advertisement on page 438 for RAM and Math Co-processor pricing

• Quality Components • Competitive Pricing • Prompt Delivery • (415) 592-8097 257

Jameco's new IBM PC/XT/AT compatible kits allow you to build your own computer and come with complete step-by-step assembly instructions. **FREE Word Processing and Diagnostic Software Included!**

Please note: JE3008 and JE3013 shipped in 1 box (35 lbs. total) – JE3002 and JE3003 shipped in 2 boxes (50 lbs. total)

IBM AT 12MHz Compatible Kit

- Free! QAPLUS Diagnostic Software Included!
- Free! PC Write Word Processing Software Included!
- 80286 CPU, Optional 80287-8 Math Co-processor Capability
- 512K RAM Included— See descrip. on page 257 for expandability
- 8 or 12MHz Keyboard Switchable Operation
- AMI BIOS ROMs Included
- Save \$144.57



Shown with EGA Option (not included)
JE1059 Monitor and Adapter Card \$519.95
(See page 260)

Part No.	Description	Price
JE3005	8/12MHz Baby AT Motherboard.	\$329.95
	(Zero-K RAM — includes AMI BIOS ROMs)	
JE1016	Enhanced AT Style Keyboard.	69.95
JE1019	Baby AT Flip-Top Case.	69.95
JE1022	5.25" DSHD Disk Drive (Beige Bezel).	109.95
JE1032	200 Watt Power Supply.	89.95
JE1043	360K/720K/1.2MB/1.44MB Floppy Controller.	49.95
41256-100	512K RAM (18 chips).	224.82

Save \$144.57 Regular List \$944.52

JE3008 IBM Compatible AT 12MHz Kit. \$799.95

IBM PC/XT 8MHz Turbo Compatible Kit

- Free! QAPLUS Diagnostic Software Included!
- Free! PC Write Word Processing Software Included!
- 256K RAM Included, Expandable to 640K
- 4.77 or 8MHz Switchable Operation
- AMI BIOS ROM Included
- Save \$128.06



Part No.	Description	Price
JE1001	4.77/8MHz Turbo Motherboard.	\$89.95
	(Zero-K RAM — includes AMI BIOS ROM)	
JE1010	Flip-Top Case.	34.95
JE1015	XT/AT Compatible Keyboard.	59.95
JE1020	5.25" DSDD Disk Drive (Black Bezel).	89.95
JE1030	150 Watt Power Supply.	59.95
JE1040	360K Floppy Controller.	29.95
JE1050	Mono/Graphics Card with Printer Port.	59.95
AMBER	12" Monochrome Amber Monitor.	99.95
41256-150	256K RAM (9 chips).	103.41

Save \$128.06 Regular List \$628.01

JE3002 IBM Compatible PC/XT 8MHz Turbo Kit . . \$499.95

IBM AT 16MHz NEAT Compatible Kit

- Latest Technology!**
- Free! QAPLUS Diagnostic Software Included!
 - Free! PC Write Word Processing Software Included!
 - 80286 CPU, Optional 80287-10 Math Co-processor Capability
 - 2 Megabyte RAM Included, Expandable to 8 Megabyte
 - 8 or 16MHz Keyboard Switchable Operation
 - AMI BIOS ROMs Included
 - Save \$208.85



Shown with JEVGA Option (not included)
JEVGA Monitor and Adapter Card \$649.95
(See page 260)

Part No.	Description	Price
JE3010	12/16MHz NEAT AT Motherboard.	\$499.95
	(Zero-K RAM — includes AMI BIOS ROMs)	
JE1016	Enhanced AT Style Keyboard.	69.95
JE1019	Baby AT Flip-Top Case.	69.95
JE1022	5.25" DSHD Disk Drive (Beige Bezel).	109.95
JE1032	200 Watt Power Supply.	89.95
JE1043	360K/720K/1.2MB/1.44MB Floppy Controller.	49.95
511000P-10	2MB RAM (18 chips).	719.10

Save \$208.85 Regular List \$1608.80

JE3013 IBM Compatible AT 16MHz Kit. \$1399.95

IBM PC/XT 10MHz Turbo Compatible Kit

- Free! QAPLUS Diagnostic Software Included!
- Free! PC Write Word Processing Software Included!
- 640K RAM Included
- 4.77 or 10MHz Switchable Operation
- AMI BIOS ROM Included
- Multi I/O Card
- Save \$192.50



Part No.	Description	Price
JE1002	4.77/10MHz Turbo Motherboard.	\$109.95
	(Zero-K RAM — includes AMI BIOS ROM)	
JE1014	Turbo Flip-Top Case.	69.95
JE1015	XT/AT Compatible Keyboard.	59.95
JE1021	5.25" DSDD Disk Drive (Beige Bezel).	89.95
JE1031	Mini 150 Watt Power Supply.	69.95
JE1071	Multi I/O with Controller and Graphics.	119.95
AMBER	12" Monochrome Amber Monitor.	99.95
4164-120	Parity RAM (2 chips).	5.90
41256-120	512K RAM (18 chips).	215.10
41464-12	128K RAM (4 chips).	51.80

Save \$192.50 Regular List \$892.45

JE3003 IBM Compatible PC/XT 10MHz Turbo Kit \$699.95

IBM PC/XT Compatible Flip-Top and Slide Cases

New Slide Version Available!

- Metal housing and chassis • Anti-static coated plastic face plate
- Flip-up/Slide models available
- Back plate set for 8 expansion card slots and power supply mount
- Will hold up to 4 drives • Color: grey • All necessary hardware incl.
- Size: 19.5"W x 16.5"D x 5.75"H
- Weight: 17 lbs.



JE1010 Flip-Top PC/XT Case. . . . \$34.95
JE1011 Slide PC/XT Case. \$39.95

JE1010

Baby PC/XT/AT Flip-Top and Slide Cases

- Metal housing and chassis • Anti-static coated plastic face plate • Flip-top/slide models available
- Back plate with 8 expansion slots and power supply mount • Switches on front for Turbo mode and Reset • Indicator lights for Power, Turbo mode, Hard disk operation • Keyboard lock with 2-key set • Will hold up to one hard and two floppy drives • All necessary hardware is included • Color: Beige



- Size (JE1014): 14.5"W x 17"D x 6.75"H
- Weight: 17 lbs.
- Size (JE1018/JE1019): 17.125"W x 17"D x 6.5"H • Weight: 21 lbs.

JE1014 Flip-Top Baby XT Turbo Case **\$69.95**
JE1018 Slide Baby AT Case. **\$69.95**
JE1019 Flip-Top Baby AT Case. . . . **\$69.95**

JE1019

IBM PC/XT Compatible 150W Power Supplies

- +5VDC @ 15A**
- 5VDC @ 0.5A**
- +12VDC @ 5.5A**
- 12VDC @ 0.5A**

Reduced Pricing!

- Input: 90VAC-130VAC @ 47-63Hz (110/220V switchable) • Output: +5V @ 15A, -5V @ 0.5A, +12V @ 5.5A, -12V @ 0.5A • Plug compatible connectors • Built-in fan • Size (JE1030): 5.5"W x 9.5"D x 4.625"H, Wt.: 6 lbs. • Size (JE1031): 6.25"W x 6"D x 6"H, Wt.: 5 lbs. • Spec. included



JE1030 PC/XT. **\$59.95**
JE1031 Baby PC/XT. . . **\$69.95**

JE1030

IBM AT Compatible 200W Power Supply

- +5VDC @ 20A**
- 5VDC @ 0.5A**
- +12VDC @ 8A**
- 12VDC @ 0.5A**

- Input: 90VAC-130VAC @ 47-400Hz (110/220V switchable) • Output: +5V @ 20A, -5V @ 0.5A, +12V @ 8A, -12V @ 0.5A • Plug compatible connectors • Built-in fan • Size: 6.5"L x 5.88"W x 6"H • Weight: 6 lbs. • Spec. included



JE1032. **\$89.95**

Floppy Disk Drive Controller Card for IBM PC/XT and Compatible Computers

- Run up to four 360KB disk drives • Includes cable for two internal drives • DC37S connector allows for an additional two external drives (external cable not included) • Complete with manual



JE1040. **\$29.95**

360KB/720KB/1.2MB/1.44MB Floppy Disk Drive Controller Cards for IBM PC/XT/AT and Compatible Computers

- The JE1043 allows connection of one or two 360KB, 720KB, 1.2MB or 1.44MB floppy disk drives • The JE1049 allows connection of up to four 360KB, 720KB, 1.2MB or 1.44MB floppy disk drives • The JE1049 comes with a DC37S connector allowing two external drives to be connected (external cable not included) • Both units include cable for two internal disk drives and manual



JE1043 2-Drive Controller. **\$49.95**
JE1049 4-Drive Controller. **\$59.95**

JE1043

Expansion Memory Half-Card for IBM PC/XT and Compatible Computers

- Expands your system to the maximum 640K (zero-K on-board) • Accepts either 64K memory chips (4164) or 256K chips (41256) • Eight possible memory configurations ranging from 64K to 576K • Fits any slot (except slot 8 on IBM XT) • Manual included



JE1080. **\$49.95**

2Mbyte Memory Expansion Card for IBM AT and Compatible Computers

- 2Mbyte (zero-K on board) memory expansion card for the IBM AT or compatible computers • Utilizes (72) 41256-120ns chips for the full memory capacity of 2Mbytes • Offers conventional, expanded and extended memory capabilities • Features auto-parity check • EMS compatible driver • RAM disk and Print Spooler software included • Manual included

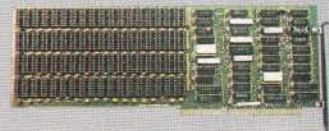

JE1081. **\$119.95**

IBM PC/XT/AT Compatible Keyboards



- 84-key • AT style layout • Tactile touch keyswitches • Switch selectable between PC/XT or AT • Illuminated LED indicators for Num Lock, Caps Lock and Scroll Lock • Low profile design • Manual included • Color: Beige
- Size: 19.5"W x 7.5"D x 1.33"H • Weight: 4.6 lbs.

JE1015. **\$59.95**



- 101-key • Enhanced keyboard layout • Tactile touch keyswitches • 12 function keys • Illuminated LED indicators for Num Lock, Caps Lock & Scroll Lock • Separate cursor pad • Low profile design • Automatically switches between PC/XT or AT • Manual included • Color: Beige
- Size: 19"W x 8"D x 1.33"H • Wt: 4.6 lbs.

JE1016. **\$79.95 \$69.95**

• Quality Components • Competitive Pricing • Prompt Delivery • (415) 592-8097

Casper 14" EGA and Multiscan Monitors for IBM PC/XT/AT and Compatible Computers

The TM5154 EGA Monitor and TM5155 Multiscan Monitor are ideal for text as well as CAD and other graphics applications. Both monitors come with a tilt/swivel base, manual and cable.

TM5154 (Specs.): • EGA/CGA compatibility • Input: DB9 (TTL) • Scanning freq.: 15.75kHz to 21.85kHz • Resolution: 720 x 350 (max.) • Bandwidth: 25MHz • Size: 15"W x 14.25"D x 14"H • Weight: 35 lbs.

- TM5154** 14" CGA/EGA Monitor. **\$399.95**
- JE1055** EGA Card (Used with TM5154 and TM5155 Monitors) . . . **\$159.95**
- JE1059** TM5154 and JE1055 **SAVE \$40.00.** **\$519.95**

TM5155 (Specs.): • MDA, CGA, EGA, PGC, VGA compatibility • DB9-pin male connector for TTL and DB15-pin adapter for analog input • Switch on back for TTL or Analog input • Scanning frequencies: 15.5kHz to 40kHz • Max. resolution: 800 x 600 • Bandwidth: 40MHz • Size: 15"W x 15"D x 13.5"H • Weight: 35 lbs.

- TM5155** 14" MDA/CGA/EGA/PGC/VGA Monitor. **\$549.95**



TM5154

NEW! 13" VGA Monitor and Adapter Card

VGA Compatibility at EGA Prices!

This VGA package offers a clear 13" color display with the ability to display up to 256 colors simultaneously from a palette of 262,144. The fully compatible VGA card from ATI supports all VGA modes.

Features: • 13" Color Screen • Max. resolution: 800 x 560 • Bandwidth: 17MHz • 256 colors from a palette of 262,144 • Upgrades any PC/XT, AT or hardware compatible to VGA graphics • Softsense Automatic Mode switching compatibility with VGA, EGA, CGA, MDA, HGA • Anti-reflective coated, non-interlaced, flicker-free screen • Size (monitor only): 15"W x 15.5"D x 11.25"H • Weight: 30 lbs.

- JEVGA** VGA Color Monitor and VGA Card. **\$649.95**



NEW! RIX EGA Paint 2005

This powerful EGA Paint program gives you the following and much more at a reasonable price: • Pop-up menus • Zoom image windows • Image library • Color mixing capability • Small function allows you to save your image in 50% to 90% less disk space • Text editing with 9 to 72 point and 34 contemporary fonts • Line smoothing capability • Capture capability • Mouse or keyboard operation • Print capability for almost any dot-matrix, color, or laser printer available • Slide show capability allows creation of presentations • Plus much, much more!

- EGAP** EGA Paint 2005. **\$89.95**



12" Amber Monochrome Monitor for IBM PC/XT/AT and Compatible Computers

• Input: DB9 (TTL) • Bandwidth: 20MHz • Horizontal scanning frequency: 18.432kHz • Character display: 80 characters x 25 rows • Weight: 19 lbs. • Size: 12.5"W x 12"D x 12"H • Compatible w/JE1050, JE1055 and JE1071 (see below) • Cable and manual included



- AMBER.** **\$99.95**

CTX 14" RGB Color Monitor for IBM PC/XT/AT and Compatible Computers

• Input: DB9 (RGB) • Horizontal scanning frequency: 14.5kHz to 17.8kHz • Video bandwidth: 18MHz • Display area: 13.1" diagonally • Resolution: 640 x 200 • Controls: (Front) Brightness, Contrast, V-Hold; (Rear) H-Phase, H-Hold, V-Lin., V-Size • 70W • Switch for Amber, Green or Color Screen • Size: 14.6"W x 15.5"D x 13.6"H • Weight: 27 lbs. • Compatible with JE1052 and the JE1055 (see below) • Cable and manual included



- CTX2410.** **\$279.95**



IBM PC/XT/AT Compatible Display Cards

1-Year Warranty!

Monochrome Graphics Adapter for IBM PC/XT/AT

Compatible with IBM Monochrome and Hercules Graphics Standards

The JE1050 is a monochrome graphics card with parallel printer port and features the following: • Text mode: 80 x 25; Graphics mode: 720 x 348 • Compact half-card • Parallel printer interface with transfer rate up to 1000 characters per second • Manual included

- JE1050.** **\$59.95**

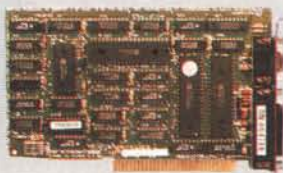

Color Graphics Adapter for IBM PC/XT/AT

Compatible with IBM Color Graphics Standard

The JE1052 is a color graphics adapter card capable of operating with either IBM RGB or composite monochrome monitors and features the following: • Parallel printer port • Text modes: 40 x 25 or 80 x 25; Graphic modes: 320 x 200 or 640 x 200 • Light pen interface • Includes composite video monitor adapter • Manual included

- JE1052.** **\$49.95**



Enhanced Graphics Adapter for IBM PC/XT/AT

Compatible with IBM Enhanced Graphics Standard

The JE1055 is an IBM EGA/CGA/MDA/HGA compatible card featuring the following: • Text mode: 80 x 25; Graphics mode: 720 x 348 • Reserved video jacks and feature connectors • Light pen interface • 256K Video RAM • Dip-switch on back of card allows changing of switch settings without opening case • Displays 16 out of 64 colors • Manual included

- JE1055.** **\$159.95**

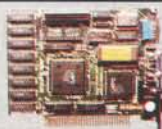

Multi I/O with Controller and Graphics for IBM PC/XT

Compatible with IBM Monochrome and Hercules Graphics Standards

The JE1071 is a multi I/O card with six add-on functions, uses only one slot and features the following: • Text mode: 80x25; Graphics mode: 720x348 • One RS232C serial communication port (expandable to two — see page 263 for 2nd Serial Port Kit) selectable for COM1 thru COM4 • Game port • Real-time clock/calendar with replaceable battery back-up • 5.25" floppy disk drive controller capable of handling up to two 360K drives • Parallel printer port • Print spooler software • Manual and cables included

- JE1071.** **\$119.95**



NEW!

3.5" AND 5.25" FLOPPY DISK DRIVES

NEW!

**Mitsubishi 720KB
3.5" Internal
Floppy Disk Drive
for the IBM PC/XT/AT
and Compatible Computers**

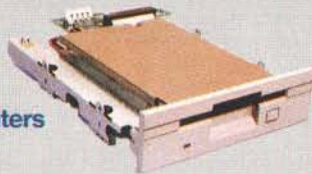

Includes 5.25" mounting frame for IBM PC/XT/AT and compatible computers. May require DOS 3.2 or higher for operation. The MF353B is compatible with the JE1043 and JE1049 Interface Cards (see page 259).

Specifications: • 720KB formatted storage • Double-sided, double-density • 135TPI • 160 tracks • Rotation speed: 300rpm • Track to track access time: 3ms • Full installation documentation included • Size: 5.75"W x 8.25"D x 1.75"H • Weight: 1.7 lbs.

MF353B..... \$109.95

**Mitsubishi 1.44MB
3.5" Internal
Floppy Disk Drive
for the IBM PC/XT/AT
and Compatible Computers**

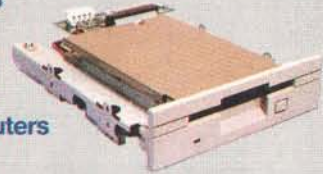

Includes 5.25" mounting frame for IBM PC/XT/AT and compatible computers. May require DOS 3.3 for operation. Also compatible with 720KB floppy disks. The MF355B is compatible with the JE1043 and JE1049 Interface Cards (see page 259).

Specifications: • 1.44MB formatted storage • Double-sided, high density • 135TPI • 160 tracks • Rotation speed: 300rpm • Track to track access time: 3ms • Full installation documentation included • Size: 5.75"W x 8.25"D x 1.75"H • Weight: 1.7 lbs.

MF355B..... \$129.95

**Jameco 5.25" Half
Height Drives
for IBM PC/XT/AT
and Compatible Computers**



JE1020

JE1020 — IBM PC/XT/AT Compatible • 360KB, double-sided, double density • 48 TPI • 80 tracks • Spec included • Color (bezel): Black • Size: 5.75"W x 8.13"D x 1.63"H • Weight: 2.7 lbs.

JE1020..... \$89.95

JE1021 — IBM PC/XT/AT Compat. • Same specs as JE1020 except comes with beige color bezel.

JE1021..... \$89.95

JE1022 — IBM AT Compatible (Also compatible with IBM PC/XT when used w/JE1043 and JE1049, see page 259) • 1.2MB, double-sided, high density • 96 TPI • 160 tracks • Spec included • Color (bezel): Beige • Size: 5.75"W x 8.13"D x 1.63"H • Weight: 2.7 lbs.

JE1022..... \$109.95

**TEAC 5.25" Half
Height Drives
for IBM PC/XT/AT
and Compatible Computers**



FD55B

FD55B — IBM PC/XT/AT Compatible • 360KB, double-sided, double density • 48 TPI • 80 tracks • Spec included • Color (bezel): Black • Size: 5.75"W x 8.13"D x 1.63"H • Weight: 3.3 lbs.

FD55B..... \$99.95

FD55GFV — IBM AT Compatible (Also compatible with IBM PC/XT when used with JE1043 and JE1049, see page 259) • 1.2MB, double-sided, high density • 96 TPI • 160 tracks • Spec included • Color (bezel): Black • Size: 5.75"W x 8.13"D x 1.63"H • Weight: 3.3 lbs.

FD55GFV..... \$119.95

**Tandon 5.25" Full
Height Drive
for IBM PC/XT
and Compatible Computers**

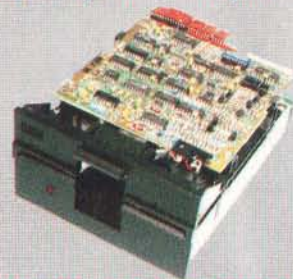

IBM PC/XT Compatible!

TM100-2 — IBM PC/XT Compatible • 360KB, double-sided, double density • Full height drive • 48 TPI • 80 tracks (40 tracks per side) • Rotation speed: 300rpm • Track to track access time: 5ms • Documentation included • Color (bezel): Black • Size: 5.75"W x 8.00"D x 3.38"H • Weight: 5 lbs.

***TM100-2..... \$99.95**

The JE1020, JE1021, JE1022, FD55B, FD55GFV and TM100-2 DO NOT include case, power supply, cables, mounting hardware or manuals. All disk drive manuals are \$5.00.

See page 66 for Diskettes and Accessories



FLOPPY DISK DRIVE ENCLOSURES



3.5" Floppy Disk Drive Enclosure

**Houses One Half-Height
3.5" Disk Drive**

(Horizontal Mount) • Power: +12V @ 1.2A, +5V @ 1.0A • Textured beige paint • Slot for data cable • Complete with power supply, switch, power cord, fuse holder and connectors • Size: 5.87"W x 2.25"H x 11.5"D • Weight: 6 lbs.

DDE3HH..... \$59.95



5.25" Floppy Disk Drive Enclosure

**Houses One Full-Height
5.25" Disk Drive**

(Horizontal Mount) • Power: +5V @ 1.0A, +12V @ 1.2A • Textured beige paint • Slot for data cable • Unit comes complete with power supply, switch, power cord, fuse holder and connectors • Size: 5.87"W x 3.25"H x 11.5"D • Weight: 6 lbs.

DDE1FH..... \$59.95



Dual 5.25" Floppy Disk Drive Enclosure

**Houses Two Half-Height
5.25" Disk Drives**

(Vertical Mount) • Power: 2 x +5V @ 1.0A*, 2 x +12V @ 1.2A* (*not simultaneously) • Textured beige paint • Data cable strain relief for operation safety • Complete with power supply, switch, power cord, fuse holder and connectors • Size: 3.5"W x 5.78"-6.19"H (slope) x 12.87" (bottom) — 13.13"D (top) • Weight: 6.5 lbs.

DDE2HH..... \$69.95



5.25" Floppy Disk Drive Enclosure

**Houses One Half-Height
5.25" Disk Drive**

(Horizontal Mount) • Power: +12V @ 1.2A, +5V @ 1.0A • Textured beige paint • Slot for data cable • Complete with power supply, switch, power cord, fuse holder and connectors • Size: 5.87"W x 2.25"H x 11.5"D • Weight: 6 lbs.

DDE1HH..... \$59.95



*CLOSE-OUT PRICING — PART NUMBER WILL BE DISCONTINUED WHEN STOCK IS DEPLETED!

• Quality Components • Competitive Pricing • Prompt Delivery • (415) 592-8097

261



20, 30, 40 and 60 Megabyte Half-Height Hard Disk Drives for the IBM PC/XT/AT and Compatible Computers

Seagate Hard Disk Drives provide the IBM PC/XT/AT or compatible computers with 20, 30, 40 or 60 Megabytes of formatted capacity in a shock resistant, half-height package. These drives are easily installed and ideal for applications ranging from rugged industrial use to quiet office and home environments. High reliability is assured through the use of LSI and a single circuit board. The drives may be purchased with or without controller cards. Controller cards are capable of controlling two hard drives. Cables provided for connecting one hard drive only. 90-Day Warranty. Documentation included.

ST225 (20 Megabyte): • Available for PC/XT or AT • Track to track access time: 20 msec. max. • Average access time: 65 msec. • Data transfer rate: 5.0 Megabits/sec. • Tracks: 2,460 • Bytes per track (formatted): 8,704 • Read/Write Heads: 4 • Cylinders: 615 • Size: 5.75"W x 8"D x 1.63"H • Weight: 5 lbs.

Part No.	Description	Price
ST225	20MB Hard Disk Drive Only for IBM PC/XT/AT and compatibles (MFM Controller needed).	\$224.95
ST225XT	20MB Hard Disk Drive, MFM Controller and Cables for IBM PC/XT and compatibles.	\$269.95
ST225AT	20MB Hard Disk Drive, MFM Controller, Software and Cables for IBM AT and compatibles.	\$339.95



Seagate ST225XT 20MB Hard Disk Drive Kit

ST238 (30 Megabyte): • Available for PC/XT or AT • Track to track access time: 20 msec. max. • Average access time: 65 msec. • Data transfer rate: 7.5 Megabits/sec. • Tracks: 2,460 • Bytes per track (formatted): 13,312 • Read/Write Heads: 4 • Cylinders: 615 • Size: 5.75"W x 8"D x 1.63"H • Weight: 5 lbs.

Part No.	Description	Price
ST238	30MB Hard Disk Drive Only for IBM PC/XT/AT and compatibles (RLL Controller needed for operation).	\$249.95
ST238XT	30MB Hard Disk Drive, RLL Controller and Cables for IBM PC/XT and compatibles.	\$299.95
ST238AT	30MB Hard Disk Drive, RLL Controller and Cables for IBM AT and compatibles.	\$389.95



Seagate ST238XT 30MB Hard Disk Drive Kit

ST251 (40 Megabyte): • Available for PC/XT or AT • Track to track access time: 8 msec. max. • Average access time: 40 msec. • Data transfer rate: 5.0 Megabits/sec. • Tracks: 4,920 • Bytes per track (formatted): 8,704 • Read/Write Heads: 6 • Cylinders: 820 • Size: 5.77"W x 8"D x 1.63"H • Weight: 5 lbs.

Part No.	Description	Price
ST251	40MB Hard Disk Drive and Software Only for IBM PC/XT/AT and compatibles (MFM controller needed).	\$429.95
ST251XT	40MB Hard Disk Drive, MFM Controller and Cables for IBM PC/XT and compatibles.	\$469.95
ST251AT	40MB Hard Disk Drive, MFM Controller, Software and Cables for IBM AT and compatibles.	\$539.95
ST251-1	NEW! Fast 28ms 40MB Hard Disk Drive and Software Only for IBM PC/XT/AT and compatibles (MFM controller needed) ..	\$499.95



Seagate ST251AT 40MB Hard Disk Drive Kit

ST277 (60 Megabyte): • Available for PC/XT or AT • Track to track access time: 8 msec. max. • Average access time: 40msec. • Data transfer rate: 7.5 Megabits/sec. • Tracks: 4,920 • Bytes per track (formatted): 13,312 • Read/Write Heads: 6 • Cylinders: 820 • Size: 5.77"W x 8"D x 1.63"H • Weight: 5 lbs.

Part No.	Description	Price
ST277	60MB Hard Disk Drive & Software Only for IBM PC/XT/AT & compatibles (RLL Controller needed for operation).	\$499.95
ST277XT	60MB Hard Disk Drive, RLL Controller and Cables for IBM PC/XT and compatibles.	\$549.95
ST277AT	60MB Hard Disk Drive, RLL Controller and Cables for IBM AT and compatibles.	\$639.95



Seagate ST277AT 60MB Hard Disk Drive Kit

See Next Page for Hard Disk Drive Controller Cards

RS232 Half Card for IBM PC/XT/AT and Compatible Computers

• Fits the difficult to use half card slot or any long slot • RS232 card comes with one ready-to-go serial port • Expandable to 2 ports by user (parts for expansion not included — see below for 2nd Serial Port Kit) • Selectable for COM1 thru COM4 • The user is able to select addresses for ports A and B as well as interrupt requests • Manual included



JE1061

JE1061 RS232 Card for XT. **\$29.95**
JE1062 RS232 Card for AT. **\$34.95**

Input/Output Cards for IBM PC/XT/AT and Compatible Computers

Four Functions on One Card!

The JE1060 and JE1065 Input/Output cards for the IBM PC/XT/AT feature the following:
• Parallel printer port • RS232C serial communication port (expandable to two by user — see below for 2nd Serial Port Kit) • Selectable for COM1 thru COM4 • Ability to change interrupt requests on all ports • Game port • Cables and manual included • JE1060 (Only): Real-time clock/calendar with replaceable battery back-up and print spooler software included



JE1060

JE1060 I/O Card for XT. **\$59.95**
JE1065 I/O Card for AT. **\$59.95**

Multifunction Card for IBM PC/XT and Compatible Computers



Five Functions on One Card!

The JE1078 features: • Add up to 384K (zero-K on-board) using (54) 4164's • Parallel printer port • RAM disk and print spooler software • One RS232C serial communication port • Selectable for COM1 or COM2 • Game port • Real-time clock/calendar with replaceable battery back-up • 4.77MHz operation • Manual and cables included

JE1078. **\$69.95**

Multi I/O with Floppy Controller for IBM PC/XT/AT and Compatible Computers



JE1079

The JE1077/1079 are multi I/O cards with up to 5 additional features • One RS232C serial communication port (expandable to two — see below for 2nd Serial Port Kit) • Selectable for COM1 thru COM4 • Game port • Real-time clock/calendar (JE1079 only) • 3.5"/5.25" floppy disk drive controller capable of handling up to two 360K, 720K, 1.2MB or 1.44MB drives • Parallel printer port • Print spooler software • Manual and cables included

JE1079 Multi I/O and Controller for XT. **\$79.95**
JE1077 Multi I/O and Controller for AT. **\$79.95**

3Mbyte Memory Expansion Card and Multifunction Card for IBM AT and Compatible Computers



The JE1082 is a 3MB Multifunction Memory Expansion card for the IBM AT and compatible computers. Expandable to 3MB (zero-K on-board) with (108) 41256-120 chips. Can be used as expanded (up to 2MB) or extended memory (up to 3MB). Also included is one Serial port (selectable for COM1 thru COM4) expandable to two (see right for 2nd Serial Port Kit), parallel port and game port. Piggyback board for expansion to 3MB, RAM disk/Print Spooler Software and manual included.

JE1082. **\$169.95**

Second Serial Port Kits

for JE1060, JE1061, JE1062, JE1065, JE1071, JE1077, JE1079 and JE1082

• Kits contain all components and instructions for adding a 2nd Serial Port to the above cards • The new SSP4 is a high-speed version for the JE1062, JE1065, JE1077 and JE1082 — Some soldering required.



SSP3 2nd Serial Port Kit for JE1060, JE1061, JE1071 & JE1079. **\$9.95**
SSP4 Hi-Speed 2nd Serial Port Kit for JE1062, JE1065, JE1077 & JE1082 **\$14.95**

Hard Disk/Floppy Controller for IBM PC/XT and Compatible Computers



The JE1044 is an 8-bit floppy and MFM hard disk controller for the IBM PC/XT and compatible computers. The JE1044 will allow connection of up to two hard disks and two floppy 360KB drives. Cables are included to allow connection of one hard disk and two floppy disk drives. To connect a second hard disk drive, an additional cable will be required.

JE1044. **\$129.95**

Hard Disk/Floppy Controller for IBM AT and Compatible Computers



The JE1045 is a 16-bit floppy and MFM hard disk controller for the IBM AT and compatible computers. The JE1045 will allow connection of up to two hard disk drives and any combination of two floppy disk drives (360KB, 720KB, 1.2MB and 1.44MB). Cables are included to allow connection of one hard disk and two floppy disk drives. To connect a second hard disk drive, an additional cable will be required.

JE1045. **\$149.95**

RLL Hard Disk Controller Cards for IBM PC/XT/AT and Compatible Computers

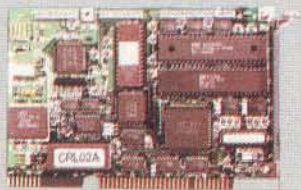

JE1042

The JE1042 is an 8-bit RLL hard disk controller card for the IBM PC/XT and compatible computers. The JE1042 should be used with hard disks designed for RLL formatting such as the Seagate 30MB ST238 and 60MB ST277. Cables and documentation included.

JE1042 RLL PC/XT Hard Disk Controller Card. **\$99.95**

The JE1047 is a 16-bit RLL hard disk controller for the IBM AT and compatible computers. The JE1047 should be used with hard disks designed for RLL formatting such as the Seagate 30MB ST238 and 60MB ST277. Cables and documentation included.

JE1047 RLL AT Hard Disk Controller Card. **\$189.95**

MFM Hard Disk Controller Cards for IBM PC/XT/AT and Compatible Computers

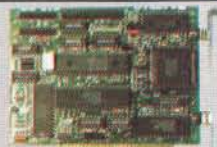

JE1041

The JE1041 is an 8-bit MFM hard disk controller card for the IBM PC/XT and compatible computers. The JE1041 can be used with many types of hard disk drives including the Seagate 20MB ST225 and 40MB ST251/ST251-1. Cables and documentation included.

JE1041 MFM PC/XT Hard Disk Controller Card. **\$79.95**

The JE1046 is a 16-bit MFM hard disk controller for the IBM AT and compatible computers. The JE1046 can be used with many hard disk drives including the Seagate 20MB ST225 and 40MB ST251/ST251-1. Cables and documentation included.

JE1046 MFM AT Hard Disk Controller Card. **\$129.95**

• Quality Components • Competitive Pricing • Prompt Delivery • (415) 592-8097

Logitech M8 Mouse for IBM PC/XT/AT and Compatible Computers



AD925 (not included)

M8

The LOGITECH M8 mouse features opto-mechanical technology at a competitive price. This new two-button mouse requires one male DB25-pin serial port and comes with a female DB25 cable assembly. A DB25 to DB9 adapter (AD925, see below) may be needed if the serial port you plan to use has a male DB9 connector. The mouse comes standard with a six foot cord and features 200 dpi resolution. • Color: Light Gray • Size: 3.8"L x 2.7"W x 1.06"H • One-Year Warranty

Part No.	Description	1-9	10-99
M8	M8 Mouse with Driver Software.	\$49.95	\$44.95
AD925	DB25-pin male to DB9-pin female adapter for Serial applications.	\$4.95	\$3.95

Logitech HiREZ Bus Mouse for IBM PC/XT/AT & PS/2 (Model 25, 30) and Compatible Computers

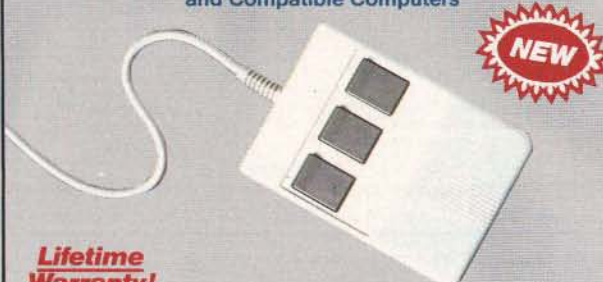

Lifetime Warranty!

The new LOGITECH High Resolution Mouse is the only mouse designed expressly for today's new generation of high resolution displays, such as EGA, super EGA and VGA. The mouse is ideal for desktop publishing as well as CAD applications. With 320 dots per inch (dpi) resolution (compared with 100 or 200 dpi mice), the LOGITECH HiREZ covers the same area on your screen, but uses 62% less desk space to do it. This saves you valuable desk space, and effort. Mouse maneuvers that used to require a sweep of the hand are now reduced to a flick of the wrist. Includes Plus Package software with mouse drivers, text editor, menu building and point-click software (Lotus 1-2-3) • Size: 3.8"L x 2.7"W x 1.06"H • Color: Light Gray • Lifetime Warranty

Part No.	Description	1-9	10-99
HiREZ	High Resolution Mouse, Bus Board and Plus Package Software.	\$99.95	\$94.95

Logitech Desktop Publishing Mouse and Software

for IBM PC/XT/AT & PS/2 (Model 30) and Compatible Computers

This sophisticated yet easy to use desktop publishing package includes the Logitech Serial (C7PLUS mouse - right) or BUS Mouse (right), PLUS Package Software and Publisher desktop publishing software. The package is the complete solution for people who want to produce great looking, attention-getting documents without having to master a lot of complex commands and typographical jargon. It's easy to learn, fast to use, and it gets you the results you need right now. • Lifetime Warranty: C7PLUS and BUS Mouse only



LPP7



Page Layout Made Easy . . . You don't have to be a graphic designer to get professional-quality results. Create and edit text right on the page. The package offers design templates, automatic layout in 1-4 columns, automatic flow of text around graphics, and vertical and horizontal rulers to guide you.

Typography Made Easy . . . Select from over 61 fonts representing 14 typefaces, in sizes suitable for headlines, subheads and text.

Graphics Made Easy . . . using our ClipArt. You can shrink or expand your graphic images, modify, rotate or copy them to fit the area you desire.

LPP7	C7PLUS Mouse & Publisher Package Software.	\$129.95
LPBUS	BUS Mouse and Publisher Package Software.	\$129.95



Logitech Serial and Bus Mouse

for IBM PC/XT/AT & PS/2 (Model 25, 30) and Compatible Computers

The LOGIMOUSE C7 features opto-mechanical technology, programmable baud rate up to 9600 baud, and excellent tracking. LOGIMOUSE is fully compatible with all mouse-based application programs (e.g. AutoCad, MS Windows, etc.). Logitech PLUS package software features drivers, LOGIMENU (Programmable Pop-up Menu System), CLICK (sets mouse to predefined settings), POINT-AND-CLICK SHELL (for Lotus 1-2-3), and POINT EDITOR (Mouse Based Program Editor). The C7PLUS requires one serial port. • Size: 3.8"L x 2.7"W x 1.06"H • Color: Light gray • Lifetime Warranty



BUS

PC/XT/AT & PS/2 (Model 25, 30) Compatible!

Part No.	Description	1-9	10-99
C7PLUS	C7 Mouse and Logitech PLUS Package Software.	\$79.95	\$74.95

BUS MOUSE frees your serial port. The Bus Board installs easily in a half slot in your computer and leaves your system's serial port free for other peripherals.

Part No.	Description	1-9	10-99
BUS	Logitech Mouse, Bus Board and Logitech PLUS Package Software.	\$79.95	\$74.95

NEW!

Mouse Pad

Prevents Dirt Contamination!

Cleans, protects and prevents wear on your mouse's roller ball. Sensitive, accurate and prevents dirt contamination. Tough non-skid neoprene backing with smooth gliding anti-static plastic coating on top surface. Size: 11"L x 8.5"W

MP	Mouse Pad.	\$5.95
----	--------------------	--------



Logitech ScanMan Hand-Held Scanner for IBM PC/XT/AT & PS/2 and Compatible Computers

The Logitech ScanMan Portable Scanner makes adding graphic images to computer documents affordable!



The ScanMan offers the largest handheld scanning window available — a full four inches at 200 dpi resolution (most scanners only offer 2.5 inches). Graphics are scanned directly to the powerful ScanWare™ Graphics editor where a full range of paint utilities and tools are available for editing the scanned image.

ScanMan combines power and flexibility in one neat package. Scan directly to the powerful graphics editor, directly to a file, or to an MS Windows™ clipboard using the Logitech WinScan™ utility.

You can scan photographs, newspaper and magazine articles, books, drawings, logos and business cards. Scanned images may be stored and used in many of the most popular applications, including: LOGITECH Publisher, Aldus PageMaker™, Ventura Publisher™, PFS: First Publisher™, ZSoft PC Paintbrush™ and many, many more. Includes driver controller card and cable. • Size: 5.25"W x 3.5"D x 1.25"H • Color: Light Gray • One-Year Warranty

SCAN	ScanMan Hand-Held Scanner, Software and Driver Board.	\$199.95
------	---	----------



NEW!

MODEMS

SALE!



2400/1200/300 Baud Internal Modems for IBM PC/XT/AT and Compatible Computers

Internal Card Frees Your Serial Port! • Hayes command compatible • Bell 103/212A compatible • Auto-dial and auto-answer • Tone or pulse dialing capability • Call progress detection • Easy access DIP switch • Supports COM1, COM2, COM3 and COM4 • Two modular phone jacks • Built-in speaker with adjustable volume control • FCC approved • Includes MaxiMite communication software by Mycroft Labs • One-year warranty



1200H

**Includes
MaxiMite Software!**

1200H	1200/300 Baud Internal Modem (½ Card)	\$69.95
2400S	2400/1200/300 Baud Internal Modem (¾ Card)	\$139.95 \$129.95

DATATRONICS 1200/300 Baud Pocket Modem for IBM PC/XT/AT and Compatible Computers

Also compatible with other computer systems that have an RS232 port.



This shirt pocket-sized, lightweight miniature modem is perfect for the computer user on the move. Features the following:
• Hayes command compatible • Bell 103/212A compatible • LED status lights for: Battery, High Speed and Carrier Detect • Auto-dial and auto-answer • Tone, pulse or adaptive dialing • Call progress detection • On-board speaker • Two modular telephone jacks • Uses standard 9VDC battery or 9VDC transformer (not included) for power • Includes: 9V battery, carrying case, telephone connector cable and manual • Size: 4"L x 2.375"W x .875"H • Weight: 0.25 lb. • One-year warranty

1200P	1200/300 Baud Pocket Modem.	\$109.95 \$99.95
--------------	-------------------------------------	------------------------------------

DATATRONICS 2400/1200/300 Baud External Modems for IBM PC/XT/AT & Compatible Computers

Also compatible with other computer systems which have an RS232 port • Hayes command compatible • Bell 103/212A compatible • Auto-dial and auto-answer • Tone, pulse or adaptive dialing capability • Call progress detection • Two modular phone jacks • Built-in speaker with adjustable volume control • FCC approved • Includes MaxiMite communication software • Size: 5.75"W x 10"D x 1.6"H • Weight: 3.25 lbs. • One-year warranty



2400E

Part No.	Description	Price
1200C	1200/300 Baud External Modem.	\$119.95 \$ 99.95
2400E	2400/1200/300 Baud External Modem . . .	\$179.95 \$169.95

ZOOM 300 Baud Modems

for Apple II, II+
and IIe



ZM300

Two versions available: (NM300) Manual dial, manual answer or (ZM300) Auto-dial, auto-answer • Hayes compatible • Includes call progress monitor, speaker, Zoom Communications Software and manual • Made in the USA • Two year warranty • Also available is the NMS software enhancement for the NM300 and ZM300 which allows Xmodem file transfer, storage, editing and printing of files

Part No.	Description	Price
NM300	300 Baud Manual Dial/Answer Modem (II, II+ and IIe) \$29.95 \$19.95	
ZM300	300 Baud Auto Dial/Answer Modem (II, II+ and IIe) \$49.95 \$49.95	
NMS	Software Enhancement for NM300 and ZM300. \$19.95 \$19.95	

APROTEK 1200/300 Baud External Modem for Commodore C-64 and C-128

Hayes and Commodore
1670 Compatible!

• Plugs directly into the Commodore user port • Runs at either 1200 or 300 baud • Full Hayes compatibility including terminal emulation and file transfer • Auto-dial and auto-answer • Touch tone or rotary dialing capabilities • Seven LED status indicators for send data, off hook, 1200 baud, carrier detect, receive data, auto answer and ready • FCC approved • Includes Multiterm communication software for Commodore 64 and 128 • Size: 4.75"L x 2.75"W x .7"H • Weight: 0.25 lb. • 1-year warranty



MMC	1200/300 Baud External Modem (C64/128).	\$79.95 \$79.95
------------	---	-----------------------------------



COMPUTER POWER PROTECTION



JE1191

Jameco Power Base with 6 Control Switches and 6-Outlet Power Strip

The JE1190 Power Base utilizes solid state line conditioning circuitry and fully shielded sockets to protect your computer from harmful power surges and EMI noise. Each device within your computer system can be turned on or off by individual illuminated rocker switches or the entire system can be turned on by the master switch. The Power Base eliminates the maze of power cords normally found behind most computer systems. • **JE1190 Specifications:** • 5 outlets • 15A, 125VAC, 1875 Watts, 60Hz • Max. spike: 80 joules one time • Energy dissipation: 25 joules repeated, self-restoring • Max. spike volts: 6,000V • Max. spike current: 4,500A • Clamp volts: 175V • Clamping response time: 10ns • Color: Beige • Size: 12"W x 12.75"D x 2.25"H • Weight: 5.25 lbs.



JE1190

The JE1191 Power Strip with built-in circuit breaker gives you continuous spike protection. **JE1191 Specifications:** • Master switch with pilot light • Built-in safety circuit breaker (15 amp) • UL listed • Durable enamel finished housing • Three-prong, 6-foot power cord • Color: Beige • Size: 12"L x 2.25"W x 1.5"H • Weight: 2 lbs.

Part No.	Description	Price
JE1190	Power Base with 6 Control Switches and Surge Protection.	\$29.95 \$29.95
JE1191	Power Strip with 6 Outlets and Circuit Breaker.	\$11.95 \$11.95

See opposite page for tilt/swivel Monitor Base with Power Center

NEW! TrippLite Isobar Command Console Plus

Complete Isobar protection with fingertip control for all your systems' components plus new Modem and FAX protection outlets

• Each outlet offers Isobar surge suppression and filter isolation • Mounts conveniently between your CPU and CRT • Command console provides one main on/off switch and five individual component switches • 6 outlets total • Two New RJ11 receptacles for modem/FAX/telephone line spike protection • Built-in static guard • 15 amps on one receptacle • Color: Beige • Size: 12.5"L x 13.5"W x 2"H • Weight: 8 lbs.

CC16P	Command Console Plus with Modem and FAX Protection.	\$99.95 \$99.95
--------------	---	-----------------------------------

Lifetime Warranty!



• **Quality Components** • **Competitive Pricing** • **Prompt Delivery** • **(415) 592-8097**

- Low static, plastic body – CMOS safe
- Nickel plated clips designed to withstand up to 5,000 insertion cycles
- Breadboard strips easily connect together to form larger working areas
- Screen printed color coordinates make circuit design easier
- Larger models come with heavy duty aluminum backing and grounding posts for long life and durability
- Components are easily interconnected using 20-29 AWG wire (see JE10 and JE11, below)
- The JE31 offers all the advantages of the JE26 plus a wire jumper kit containing 140 assorted wire jumpers

Breadboarding Versatility!

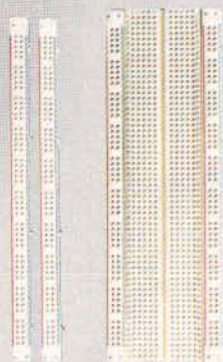

JE20

JE23



JE24

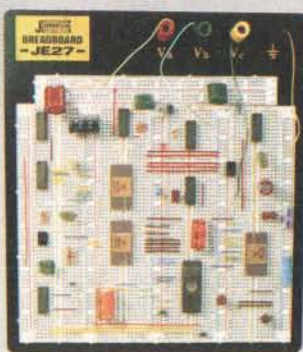

JE27

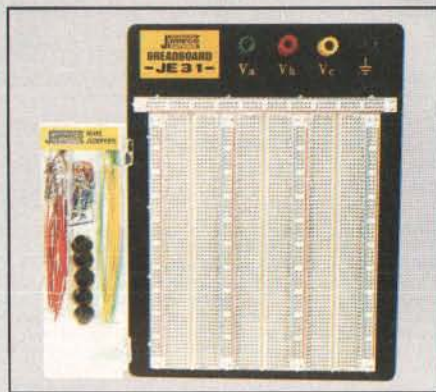

JE31

Part No.	Terminal Strips	Bus Strips	Contact Points	Binding Posts	Jumper Wires	Component Case	Size L x W (Inches)	1-9	10-99
JE20	0	2	200	0	0	0	6½ x ¾	\$ 2.95	\$ 2.49
JE21	1	2	400	0	0	0	3¼ x 2½	\$ 4.95	\$ 4.49
JE22	1	0	630	0	0	0	6½ x 1¾	\$ 5.95	\$ 4.95
JE23	1	2	830	0	0	0	6½ x 2½	\$ 7.95	\$ 6.95
JE24	2	1	1,360	2	0	0	6½ x 3½	\$14.95	\$12.95
JE25	2	4	1,660	3	0	0	6½ x 4¼	\$22.95	\$19.95
JE26	3	5	2,390	4	0	0	6¾ x 5¾	\$27.95	\$24.95
JE27	4	7	3,220	4	0	0	7¼ x 7½	\$37.95	\$34.95
JE31	3	5	2,390	4	140	Stores Wire Jumpers	6¾ x 5¾	\$31.95	\$28.95

JE450 Solderless Prototype Builder

The JE450 Solderless Prototype Builder provides the user with a quick and efficient system for breadboarding electronic circuits without soldering. Configured with 3 power supplies, the JE450 is ideal for IC breadboarding of TTLs, CMOS, ECLs, microprocessors and op-amp circuits. Components and wire leads can be quickly inserted, removed and changed without the need for soldering or desoldering. The 3 power supplies incorporated in the JE450 provide the user unlimited use in prototyping circuits. • Size: 9¾"L x 6¾"W x 3¼"H • Weight: 6 lbs. • Power supplies, regulated: 5V @ 1A, +5V to +15V @ .5A, -5V to -15V @ .5A • Power: 120VAC, 60Hz fused • For recommended wire jumpers see JE10 and JE11, below

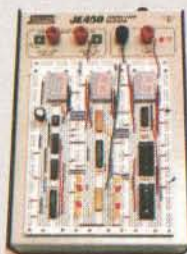

1-9 10-99

JE450 Solderless Prototype Builder. \$119.95 \$109.95

IC Test Clips

Jameco's IC Test Clips are designed to facilitate temporary connections to DIP package components. A heavy-duty spring-loaded hinge provides positive contact even after thousands of uses.

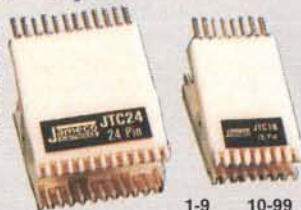

Part No.	Description	1-9	10-99
JTC16	16-pin (used for 8, 14 and 16-pin IC's)	\$4.49	\$3.95
JTC20	20-pin (used for 18 and 20-pin IC's)	\$5.95	\$5.49
JTC24	24-pin	\$6.95	\$5.95
JTC28	28-pin	\$7.95	\$6.95
JTC40	40-pin (used for 36 and 40-pin IC's)	\$9.95	\$8.95

Wire Jumpers

• The JE10 Wire Jumper Kit comes with 350 assorted lengths and colors of pre-stripped and pre-formed 22AWG solid wire jumpers all in a handy, durable plastic case. The kit includes 25 each of the following lengths: .1", .2", .3", .4", .5", .6", .7", .8", .9", 1.0", 2.0", 3.0", 4.0" and 5.0" • The JE11 contains all of the same wire jumpers included in the JE10 and makes a convenient refill package.



Part No.	Description	1-9	10-99
JE10	Wire Jumper Kit 350 ea. (includes case)	\$7.95	\$7.49
JE11	Same as JE10 except case not included	\$6.95	\$5.95

266 **For complete product line, request Jameco's new 74 page 1989 Catalog**

Kingdom Handheld Analog Multimeters Kingdom

• Mirrored Scale for Accuracy • Audible Continuity Test • Fuse/Diode Overload Protection
Both units come complete with probes, batteries and manual. Size: 6"H x 4.125"W x 1.75"D

ET207 Specifications: • AC Voltage: 10-1000VAC • DC Voltage: 0.25-1000VDC • DC Current: 50µA-10A
• Resistance: 1Ω to 10MΩ • Decibels: -10 to +62dB at ACV ranges • Accuracy: ±3 to ±4% on all ranges • Sensitivity:
9KΩ/VAC, 20KΩ/VDC • Audible continuity test • Battery Tester

***ET207** 20KΩ/Volt Analog Multimeter w/DC Current Measurement and Battery Tester . . . **\$15.95**

ET302 Specifications: • AC Voltage: 2.5-1000VAC • DC Voltage: 0.25-1000VDC • AC Current: 12A • DC Current:
50µA-12A • Resistance: 1Ω to 5MΩ • Decibels: -20 to +64dB at ACV ranges • Accuracy: ±3 to ±4% on all ranges
• Sensitivity: 10KΩ/VAC, 30KΩ/VDC • Audible continuity test

***ET302** 30KΩ/Volt Analog Multimeter with AC and DC Current Measurement. **\$22.95**



ET302

METEX Handheld Digital Multimeter METEX

The Economical Choice for a High Quality, High Accuracy Digital Multimeter
• 3.5 Digit (.5" High) LCD Readout • Audible Continuity Test • 1-Year Warranty

RANGE	ACCURACY	RESOLUTION
AC VOLTAGE		
200mV	±1.2% of reading	100µV
2V		1mV
20V	±0.8% of reading	10mV
200V		100mV
700V	±1.2% of reading	1V
DC VOLTAGE		
200mV		100µV
2V		1mV
20V	±0.5% of reading	10mV
200V		100mV
1000V		1V

RANGE	ACCURACY	RESOLUTION
AC CURRENT		
20µA		10nA
200µA	±1.0% of reading	100nA
2mA		1µA
20mA		10µA
200mA	±1.8% of reading	100µA
2A		1mA
20A	±3.0% of reading	10mA
DC CURRENT		
20µA		10nA
200µA	±0.5% of reading	100nA
2mA		1µA
20mA		10µA
200mA	±1.2% of reading	100µA
2A		1mA
20A	±2.0% of reading	10mA

RANGE	ACCURACY	RESOLUTION
RESISTANCE		
200Ω	±0.5% of reading	0.1Ω
2KΩ		1Ω
20KΩ	±0.5% of reading	10Ω
200KΩ		100Ω
2MΩ		1KΩ
20MΩ	±1.0% of reading	10KΩ

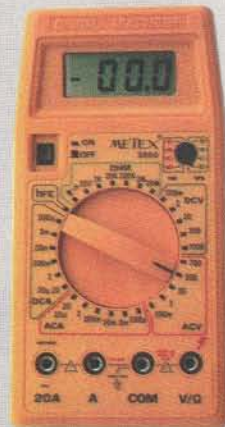

Unit comes complete with probes, batteries, carrying case and manual. Size: 6.75"H x 3.5"W x 1.25"D
Measures: AC/DC Voltage, AC/DC Current, Resistance, Diodes, Transistor hFE, Audible Continuity Test
• Auto Zeroing • Input Impedance: 10MΩ • Overload Protection: 1000VAC/VDC • One-Year Warranty

M3800 3.5 Digit Multimeter. **\$39.95**

METEX Handheld Digital Multimeters METEX

• Jumbo 3.5 and 4.5 Digit (.7" High) LCD • Audible Continuity Test • Overload Protection
• 1 Year Warranty • Ruggedized Case

AC Voltage (for M3610, M3650 and M4650)

Range	ACCURACY		RESOLUTION	
	M3610/M3650	M4650	M3610/M3650	M4650
200mV	±1.2% of reading		100µV	10µV
2V			1mV	100µV
20V	±0.8% of reading	±0.5% of reading	10mV	1mV
200V			100mV	10mV
750V	±1.2% of reading	±0.8% of reading	1V	100mV

Resistance (for M3610, M3650 and M4650)

Range	ACCURACY		RESOLUTION	
	M3610/M3650	M4650	M3610/M3650	M4650
200Ω	±0.5% of reading	±0.2% of reading	0.1Ω	.01Ω
2KΩ			1Ω	0.1Ω
20KΩ	±0.5% of reading	±0.15% of reading	10Ω	1Ω
200KΩ			100Ω	10Ω
2MΩ			1KΩ	100Ω
20MΩ	±1% of reading	±0.5% of reading	10KΩ	1KΩ

DC Voltage (for M3610, M3650 and M4650)

Range	ACCURACY		RESOLUTION	
	M3610/M3650	M4650	M3610/M3650	M4650
200mV			100µV	10µV
2V			1mV	100µV
20V	±0.3% of reading	±.05% of reading	10mV	1mV
200V			100mV	10mV
1000V	±0.3% of reading	±0.1% of reading	1V	100mV

Capacitance (for M3650 and M4650 only)

Range	ACCURACY		RESOLUTION	
	M3650/M4650	M3650	M3650	M4650
2000pF			1pF	0.1pF
200nF	±2% of reading		100pF	10pF
20µF	±3% of reading		10nF	1nF

Frequency (for M3650 and M4650 only)

Range	ACCURACY		RESOLUTION	
	M3650/M4650	M3650	M3650	M4650
20KHz			10Hz	1Hz
200KHz	±2% of reading		100Hz	10Hz

All units come complete with probes, batteries, carrying case & manual. Size: 7"H x 3.5"W x 1.5"D

M3610: • Measures: AC/DC Voltage, AC Current (200µA to 20A), DC Current (200µA to 20A), Resistance, Diodes, Transistor hFE, Audible Continuity Test • Auto-Zeroing • Input Impedance: 10MΩ • Overload Protection: 1000VAC/VDC

M3610 3.5 Digit Multimeter. **\$49.95**

M3650: • Measures: AC/DC Voltage, AC Curr. (2mA to 20A), DC Curr. (200µA to 20A), Resistance, Diodes, Transistor hFE, Audible Continuity Test, Freq. & Capacitance • Auto-Zeroing • Input Imped.: 10MΩ • Overload Protection: 1000VAC/VDC

M3650 3.5 Digit Multimeter with Frequency and Capacitance Measurement. **\$69.95**

M4650: • Measures: AC/DC Voltage, AC Current (2mA to 20A), DC Current (200µA to 20A), Resistance, Diodes, Transistor hFE, Audible Continuity Test, Frequency and Capacitance • Auto-Zeroing • Data Hold Switch • Input Impedance: 10MΩ • Overload Protection: 1000VAC/VDC

M4650 4.5 Digit Multimeter with Freq./Cap. Measurement and Data Hold Switch. **\$99.95**



M3610

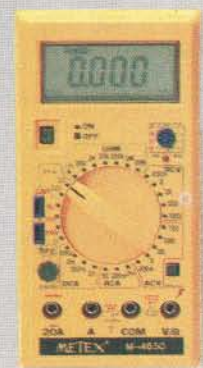

M4650

***CLOSE-OUT PRICING - PART NUMBER WILL BE DISCONTINUED WHEN STOCK IS DEPLETED!**

• Quality Components • Competitive Pricing • Prompt Delivery • (415) 592-8097

Programs 16K to 512K EPROMs, EEPROMs and PROMs, PALs, GALs, EPLs and PLDs

One-Year Warranty!

JE680 Features:

- Universal IC Programmer: memory and logic devices
- Stand-alone or computer-controlled modes
- Parallel printer port and RS232C port
- Automatic self-test on power up
- Auto-Sense
- Pin Check
- Split/Shuffle
- Full functional test on logic devices
- Patented design for programming reliability
- No personality modules needed
- Variable baud rates – up to 9600bps



JE680 Universal IC Programmer



JE680 Description of Operations:

The new JE680 Universal IC Programmer supports and programs virtually all devices from 16K to 512K and with up to 28 pins. The JE680 will program memory-type ICs such as MOS and CMOS EPROMs, EEPROMs and PROMs as well as logic-type ICs such as PALs, GALs, RALs, PLDs, EPLDs, EEPLDs and FLPDs. The JE680 programming algorithms meet all manufacturers' specifications and support STANDARD, INTELLIGENT and QUICK PULSE methods.

The JE680 supports 18 data formats, such as JEDEC, INTEL HEX, ASCII HEX, Motorola S and Binary. It is compatible with virtually all software package programs including: PALASM, PLAN, CUPL, ABEL, AMAZE and SGAPL. The RAM buffer EDIT function allows you to LIST, SET, INSERT, MOVE, DELETE and SWAP data.

Incorporated with the JE680 is a full array of TEST functions including Automatic Self-Test, Insertion and Backward-Device Check. The Auto-Sense allows the user to insert and remove ICs sequentially to automatically repeat an operation; no other action is required. The Pin Check examines individual pin continuity using pulse-reflection techniques; displays bad pin numbers. The Split/Shuffle function allows you to split your data up into even (high) and odd (low) bytes (8-bit), words (16-bit) or long words (32-bit). The Shuffle function allows you to reverse the procedure (see diagram, right). After programming your logic device, a full functional test ensures that your device has been programmed in accordance with your design. In addition to the loop test, the JE680 will perform consecutive test cycles to simulate worst-possible conditions so as to weed out logic devices with intermittent or other performance problems.

While the JE680 can be operated as a stand-alone unit, it can also be linked to an IBM PC/XT/AT or other compatible computer or to a data terminal. The user may output fuse-pattern and vector-table data or memory data to a printer. Specifications: • Input: 115VAC, 60Hz • Size: 15.6"L x 12"D x 3.7"H • Weight: 12.8 lbs. • One-Year Warranty

SPLIT BYTE EXAMPLE

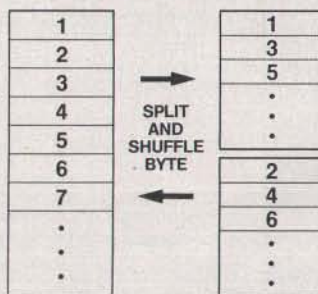

Part No.	Description	Price
JE680	Universal IC Programmer (Includes MS-DOS Menu-Driven Software, DB25 male to female cable and Centronics 36-pin male to female printer cable)	\$1799.95
JE680AP	Software option package for logic design applications (assembler package) – provides Boolean conversion, auto compiling and fuse map generation.	\$29.95

FOR OFFICE USE ONLY

ORDER# _____ OP _____

ORDER FORM



1355 Shoreway Road
Belmont, CA 94002
Telex 176043

24 HOUR ORDER HOTLINE (415) 592-8097

The Following Phone Lines Are Available From 7AM-5PM P.S.T.:

- Customer Service (415) 592-8121
- Technical Assistance (415) 592-9990
- Credit Dept. (415) 592-9983
- All Other Inquiries (415) 592-7108



FAX Your Order To Us!
(415) 592-2503 -or- (415) 595-2664



1989 CATALOG

Business Hours:
Monday thru Friday
7AM - 5PM P.S.T.

Effective October 1, 1988
Expires October 1, 1989
Prices Subject to Change

Mail Key: **889**

Customer Account No.

EXPEDITE YOUR ORDER BY INCLUDING YOUR
SIX DIGIT CUSTOMER ACCOUNT NUMBER

SHIP TO:

NAME: _____

ADDRESS: _____

Floor, Room, Suite No.: _____

CITY: _____

STATE: _____ ZIP: _____

METHOD OF PAYMENT:

- Prepaid (check enclosed) COD Credit Card
 Net 30 Days (Account must be previously established)

PURCHASE ORDER NO.:

Please check one: VISA MasterCard

Card Number: _____

Expires: _____

Mo. _____ Yr. _____

Name or number of bank that issued VISA or MASTERCARD: _____

AUTHORIZED SIGNATURE:

NAME (Please Print): _____

DAYTIME PHONE NO. () _____

EXT. _____

Item No.	PART NUMBER	QTY.	DESCRIPTION	DATA SHEETS	PRICE EACH	AMOUNT EXTENDED
1						
2						
3						
4						
5						
6						
7						
8						
9						
10						
11						
12						
13						
14						
15						
16						
17						
18						

DATA SHEETS

Includes descriptive data and
basic electrical requirements only.

TOTAL DATA SHEETS _____

@ .50 each

DOMESTIC ORDERS:

United States, Guam,
Puerto Rico, Virgin Islands

Postage and Handling: • First Class Mail - approx. 10% of the total order (\$4.00 min.);
UPS Ground - approx. 5% of the total order (\$2.00 min.), carrier delivery 5-7 days.
• UPS 2nd Day - approx. 10% of the total order (\$3.00 minimum), carrier delivery 2-3 days.
UPS Next Day Air - approx. 10% of the total order (\$11.50 min.). Charges will vary by weight.
Insurance: \$1.50 (not responsible for uninsured parcels)
Tax: California Residents only -
*Please include applicable sales tax for your area (i.e., 6%, 6½%, 7%)

Front and
Attached
Sheet**Sub-Total**

CALIFORNIA ONLY
6%, 6½%, 7% TAX*

FOREIGN ORDERS:

Canada, and
all others
not Domestic

Postage and Handling: 25% of total order (\$6.00 minimum)
Insurance: \$3.00 (only where postal regulations allow).

NOT RESPONSIBLE FOR CASH SENT WITH ORDERS OR UNINSURED PARCELS.
Payment: Cashier's Check, Money Order, VISA or MasterCard
(U.S. Funds only, payable through a U.S. Bank - please do not send cash)

\$10.00
24 Hour Service Charge
Non Refundable

Shipping and Handling:
 FCM UPS: Ground
 2nd Day Next Day Air

 \$1.50 Fee
Insurance

Credit Memo
(Must send orig.
packing slip)

TOTAL

CHANGE OF ADDRESS IF YOU HAVE MOVED

Please write your old and new address in the spaces provided.

-- OLD ADDRESS --

-- NEW ADDRESS --

Customer No. _____
Name _____
Company _____
OLD Address _____
City _____ State _____ Zip _____

Customer No. _____
Name _____
Company _____
NEW Address _____
City _____ State _____ Zip _____

**JAMECO THANKS YOU
FOR YOUR ORDER!**

• Quality Components • Competitive Pricing • Prompt Delivery • (415) 592-8097

269

Mail Order Electronics • Worldwide

Jameco ELECTRONICS

1355 Shoreway Road
Belmont, CA 94002
(415) 592-8097 24-Hour Order Hotline
(415) 592-8121 All Other Inquiries (7AM-5PM PST)
FAX 415/592-2503 • TELEX 176043
FAX 415/595-2664



U.S. MAIL • INCOMING PHONE ORDERS • COMPUTERIZED ORDER PROCESSING • Q.C. INSPECTION • COMPONENT PACKAGING • CUSTOMER SERVICE

24 HR ORDER HOTLINE — AUTOMATED PROCESSING

We Guarantee Good News Every Monday Morning!



In fact, we'll guarantee the best news—100% factual, accurate and unbiased expert analysis of significant developments in the personal computer industry. Just straightforward, no-nonsense professional reporting of industry news, product announcements and key events as they happen each and every week.

BYTEweek, McGraw-Hill's new weekly newsletter, is devoted to helping you stay on top of the dramatic changes in the continually-evolving business computing arena. BYTEweek is devoted to reporting and analyzing these changes and developments through its timely, compact, one-stop news format. BYTEweek keeps you on top of significant industry trends and developments through its coverage of the IBM, IBM-compatible, Apple Macintosh and workstation markets. BYTEweek gives you the full details of significant new product announcements with in-depth analysis.

BYTEweek guarantees what no other personal computing publication can by building on two renowned and respected technical resources: the award-winning *Microbytes Daily* on-line news service and the technical expertise of the BYTE Editorial Staff aided by the new resources available to them in the recently expanded BYTE Lab. Through these resources, you are kept on top of issues such as:

- **New data storage techniques**, including CD-ROM, erasable optical and other text, graphics, and video storage technology.
- **Expert systems**, with an examination of both the technical and human aspects of implementation.
- **Bus standards** and the war between IBM and the clone manufacturers—with critically

important user ramifications.

- **Legal skirmishes** and "look and feel" suits, which can put the manufacturer of your favorite software out of business.
- **Software emulation** that will allow new, exotic computer systems to run software written for IBM PCs.
- **LAN system developments**, including all pertinent aspects of connectivity and inter-operability.
- **Network management**, a complex and increasingly important topic for personal computers in both small and large offices.
- **PostScript clones**, which promise faster, lower-cost laser printers with the same capabilities as the Apple LaserWriter.
- **New, easy-to-use programming systems** such as CASE and 4th Generation Languages, that can allow non-programmers to develop powerful applications.

BYTEweek offers you what no other industry publication can: timely news on the rapidly evolving computer industry as it happens, framed by interpretation and evaluation that only BYTE's experienced editorial staff can provide.

Subscribe now and take advantage of the special one-year charter subscription rate of **\$395** (\$495 outside the U.S. and Canada)—a savings of **\$100** off the regular rate. Your subscription to BYTEweek includes 50 issues and a free subscription to BIX, which includes access to the award-winning *Microbytes Daily* on-line news service. Your hourly usage rates will be billed separately.

Don't miss this opportunity! Call BYTEweek's toll-free number:

1-800-258-5485

to order your subscription or request more information and a free sample issue.

BYTEWEEK

One Phoenix Mill Lane, Peterborough, NH 03458

1-800-258-5485

Charter subscription just \$395 for 50 weekly issues



Parallel Processing

275 Side by Side
by Klaus K. Obermeier

287 T800 and Counting
by Richard M. Stein

301 Getting the Job Done
by David Gelernter

311 The Third Dimension
by Michael J. Little and
Jan Grinberg

320 Boards and Boxes

Parallel processing could be described as the ultimate in teamwork. In fact, the kind of teamwork involved is not unlike that found in the football stadium on an autumn Sunday afternoon. The quarterback has his job to do, the center has his, the ends and backs have theirs, and the guards and tackles have theirs. All these jobs are under way at the same time, but they're all different and being done by a different player—parallel processing.

Similarly, when a group of people are raking leaves, different people are doing the same job, at the same time, with the result of significantly cutting down on the time required—also parallel processing. Not all jobs, however, can be done in parallel. That Thanksgiving turkey we look forward to at the end of the month can't be rushed—microwaves aside.

The same basic concepts apply in computing. Multiple processors operating in parallel can perform many, but not all, jobs faster than uniprocessors. A logically sequential program must still run sequentially. However, a modular program, or one that can be made modular, can run different sections on different processors and improve its speed.

Last summer, NASA's Jet Propulsion Laboratory introduced the Mark 3 Hypercube parallel supercomputer. Parallel processing has long been the exclusive realm of very large systems; however, it is now becoming available at the microcomputer level. For example, Zenith has announced the Z-1000 with its parallel 80386s (see Microbytes on page 11), and Cogent has come out with the XTM (see the text box "The Crossbar Connection" on page 278).

This month, we look at the world of parallel processing from the microcomputer view. In "Side by Side," Klaus K. Obermeier looks at the field as a whole:

the appropriate algorithms and applications; the programming languages, including old favorites and new ones with special parallel-processing functionality; and the hardware and operating-system architectures involved.

One particularly applicable piece of hardware is the transputer board. In "T800 and Counting," Richard M. Stein looks at the T800 transputer board from INMOS, discussing both the hardware aspects of the transputer and the related software aspects of the occam language—the two were designed to work together.

Another language designed for parallel processing on the transputer is Yale University's Linda. In "Getting the Job Done," David Gelernter, one of the language's designers, gives us the inside scoop on the current state of Linda, what it does, how it does it, and its specifically parallel features.

Finally, we have an article on a different way of making computers. In "The Third Dimension," Michael J. Little and Jan Grinberg describe the inner workings of Hughes Research Lab's 3-D Computer. It's an innately parallel computer built not of chips but of *wafers*—*stacks* of wafers. It's a fascinating technology.

While the concept and practice of parallel processing have a history in the large-computer arena, the idea of putting parallel-processing power on a desktop is still very new. The Mark 3 Hypercube is intended for simulations for the Strategic Defense Initiative. Can *that* kind of power really exist on a desktop?

—Jane Morrill Tazelaar
Senior Technical Editor, *In Depth*

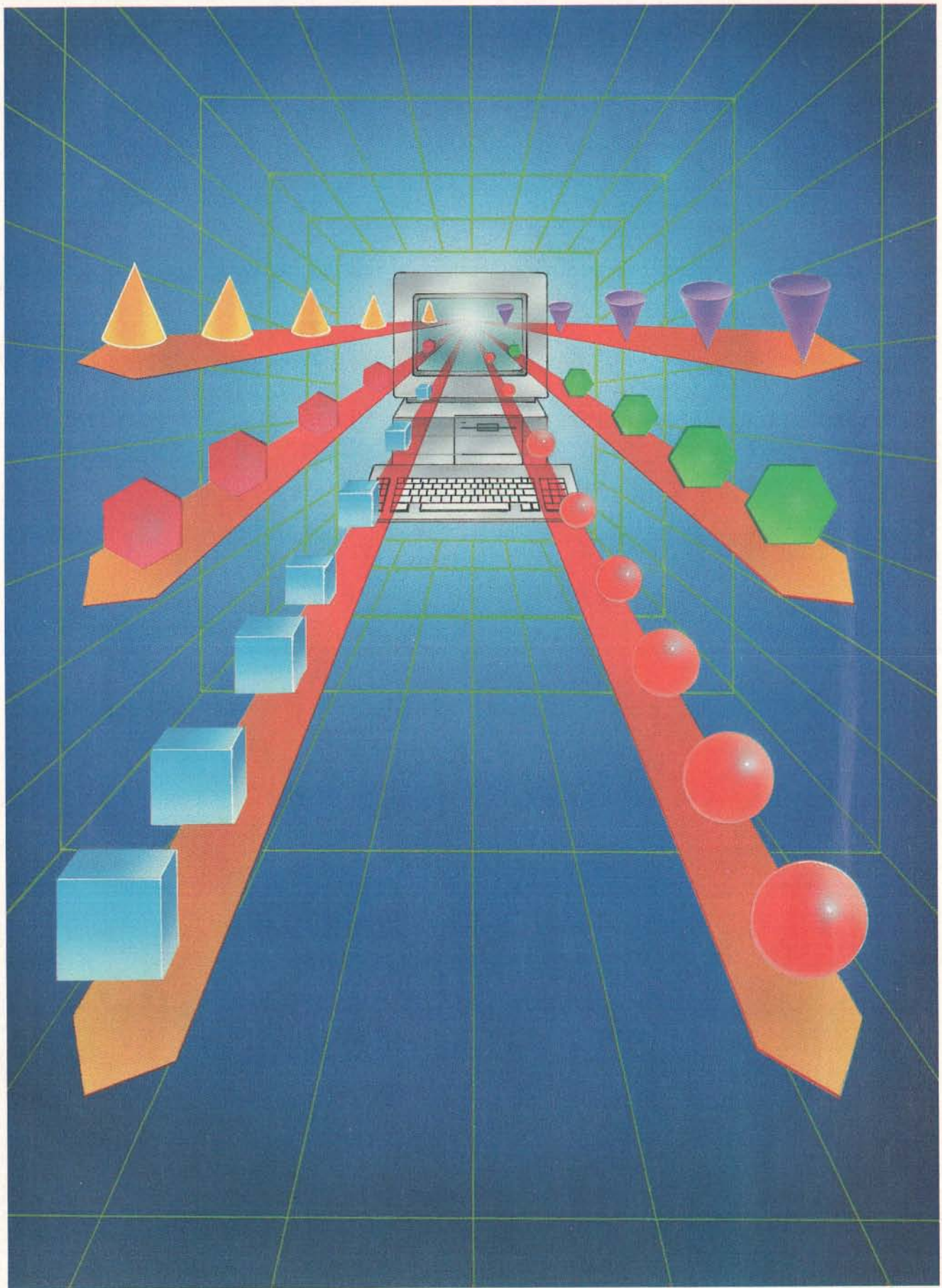

Discover Parallel Processing!

Monoputer/2™

*The World's Most Popular
Transputer Development System*

Since 1986, the MicroWay **Monoputer** has become the favorite transputer development system, with thousands in use world-wide. Monoputer/2 extends the original design from 2 to 16 megabytes and adds an enhanced DMA powered interface. The board can be used to develop code for transputer networks or can be linked with other Monoputers or Quadputers to build a transputer network. It can be powered by the 20 MHz T414 or T800 or the new 25 MHz T425 or T800.

Parallel Languages

Fortran and C Make Porting a Snap!

MicroWay stocks parallel languages from 3L, Logical Systems and Inmos. These include one Fortran, two Cs, Occam, Pascal, and our own Prolog. We also stock the NAG libraries for the T800 and Rockfield's structural and thermal finite element package. A single T800 node costs \$2,000, yet has the power of a \$10,000 386/1167 system. Isn't it time you considered porting your Fortran or C application to the transputer?

Quadputer™

*Mainframe Power
For Your PC!*

MicroWay's **Quadputer** is the most versatile multiple transputer board on the market today. Each processor can have 1, 4 or 8 megabytes of local memory. In addition, two or more Quadputers can be linked together with ribbon cables to build large systems. One MicroWay customer reduced an 8 hour mainframe analysis to 15 minutes with five Quadputers, giving him realtime control of his business.

For further information, please call MicroWay's Technical Support staff at (508) 746-7341.

Micro Way

World Leader in PC Numerics

P.O. Box 79, Kingston, MA 02364 USA (508) 746-7341
32 High St., Kingston-Upon-Thames, U.K., 01-541-5466
USA FAX 617-934-2414 Australia 02-439-8400 Germany 069-75-1428

Side by Side

You can only simulate true parallelism on your personal computer today, but tomorrow will be another story

Klaus K. Obermeier

A parallel-processing computer, simply defined, is one that can perform operations using more than one processor simultaneously. You can generally divide parallel processing into three major areas of research: algorithms and applications; programming languages; and architecture, including hardware and operating systems.

Where to Start

The conventional serial computer suffers from one serious drawback: the way the CPU accesses memory. While data is being retrieved from memory, it is actually written into a processor register, and after the register is incremented, the new value is put back into memory. During this period, the CPU remains idle. This phenomenon, known as the von Neumann bottleneck, accounts for the sometimes slow and inefficient use of conventional serial-processor resources.

But parallel processing has been around longer than the von Neumann bottleneck. As early as 1840, Charles Babbage conceived of a way to perform multiplication and indexing arithmetic simultaneously. The first operating par-

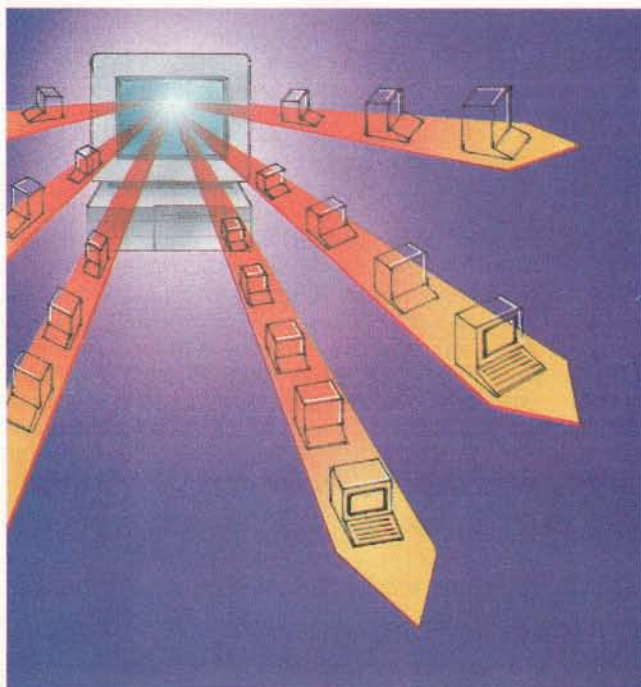

allel processor was the ILLIAC IV. This machine, developed by Dan Slotnick in 1966 at the University of Illinois, featured 64 processors.

Although the first commercial parallel-processing system flopped—the \$7 million Heterogeneous Element Processor, developed in 1985 by Denelcor—by 1986 more than a dozen companies were either selling or in the process of building

parallel processors, including Bolt Beranek and Newman, Cray Research, DEC, IBM, Intel, Alliant, Encore, and Thinking Machines.

Today, parallel-processing systems, such as the Connection Machine from Thinking Machines, can execute a few billion operations per second using up to 65,536 processors simultaneously. Searching a database of over 30,000 documents (18 megabytes) on a 16,384-element Connection Machine takes about 0.004 seconds for a Boolean query with 25 terms. Dow Jones recently purchased two 32,000-processor, 256-megabyte Connection Machines for use with its information-retrieval services.

The Parallel Approach

The central problem parallel-processing systems face is how to effectively and efficiently use more than one processor at the same time. A system's effectiveness depends on whether you can identify a problem that lends itself to parallelism, determine the algorithm, and map it onto a suitable architecture.

As you can imagine, problems arise if more than one processor requires access

continued

to the same memory location or if more than one processor tries to increment data in the same memory location. Therefore, the common argument that more processors are always faster than one holds true for systems that can cope with problems such as contention and have appropriate synchronization mechanisms in place.

Another factor that can prevent successful use of parallelism is the bottom-up approach parallel-processing-system architects often take to hardware design. Simply put, they sometimes don't consider the needs of the application designer when they configure the hardware. People who write parallel applications should always keep in mind the target architecture so they can be sure their application-design algorithm will be suitable (e.g., whether they will use message passing or shared memory).

The use of parallelizing compilers is no answer to this problem. Parallelizing compilers are most suitable when past investment does not warrant rewriting the existing software. The programmer has to consider the problem from two sometimes opposing points of view: top-down for the design of the algorithm and bottom-up for the actual implementation.

Algorithms and Applications

Parallel processing's most common applications are simulation, modeling, and optimization programs for commercial use. Airline scheduling is among the potential applications—calculating seat assignments and about 200,000 to 250,000 necessary changes in routing daily takes United Airlines' current aircraft assignment model 15 hours of CPU time. If you were a programmer faced with such a task, you would first break down the task into sizable chunks that could be processed in parallel and then worry about synchronization between the processors. Unfortunately, your creativity for designing a solution would be hampered by the existing operating system and the idiosyncratic architecture of the target hardware.

What you should first do in such a situation is decide the necessary *granularity* of the application. Granularity refers to the amount of time being spent on communicating versus computing in a parallel program. In a coarse-grained application, the parallel-processing system consists of large independent chunks with little time—on the order of hundreds of communications per second between processors—spent on communicating between the individual processors. In a fine-grained application, more time—

millions of communications per second—is spent on communicating and synchronizing between the processors. In any case, you have to leverage your solution with the encountered architecture. In the example of the aircraft assignment task, a processor may be assigned to one flight in a fine-grained system and to an entire aircraft in a coarse-grained system.

Once you determine the application's granularity, consider what form the communication between processors should

P *people*
who write parallel
applications should
always keep in mind the
target architecture.

take, via shared memory or message passing in distributed systems. While processors in a shared-memory system communicate via a common data structure, message passing takes place between two processors. Ultimately, atomic operations (e.g., locks, semaphores, and monitors) take over the task to synchronize processors properly. Once the algorithm is in place, it has to be synchronized with a specific parallel-processing architecture. What role do the programming languages play in matching algorithms to architectures?

Programming Languages vs. Compilers

For parallel processing, programmers can choose between parallelizing compilers and genuinely parallel programming languages. Parallelizing compilers are often used because of the high investment in existing application software or in bringing the programmers up to speed. As with digitizing old recordings, parallelizing serial algorithms doesn't work as well as algorithms genuinely conceived for parallel implementations. And as for the alleged complexity of writing programs in parallel, according to Chuck Seitz, chief designer of Cal-Tech's Cosmic Cube, the precursor to Hypercube, all other things being equal, "Programming experimental computers like the Cosmic Cube is not much harder

than programming sequential computers, if the problem lends itself to a concurrent solution."

According to David Gelernter of Yale University, parallel-programming languages can be classified into three categories: Algol-based languages (e.g., Ada, Linda); parallel Lisps and logic languages (e.g., Multilisp, Concurrent Prolog); and parallel functional languages (e.g., Paraf1).

Algol-based languages span the spectrum from Ada, originally designed for systems that execute sequentially, to Linda, especially conceived for parallel processing. Whereas Ada includes tools to support parallel processing, a parallel program written in Linda is, according to an article by S. Ahuja, a "spatially and temporally unordered bag of processes, not a process graph."

The Linda system consists of operators that can turn any host language (e.g., FORTRAN or C) into a parallel-programming language. However, it is an autonomous language consisting of a run-time kernel for synchronization and a compiler. Furthermore, it allows for parallelism both in the form of partitioning simultaneous processes and in replicating identical ones. (See "Getting the Job Done" on page 301.)

Parallel Lisps focus on symbolic rather than numeric parallel processing. The difference between the two, according to Robert Halstead, is that "numerical programs may be described as delivering numbers to an arithmetic unit to calculate a result," whereas "symbolic computation emphasizes rearrangement of data." Consequently, parallel Lisps are prime candidates for artificial-intelligence applications with an emphasis on operations such as recursion on trees and lists, rather than iterations in the form of loops for numerical computations.

Parallel functional programming includes a methodology that allows mapping programs to parallel-processing topologies. According to Paul Hudak, the most important aspect of this methodology is that "it treats the multiprocessor as a single autonomous computer onto which a program is mapped, rather than as a group of independent processors that carry out complex communications and require complex synchronization." Rather than having side effects from assignment statements, functional languages guarantee that a program will have the same result regardless of the order in which it has been executed. Therefore, in functional languages the parallelism is implicit and supported by

continued

Experteach-III

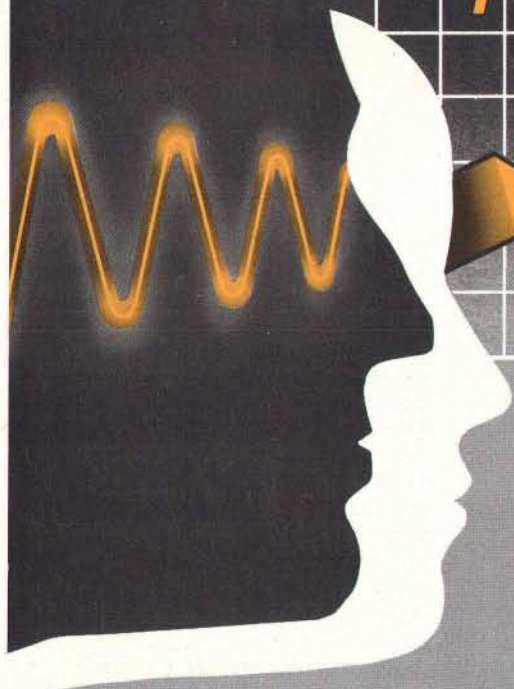

Teach yourself Expert Systems Technology Interactively on your IBM PC with this Comprehensive On-line Study Course

Experteach-III Includes:

- The Structure of Expert Systems.
- Inference, Forward and Backward Chaining.
- Inexact Reasoning.
- Frames and Inheritance.
- Intelligent Database Systems.
- Knowledge Acquisition.
- Knowledge Representation.
- Building Expert Systems.
- Automatic Knowledge Acquisition Systems.
- Machine Learning and Induction.
- Expert System Verification.
- Case Studies of Expert Systems.
- Use of Conventional Languages.
- Source Code in C and Pascal.

IntelligenceWare, Inc.

Leading in Artificial Intelligence Applications™

Experteach-III and IntelligenceWare are trademarks of IntelligenceWare, Inc. IBM PC is a trademark of IBM Corporation.

Experteach-III is a comprehensive guide to Expert System Technology consisting of a uniquely integrated collection of Expert System tutorials, case studies, and interactive on-line teaching programs.

You are introduced to Expert Systems technology with easy to understand text and interactive tutorials allowing you to test your comprehension of the concepts presented. Experteach-III draws its power from the uniform integration of Expert System concepts and provides you with a broad and overall view of the Expert System field.

A clearly written tutorial text is included along with well designed on-line interactive tutorials. Together, they provide a concise exposition of Expert Systems technology. Experteach-III graphically explains concepts such as forward and backward chaining, pattern matching, backtracking, conflict resolution, inexact reasoning, frames and inheritance, object oriented programming, etc. These concepts are explained in a step-wise, easy to understand manner.

Experteach-III provides an in-depth understanding of the inner structure of Expert Systems technology.

Experteach-III is based on extensive experience in teaching Expert System concepts in association with IEEE, ACM, UCLA, and the Continuing Education Institute.

IntelligenceWare, Inc.
9800 S. Sepulveda Blvd., Suite 730
Los Angeles, CA 90045
(213) 417-8896

I don't want to let technology pass me by!
Send ___ copies of Experteach-III at \$129 each.

Check or money order payable to IntelligenceWare, Inc. is enclosed.

Charge my Visa MC AMX
No. _____ Exp. Date _____

Shipping and handling, US: \$5, Canada and Hawaii Air: \$15, Overseas Air: \$25.
CA residents please add 6.5% sales tax.

Send me information on other IntelligenceWare Products.

Name _____

Company _____

Address _____

Tel. No. _____ Ext. _____

Signature _____

System Requirements: IBM PC, PC/XT ISBN 0-945877-01-3
or PC/AT 512K memory

The Crossbar Connection

Frank Hayes

Two processors should be twice as fast as one, and a thousand processors should be a thousand times as fast—at least in theory. But that depends on getting those thousand processors talking to each other, and that's not an easy task. In a fully connected network, interconnecting only 30 processors requires 435 separate connections; 1000 processors would require 499,500 connections.

A fixed network structure (such as a Hypercube) avoids that problem by connecting each processor to only a few neighbors, but then data must be passed from processor to processor through the network for distant processors to communicate. Alternatively, all the processors can share a common communications bus, but that risks tying up the bus if two processors have lots of data to exchange, bringing communications for

the rest of the system to a screeching halt.

Cogent Research in Beaverton, Oregon, thinks there's a better solution. Cogent's new desktop supercomputer, the XTM (see photo A), can connect any number of parallel processors, without passing data hand-to-hand through a network or tying up a common bus when there's lots of data to exchange. Instead, the Cogent machine has a hybrid communications architecture that has both a common bus and a unique network system.

The Cogent XTM

The XTM's processors are INMOS T800 transputers. Each transputer has 4 megabytes of RAM, as well as four high-speed serial-communications channels specifically designed for exchanging data with other transputers.

In the XTM, the transputers all share an ordinary parallel-communications bus, through which messages can be sent. Separately, the four serial-communications channels from each transputer are connected to an intelligent switching system. Inside the intelligent switch, the serial-communications channels from all the transputers in the system are arranged in a network—but with no permanent connections. Upon request, the intelligent crossbar switch can directly connect any two transputers in the network. Consequently, any two transputers can talk either through the shared bus or through a temporary "private" direct connection (see figure A).

For example, suppose processor A wants to send a large collection of data to processor B. If A sent the data through the common bus, it would tie up the bus—a classic communications bottleneck. Instead, A sends a message through the bus to the crossbar-switch controller, asking for a direct connection to B.

Once the connection is made, A can send data to B at high speed without interfering with any other processor's communications. Once the data transfer is complete, A sends another message to the switch controller, asking it to disconnect A from B, and the two processors are free to make new connections.

Meanwhile, every other pair of processors in the system can be connected in the same way. While A and B are exchanging data, C and D can make their own connection. At least in theory, in a 1000-processor system, 500 serial connections could be transferring messages at high speed.

It takes the XTM's intelligent crossbar switch less than 40 microseconds to link any two processors, and only 200 to 400 μ s to completely reconfigure the entire computer. (The XTM can even be reconfigured to mimic a Hypercube or another fixed network.)

Because the communications network is dynamically reconfigurable, all the processors can communicate directly through a relatively small number of communications channels. One thousand processors can communicate using only 4000 serial lines—less than 1 per-



Photo A: Cogent Research's XTM parallel desktop supercomputer, based on the INMOS T800 transputer and Yale University's Linda programming language. (Photo courtesy of Cogent Research, Inc.)

cent of the number required for a fully connected network. As a result, the number of processors in the system is almost unlimited. Cogent has designed a system for Sandia National Laboratory that contains 1900 processors and has roughly the same computing power as a Cray X-MP.

A more typical Cogent XTM system sits on a desktop and has two processors in a workstation cabinet that's slightly smaller than an IBM PC (14 by 14 by 6 inches). Along with the processors, the workstation contains a 90- or 190-megabyte hard disk drive, an 800K-byte 3½-inch floppy disk drive, and three NuBus slots.

There are also an external 1024- by 808-pixel display, a keyboard, and a mouse. The least expensive XTM system (with a 90-megabyte hard disk drive and a monochrome display) costs \$19,800.

To add processors to this basic system, you first need to add a resource server (a 14 by 18 by 6 cabinet with 16 slots and the intelligent crossbar switch) and a communications card to connect it to the XTM.

As a result, going from two processors to four adds another \$35,000 to the price. After that, you can add computation cards (each one contains two transputers) for \$12,000 each—until you run out of slots in the resource server, at which time you can add another resource server. Additional disk storage comes in the form of a disk server (1.9 gigabytes, plus an 810-megabyte optical drive for backup, for \$60,000). The workstation, resource servers, and disk servers all communicate through fiber-optic cable at 100 megabits per second.

An Easy Growth Path

The price on a desktop supercomputer can rise quickly. A workstation with a single resource server packed full of processors fits easily on a desktop—and costs over \$200,000. The Cray-class system Cogent designed for Sandia will cost \$15 million to build.

But the XTM is unique among supercomputers in that both the two-processor minimal system and the 1900-processor Sandia machine use exactly the same hardware. And with enough time

and money, you can build any system into a colossus—without changing the software. The XTM's operating system is based on the Linda parallel-programming concept, which is effectively blind to the number of processors in the computer. A program written in FORTRAN or C using the Linda extensions will run on a minimal XTM system. Add two (or a dozen) more processors, and the program will run in exactly the same way—but nearly twice (or a dozen times) as fast.

And how fast is fast? Each of the XTM's transputers adds 3 million floating-point operations per second of processing power. Cogent's designers believe that because the XTM can be so easily tailored to match computational problems—adding more number-crunching capability as it's needed—the new machine will open up a completely new range of problems that were previously inaccessible from desktop workstations.

Frank Hayes is an associate news editor for BYTE in San Francisco. He can be reached on BIX as "frankhayes."

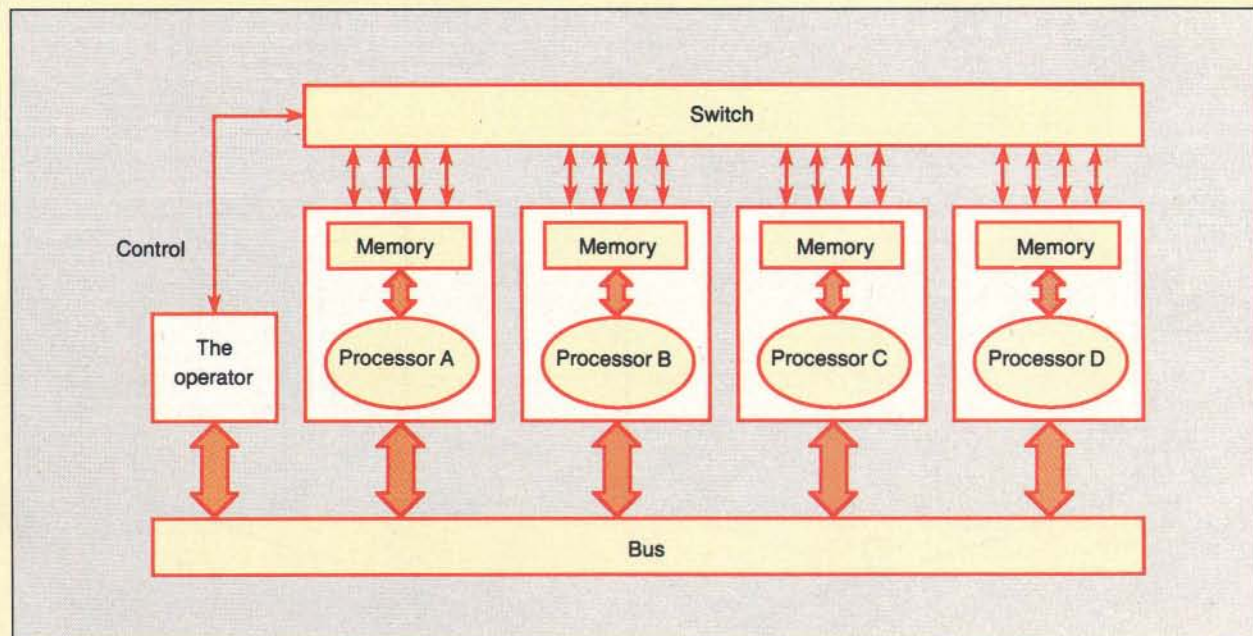

Figure A: The Cogent XTM's communications system. For A to exchange data with B, A notifies the switch controller via the communications bus. The controller then orders the intelligent switch to make a direct connection between A and B.

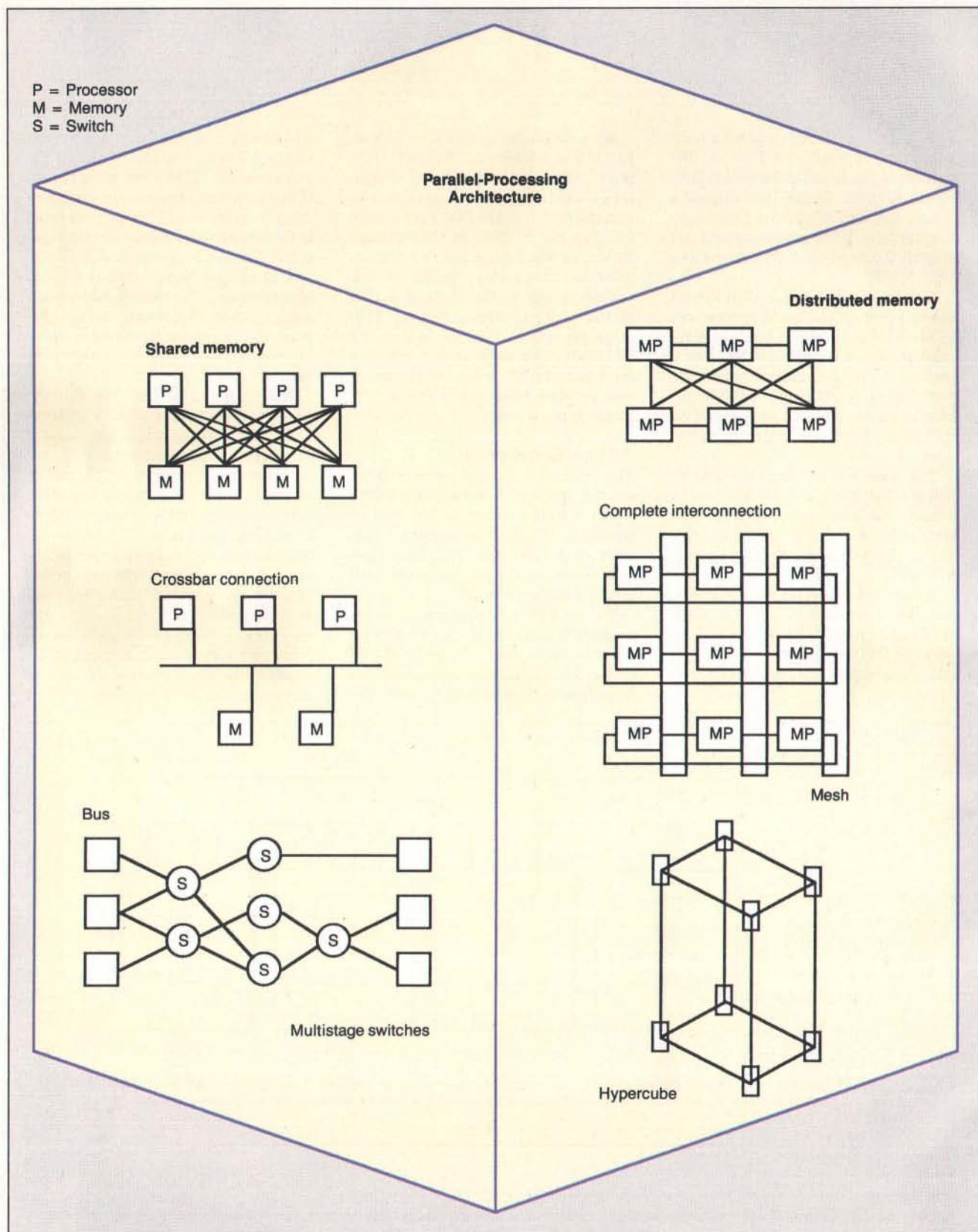

Figure 1: Shared memory architectures allow parallel systems to access a common shared memory, as opposed to distributed memory systems, which provide memory to each processor.

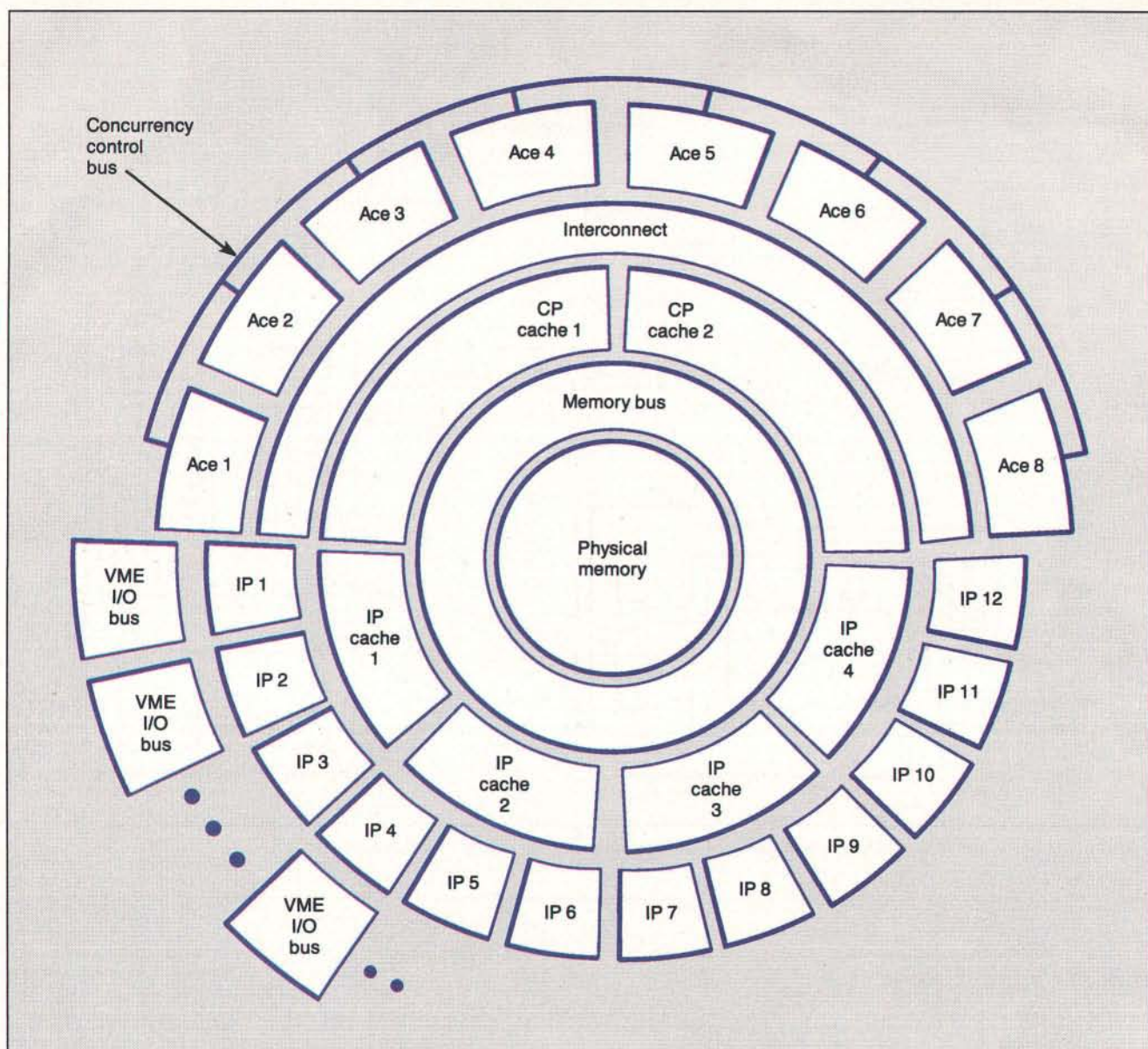

Figure 2a: The FX/8 system's common-bus architecture. The ACE processors (Advanced Computational Elements) function as application processors. I/O and operating-system jobs are performed by the interactive processors, which are 68020-based.

underlying semantics. In brief, functional languages are prime candidates for programming parallel machines.

All about Architecture

A dichotomy exists between shared-memory architectures and distributed-memory architectures. The former allow parallel systems to have access to a common, shared memory, while the latter give each processor its own memory. As shown in figure 1, a multitude of configurations is possible and has been used for building parallel-processing systems.

The most widely used architectures are bus-based systems, the Hypercube,

and a design using special-purpose switches, as shown in figures 2a, 2b, and 2c. A less widely known architecture is found in wafer technology. (See "The Third Dimension" on page 311.)

Bus-based systems (e.g., the FX/8, from Alliant Computer Systems, Littleton, Massachusetts) provide the simplest form of parallelism, having a set of processors connected to a set of memory boards via a common bus. Although these systems are attractive for their simplicity, problems arise in the form of limited scalability, contention for accessing the same memory location, and rising costs for overall speed gain. In ap-

plications dominated by scalar code, like older mechanical CAD applications, you'll find good speed increases with from one to four processors, but after that, adding processors won't increase speed.

Hypercube (e.g., the Connection Machine from Thinking Machines, Cambridge, Massachusetts), based on CalTech's Cosmic Cube, allows multidimensional connections between processors, thus connecting every processor at least indirectly. Although it's attractive for its capability to interconnect thousands of individual processors, communication speed between processors may

continued

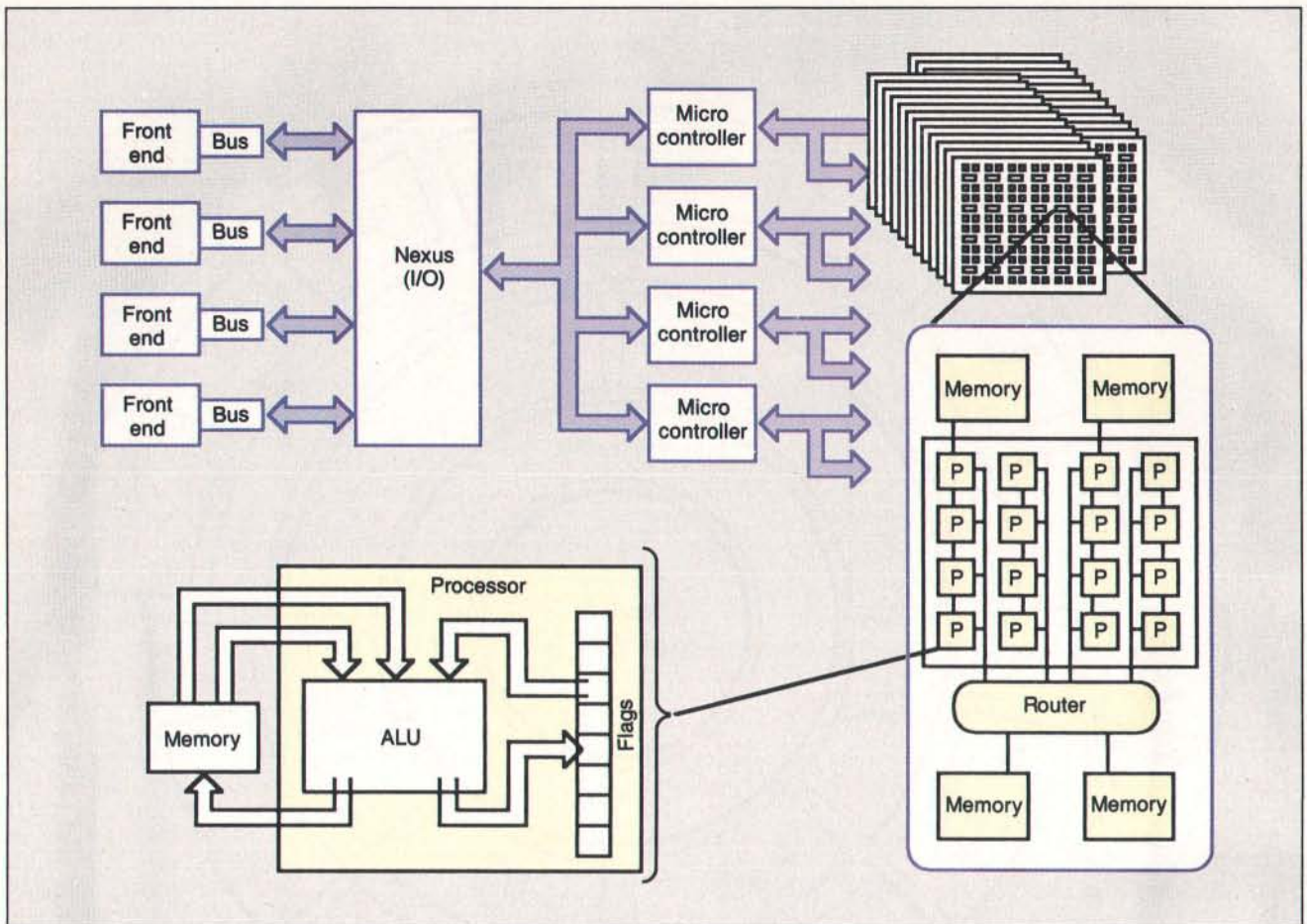

Figure 2b: The Connection Machine's Hypercube architecture and blowup of individual processor.

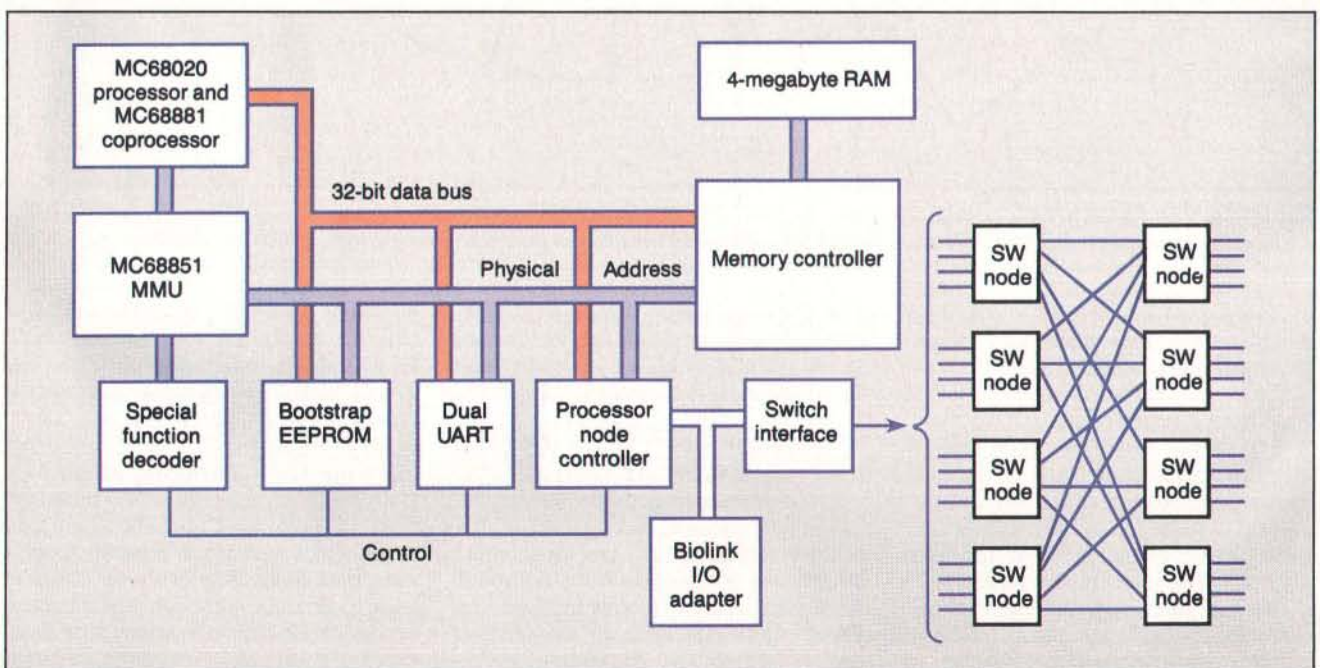

Figure 2c: A Butterfly processor node block diagram and blowup of the Butterfly switch design.

vary depending on the number of intervening processor nodes. Ultimately, programming a Hypercube architecture may require treating it as a loosely coupled multiprocessor with explicit data placement and task assignment per node under certain memory size limitations.

Multistage switch architectures (e.g., the Butterfly from Bolt Beranek and Newman, Cambridge) are closely modeled around crossbar switching connections that use separate buses for each processor. Whereas crossbar architecture has a serious contention problem, if two processors want to communicate with the same memory location at the same time, special-purpose switches allowing multiple paths to the same memory node alleviate the contention problem. (See the text box "The Crossbar Connection" on page 278.)

The Problem with Benchmarking

In general, benchmarking parallel-processing systems is a formidable, if not impossible, task. While you can use MIPS (million instructions per second) and MFLOPS (million floating-point operations per second) to compare parallel-processing machines, their ratings may be skewed by I/O-intensive programs or the types of programs themselves. Moreover, transporting code between parallel-processing machines of different types is not possible.

A popular dichotomy between right-wing and left-wing machines points to the important role of the operating system. Just as ideological differences set conservatives apart from liberals when it comes to the role of the government, right-wing machines (e.g., Hypercube-based) offer little control or support through their operating systems. With these machines, programmers are required to code more low-level operations themselves. Left-wing machines (e.g., Butterfly) provide more generous support by the operating system.

The Personal Computer Connection

While parallel processing has reached the minicomputer market, parallel-processing capabilities for personal computers are slowly emerging and usually come in two forms: expansion boards and software simulation. (See "T800 and Counting" on page 287.) The INMOS D700 Card and T414 CPU offer IBM PC users parallel-processing capabilities as part of the D701 Transputer Development System. The package comes with the Algol-based programming language occam. The T414 CPU, a 32-bit microprocessor, is able to pass information to

multiple processors while at the same time operating on a problem.

Another expansion board that offers parallel-processing capability is the PCTurbo 286e from Orchid Technology. The board connects to the IBM PC AT or XT and lets you run simultaneous applications in the computer's standard memory and the 286e's RAM. If you choose to run two programs in parallel that try to access the same data or write to the same disk sector, the data may be compromised.

P Parallel- processing capabilities for personal computers are slowly emerging.

The complexity and cost of commercial parallel-processing machines available today make them prohibitively expensive for mass use. The available expansion boards that may allow some parallel processing on personal computers are primarily for the programmer exploring the flavor of this technology. Integration into existing infrastructures makes personal computers probable candidates for host or front-end vehicles.

Where We Are Going?

Parallel processing, despite its commercial impact over the past 5 years and its academic endeavors over the past 20 years, is still in an embryonic state. The three most significant issues standing in the way of necessary commercial breakthroughs are standardization of parallel-processing languages and architectures, integration of parallel processing into the existing computing infrastructure, and design of solid interfaces required by the complexity of the programming tasks.

Standardization of parallel-processing languages and architectures is important because there is currently no standardization of parallel-processing techniques in sight. One reason for this is that parallel-processing technologies are still mostly in R&D laboratories, an environment that promotes individualism. Another reason is the potential for diverse applications that makes it impossible to predict what such standards should look like. Finally, the design of hardware is so

far ahead of the state of the art in software development that both disciplines have to be brought to the same level before standardization of either software or hardware becomes possible.

Integration of parallel processing into the existing computing infrastructure is important because drastic changes are slow to be implemented, especially in an investment-intensive area like software development and hardware purchases. Although projects like the one that involves Dow Jones and Thinking Machines show some promise, many more successful applications have to come about before parallel processing becomes a major force in the commercial computing market. As with any other innovation, commercial evolution has to follow the revolution in the laboratories. Integration is the key.

Last but not least, the design of solid interfaces required by the complexity of programming tasks is a necessity. As we are beginning to imagine programming parallel systems of multiple gigabytes in size, debugging and maintaining such programs, much more than actually using them, will be delegated to the user interface. Ultimately, programs may come about through the intelligent interaction in English between the user and the interface.

For these reasons, personal computer users will have to limit themselves to simulating parallelism in the near future—that is, until commercial parallel-processing technology matures. ■

BIBLIOGRAPHY

- Chandy, K., and Misra, F. *Parallel Program Design*. Reading, MA: Addison-Wesley, 1988.
- Dongarra, J. C., ed. *Experimental Parallel Computing Architecture*. Amsterdam: Elsevier Science Publishing Co., 1987.
- Fox, G. C., and Messina, P. C. "Advanced Computer Architectures." *Scientific American*, October 1987, pp. 66-77.
- Frenkel, K. A., ed. "Parallel Processing." *Communications of the ACM*, vol. 29, no. 12, December 1986, pp. 1168-1239.
- Gelernter, D., ed. "Domesticating Parallelism." *Computer*, vol. 19, no. 8, August 1986, pp. 12-72.
- Gullo, K., and Schatz, W. "The Supercomputer Breaks Through." *Datamation*, vol. 34, no. 9, 1988, pp. 50-63.
- Hillis, W. D. *The Connection Machine*. Cambridge, MA: The MIT Press, 1986.

Klaus K. Obermeier is a projects manager of the AI Group at Battelle Laboratories in Columbus, Ohio. He can be reached on BIX c/o "editors."

The New

PC NETWORK

625 ACADEMY DRIVE NORTHBROOK, IL 60062

Come Visit Our Computer Warehouse Club Outlet Store • Come Visit Our Computer Warehouse Club Outlet Store • Come Visit Our Computer Warehouse Club Outlet Store • Come Visit Our Computer Warehouse Club Outlet Store • Come Visit Our Computer Warehouse Club Outlet Store • Come Visit Our Computer Warehouse Club Outlet Store •

PRINTERS

NEC LC 890 \$2,950.00*

- 35 Resident type fonts
- 4 standard interfaces
- 3MB of internal memory



LC 890 Toner Cartridge (6Pk.) 62.10*

MODEMS

THE 2400 BAUD MODEM

100% Hayes compatible half height card modem w/ Bitcom communications software.

\$99.99*



THE@ 1200 BAUD External 85.85*
 THE@ 2400 BAUD External 129.00*

SYSTEMS

THE 286/12

•12K of 1MB on the Motherboard • 6-12Mhz • Keyboard/Toggle Switch Selectable • 1.2MB Mitsubishi HDC/FDC • Phoenix Bios • 101 Key Keyboard • Monitor & Video Board Optional



\$915.00*

BUY NOW AT DISCOUNT WHOLESALE + 8% PRICES !

BUSINESS SOFTWARE

ALDUS PageMaker 3.0	479.75*
ASHTON-TATE Dbase III+	345.32*
ASHTON-TATE Multimate Advan. II	235.00*
BORLAND INT Paradox 2.0	392.89*
BORLAND INT Quattro	129.00*
BORLAND INT Sidekick Plus	112.11*
BORLAND INT Sprint	108.50*
BORLAND INT Turbo C or Basic	56.05*
CENTRAL POINT PC Tools Deluxe	37.50*
DAC SFT DAC Easy Accounting 3.0	53.00*
LOTUS DEVELOPMENT Lotus 1-2-3	269.00*
MERIDIAN TECH Carbon Copy Plus	100.49*
MICROSOFT Works	116.15*
MICROSOFT Excel	265.00*
MICROSOFT Basic 4.0 or Windows	60.55*
MICROSOFT Word 4.0	199.00*
PEACHTREE SFT Actcing Sys II	146.45*
PETER NORTON Utilities-Advanced	68.25*
QUARTERDECK OFFICE Desqview	69.69*
SYMANTEC Q&A 3.0	186.85*
WORDPERFECT Wordperfect 5.0	205.00*
XEROX CORP Ventura Publisher	445.00*

MONO & COLOR CARDS

HERCULES Graphics Card Plus	170.69*
THE@ Color Card or Mono	55.00*
A.T.I. EGA Wonder 800 x 560	205.00*
ORCHID Designer VGA (IBM PC/XT)	287.31*
PARADISE Auto Switch 480	162.00*
PARADISE VGA Plus Card	253.00*
VIDEO 7 Vega Deluxe 640 x 480	185.14*
VIDEO 7 VGA	249.96*

COMPUTER SYSTEMS

AST Premium 286 Model 80	1,399.00*
APPLE Macintosh Plus, SE, MAC II	CALL
COMPAQ Deskpro 286/40MB	2,295.25*
COMPAQ Deskpro 386/60MB	5,089.00*
COMPAQ Portable III MDL 40	3,850.00*
IBM PS/2 Model 30 CMS 20MB	1,473.59*
IBM PS/2 Model 50	2,395.00*
TOSHIBA T-1000 Laptop w/512K	729.00*
TOSHIBA T-1200 HD w/20MB, backlit	2,193.00*
TOSHIBA T-5100 w/2MB RAM, 40MB	4,450.00*
TOSHIBA T-3200 Laptop	3,395.00*
NEC HD, 640L, 2MB, backlit	2,095.00*

Call For Best Pricing On Other Models

WordPerfect

Word Processing Software

\$205.00*



- Advanced word processing functions
- 100,000 word phonetic dictionary
- Split screen editing
- Use up to 5 different fields at once

FLOPPIES, DRIVES, TAPES

CMS 360K Ext. PS/2 Floppy	231.29*
10MEGA Bernoulli II 20MB Int	738.00*
IRWIN 64MB Int Tape for IBM PS/2	499.00*
IRWIN 145 40MB Internal Tape	419.65*
MINISCRIBE 3650 40MB Kit	360.57*
MINISCRIBE 360K 1/2 Ht Dr	79.79*
MITSUBISHI 1MB 3.5"FD	79.79*
MITSUBISHI 1.2MB Floppy 1/2 Ht	85.62*
PLUS DEVEL Hardcard 20	489.87*
PLUS DEVELHardcard 40	601.82*
SEAGATE ST-225 20MB Kit	249.00*
MINISCRIBE 3675 60MB HD Kit	389.00*
MINISCRIBE 6128 110MB RLL Full Ht	659.00*
SEAGATE ST-251 42MB/40MS HD	329.00*
SEAGATE ST-4096 80MB Full Ht	529.00*
SYSGEN Bridge File 3.5" Ext. Drive	205.00*

MITSUBISHI DIAMOND SCAN

13" Color Monitor

\$455.00*



NEC Multisync II Hi-Res 13" Monitor \$544.99*
 Call For Best Prices on Magnavox, Amdek, IBM, Princeton, and THE@

MODEMS

HAYES Smartmodem 2400	392.89*
HAYES Smartmodem 1200	261.59*
U.S. ROBOTICS HST 9600	579.00*

MULTIFUNCTION CARDS

AST Advantage Premium	295.00*
INTEL Above Board 286 w/512K	360.00*
ORCHID Tiny Turbo 286	241.39*
ORCHID Twinturbo 12	342.39*
THE@Multi I/O w/P/S/G/CLK/CAL	50.40*

MATH CO-PROCESSOR

INTEL 80287 10MHZ Co-Processor	250.00*
INTEL 8087-2 Math Co-Processor	147.00*
INTEL 80387-16 Co-Processor	415.00*

MICE & ACCESSORIES

LOGITECH Logimouse +	69.69*
LOGITECH Hi-Res Mouse	85.85*
MICROSOFT Mouse w/Paintbrush	93.50*
MICROSOFT Mouse w/Windows	125.00*
CENTRAL PT Deluxe Option Brd	106.05*
CURTIS Ruby + w/Fax Protector	63.63*
KENSINGTON Masterpiece+	99.99*
THE COMPLETE PC Complete Fax	297.95*
FUJI 3 1/2" DS/HD Box of 10	45.45*
UNISON Unipower 400 UPS	329.00*
640K & 256K CHIPS	CALL
DISKETTES (25) Hi Dens IBM AT	32.82*
DISKETTES (50) 5 1/4" DS/DD	17.50*

FAX MACHINES/COPIERS

SHARP FAX FO-300

Sharp's deluxe, full-featured compact fax with auto dialing and document feeder, 18 second transmission and programming polling/turn-around polling/timer polling.

SHARP FO20 Fax Paper (6 Rolls) 23.23*

\$1,131.20* SHARP

SHARP Z-50 Copier 487.83*
 SHARP Toner Cartridge 60.60*
 Call For Pricing On Other Models

REAL BUYING CLOUT- Call now and join over 200,000 members who are too smart to pay more!
MEMBERSHIP BENEFITS: * Pay just 8% above advertised wholesale price • 3% cash discount (included in wholesale price) • Price Protection • Optional software rental library • FREE Wholesale Buyers Guide • FREE UPDATES • Fully Insured 48 Hour Shipping • 10 day Return Policy • FREE Technical Support • FREE Bulletin Board • Quantity Discounts • All Prices Subject To Change. All Products Subject To Availability. **JOIN TODAY FOR AS LITTLE AS \$10.**

*All Prices Shown are Wholesale Prices

PLOTTERS/SCANNERS

HOUSTON INSTRUMENTS All Models	CALL
HEWLETT PACKARD Scanjet	929.00*
PANASONIC FX-RS505 Scanner	829.00*
IOLINE PLOTTERS	CALL
SUMMAGRAPHS(12 x 12)	342.39*
SUMMAGRAPHS(12 x 18)	564.59*

PRINTERS

PANASONIC

1080i	170.69*
1592	389.00*
KX-P4450 LASER	1,469.00*

CITIZEN

180D	166.65*
MSP-45	437.00*
Tribute 224	578.90*
Premier 35	489.00*

EPSON

LX800	176.00*
LQ500	CALL
LQ1050	CALL
FX1050	CALL
FX850	CALL

NEC

5200	489.00*
P5300	639.00*
P2200 Dot Matrix	317.14*

OKIDATA

ML 393	865.00*
ML 321	435.00*
ML 320	315.00*

HEWLETT PACKARD

Laserjet II	1,585.00*
Deskjet	651.45*

PANASONIC 1091I MDL.2

SAVE

192/32 CPS, 10" Par w/ tractor

\$165.00*



1-800-621-SAVE

Corporate & Export Order Hotline **1-312-205-1300**

MONDAY-FRIDAY 8:30AM-6:00PM SATURDAY 10:00AM-4:00PM

Major Credit Cards Accepted

TECH SUPPORT 1-312-205-1410
 CUSTOMER SERVICE 1-312-205-1510
 FAX 1-312-205-1525
 625 Academy Drive, Northbrook, IL 60062



BY1188

JOIN THE #1 "COMPUTER WAREHOUSE CLUB" FOR BUSINESS

The New **PC NETWORK**

Come Visit Our Computer Warehouse Club Outlet Store • Come Visit Our Computer Warehouse Club Outlet Store • Come Visit Our Computer Warehouse Club Outlet Store • Co

PRICE BREAKTHROUGH



T.H.E.  IBM Compatible

\$1,790*

386/16

- 1MB RAM • 32Bit 16 Mhz Operation
- 200 Watt Power Supply • 101 Key "AT Style" Keyboard • 1.2 MB Floppy • Western Digital Hard/Floppy Controller • Pheonix Bios • Monitor Optional

Unmatched Laser Speed



Panasonic
Office Automation

\$1,469*
89994450

Laser Partner

- 11 Pages Per Minute
- 512K Expandable to 1.5MB
- Font Cartridges
- Emulates HP Laserjet II, Diablo 630, Epson, IBM Proprinter
- 300 Dots Per Inch

9600 Baud Modem, Hayes Compatible

The Last Modem You'll Ever Buy



BEST BUY

\$399*

- 1200, 2400, & 9600 Baud
- Software Included
- Internal Card
- Hayes Compatible
- Auto Answer, Dial
- External Add \$50

T.H.E. Complete Computer Systems

Hard Drive Super Sale

Complete Color System \$798**



Complete Monochrome System \$540**

- ST-251**
- 42MB Half Height Hard Drive
 - 40MS Access Time



\$349**

MiniScribe

- 42MB half Height Hard Drive
- 40MS Access Time

Seagate

ST-225
20MB Half Height Hard Drive Kit **\$249****

- 512K Expandable to 640K RAM
- 360K Disk Drive
- 10Mhz Speed
- 101 Key Keyboard
- LED w/Keylock
- Serial/Parallel/Game/Clock
- Hercules Monochrome Video Card
- HI-RES 14" RGB Color Monitor or HI-RES 12" Monochrome Monitor
- FREE 1-Year Warranty
- Pheonix Bios & More!

Call For Your FREE Wholesale Buying Guide

1000's of Products at Wholesale Prices

1-800-621-SAVE

* All Prices Shown are Wholesale Prices

All Major Credit Cards Accepted

Corporate & Export Order Hotline **1-312-205-1300**

* Pay just 8% above the advertised wholesale price. Optional software rental library. Fully insured 48 hour shipping. 10 Day return policy. FREE Technical support. Quantity discounts. All Prices are subject to change. All products are subject to availability.

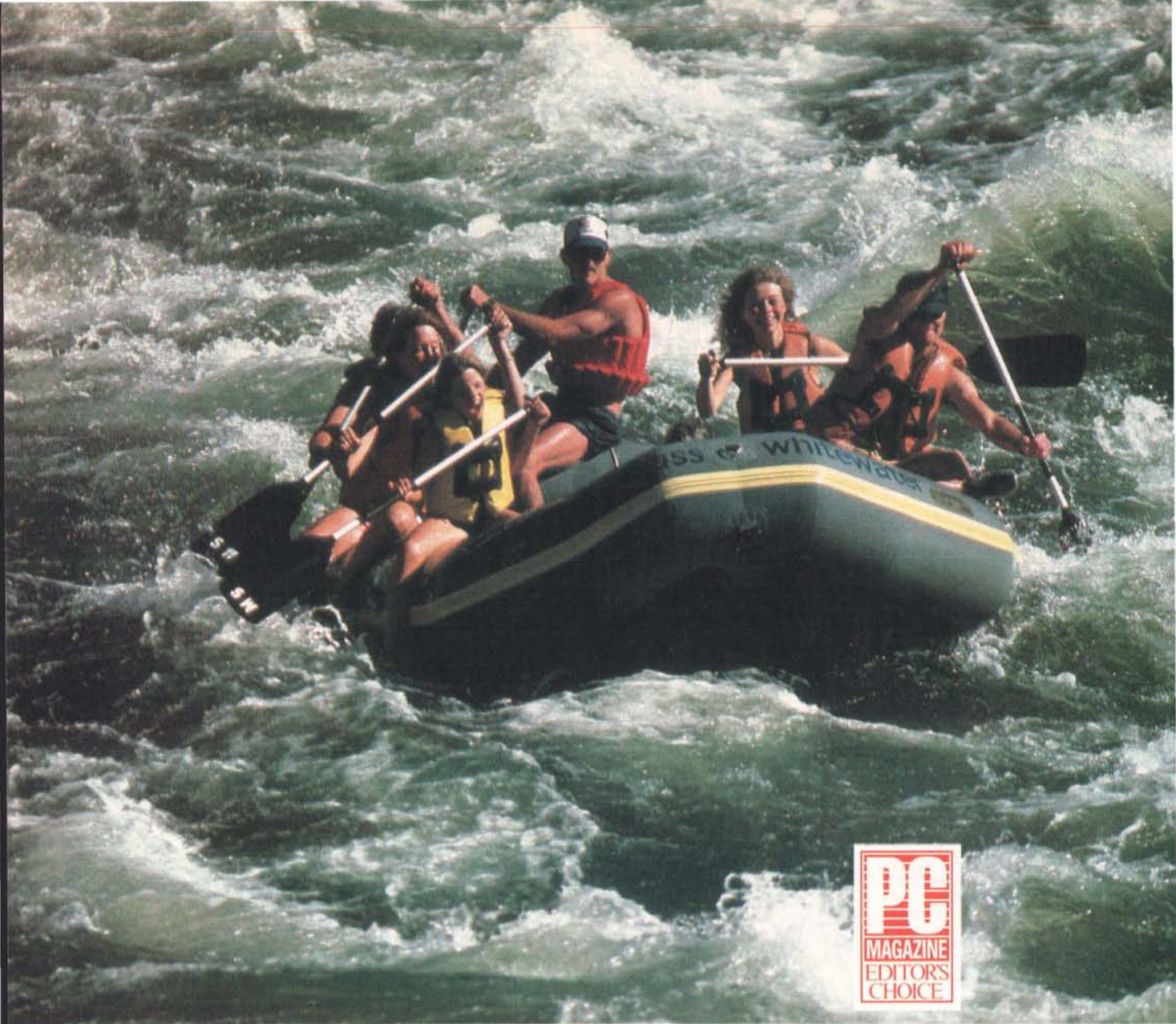

10NET Turns Your Work Group Into A Work Team

Networking your work group can be as challenging as white water rafting. Conquering a raging river requires good teamwork, too. Let 10NET turn your work group into a work team. The 10NET LAN comes with a raft of features designed to help your group work better.

10NET is one of the easiest networks to install and use. It has extensive network communications software to let you interact more effectively with your team. 10NET is also fully DOS compatible, allowing you to use your existing disks and software.

And to help you navigate into the future, 10NET conforms to common networking standards. Fully NETBIOS compatible, 10NET software runs on a variety of StarLAN and Ethernet networks, as well as IBM's Token Ring.

So call now for further information. 1-800-358-1010 or 1-800-782-1010 (OH)

10NET is a registered trademark of Digital Communications Associates, Inc. IBM is a registered trademark of International Business Machines, Inc.

dca[®]
10NET Communications

7016 Corporate Way • Dayton, Ohio 45459-4223

T800 and Counting

*The T800 transputer and the Occam language
are a hardware/software team designed to work together*

Richard M. Stein

Mankind constantly seeks ways to solve the technological challenges found by observing the natural universe. Today, our understanding of nature is increasingly dependent on computer-based simulation of theories, suppositions, and curiosity.

Such complex operations as verifying the fluid flow of air around the wing section of an airplane to determine drag and stability, studying chemical reactions in the preparation of a new drug, and studying weather patterns require the increases in performance provided by parallel-processing computers. In fact, many problems are beginning to require that increase in speed to quench our growing thirst for immediate responses. As parallel-processing computers become more and more available, these workhorses of science and industry are emerging as a key to continued technological growth.

Multiprocessors vs. Multicomputers
Parallel-processing computers can be divided into two basic architectures: the shared-memory multiprocessor (see figure 1a) and the multicomputer (see fig-

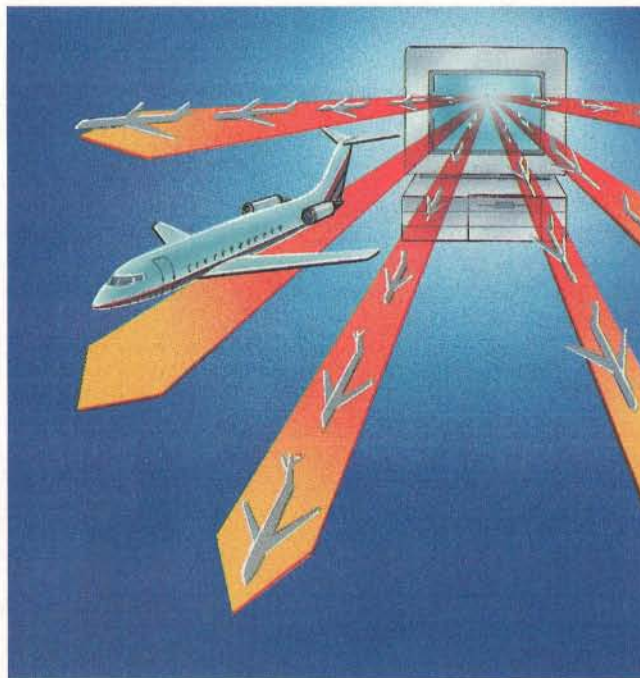

ure 1b). The shared-memory multiprocessor comprises a collection of CPUs connected by a bus to a common pool of memory.

A multiprocessor performs parallel computations in several ways. One is to dedicate a complete processor to each active process; this is called *control parallelism*. Each process is free to operate on memory without appreciable interfer-

ence from the others. Why not add more processors and keep partitioning the problem, one process to each processor, to gain more speed? A problem arises as you add CPUs to the bus: When one CPU tries to access an address in memory, it must first get permission from the others. Arbitration among the CPUs leads to contention. Each CPU requires a finite amount of time to fetch something from memory, and while this is going on, the other CPUs must wait if they need data as well. Adding more CPUs simply makes the problem worse, and a bottleneck results.

This is the so-called von Neumann bottleneck. It's the reason multiprocessors seldom have more than four CPUs simultaneously operating on a common pool of memory. The bus bandwidth is saturated by simultaneous requests from the CPUs. The shared resource leads to a form of inflation, where the cost of performing an operation becomes increasingly expensive and therefore less efficient. This is the key limitation to multiprocessor architectures: Finite bus bandwidth means that only a fixed num-

continued

ber of instructions can be carried out each second. While this may be appreciable—more than 500 million floating-point operations per second (MFLOPS) is possible—the growth rate in the bandwidth is limited by technology.

The multicomputer differs from the multiprocessor in several ways. Processors are not connected to a common bus. Instead, each processor has a small (64K-byte to 4-megabyte) RAM connected to a local bus—the processor and RAM are called a *node*—and communication between processors occurs through high-speed serial links. There is no bottleneck. Since a node doesn't share a common bus with any other node and communication occurs through serial links, the multicomputer's bandwidth rises linearly with the number of nodes.

The multicomputer has other advantages as well. The most notable is cost. Multicomputers require less glue logic and fewer support chips on a per-node basis than do multiprocessors. A multi-

computer typically runs between one-tenth and one-hundredth the cost of a comparable multiprocessor.

The Transputer

About 4 years ago, INMOS introduced the transputer, a multicomputer building block. It has a great cost-performance ratio: A T800 transputer with 4 megabytes of RAM costs about \$1000, and a 30-MHz T800 delivers 2.25 IEEE 32-bit MFLOPS and 15 million instructions per second, well under \$100 per MIPS. In addition, the transputer requires little support circuitry: You can build a fully functional multicomputer node (a transputer, a 5-MHz crystal, a few pull-up resistors and diodes, four F373 parts [octal latches], some RAM, and a wire-wrap tool) in a few hours. The most costly part of the hardware is the RAM.

Figure 2 shows the internal structure of the T800 transputer. This architecture is unique when compared with conventional CPUs. The T800 incorporates 4K

bytes of on-chip static RAM. A program that fits into this on-chip reservoir will execute instructions in the transputer's cycle time—that is, in the 33-nanosecond cycle for the 30-MHz version. The internal RAM is not cache memory per se, as many conventional reduced-instruction-set-computer processors have, but it does serve an important role as stack space.

The internal RAM is used by compilers to hold the base addresses of arrays and local procedure variables. The base address of an array is used far more often than a single array-element address during program execution. The size and type of an array element are fixed at compile time, so a simple calculation can determine the address of any array element. The internal RAM serves as a register stack, an area where variables used repeatedly are held to speed access and program execution. A register variable is accessed in a single cycle, but variables held in external RAM require a handful of cycles to latch and read.

Using the transputer's internal RAM in this way does have one side effect, and it shows up in the language specification for Occam, the transputer's native language. By definition, the Occam language is not recursive. If it were, the repeated stacking of the local variables would generate confusion at each level of recursion during program execution. Stack frame building requires dynamic memory allocation, which Occam does not support. Implementing recursion on the transputer is a bit tricky in Occam, since the application must maintain the stack and you must explicitly manage stack traversal.

The T800 integer-register set is sparse but highly functional (see figure 3). The three accumulators are arranged as a stack and serve as expression evaluators. The workspace pointer tracks the address of the data that the active process is using. The instruction pointer is similar to the program counter found in conventional CPUs and points to the current instruction.

The transputer's operand register serves as the focal point for instruction processing. All transputer instructions are 1 byte long and typically execute in one to two cycles. The transputer forms an operand by loading the instruction data field into the 4 least significant bits of the operand register. The instruction uses the contents of the entire operand register as its operand; it clears the operand register to 0 on completion.

The transputer also performs instruction prefetch. Since each instruction is 1 byte, four will fit into one word on the

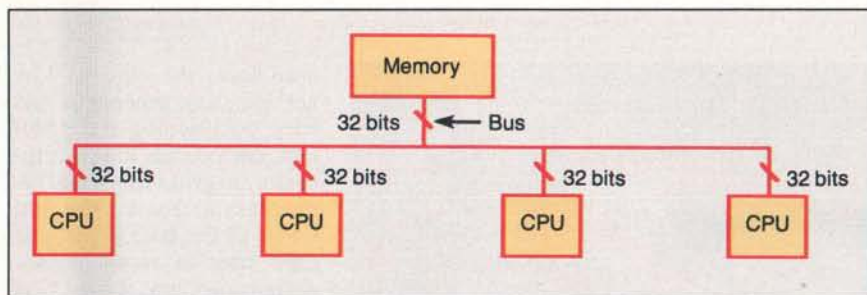

Figure 1a: A typical shared-memory multiprocessor (without contention memory cache). The bus is a common resource among all CPUs; as more CPUs are added, bus contention can lead to the von Neumann bottleneck.

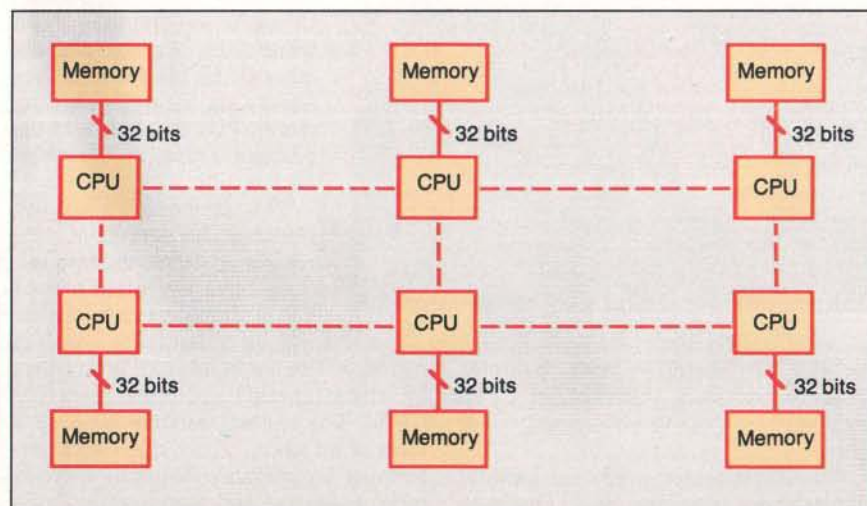

Figure 1b: A typical multicomputer system. Each node consists of a CPU and memory. Processes communicate with each other through bidirectional serial links (dotted lines).

GET BYTE YOUR WAY!

FULL TEXT OF BYTE ON DISK

Now you can order disks containing the full, machine-searchable text of articles. You can read and search the text with any word processor. Excellent for reference and research! Disks can be ordered singly or by annual subscription.

BEST OF BIX ON DISK

The highlights of each month's activity on BIX—BYTE's world-class online conferencing system. You can read and search the text with any word processor. Each disk contains the most interesting and informative recent discussions specific to the machine you own. For example, order the IBM disk, and get the highlights from IBM-specific conferences. Disks can be ordered singly or by annual subscription.

LISTINGS ON DISK BYTE listings on disk are right for you if you want to compile or read programs quickly.

LISTINGS IN PRINT

Printed and bound versions of the complete source code listings of programs mentioned in our articles. Handy for quick reference. Order singly or by annual subscription; with or without accompanying diskette version (see above).

**FOR DIRECT ORDERING
CALL TOLL FREE:
800-258-5485**



**Call: M-F, 8:30 a.m. to
4:30 p.m. Eastern Time**

**(603-924-9281 for New
Hampshire residents)**

**For credit card
orders only.**

ON DISK

Available on disk: BYTE listings available from December 1985 to present at the prices stated at right. Full-text of BYTE available from September 1988 and Best of BIX available from November 1987. Please mark the appropriate format and choices and note the issue date below. If you are ordering a subscription, please note the issue date on which you would like it to begin.

Month _____

Year _____

	IN USA:		OUTSIDE USA:	
	Single Month (one disk)	Annual Subscription (13 disks)	Single Month (one disk)	Annual Subscription (13 disks)
5 1/4 inch: <input type="checkbox"/> IBM PC (For information on other available disk formats call the 800 number below.)	<input type="checkbox"/> Full text of BYTE \$9.95 <input type="checkbox"/> Best of BIX \$9.95 <input type="checkbox"/> BYTE Listings only \$9.95	<input type="checkbox"/> Full text of BYTE \$79.95 <input type="checkbox"/> Best of BIX \$79.95 <input type="checkbox"/> BYTE Listings only \$9.95	<input type="checkbox"/> Full text of BYTE \$12.95 <input type="checkbox"/> Best of BIX \$12.95 <input type="checkbox"/> BYTE Listings only \$12.95	<input type="checkbox"/> Full text of BYTE \$99.95 <input type="checkbox"/> Best of BIX \$99.95 <input type="checkbox"/> BYTE Listings only \$99.95
3 1/2 inch: <input type="checkbox"/> Apple Macintosh <input type="checkbox"/> Atari ST <input type="checkbox"/> Amiga <input type="checkbox"/> IBM PS/2	<input type="checkbox"/> \$10.95	<input type="checkbox"/> \$89.95 (Save \$62.40)	<input type="checkbox"/> \$13.95	<input type="checkbox"/> \$109.95 (Save \$71.40)

IN PRINT

1988 Supplement Issues

- January through March 1988
\$7.95 in USA
\$12.95 outside USA

Monthly supplements replace quarterly supplements starting in April. Indicate the month you're ordering in the space below.

Month _____

Year _____

\$3.50 per issue in USA
\$4.50 per issue outside USA

Annual Subscriptions:
\$20.00 in USA
\$35.00 outside USA

Please note month and year you would like the subscription to begin.

Month _____

Year _____

1987 Supplement Issues

IN USA:

- January through March 1987 for only \$7.95.
 April through June 1987 for only \$7.95. (Includes 1986 Index).
 July through September 1987 for only \$7.95.
 October through December 1987 for only \$7.95.
 1987 subscription only \$19.00.

OUTSIDE USA:

- January through March 1987 for only \$8.95.
 April through June 1987 for only \$8.95.
 July through September 1987 for only \$8.95.
 October through December 1987 for only \$8.95.
 1987 subscription only \$22.00.

1986 Supplement Issues

IN USA:

- January through June 1986 for only \$9.95.
 July through September 1986 for only \$9.95.
 October through December 1986 for only \$9.95.
 1986 Annual Subscription for only \$19.00.

OUTSIDE USA:

- January through June for only \$10.95.
 July through September for only \$10.95.
 October through December for only \$10.95.
 1986 Annual Subscription for only \$22.00.

COMBINED DISK AND PRINT SUBSCRIPTION

Bundled together, giving you the convenience of disk-based source-code plus the ease of reference of print.

If you are ordering a subscription, please note the issue date on which you would like it to begin.

	IN USA:	OUTSIDE USA:
	Annual Subscription	Annual Subscription
5 1/4 inch: <input type="checkbox"/> IBM PC (For information on other available disk formats call the 800 number below.)	<input type="checkbox"/> \$99.95 (Save \$74.90)	<input type="checkbox"/> \$119.95 (Save \$106.90)
3 1/2 inch: <input type="checkbox"/> Apple Macintosh <input type="checkbox"/> Atari ST <input type="checkbox"/> Amiga <input type="checkbox"/> IBM PS/2	<input type="checkbox"/> \$109.95 (Save \$77.90)	<input type="checkbox"/> \$129.95 (Save \$109.90)

Please complete in full.

NOVEMBER

Name _____

Address _____

City _____ State _____ Zip _____

County or Parish _____ Country _____

Credit Card # _____

Exp. Date _____ Signature _____ Date _____

Check enclosed

MasterCard

VISA

U.S. Funds enclosed (If ordering from outside the U.S. please remit in U.S. funds drawn on a U.S. bank. Thank you.)

Please allow 4-8 weeks for delivery.

BYTE



FOLD
HERE



NO POSTAGE
NECESSARY
IF MAILED
IN THE
UNITED STATES

BUSINESS REPLY MAIL
FIRST CLASS MAIL PERMIT NO. 10 PETERBOROUGH, NH

POSTAGE WILL BE PAID BY ADDRESSEE

BYTE Listings

One Phoenix Mill Lane
Peterborough, NH 03458-9990



FOLD
HERE

T800. Each instruction fetch retrieves four instructions simultaneously; this requires less frequent accesses to memory. The transputer maintains a double-buffered instruction queue. The prefetch-and-buffering scheme delivers most of the performance benefits of an instruction cache, but without the silicon's cost. The prefetch-and-buffering sequence almost completely decouples instruction execution time from memory speed.

The transputer is designed to execute concurrent processes under direct hardware control. A by-product of hardware process scheduling is realized in the extraordinarily short context switches. Due to a hardware stack maintained by transputer microcode, most context switches require only between 1 and 2.5 microseconds (μs). A transputer process consists of a local workspace and a small reserved area for linkage information, which holds the pointers used to maintain multitasking and I/O protocols.

The hardware scheduler supports two process priorities: high and low. It gives the high-priority process unconditional control over the CPU and prevents the low-priority processes from executing until the high-priority one relinquishes the CPU. You use a high-priority process for very short—less than one time slice—sequences of instructions that are not to be interrupted by external events or bumped by other processes. The time-slice period is approximately 1 millisecond for a low-priority process. All low-priority processes execute asynchronously. This asynchronous execution scheme is an important concept for multicomputer software systems.

The transputer has an on-board hardware timer, which can be used to obtain synchronous interrupts for time-critical processes. The timer derives its signals from the externally connected 5-MHz crystal. The crystal supplies the transputer's phase-lock loop with the synchronization signal coordinating all the internal mechanisms. The timer is accessed through a channel assignment, and it has either 1- μs or 64- μs resolution. With these clock intervals, you can schedule processes tightly to execute at precise intervals.

The T800's floating-point unit conforms to IEEE standard 754-1985. At 30 MHz, it is 50 percent faster than a 16-MHz 80386/80387 combination. The T800 performs 32-bit floating-point multiplication, addition, and subtraction in less than 1 μs , and it requires just over 1 μs for division. The transputer's FPU can run in parallel with the integer CPU,

continued

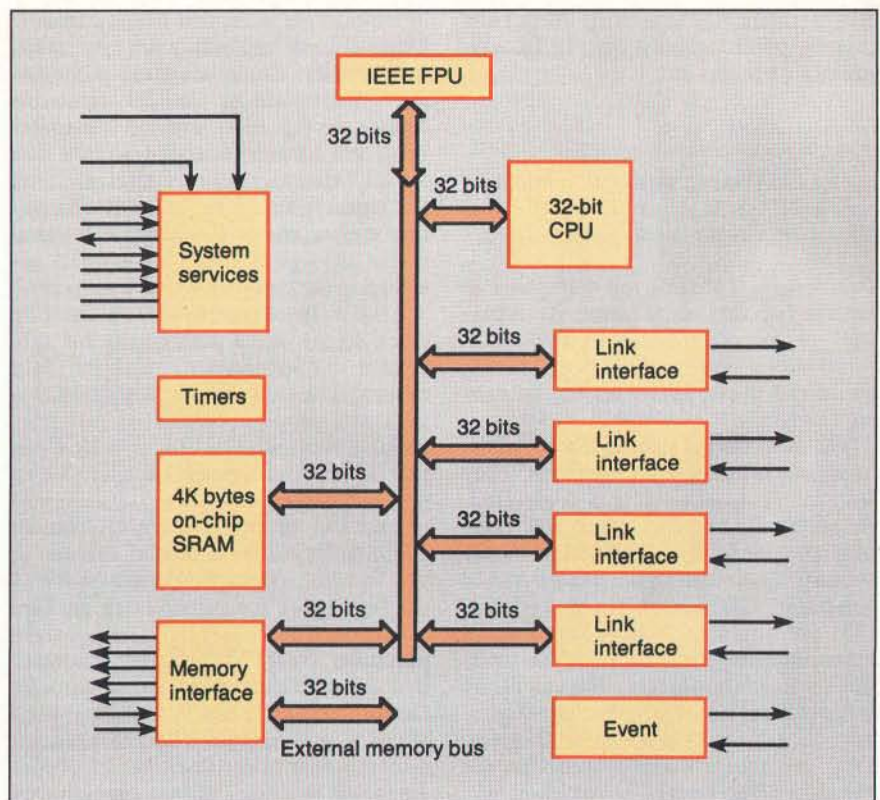

Figure 2: The INMOS T800 transputer. The CPU and FPU can execute in parallel by organizing Occam to exploit both processors simultaneously. The chip is designed for concurrency.

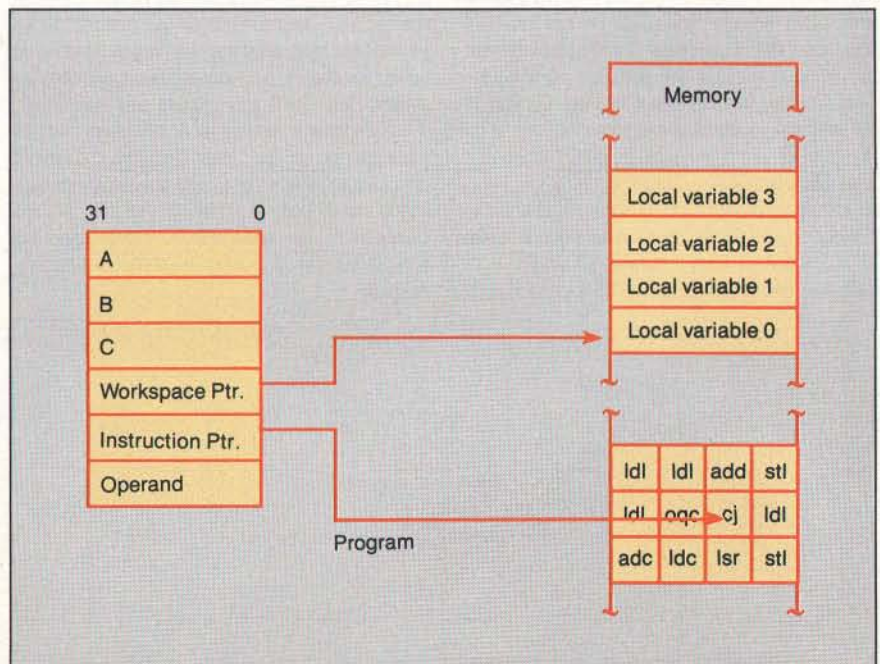

Figure 3: The T800 integer CPU has three accumulators, registers A, B, and C, arranged as a stack for expression evaluation. Zero-address instructions operate on values in the stack; single-address instructions load values from memory into the stack, and so on.

programmatically separating integer and floating-point computations. In Occam, you can write this as

```
PAR
  SEQ
    ...do floating-point calculations
  SEQ
    ...do integer calculations
```

This fragment directs the transputer to execute two sequential processes in parallel, or concurrently: One process executes only floating-point instructions, while the other performs the integer arithmetic.

The most distinguishing feature of the transputer is its four link interfaces. They are direct-memory-access-controlled, bidirectional, serial-transmission links and can operate at up to 30 megabits per second. Therefore, each transputer is capable of 120-megabit-per-second link I/O, the equivalent throughput of 12 Ethernets. The links serve as the interface to other transputers. You can easily connect them into a variety of topologies, such as hypercubes, rings, and grids. They are the primary reason that the transputer is so linear.

The transputer is linear in the sense that if you execute a program on a single transputer, gather some performance data, and then partition the software to run on two transputers, the performance will have nearly doubled. In ray-tracing studies, the transputer's improvement factor is typically 98 percent to 99 percent linear (multiprocessors are typically 70 percent to 80 percent linear).

The Occam Language

In Occam, communicating processes exchange data through a construct known as a *channel*. An Occam channel is a one-way point-to-point pathway resident

in memory; it is termed a *soft channel*. Channel input and output are special for two reasons: Communicating processes are synchronized by channel communication (see figure 4), and the transputer links are memory-mapped so you can "place" channels at link addresses. This placement transforms the soft channel into a *hard channel*, and data is transferred through a link to a process attached to the link on another transputer.

Link input and output share a common clock signal (not a prerequisite for successful communication), and the data transmissions are self-synchronizing. Inputs and outputs can occur simultaneously over the same link, provided that two separate processes are available to both send and receive data.

Link I/O, or, more generally, channel communication, is a pivotal feature of the Occam language. Occam provides the framework for constructing parallel processes (processes with concurrent execution contexts). Parallel processes that communicate must do so through Occam channels, not via shared variables. Why does Occam have this restriction? Because of deadlock, which occurs when two processes fail to communicate correctly as a result of improper coding or design.

Listing 1 illustrates deadlock. The two SEQ processes execute simultaneously; the first requests input on chan2, while the second requests input on chan1. Both processes are waiting for input that will never occur, since no output executes in either SEQ until the inputs are satisfied. The program never reaches the output statements in the SEQs and thus doesn't complete. If you reversed the order of one input and output, the program would complete, because each input request would be satisfied by a complementary output.

Attempting to share a variable among parallel processes gives rise to a similar conflict: One process may try to write the variable at the same time another one is trying to read it. Since parallel processes run asynchronously (at their own rate), reading a variable that has been modified by another process means the value would be uncertain. Since you can't know when the variable will be modified, you could be trying to read it when another process is writing it. To prevent this collision, Occam precludes parallel processes from sharing variables. But Occam variables can and do store data, and channels are available for interprocess communication.

The point-to-point nature of the Occam channel discourages the design of a program dependent on routing data through intermediate nodes. While "through-routing" is typically implemented on the transputer as a separate software process that enqueues and dequeues packets, the hardware provides an easier approach. (Second-generation transputers are likely to have this feature.) You can't always achieve a logically concurrent description that isolates communication dependency to a nearest neighbor. Through-routing circumvents this design limitation, and it's much faster in hardware than in software.

Several manufacturers have developed transputer plug-in boards for both the IBM PC and the Macintosh. CSA, MicroWay, and Definicon Systems all build plug-in PC boards with varying amounts of RAM, transputers, crossbar switches, and price. Nth Graphics manufactures a transputer-based PC plug-in graphics engine running the Hoops graphics package from Ithaca Software. A typical single transputer board with a 20-MHz T800 and 2 megabytes of exter-

continued

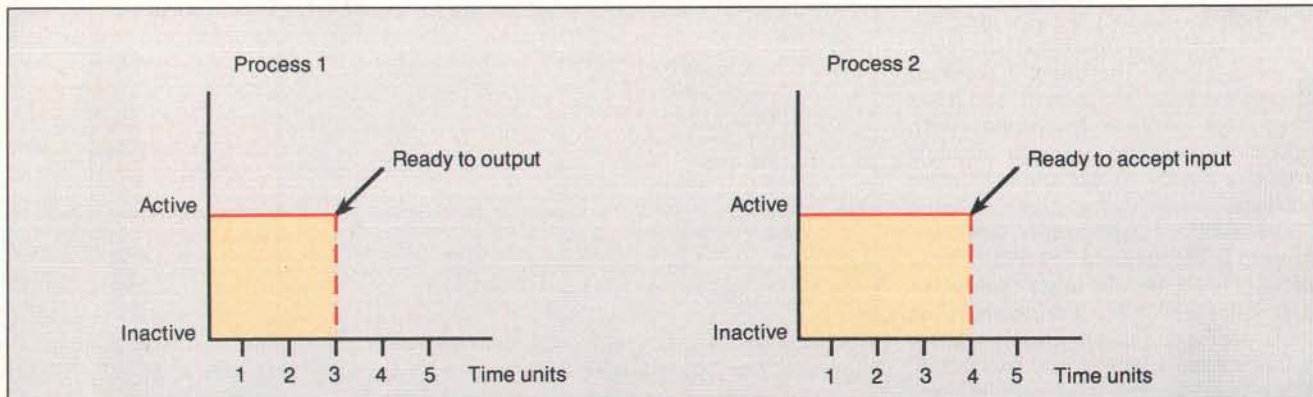

Figure 4: When process 1 must wait for one time unit before process 2 is ready to accept its data, it is said to be "blocked." Processes synchronize only when they communicate via Occam channels.

20MByte XL
now just \$329.
Suggested retail price.



Preserve the fruits of your labor.

You have valuable information on your computer system that demands protection—client lists, sales records, inventory lists, legal contracts, financial records.

Archive Your Data.

Preserve your vital data by creating your own personal archive. The Archive tape backup system is your solution.

The Archive Streaming Tape Solution.

Archive streaming tape systems are easy to add-on and are fully compatible with your IBM PC, XT, AT and compatibles. And all models of the IBM PS/2 family. Both 3½ and 5¼-inch form factor products can be installed directly in your computer cabinet. Or simply connect our

free-standing, self-contained external unit.

Software Completes the Solution!

Archive can preserve 10, 20, 40 MB and more of your data in minutes. Thanks to Archive's own menu driven, auto-prompting QICstream software.

And with over 1 million drives shipped, our leadership position is unequalled in the industry. Archive provides you with the lowest cost—most reliable—advanced technological products on the market today!

Preserve the fruits of your labor. Call now: 1-800-237-4929 for the Archive dealer nearest you. And tell them you want the **Archive Streaming Tape Solution.**



ARCHIVE®

CORPORATION

Circle 30 on Reader Service Card
(DEALERS: 31)

See us at COMDEX booth #1042

nal dynamic RAM costs about \$3000, including an Occam compiler, documentation, and some utilities. Levco makes a plug-in transputer board for the Mac.

Occam is a secure language with a robust and efficient compiler, but it does have some shortcomings. For one, Occam fails to provide hierarchical data-structure typing, an essential for object-oriented programming. You need to have a means of abstracting the problem domain into more than just assignments, inputs, and outputs. The success of a computer model is often characterized by the correctness of the problem-domain abstraction; this is far more easily achieved in languages like Ada, C, and C++. Occam doesn't support the struct syntax of C, enumeration, or dynamic memory allocation. It also doesn't support a recursive syntax, so the application program must stack and unstack recursive data structures like binary trees and linked lists.

C, FORTRAN, and Pascal compilers are available for the transputer. An Ada language compiler from Alsys is planned for August 1989, and rumor has it that Glockenspiel, Ltd., in Dublin, Ireland, is working on a C++ compiler based on the 3L Parallel C compiler. Software tools for the transputer are becoming more widespread.

Logical Concurrency

Logical concurrency is a natural part of any problem domain composed of multiple degrees of freedom. Any system you can view as a collection of processes is said to possess logical concurrency. A formal definition states that the amount of logical concurrency is equal to the number of simultaneous processes or composite coincidental actions occurring in a closed system modeled by a computer program or simulation.

This definition applies to multicomputers. In multicomputer systems, you

gain speed by partitioning the processes among different processors that perform work concurrently. Multicomputers excel in applications where the problem domain possesses data parallelism. You can process a large quantity of data when many nodes simultaneously operate on small, independent parts of the database.

It's customary to classify logical concurrency in terms of granularity. For instance, say a balloon filled with a gas contains 10^{23} molecules. If you attempt to model the equations of motion for each molecule—no small undertaking—you would need a fine-grained logically concurrent description of the problem (see figure 5). However, if you treat the balloon as a composite of 1024 volume elements (and compute an average value for some observable quantity, such as the temperature or pressure in each element), you would consider a medium-grained logically concurrent model. Even fewer volume elements would lead to a coarse-grained logically concurrent description.

Identifying the composite processes of a system is the first, but not the only, step when deriving multicomputer software architectures (see figure 6). Not only must we know *what* the composite processes are, but more important, we must know *how* they interact. Determining the interfaces between the processes is the next most important step.

The interfaces between the processes define the precise format for information exchange. Process A needs input from process B, which might consist of a stream of real numbers, an interrupt, or a binary-encoded number. The interfaces between processes resemble somewhat the argument specifications for a subroutine, function, or procedure.

The inputs and outputs mark the entry and exit points for intermediate results generated by a simulation. They are point-to-point communication paths between processes. If the inputs and outputs are defined, the processes are isolated from each other, and the logically concurrent description of the system is complete. A concise interface definition between communicating processes is essential to executing the transformation from logical to physical concurrency.

The process of designing a multicomputer system begins with the idea to be studied, the environment to be simulated, or the problem to be analyzed, not with the selection of a hardware host. This somewhat radical idea—organizing the software through a logically concurrent description without considering a

continued

Listing 1: This code illustrates deadlock. Two SEQ processes execute simultaneously. Both request input and wait for it, while neither performs any output first. The program hangs.

```

CHAN OF INT chan1, chan2 :-- channel declarations
PAR
INT A :                -- local variable scope is
                        -- the first SEQ
SEQ
chan2 ?                -- input into A on chan2
chan1 ! 6              -- output 6 on chan1
INT B :                -- local variable scope is
                        -- the second SEQ (not shared)
SEQ
chan1 ? B              -- input on chan1 into B
chan2 ! 9              -- output a 9 on chan2
    
```

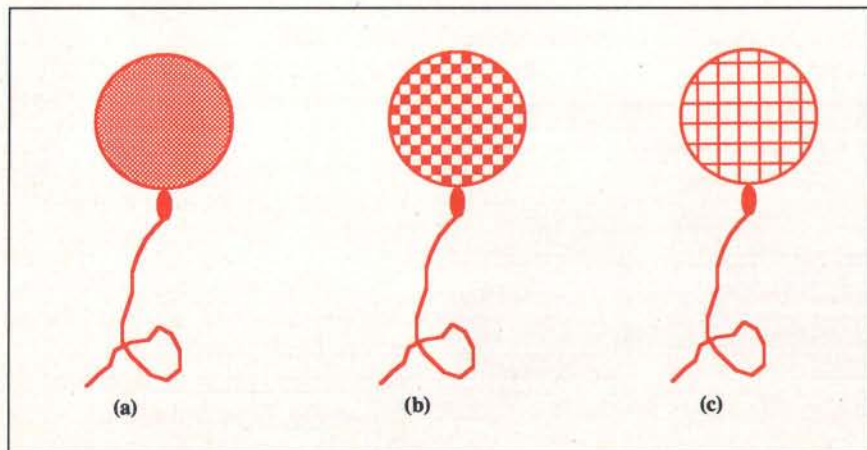

Figure 5: Treating the molecules in a gas as individual and unique leads to a fine-grained logically concurrent description (a), while grouping the gas into small but finite volumes leads to successively coarser descriptions (b) and (c).

HOW TO AVOID A STROKE!



Press 1 Key To Run 10,000 Programs

PowerMenu becomes your friendly interface to your computer. No more changing directories and then typing out a program command to run your program. With PowerMenu, you press a single key to run your program. When you exit your program, you're taken directly back to PowerMenu again.

Reduces User Support Requirement. Virtually Goof-Proof

Most of our Corporate Users have adopted PowerMenu as standard issue on their hard disks based personal computers. They've found that PowerMenu significantly reduces the amount of technical support required by users.

PowerMenu features detailed context-sensitive help and is intuitive to use. Access to "raw DOS" can be restricted by a supervisor.

Security Built-In

PowerMenu has built-in file and program security. Programs can be password-protected. Files can be protected against accidental erasure, and can be hidden from view completely if you wish.

Built In File Manager

PowerMenu is not just "another menu" program. It's simply the best user interface and file manager around. You can easily view your directory and file structure, copy, rename, move or erase files at the press of a key, without learning "computerese" or DOS commands. Multiple files can be "tagged" for copy, erase and/or move in a single pass.

Compare For Yourself. You Can Try PowerMenu For FREE!



PowerMenu Is Just \$89.95

(\$7.50 shipping & handling
CA residents add sales tax)

TO ORDER CALL

800 523-0764

In California, call (408) 559-4545.

OR MAIL CHECK TO

Brown Bag Software
File #41719, Box 60000
San Francisco, CA 94160-1719



PowerMenu Product Feature Comparison

Features	PowerMenu™	AutoMenu™	Xtree™	XTreePro™
Context-Sensitive Help	Yes	No	No	No
Easy Instant Menu				
Editing	Yes	No	No Menus	No Menus
Colorful, Pop-Up Menus	Yes	No	No Menus	No Menus
Runs 10,000 Programs				
with single key	Yes	No	No Menus	No Menus
User-Selectable Colors	Yes	No	No	Yes
File Manager	Yes	No	Yes	Yes
Password Protection	Yes	Yes	No	No
RAM Impact	3K	59K	78K	64K
User-Definable Help	Yes	No	No	No
Resident Program Map	Yes	No	No	No
List Price	89.95	50.00	69.95	129.95
Available in ShareWare	Yes	Yes	No	No

XTree™ and XTreePro™ are trademarks of Executive Systems;
AutoMenu™ is a trademark of Magee Enterprises.

BROWN BAG
Software

State Of The Smart

Offices in London 01 831 1106 Köln 0221 7710923 Copenhagen 01 933837 Amsterdam 020 233408 Zürich 01 2146224
Copyright 1988 Brown Bag Software, Campbell, CA 95008

hardware target for development—is unique to multicomputer software systems.

The end of the design process leads to the construction of a special-purpose computer explicitly organized to execute the software. “Special-purpose” means that the logically concurrent software description, including inputs, outputs, and processes, can now be ported to the physical concurrency of the multicomputer without affecting the software’s design or the schedule.

Logical concurrency is used to abstract problem domains into software

multicomputer solutions in conjunction with the transputer and Occam: a hardware-and-software team created to facilitate the logical-to-physical transformation.

Transformation Revealed

The transformation from logical concurrency to physical concurrency is the crux of multicomputer development. The speed increase in the algorithms and software is a direct result of this transformation. The entire process of designing transputer-based multicomputer software begins with this assumption: Once

you have a logically concurrent description, you can evaluate the software’s behavior on a single transputer using soft channels to transfer data between cooperating processes.

This single-transputer implementation is necessary for two reasons: It is unlikely that a “shotgunned” multicomputer software-development cycle (where you “hack” the software out and distribute it among all the nodes) will be successful, and debugging a single-transputer implementation, or any uniprocessor implementation, is easier than debugging software on several processors at once.

The path to physical concurrency starts with observing the logical behavior of the simulation running on a single transputer. The CHAN declarations are the key to performing the mapping. The logical software model, composed of several communicating processes, uses the channels to pass messages. Occam places these channels into the single transputer’s address space.

The desire, however, is to achieve physical concurrency, which is accomplished when the logical software model is distributed among the processors according to the software design. With the Occam PLACE construct, you can map the channel addresses to the link addresses. The PLACE construct instructs the compiler to set the address of the predicate at a specific address. For example, the statements

```
INT abcd :
PLACE abcd at #4 :
```

cause the integer variable *abcd* to be placed at address 4 (hexadecimal).

Likewise, the PLACE construct applies to channels. The transputer’s address space has eight specific addresses for the links, and once you PLACE a channel there, it’s called a hard channel, instead of a soft channel for memory-to-memory channel I/O. This hard channel then writes or reads information from another process resident on another transputer. There are eight link addresses, four for input links and four for output links, designated *link.in0*, *link.out0*, *link.in1*, *link.out1*, and so on.

To complete the logical-to-physical transformation, you must also direct the processes to the appropriate transputer. This task is handled by the INMOS configurator, a postcompilation operation that determines a boot path, along which all the processes will flow toward their target destinations. An example of a tem-

continued

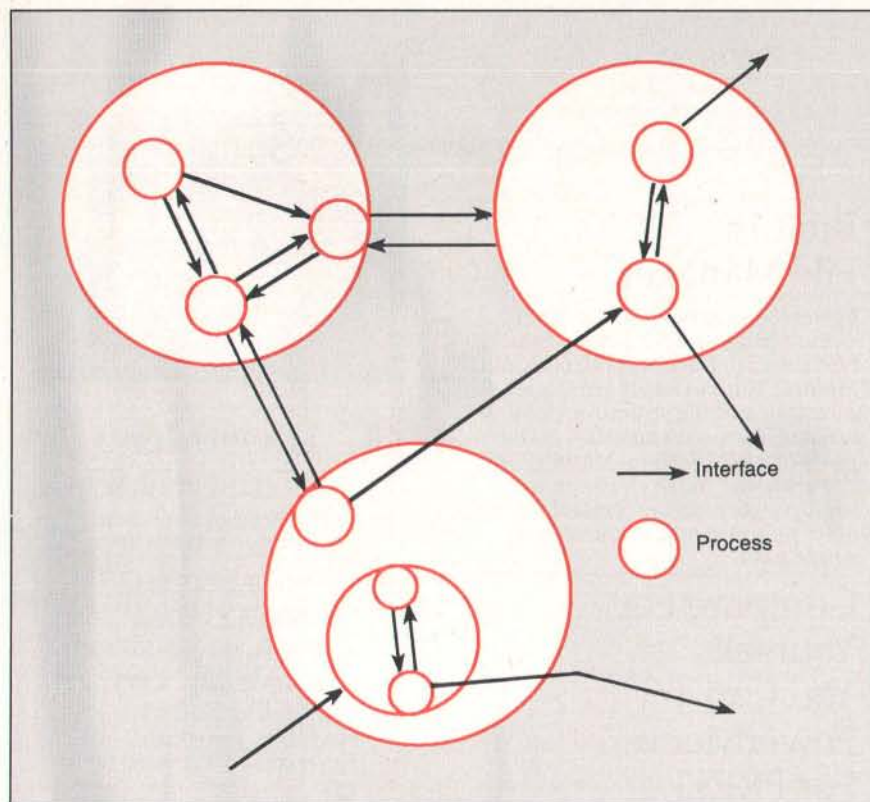
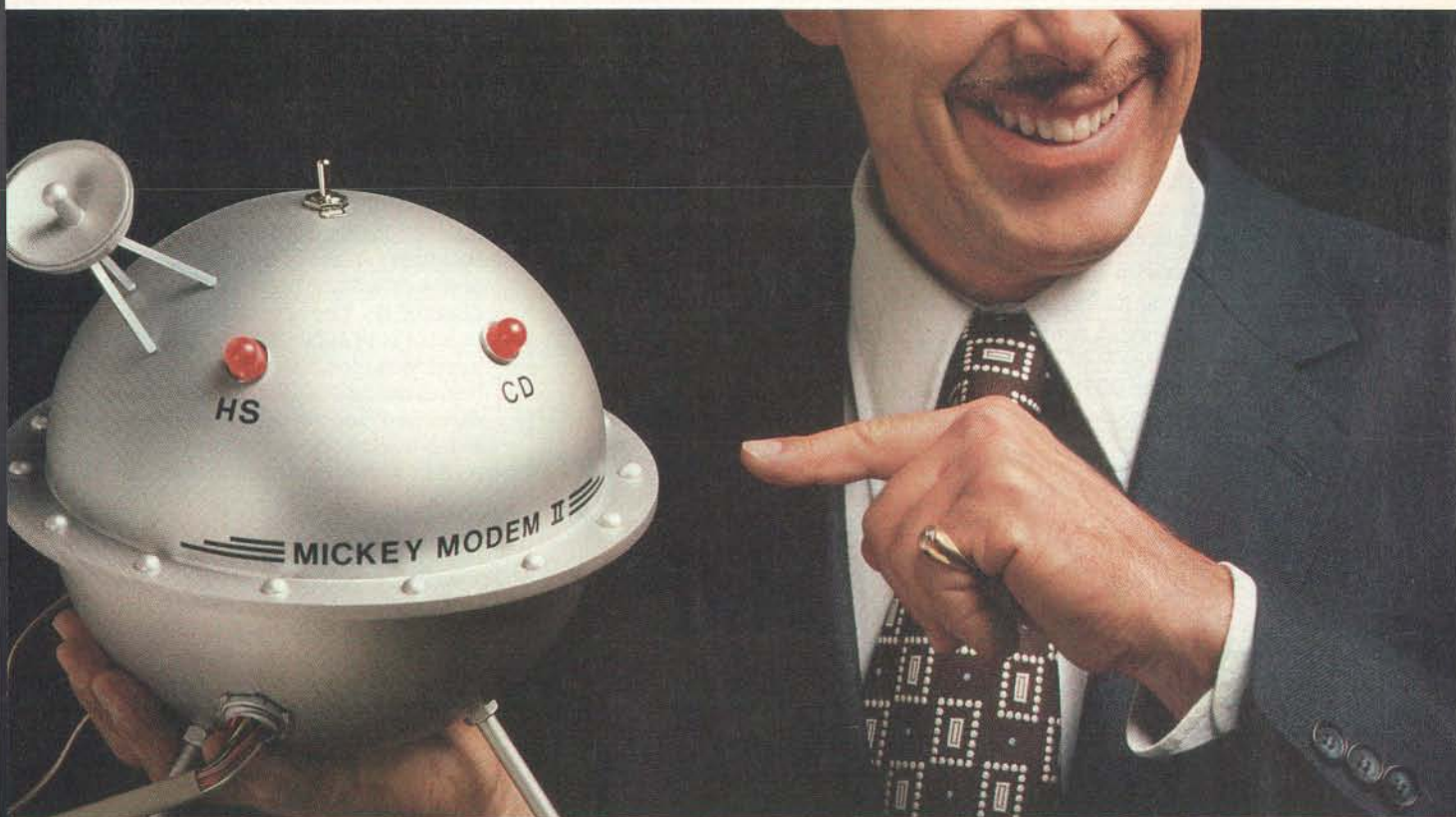

Figure 6: A process-structure graph. Identifying the composite processes in a multicomputer system is important, but so is isolating the interfaces between processes.

Listing 2: A template program. This can serve as input to the configurator.

```
PLACE chan0.out AT link0.out :
    -- put chan0.out at hard link0.out
PLACE chan0.in AT link0.in :
    -- put chan1.in at hard link0.in
PAR
PROCESSOR 0 T8    -- processor 1 is a T800
navier.stokes()  -- solve the Navier-Stokes equations
PROCESSOR 1 T8    -- processor 2 is also a T800
graphics.output() -- dump the output (in real time)
:
```



DON'T CONFUSE BUYING AN INEXPENSIVE MODEM WITH SAVING MONEY.

You can buy modems that cost less than the Hayes Smartmodem 1200™ or Smartmodem 2400™, but what will you get?

Will you get a modem like the Smartmodem 1200 that is tested and inspected over 20 times and offers the most comprehensive performance warranty in the business?

Will you get a modem like the Smartmodem 2400 that has Hayes AutoSync for built-in synchronous capability without the extra expense of an adapter card?

Will you get a modem that has software, like the Hayes Smartcom family of software, that's specifically designed to deliver the full functionality of a Hayes modem? No way.

So if you want to save yourself a little something, don't buy a modem whose best feature is its price tag. Buy a Hayes. And save yourself a lot of aggravation.



For your nearest Hayes Advanced Systems Dealer, call 800-635-1225. Hayes Microcomputer Products, Inc., P.O. Box 105203, Atlanta, GA 30348.
© 1988 Hayes Microcomputer Products, Inc.

Hayes.

People are talking about us.

"This is a very good implementation of FORTRAN, better than the one I use on my minicomputer system." *IEEE Software*

"Lahey F77L is definitely for the programmer's market, with features for the casual and professional user...*EDITOR'S CHOICE*" *PC Magazine*

"It is a fantastic product." *PC Australia*

"It should be the last FORTRAN compiler you will need to buy..." *Your Computer*

"Lahey F77L was by far the easiest compiler to use..." *Programmer's Journal*

"Compilation speed is Lahey FORTRAN's most remarkable feature; it is unbelievably fast...Realistically, Lahey FORTRAN is the most efficient and productive FORTRAN development tool for the DOS environment..." *Byte*



When people talk about FORTRAN
the name mentioned most often is

Lahey
Computer Systems Inc.

Contact us to discuss our products and your needs. (800) 548-4778
Lahey Computer Systems, Inc. P.O. Box 6091, Incline Village, NV 89450
Tel: (702) 831-2500 FAX: (702) 831-8123 Tlx: 9102401256

POWER TOOL.

Introducing **4x488™**

You get intelligent
IEEE-488 and RS232
ports to make instru-
ment programming
fast and easy.

You can have up to
4 Mbytes of memory
on the same board for
your largest programs,
RAM disks, and data acquisition tasks.

Compatibility is built-in so you can run your favorite programs
or create new ones with our advanced programming tools.

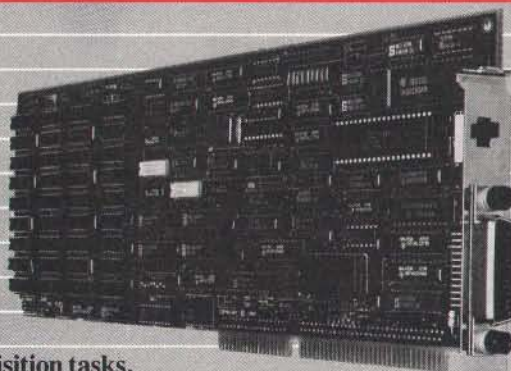

To get your FREE demo disk—call 617-273-1818.
Capital Equipment Corp.
Burlington, MA 01803

cec

The bottom line—IEEE-488, RS232, par. port, 4MB EEM LIM, runs DOS and OS/2.

plate program that can serve as input to the configurator is shown in listing 2.

The configurator generates a complete image with the boot path and bootstrap instructions for each node in the multi-computer. The loader PLACES the processes called `navier.stokes()` on PROCESSOR 0. The `graphics.output()` process is PLACED on PROCESSOR 1. The loader downloads the processes and then begins execution. Communication is synchronized, for the two processes in listing 2 don't know or care whether they read or write from hard channels or soft channels.

Software-Driven

Ideally, a software design should be completely independent of the hardware. The multicomputer system is driven by software, not hardware requirements. However, its success depends on the existence of a suitable hardware host. The INMOS transputer is designed to serve as a multicomputer node.

The innovators and pioneers who elect to invest and pursue multicomputer systems will find an increasing marketplace for this technology. The skills you need to design multicomputer software systems are not radically different from those used in sequential software design. Understanding the Occam language, transputer architecture, and, most of all, logical concurrency are the major requirements. Mostly, however, designing multicomputer software systems depends on creativity, intelligence, and desire. ■

BIBLIOGRAPHY

- Athas, William C., and Charles L. Seitz. "Multicomputers: Message-Passing Concurrent Computers." *IEEE Computer*, vol. 21, no. 8, August 1988, pp. 9-24.
- Heath, M. T., ed. *Hypercube Multiprocessors*. Philadelphia: SIAM, 1987.
- "IMS T800 Architecture." *Technical Note 6*, INMOS Ltd., 1987.
- Mackintosh, Allan. "Dr. Atanasoff's Computer." *Scientific American*, August 1988, pp. 90-96.
- Packer, Jamie. "Exploiting Concurrency: A Ray Tracing Example." *Technical Note 7*, INMOS Ltd., October 1987.
- Pountain, Dick, and David May. "A Tutorial Introduction to Occam Programming." London: Blackwell Scientific Publications, Ltd., 1987.

Richard M. Stein is a software engineer and writer from Irvine, California. He has worked with INMOS transputers for more than 3 years. He can be reached on BIX as "rstein."

NEW...
GoldWorks II™

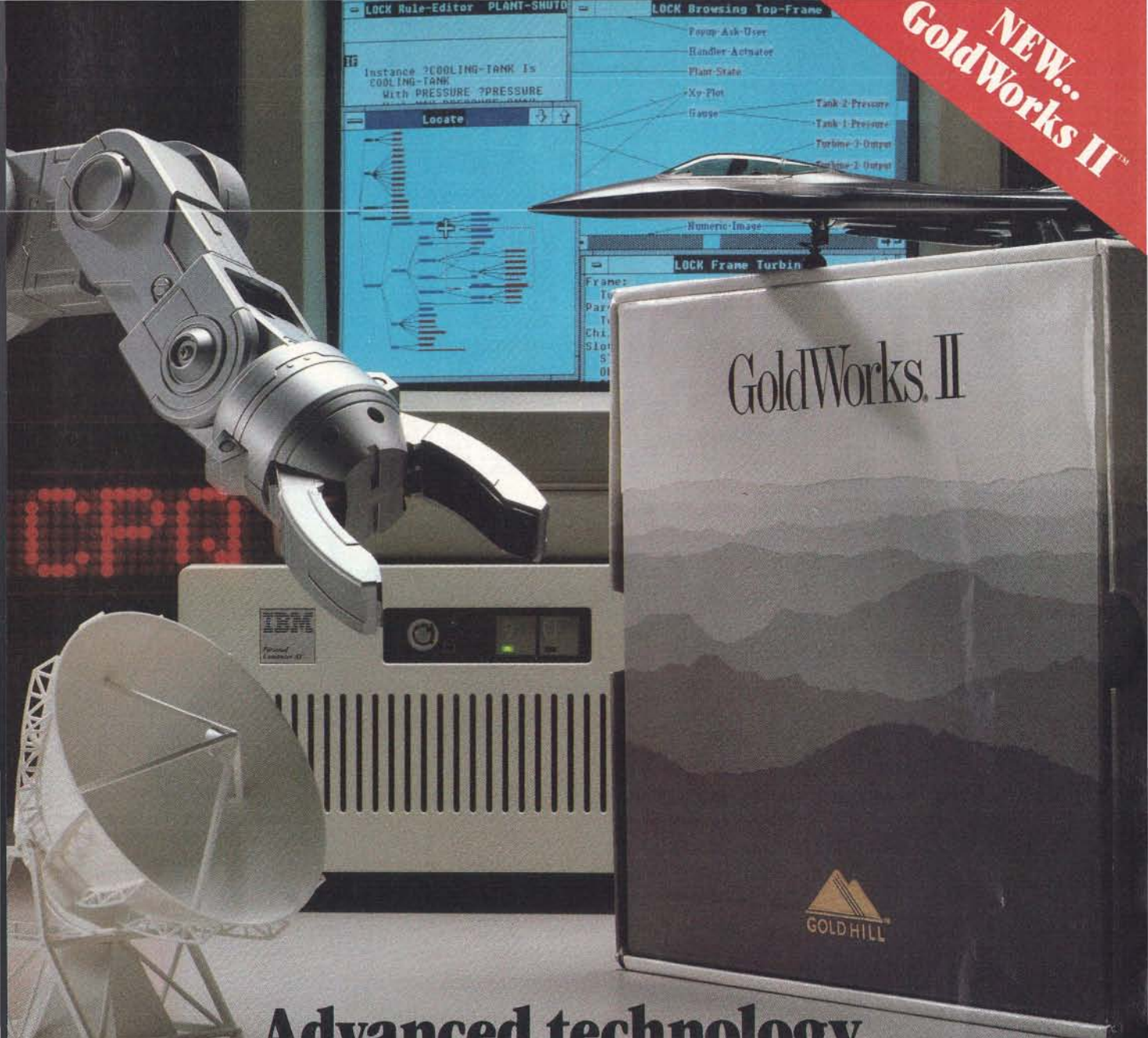

Advanced technology for advanced applications.

The advanced technology of GoldWorks II is designed for the new generation of desktop computer systems. You get the proven performance and high productivity of Gold Hill's leading PC-based expert system development tool—plus dynamic graphics with Microsoft Windows.

So now you can tackle a broad range of knowledge-based problems on your PC class machine. Use the rich graphical environment to build intelligent interfaces. And integrate expert systems with conventional applications, spreadsheets, databases and other programming languages, including "C".

GoldWorks II is one of a family of superior Gold Hill products—including

GoldWorks AXLE, a breakthrough tool that helps accelerate the development cycle, and GoldWorks Runtime, for expert system delivery on PCs. All backed by our uncompromising commitment to excellence in service, education and support.

Whether your expert system is in manufacturing, financial services, electronics, aerospace, or any other application—develop it with the most advanced PC-based development tool available—GoldWorks II.

And GoldWorks II will soon be available on the Sun and Apple Macintosh II.

To learn more, call or write Gold Hill today. And ask for your free copy of the Gold Hill Applications Portfolio. It describes numerous real world AI applications developed by some of our 12,000 users worldwide.

Gold Hill. The expert in AI.

Gold Hill Computers, Inc.
26 Landsdowne Street
Cambridge, MA 02139

Toll-free: 1-800-242-5477
In Mass.: (617) 621-3300



Circle 142 on Reader Service Card

**Our
Bicentennial
is only a
hundred years
away.**

In this, our hundredth year, we pause briefly to celebrate past achievements. And to consider the exciting opportunities ahead.

In the past two decades, the Information Revolution has changed the way people live and work. In that time, a new McGraw-Hill has taken shape.

Today we are a multi-media publisher and information services company, creating a vast array of print, software and on-line information products to meet the changing needs of the markets we serve.

As we look to the future, we see new information technologies emerging and new McGraw-Hill products that use those technologies to the fullest.

In the midst of these continuing developments, however, it is important to remember that the underlying principles that have guided our company for the past century will continue to define us in the next century.

People will always need information.

They will always seek out the authoritative information source.

They will always demand timely information in the format they can work with most easily.

And so our task is clear: in print, on-line, over the air, or even in some as-yet-unimagined forms, McGraw-Hill must continue to stand for information of the best kind ... information that leads to action.



Information that leads to action.

“What do these 24-wire printers have that the others don’t?”



Think the C. Itoh C-815 Supra and the C-715A Reliant can't be much different from the other 24-wire printers on the market?

Look a little closer.

Extra speed.

Both the high-volume C-815 and seven-color C-715A work up impressive presentation quality printing — fast.

How fast? At 570 characters per second in data processing mode, the C-815 Supra with its unique diamond print-head has been clocked as the fastest 24-wire printer you can buy.

And for letter quality printing, the C-715A is no slouch — 100 cps is a good deal faster than most daisy wheel printers.

Extra versatility.

Paper handling has never been better, either. Both printers feature a push/pull tractor for multi-part forms, a short paper tear off, and top, rear, bottom and single-sheet paper feeds.

Some C-815 models will accept up to 9-part forms, and the C-715A will even let you slide in a single sheet without removing your pin-fed paper.

Extra compatibility.

The C-815 and C-715A work with almost any software package on the market. Because Toshiba[®], IBM ProPrinter[®] and Qume[®] emulations are built right into the C-815. And Toshiba, IBM ProPrinter, Diablo[®] and Epson[®] emulations snap into the C-715A with compact identity cards.

All the extras.

You get all the extras on the C. Itoh C-815 and C-715A, including a 12 month warranty, nationwide service centers and C. Itoh's legendary reliability.

So whatever you do, don't decide all 24-wire printers are alike. Until you've seen a C. Itoh.

Call (800) 227-0315 or (714) 757-4492
Southeastern Regional Office (404) 368-9183
Eastern Regional Office (609) 235-3400
Midwestern Regional Office (312) 860-7770
Western Regional Office (714) 757-4422

C. ITOH
C. Itoh Electronics, Inc.

2505 McCabe Way, Irvine, CA 92714

We build more in. So you get more out.

Getting the Job Done

"Linda," a parallel-programming language, is easy, efficient, and portable

David Gelernter

Parallelism is a demonstrated success at making programs run faster. It is a conceptual model of tantalizing potential. Parallel machines are rolling off more company assembly lines all the time. Parallelism, most observers agree, can revolutionize computing, from supercomputers to workstations. At the workstation level, the implications might be even more exciting than they are for supercomputing. But there is a problem.

What's the Problem?

How do you program a parallel machine? If the industry can't come up with an answer that works for lots of programmers and lots of applications on lots of machines, parallelism will survive only at the supercomputer level, and it won't thrive even there.

A parallel machine consists of many subcomputers that can focus simultaneously on the same problem. To use a parallel machine, we need programs that do many things at once. It's usually not difficult to understand how to break a program down into a collection of parallel tasks. A simple analogy: If you understand how to build a house, you can

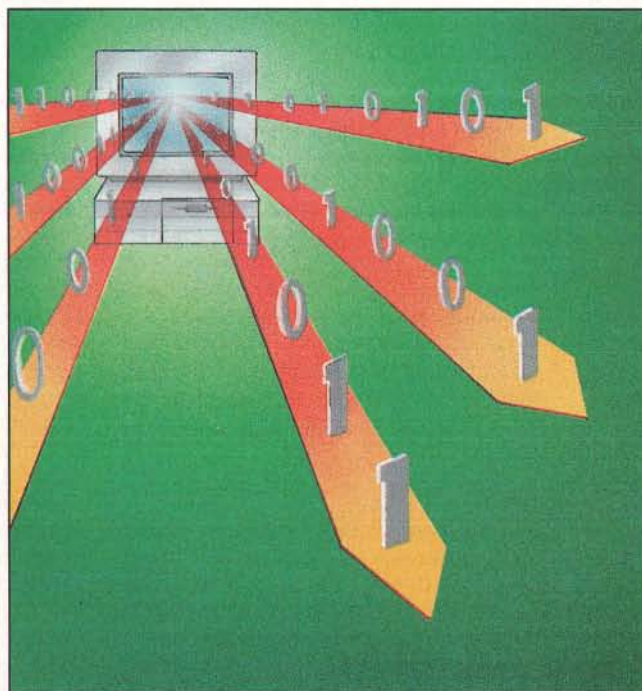

imagine attempting the job all by yourself, but you can also picture 2 people working on it simultaneously, or 10, or 100. Parallelism in such cases is a simple and obvious strategy for getting the job done. The software problem is similar. If you understand what a program does, it's usually not hard to imagine how a group of "workers" (a parallel machine) could do the job faster than one.

In software development, breaking a program into tasks isn't usually difficult. The hard part is putting them back together again into a coherent whole. Although I may understand, abstractly, that a certain group of tasks can be performed simultaneously, C, Lisp, FORTRAN, BASIC, Pascal, Prolog, and other conventional "sequential" languages provide no tools for creating parallel tasks and coordinating their activities. Sequential languages lack the necessary adjectives and verbs. Programmers need new tools—either new programming languages, new dialects of old languages, or run-time libraries of system-level routines—to write parallel programs.

In my research group at Yale, we believe that settling on and delivering the right set

of new programming tools is the central bottleneck in parallel software development. The right set, we believe, will meet three major requirements: *portability*, *efficiency*, and above all, *ease of use*.

We have developed a system called Linda that demonstrably meets these requirements. It has been implemented on a wide range of parallel machines and

continued

used to program a diverse set of applications, including numerical problems like matrix multiplication, LU decomposition and linear programming, parallel string comparison, database search, circuit simulation, ray tracing, expert monitors, parameter-sensitivity analysis, charged-particle transport, and others.

Linda meets our abstract requirements and seems to be working out in practice. Another aspect to the system, harder to explain but still important, moves Professor Kenneth Birman, a distributed-systems expert at Cornell, to call Linda "the most elegant piece of work in the area." Linda is a practical system; it is also an attractive and evocative thought tool. We're using it to parallelize existing software and to develop new program structures in which parallelism plays a central *conceptual* role in making complex, heterogeneous tasks manageable.

Nonnegotiable Demands

- *Portability.* An enormous range of parallel machines is available. You can't be expected to rewrite your applications whenever you move from one to another. In addition, any network of autonomous computers is itself, potentially, a parallel machine. For example, I may choose to port my program from a parallel workstation to a large, shared parallel computer and then to an entire network of machines. Allowing for some inevitable tuning when moving between grossly different hardware setups, we insist that *one* parallel language be appropriate at all three levels.

- *Efficiency.* A parallel language should perform well, not just on theoretical future machines but on the parallel computers that are bought and sold today.

- *Ease of use.* Like so many other construction tasks, parallel programming is straightforward if you have good tools and tedious or impossible if you don't.

Ease of use requires, first, that we support parallel applications with a programming language and not merely an operating system. An operating system might let you invoke directly, in raw form, the services you need in using parallelism—task creation and intertask communication. But an operating system doesn't supply a compiler or interpreter to recognize and process these service requests.

The compiler or interpreter that a parallel *language* provides is essential for convenient programming, because it supports clear syntax, generates compile-time warnings and error messages, collects information that can be used for debugging and tracing, and in some

cases (Linda is an example) performs compile-time optimizations that dramatically improve the system's performance. This kind of compile-time optimization is one reason parallel languages can support far more sophisticated, higher-level programming abstractions than distributed operating systems can.

Ease of use requires, too, that a parallel language depart as little as possible from some convenient, conventional base language. Parallel programming does *not* necessitate doing *everything* differ-

Tuples
don't have addresses;
to find one, you match
field values.

ently. The move from sequential to parallel should not require mastering an entirely new language, or completely rewriting old sequential programs when it comes time to parallelize them.

Finally, and most important, parallelism can be tricky to handle if your programming language forces you to think in simultaneities. An easy-to-use parallel language allows you to develop each thread of a multistranded parallel program independently of the rest to the greatest degree possible. This principle of *uncoupled* parallel-program development is the most important requirement in developing an easy-to-use programming system.

A Bag of Tuples

Writing parallel programs requires the ability to create and coordinate multiple execution threads. Linda is a model of process creation and coordination that is *orthogonal* to the base language in which it's embedded. The Linda model doesn't care how the multiple execution threads in a Linda program compute what they compute; it deals only with how these threads are created and how they can be organized into a coherent program.

Linda consists of a few simple operations that embody the "tuple space" (TS) model of parallel programming. A base language with the addition of these TS operations equals a parallel-programming dialect. We've implemented C-based and FORTRAN-based Linda sys-

tems; work is proceeding on a Lisp-based system, and other groups have implemented other flavors: For example, PostScript Linda (at Cogent Research in Beaverton, Oregon) and Modula-2 Linda (see reference 1).

TS is Linda's mechanism for creating and coordinating multiple execution threads. TS is a bag of tuples, where a tuple is simply a sequence of typed fields; for example, ("new stuff", 0, 16.01) is a three-tuple that consists of a string, an integer, and a real number. Linda provides operators for dropping tuples into the bag, hauling tuples out, and reading them without removing them. To find a particular tuple, we use *associative lookup*: Tuples don't have addresses, so to locate the one we want, we search on any combination of field values. These simple mechanisms take care of all communication and coordination needs. Basically, if task *R* has some data for task *S*, *R* puts the data in a tuple and drops the tuple into TS. *S* can either read the tuple or haul it out, depending on circumstances.

Linda also supports "live tuples," whose fields aren't evaluated until *after* the tuple enters TS. When a live tuple is dropped into TS, it is evaluated independently of, and in parallel with, the task that dropped it in. When its evaluation is complete, it turns into an ordinary data tuple that can be read or removed like any other. This takes care of *task creation*. To create 100 parallel processes or tasks, you simply drop 100 live tuples into TS.

I first described Linda in 1982; Nicholas Carriero built the first implementation for Bell Lab's S/Net in 1984. (This was a major milestone, because it had been widely alleged that Linda was too high-level to be implemented effectively, particularly on distributed-memory machines like the S/Net.) Of the many implementations that followed, the most significant is Jerrold Leichter's system for autonomous VAX/VMS machines on a network.

Tuple Commands

There are four basic TS operations, out, in, rd, and eval, and two variant forms, inp and rdp. First, out(*t*) causes the tuple *t* to be added to TS (see figure 1); the executing process continues immediately.

Second, in(*s*) causes some tuple *t* that matches the template *s* to be withdrawn from TS; the values of the actuals in *t* are assigned to the formals in *s*, and the executing process continues. If no matching *t* is available when in(*s*) executes, the

continued

GRADUATE FROM HARVARD!

DARE TO COMPARE?

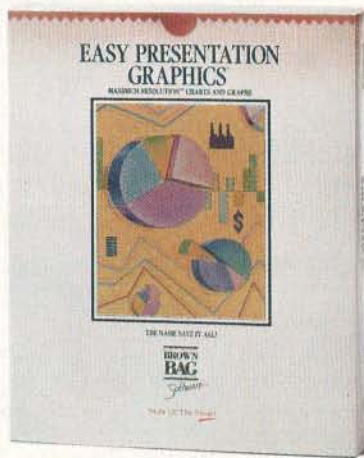
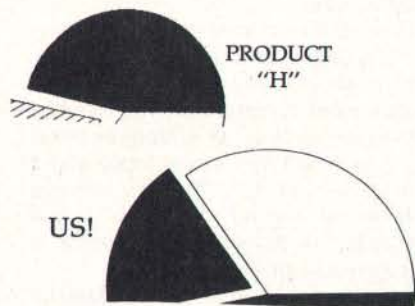

Easy Presentation Graphics produces these graphs in minutes!



EASY PRESENTATION GRAPHICS produces the highest quality output on your printer or your money back!

No fine print. We feel that Easy Presenting Graphics produces the highest quality outputs from your spreadsheets, databases or manually input data. We also feel that it's the easiest to use Business Presentation Graphics on the market. If you don't agree, we'll refund your money. Simple.

Easy Presentation Graphics Product Feature Comparison

Feature	Easy Presentation Graphics™	Harvard™ Graphics 2.1	Freelance® Plus	Graph-in-the-Box™
Basic Graph Types	12	12	10	9
Sideways Printing	Yes	Yes	Yes	No
Free Text	Yes	Yes	Yes	No
Freehand Drawing	No	Yes	Yes	No
Draft Printing	Yes	Yes	Yes	Yes
High Resolution Printing	Yes	Yes	Yes	No
Maximum Resolution, Printing	Yes	No	No	No
3-D Bar Effect	Yes	Yes	No	No
Charts per Output Page	4	4	10	3
Pictograph Charts	Yes	No	No	No
Doughnut Charts	Yes	No	No	No
Text Charts	Yes	Yes	Yes	No
Import ASCII Data	Yes	Yes	Yes	Yes
Import Lotus® 1-2-3 Data	Yes	Yes	Yes	No
Import DIF Data	Yes	No	No	Yes
Import SYLK Data	Yes	No	No	No
Colors Available	8	16	13	16
Print Devices Supported	226	101	24	135
List Price	295.00	495.00	495.00	139.95
Available in ShareWare	Yes	No	No	No

Freelance®, Lotus® and 1-2-3® are trademarks of Lotus Development; Harvard™ is a trademark of Software Publishing; Graph-in-the-Box™ is a trademark of New England Software, Inc.

Easy Presentation Graphics Is Just \$295.00

(\$7.50 shipping & handling
CA residents add sales tax)

TO ORDER CALL
800 523-0764

In California, call (408) 559-4545.

OR MAIL CHECK TO

Brown Bag Software
File #41719, Box 60000
San Francisco, CA 94160-1719



Works on your printer or your money back!
Easy Presentation graphics work on 226 different printers and plotters. That's more than twice Harvard's number! You'll get near Laser Quality on your 9 pin printer or your money back!

BROWN BAG
Software

State Of The Smart

PowerStation

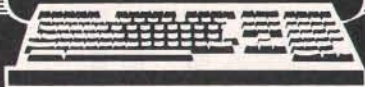

If you have PCs and VAXes, you NEED these products!

For connecting your PC to a VAX, the PowerStation provides the ultimate solution: a VT200 layout keyboard bundled with sophisticated ZSTEM terminal emulation software.

ZSTEM software includes DEC VT240, VT220, VT100, IBM 3101, TEK 4014 and DG D400 terminal emulation.

"Its performance is as perfect as an emulator can get..."

DIGITAL NEWS

For true terminal emulation call (800) 663-8702.

KEA Systems Ltd.

#412 - 2150 West Broadway
Vancouver, B.C. CANADA, V6K 4L9
Tel: 604-732-7411 Telex: 04-352848 VCR
FAX: 604-732-0715



See us at
COMDEX
H7055

UTAH

COBOL™

NEW
VERSION 5.0

\$69.95



For IBM® PC's, XT's, AT's and other DOS machines. Needs only 1 disk drive and 128K memory. This is the one you've heard so much about - with fast compile times, small object code modules, not copy protected, no royalties, and clear error messages. Version 5.0 is based upon ANSI-74 standards with new dynamite features including:

- Nested IF's and nested conditions.
- Indexed files (ISAM) with up to 24 keys (includes START verb). This advanced feature requires the software package Btrieve® which is optionally available.
- ACCEPT (line, column) numerics with decimal point alignment, numeric

checking, AUTO-SKIP, SECURITY, LENGTH-CHECK, EMPTY-CHECK, ATTRIBUTE (color), FROM ESCAPE KEY, DAY, DATE, TIME, DAY-OF-WEEK.

- Fast memory mapped DISPLAY's (line, column) ERASE, BEEP, ATTRIBUTE (color). Can display entire screen with one DISPLAY statement.
- Windowing, pop-ups, color and overlays. This advanced feature requires the software package Saywhat?!™ which is optionally available.
- An easy to use, COBOL source code EDITOR with auto line numbering, A-margin, B-margin tabing with full screen cursor control.

Also available: Utah SuperSort®, a fast sort program callable from Utah COBOL; Utah FORTRAN; Utah BASIC; Utah PASCAL; Utah PILOT. Used by 50,000 professionals, students and teachers in 40 countries. 30-day money back guarantee. Discover the ease and simplicity of COBOL, today!

Phone order rushed
by UPS 2nd Day Air:
(702) 827-3030



Since 1977

Ellis Computing, Inc.
5655 Riggins Court, Suite 10
Reno, Nevada 89502

IBM is a registered trademark of International Business Machines, Inc. Btrieve is a registered trademark of Novell, Inc. Saywhat?! is a trademark of The Research Group. SuperSort is a registered trademark of Micropro International Corporation. Utah COBOL is a trademark of Ellis Computing, Inc. © 1987 Ellis Computing, Inc.

executing process suspends until one is available, then proceeds as before. If many matching *ts* are available, one is chosen arbitrarily.

Third, $rd(s)$ is the same as $in(s)$, with actuals assigned to formals as before, except that the matched tuple remains in TS. Predicate versions of in and rd , inp and rdp , attempt to locate a matching tuple and return a 0 if they fail; otherwise, they return a 1 and perform actual-to-formal assignment.

And fourth, $eval(t)$ is the same as $out(t)$, except that t is evaluated after rather than before it enters TS; $eval$ implicitly forks a new process to perform the evaluation.

TS is an associative memory. Tuples have no addresses; they are selected by in or rd on the basis of any combination of their field values. Thus the five-element tuple (A, B, C, D, E) may be referenced as "the five-element tuple whose first element is A," "the five-element tuple whose second element is B and fifth is E," or any other combination of appropriate element values.

To read a tuple using the first description, we would write $rd(A, ?w, ?x, ?y, ?z)$. This makes A an actual parameter—it must be matched against—and w through z formals, whose values will be filled in from the matched tuple. To read using the second description, we write $rd(?v, B, ?x, ?y, E)$, and so on. Associative matching is actually more general than this: Formal parameters (or "wild cards") may appear in tuples as well as match templates, and matching is sensitive to both the types and the values of tuple fields.

The Parallel Solution

The following problem may sound esoteric, but it's a good example, not only because the parallel solution is very simple and effective, but because the problem isn't really esoteric at all. It's a portent of parallelism's future role at the workstation level.

When new DNA sequences are discovered, geneticists often need to determine which previously known sequences they resemble. *Resemblance* is a qualitative measure that can be approximated using string-matching-like algorithms. Known sequences are kept on file in a database called GenBank; GenBank is large, and with progress in the widely touted "sequencing the human genome" project, it will grow much larger.

Skipping over some subtleties, one simple but effective approach to a parallel GenBank searcher is to create a col-

continued

THE NEW STANDARD FOR HIGH PERFORMANCE STATISTICAL SOFTWARE

CSS

**COMPLETE STATISTICAL SYSTEM
WITH DATA BASE MANAGEMENT
AND GRAPHICS**

A powerful, comprehensive, elegant, and super-fast statistical package for IBM (PC, AT, PS/2) and compatible computers. ■ The CSS optimized user interface with fast hierarchical menus incorporates elements of artificial intelligence; even complex analyses require only a few keystrokes (batch processing is also supported). ■ CSS features comprehensive, state of the art implementations of: *Basic statistics, Multi-way frequency tables, Nonparametric statistics, Exploratory data analysis with analytic graphs, Multiple regression methods, Time series analysis with modeling and forecasting (incl. full ARIMA), General ANOVA/ANCOVA/MANOVA, Contrast analysis, Discriminant function analysis, Factor analysis, Principal components, Multidimensional scaling, Item analysis/Reliability, Log-linear analysis, Cluster analysis, Non-linear estimation, Logit/Probit analysis, Canonical analysis, Survival and Failure Time analysis (Censored data), Quality Control analysis, and much more.* ■ All statistical procedures are integrated with fast data base management and instant, presentation quality graphics (over 100 types); full support for all mono and color graphics boards (incl. VGA) and over 100 plotters and printers (incl. the HP and Postscript standards). ■ All CSS screen output is displayed via customized Scrollsheets™ (i.e., dynamic, user controlled, multi-layered tables with cells expandable into pop-up windows); all numbers in a Scrollsheet™ can be instantly converted into a variety of presentation quality graphs; contents of different Scrollsheets™ can be instantly aggregated, combined, compared, plotted, printed, or saved. ■ The flexibility of the CSS input/output is practically unlimited: CSS offers an intelligent interface (read/write) to all common file formats (Lotus, Symphony, dBI, dBIII+, DIF, SYLK, . . .) and special utilities to easily access data from incompatible programs; graphics can be saved in files compatible with desktop publishing programs (Aldus, Ventura). ■ CSS data files can be as large as your operating system (DOS) allows; OS/2 version coming soon. ■ CSS precision exceeds the standards of all common precision benchmarks. ■ *Technical note: The CSS user interface and all I/O were written in Assembler and bypass DOS; graphics and data management were written in Assembler and C; the computational algorithms were written in Assembler and optimized Fortran.* ■ \$495 (plus \$5 sh/h); 14-day money back guarantee.

Circle 316 on Reader Service Card



StatSoft

2325 East 13th Street ■ Tulsa, OK 74104 ■ (918) 583-4149

Fax: (918) 583-4376

Overseas Offices: StatSoft of Europe (Hamburg, FRG), ph: 040/4200347

StatSoft UK (London, UK), ph: 0438/310056 or 316561. Hearne Software (Melbourne, Australia), ph: 613-497-4276

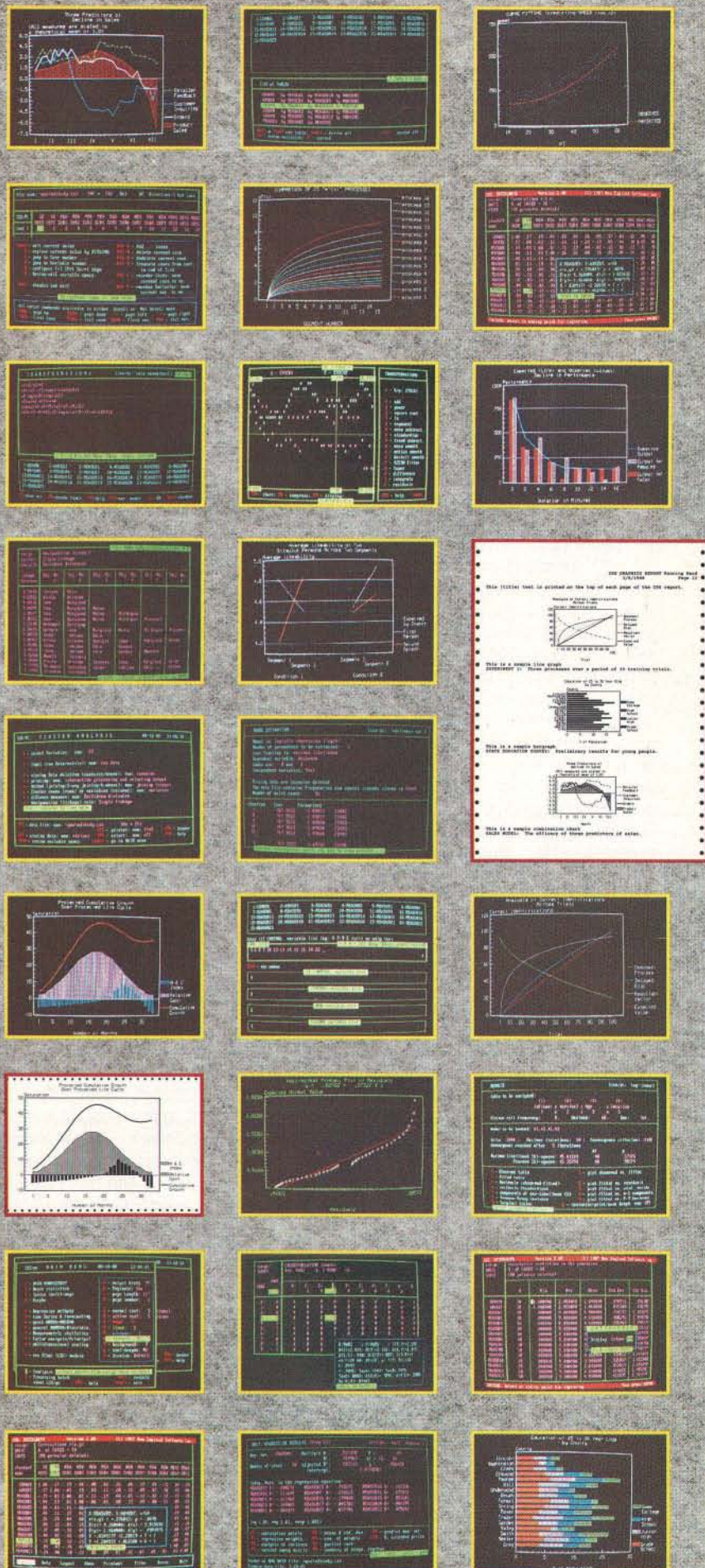

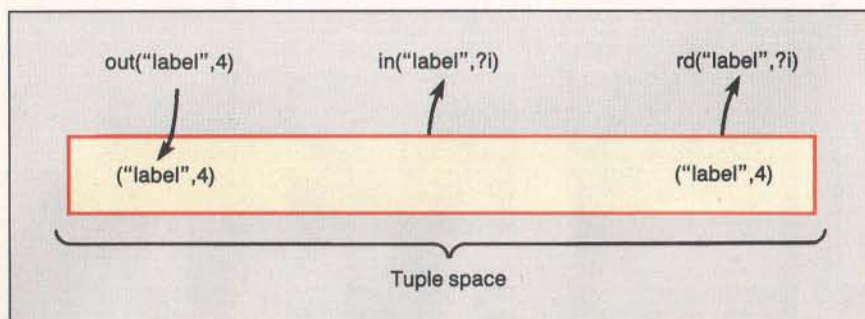

Figure 1: The instruction `out("label", 4)` adds this tuple to tuple space while `in("label", ?i)` withdraws a matching tuple from tuple space; `rd("label", ?i)` simply reads a matching tuple without removing it.

lection of identical search workers and one master task (on a 64-node hypercube, that's 63 searchers and one master). The master hands each searcher a copy of the target sequence; then it passes out sequences from the database. Searchers grab a sequence, compare it to the target, return the result to the master, and then grab another sequence.

It's easy to see how a Linda program might accomplish this. The master puts the target in a tuple, and each worker reads it. The master then scans the database, putting each sequence in a tuple; workers repeatedly reach into TS, grab a sequence tuple, compare it to the target, and put the result in another tuple.

A few important details: The sequences vary greatly in length; load balancing is better if searchers look at the long sequences first and work their way down to the short ones. (This prevents a run ending with the last active worker holding everything up while it performs a comparison against a very long sequence.) It's easy to implement this task ordering using Linda; you simply arrange the sequence tuples in a stream by using one field of each tuple as a stream index (the technique is described in reference 2). Searchers disassemble the stream from the front end, while the master adds sequences to the tail. Any database is potentially larger than available RAM, and so the master gradually plays out the database into TS, using a watermark algorithm (again, easy to implement in Linda) to avoid flooding it. (This program was designed and written by Nicholas Carriero of the Yale Research Faculty.)

How Well Does it Work?

The central issues in parallel programming are communication and coordination: moving data and results among the various worker tasks and ensuring that all workers have what they need when

they need it. Linda makes communication and coordination easy because of the simple physical model on which it's based—merely a bag of objects, with new objects tossed in and old ones consulted or removed as needed. Linda is an *uncoupled* programming model—no worker task deals directly with any other; all transactions go through TS.

For example, when a worker has produced some intermediate result, it needn't know or care which other workers will need it. Labeled with any descriptive tag that seems appropriate, the new result is simply tossed into TS, and anyone who wants it can come and get it. Of course, Linda programming isn't merely a matter of tossing isolated tuples into the bag; TS is a form of distributed, associative, object *memory*, and programmers can build any kind of data structure they need out of tuples.

Linda has been implemented on shared-memory parallel computers like the Encore Multimax, Sequent Balance and Symmetry, and Alliant FX/8; on distributed-memory computers like the Intel iPSC-2 hypercube; on a VAX/VMS local-area network; and on several custom architectures, among them AT&T Bell Labs' S/Net and the Tadpole at the Vrije Universiteit in Amsterdam. Krishnaswamy of Yale and Ahuja of Bell Labs are building the Linda Machine, which supports Linda operations in hardware; the first boards have just become operational. Other groups have ports under way or planned to systems like transputer processors running the Trollius operating system, the BBN Butterfly running the Mach operating system, and the NCUBE hypercube machine.

Portability is good, but real availability is even better. Scientific Computing Associates of New Haven, Connecticut, is the current leader in the infant field of commercial Linda systems. It has systems available for the Encore and Se-

quent parallel machines. Our group at Yale distributes a simulator for Sun workstations. The VAX/VMS network system and the Intel system are each available through Yale to research sites; neither is "commercial" yet.

Several companies are working on their own Linda systems. Among them are Cogent Research of Beaverton, Oregon, producers of transputer-based parallel workstations; Topologix of Denver, Colorado, producing transputer-based add-on boards for Sun workstations; Human Devices of New York, producing computation servers for Macintosh networks; and AOX of Waltham, Massachusetts, which produces add-on boards for IBM PS/2s.

A quick summary of the run-time data for the DNA database program on two different machines, an 18-processor Encore Multimax and a 64-processor Intel iPSC-2 hypercube, shows that performance is excellent. A database search that would have taken about 5 hours on a single iPSC-2 processor (each processor is an Intel 80386) takes about 5 minutes running in Linda on the 64-node cube. While the Encore and Intel machines differ radically, the same Linda program runs, and performs well, on both.

The DNA parallel database program doesn't stress the efficiency of the Linda system much. There are Linda programs that are considerably more fine-grained than this one—they do less computing and more intertask communicating—that also perform well. Some are discussed in reference 3.

Finally, running Linda on 14 VAXes, some in California and some in New Mexico, Robert Whiteside of Sandia National Labs has handily beaten a Cray (both a Cray 1S and one processor of a Cray X-MP) on production code for parameter-sensitivity analysis (see reference 4). How he did it is the software equivalent of powering a city on recycled garbage: Whiteside built his "virtual supercomputer" out of nighttime VAX cycles that no one else wanted.

Coming Attractions

The DNA example is significant in pondering the future of the parallel workstation. There are lots of databases in the world. Most current-generation machines search them slowly, particularly if the search involves complex or dynamic search criteria. A parallel workstation that can search a large database quickly holds potential for a qualitative change. It lets the average information consumer tap into large knowledge reserves rou-

continued

Tandy® Computers: The broadest line of PCs in America.



The Tandy 1400 LT

The affordable MS-DOS® based portable computer.

Here's a portable computer that's a true IBM® PC compatible. With a removable rechargeable battery pack built in, the Tandy 1400 LT is perfect for people on the go—like busy executives, sales personnel and journalists. Or use it like a desktop computer.

The Tandy 1400 LT features a high-resolution *backlit* liquid crystal display. The 80-character by 25-line resolution gives you the same quality of display as a full-sized monitor. And it's remarkably clear, thanks to the latest in "supertwist" LCD technology.

The 8088-equivalent microprocessor has a 7.16 MHz clock speed (vs. 4.77 MHz for most other PC-compatible portables). Standard equipment includes two 720K 3 1/2" built-in disk drives and 768K RAM—ample memory to run today's powerful MS-DOS based programs.

The Tandy 1400 LT also includes a parallel printer adapter, RGBI and composite monitor outputs, a real-time clock and an RS-232C serial interface. You even get MS-DOS 3.2 and GW-BASIC.

Come to your local Radio Shack and see the Tandy 1400 LT.

Send me a 1989 RSC-20 computer catalog

Mail to: Radio Shack, Dept. 89-A-665
300 One Tandy Center, Fort Worth, TX 76102

Name _____

Company _____

Address _____

City _____ State _____

ZIP _____ Phone _____

Tandy Computers: Because there is no better value.™

MS-DOS/Reg. TM Microsoft Corp. IBM/Reg. TM IBM Corp.

Radio Shack®
The Technology Store™

A DIVISION OF TANDY CORPORATION

Circle 399 on Reader Service Card

DEFINICON & PARASOFT Parallel Programming Solutions . . .

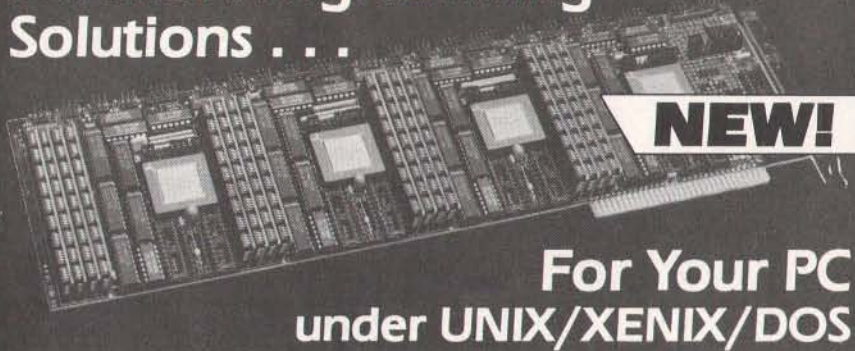

NEW!

For Your PC under UNIX/XENIX/DOS

■ **SOFTWARE** Parasoft and Definicon Systems introduce EXPRESS, the most advanced parallel programming environment for the transputer. It includes a C compiler, a parallel source-level debugger, a parallel performance monitor and facilities for graphics, I/O, message passing, semi-automatic decomposition and load balancing.

■ **SPEED** Get up to 40 MIPS per board with 4 INMOS 32-bit T800 transputers. Tap the performance potential of multiple transputers with EXPRESS.

■ **PRICE** Low cost entry into parallel processing. Now you can transform your existing PC into a parallel-processing development workstation with Definicon transputer boards and Parasoft software.

ParaSoft

27415 Trabuco Circle, Mission Viejo, CA 92692
(714) 380-9739 FAX (714) 458-7557

Definicon Systems, Inc.

1100 Business Center Circle, Newbury Park, CA 91320
(805) 499-0652 FAX (805) 498-3559

© UNIX, XENIX, DOS, INMOS are trademarks of their respective companies.

tinely, and in a sophisticated way.

Most of our current research focuses on new and better Linda systems and on scientific applications in Linda. But parallel workstations, and networks of conventional workstations, have enormous potential as well. Linda is a good tool for graphics applications: Ken Musgrave of Benoit Mandelbrot's group at Yale uses a Linda program to produce ray-traced images of fractal landscapes. Linda is also a good tool for building simulators: A circuit-level very-large-scale-integration simulator and a Monte Carlo radiation-damage simulation at Sandia are two examples.

Linda seems to be a good development tool for fast database-access and expert-database systems; for expert monitors that scan and analyze collections of incoming data streams (current work involves an ICU monitor system, but there may be applications ranging from automobile traffic control to financial monitoring); for "daemon databases"—databases with embedded expert daemons that examine and comment on the evolution of the objects modeled; and for distributed information services that can run on dynamic collections of autonomous microcomputers.

Some of these applications are well-developed research efforts, and some are only in the planning stage. But these systems and others like them will eventually contribute to a new era of parallel software—the age of software microcosms, knowledge filters, and information reservoirs—that is just around the corner. ■

REFERENCES

1. Borrmann, L., and M. Herdieckerhoff. "Linda Integriert in Modula-2: Ein Sprachkonzept für Portable Parallele Software." *Proc. 10. GI/ITG-Fachtagung Architektur und Betrieb von Rechenystemen*. Paderborn, March 1988.
2. Carriero, N., and D. Gelernter. "How to Write Parallel Programs: A Guide to the Perplexed." Yale University Department of Computer Science RR-628, May 1988.
3. Carriero, N., and D. Gelernter. "Applications Experience with Linda." *Proceedings ACM/SIGPLAN Symposium on Parallel Programming*, July 1988, pp. 173-187.
4. Whiteside, R. A., and J. S. Leichter. "Using Linda for Supercomputing on a Local Area Network." *Proceedings Supercomputing '88*. To appear.

David Gelernter of the Yale University department of computer science in New Haven, Connecticut, is one of Linda's developers. He can be reached on BIX c/o "editors."

The World's Lowest Price A to D Size Flatbed Plotter.

(8½" x 11" to 22" x 34" plot sizes)

A breakthrough in X-Y positioning gives remarkable performance and low price in the MURAL™ Plotter.

■ Plots any size from A to D +

Maximum pen travel is 25" x 34". Pre-printed media is easily registered to this plotter.

■ Simplified flatbed construction for durability and performance

Contains a precision molded zero backlash drive chain embodying two steel aircraft cables. Uses no moving electrical components in the pen carriage. Assures virtually perfect repeatability every time.

■ HPGL compatible

Works with all software that drive H-P plotters including AutoCAD, VersaCAD, and DesignCAD. Runs on all systems from IBM PC (and compatibles) to Apple and more.

■ Prints on any media

Plots on any size media to ¼" thick, including bond, vellum, mylar, posterboard.

■ Fits anywhere

Designed for desktop or space-saving wall mount use.

■ Satisfaction guaranteed or your money back

If not completely satisfied, return it within 30 days of purchase for a full refund.

■ FREE information kit

Phone or write today for sample plot, brochure, and name of nearest dealer.

800-323-3283 Extension 118
(In MA 413-534-4400)

Mural is a trademark of United Innovations

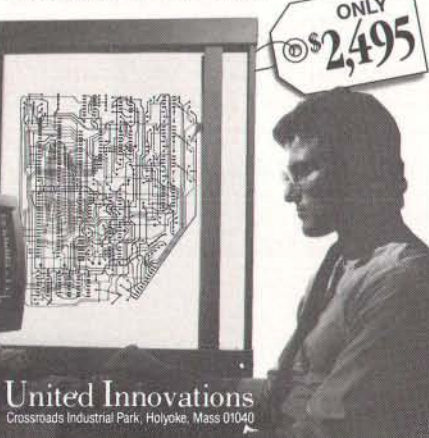

UI

United Innovations

Crossroads Industrial Park, Holyoke, Mass 01040

Affordable Large Format Plotting Starting at \$1695.*

A-E
\$2695.
(sugg. ret. \$2995.)

A-D
\$2295.
(sugg. ret. \$2695.)



*\$1695—Model 3610 C/D
(not shown)
Same style as 3600 A-D
Handles C & D size media

Features that say value...

Economical: \$1,000 less than other large format plotters.

Compatible: Operates with all popular CAD software supporting DM/PL.™

Multiple Media Sizes as small as 8½" x 11" or as large as 36" x 48" eliminates the need for a second plotter.

Practical speed you can really use: 10" per second assures good drawing throughput while optimizing the speed at which most plotter pens can draw without skipping.

Repeatability and Resolution: .004 assures quality suitable for the most demanding applications including PCB artwork.

Vacuum Paper Hold Down guarantees perfect registration.

Unique: X&Y rescaling allows calibration to one part in 10,000. Ideal for applications where scale is critical.

CALL NOW AND WE'LL SEND YOU
A FREE SAMPLE PLOT.

(415) 490-8380 Fax (415) 490-3906

Dealer inquiries invited.

ZERICON

40491 Encyclopedia Circle
Fremont, California 94538

Made in USA

DM/PL is a trademark of Houston Instrument

TimeWand™ - Gathering Information

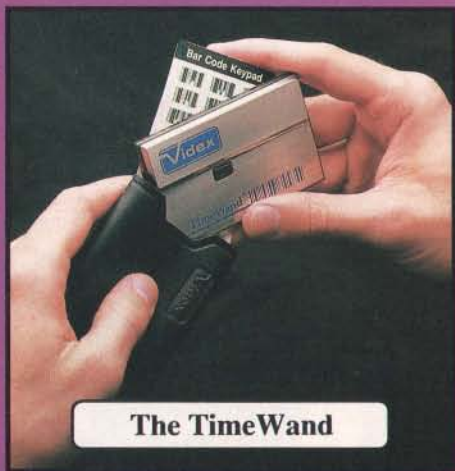

The TimeWand

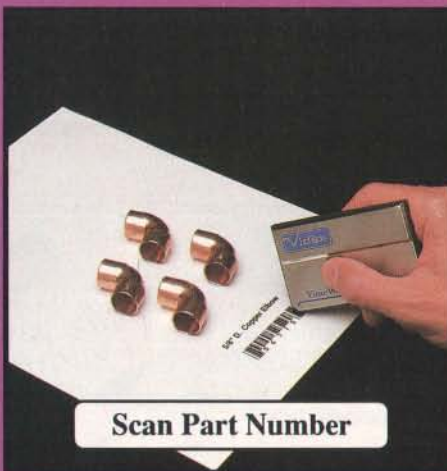

Scan Part Number

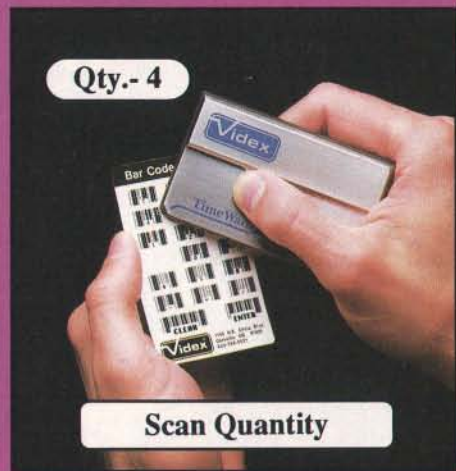

Qty.- 4

Scan Quantity

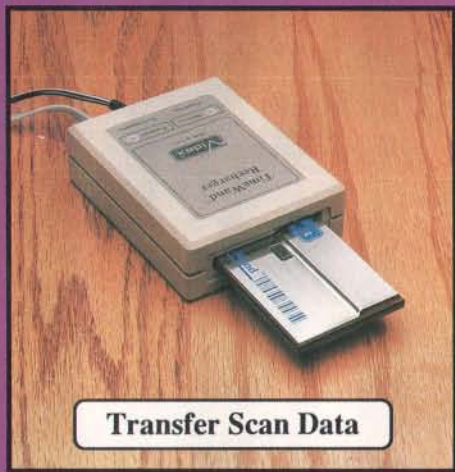

Transfer Scan Data

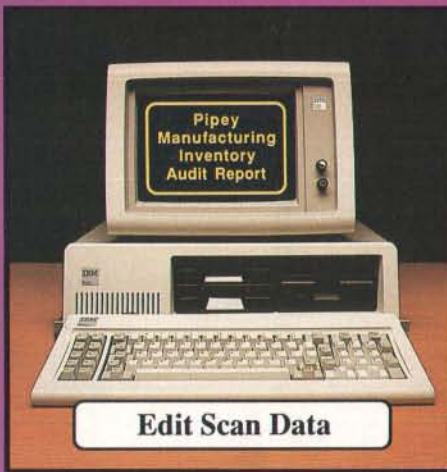

Edit Scan Data

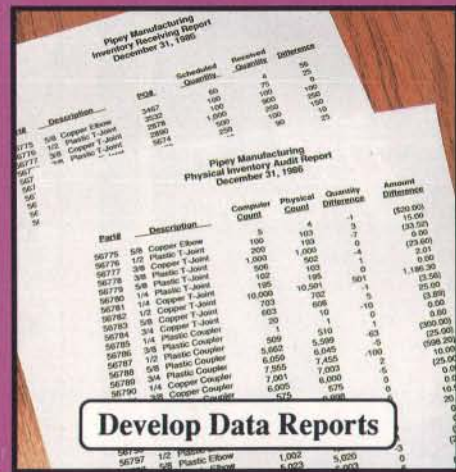

Develop Data Reports

Bar Codes, Computing, and the TimeWand... a Closer Look.

"A successful business runs on accurate, timely information." An obvious statement perhaps, but one that every personal computer user must keep in mind. In order to get the reports we require, we must ensure that the information on which we base our decisions is as up-to-date as possible. This is where a bar code reading system such as the TimeWand can be used to improve efficiency in the office or workshop. The TimeWand provides a convenient way to ensure that your computer has all the facts, all the time.

Let's use inventory control as an example. Once an inventory system is set up on the computer, you are faced with the important task of keeping the inventory up to date. The TimeWand gives you a quick and efficient method of getting information into your computer system. To enter an item into inventory (such as the copper elbows shown above), all you need to do is scan the item, the quantity, and transfer the data to your computer. By using TimeWand, you bypass the time-consuming steps of writing down every transaction, deciphering hand-written notes, typing in each inventory transaction by hand, and searching for transcription errors that might have occurred. The TimeWand is an ideal tool for gathering information for use in your business.

From time-billing to tracking work orders to monitoring security, the TimeWand provides an inexpensive solution for your data collection needs. Call or write Videx today for more information about how the TimeWand can help in your business.

TimeWand (2K version) - \$198
 Recharger - \$149
 TimeWand Communication Software (IBM) - \$299

Software available for the Macintosh, Apple // family, and Tandy (Model 100 and 200).



1105 N.E. Circle Blvd., Corvallis, OR 97330-4285
 503-758-0521

See us at ScanTech in Chicago Nov. 1-3, Booth 982
 and COMDEX in Las Vegas Nov. 14-18, Booth 2998
 Videx is a registered trademark and TimeWand is a trademark of Videx, Inc.

The Third Dimension

The 3-D Computer demonstrates the feasibility of the wafer approach

Michael J. Little and Jan Grinberg

Real-time image processing, and two-dimensional data processing in general, require enormously high data-throughput capabilities. Image and signal processing systems currently on the drawing boards have requirements for processors capable of between 10^{11} and 10^{12} operations per second. Parallel processing appears to be the only route available to achieve these extraordinary processing rates.

While there are several robust taxonomies for the various parallel-processing approaches, we have divided the field into two segments: multiple instruction-multiple data (MIMD) types, and single instruction-multiple data (SIMD) types.

The MIMD approach breaks a (large) processing task into subtasks and assigns each subtask to a separate processor. Each processor executes the necessary series of operations on its data values. The major difficulty with this approach comes from a frequent need for one processor to communicate with another processor so it can complete its task. This requires precise scheduling of the exchanges between otherwise independently running pro-

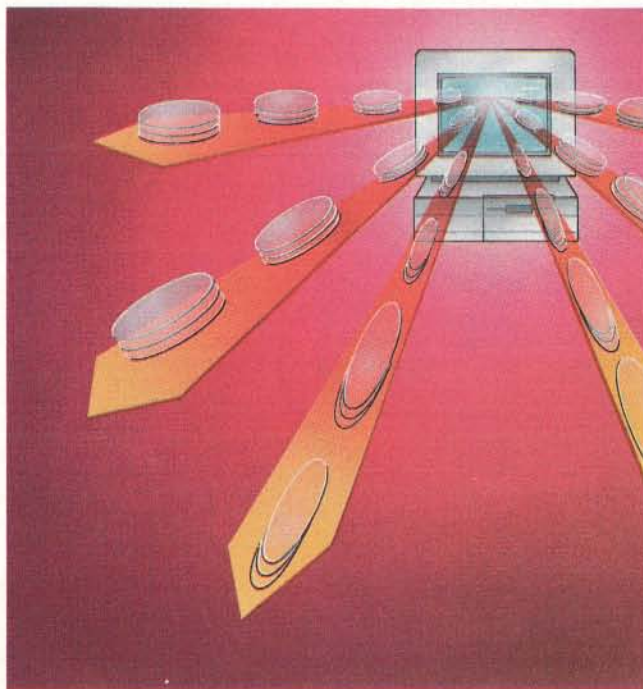

grams. As the number of processors gets larger, the interdependencies among programs become more complex. Load balancing—keeping each of the processors fully occupied—is another difficulty.

The SIMD approach assigns data values to each of the processors and then executes the same series of operations on each of the data values in *lockstep*. Thus, there is a single instruction stream, simi-

lar to that used in a uniprocessor except that the operations are being performed on all the data values simultaneously. For this reason, we have decided on an SIMD type of architecture.

A number of SIMD array processors have been successfully demonstrated in conventional two-dimensional IC technology. These include the ILLIAC IV, the Distributed Array Processor (DAP), the Cellular Logic Image Processor (CLIP-4), and the Massively Parallel Processor (MPP) (see references 1 to 4). In conventional technology, an array processor is built from an array of IC chips, each containing one or more processors, which are then linked together.

If we consider each chip in the array as a set of subfunctional units—A, B, C, and so

on—then an alternative approach exists with three-dimensional integration. With this technology, the complexity of each processor in the array is determined by the depth of the 3-D stack, not just by the lateral dimensions of the circuitry. At Hughes Research Labs, we have built a 3-D Computer that demonstrates the feasibility of this approach.

continued

A number of extremely important system benefits result from 3-D partitioning: small size, low power consumption, high yield of WSI circuits, high reliability, and low cost. The massively parallel architecture ensures high throughput.

A Different Architecture

The basic structure of the 3-D Computer is an array of $N \times N$ identical elements contained on a stack of silicon wafers (see figure 1). The layout consists of an array of processors arranged horizontally, with the elements of each processor in the array connected vertically. If you look down the stack, you see an array of primitive computers, the individual elements of which are assembled underneath each other. Signals pass vertically through the stack along bus lines composed of *feedthroughs* (signal paths through the wafers) and micro-bridge *interconnects* (signal paths

between the wafers).

Each wafer in the stack contains a complete $N \times N$ array of one particular type of processing element, such as an array of Shifters or Accumulators. All processors in a 3-D Computer are therefore identical, composed of the same vertical combination of computing elements.

A more schematic view of the 3-D structure depicts the stack edge-on and shows the control processor used to exercise the array hardware as a separate unit (see figure 2). The architecture is *word parallel* and *bit serial*; in other words, while the individual processors in the array employ serial arithmetic, they all operate simultaneously, in word-parallel fashion. Thus, the circuitry of the individual computing elements can be extremely simple, achieving the high densities necessary for its anticipated applications. The massive parallelism at

the processor level more than compensates for the loss of speed incurred by using serial arithmetic.

In this architecture, data flows in a parallel fashion from the elements of one wafer to the corresponding elements of another; bit-serial processing occurs during the transfer. The functional elements are linked together vertically with a bus; thus, data can pass between *any* two wafers in the stack, not just between adjacent wafers.

For data-dependent processing, the transfer of arrays of data from one wafer to another can be mediated by one or more additional wafers. Statistics gathered from extensive simulations of a wide variety of algorithms indicate that each data transfer involves an average of 2.5 wafers. Pipeline registers in each wafer's control path let you configure wafers for the next operation while the stack is executing the current operation.

The normal word length (the length of the shift registers in each cell) is 16 bits. Consequently, the overhead associated with sequentially configuring the individual wafers is roughly 6 percent, which corresponds to using 1 clock cycle out of 16 to transfer the contents of the pipeline registers to the control drivers. Thus, an average of 1 out of 17 cycles is lost to control operations.

Five elemental wafer types are sufficient to perform all the algorithms we have studied to date (arithmetic operations, logical operations, matrix operations, image-analysis algorithms, and radar processing). Of the five—Accumulator, Shifter, Replicator, Counter, and Comparator—only the first two are essential; the other three enhance performance on certain common operations.

This modularity of functionality at the wafer level lets us assemble 3-D Computers optimized for particular applications. For example, an efficient radar-signal processor can be created from these five wafer types, as can a high-throughput linear algebraic processor; however, a slightly different combination of the wafer types would be used.

Partitioning the circuits into these five small modules has a dramatic effect on programmability. Each wafer type has an array of fairly simple, identical functional units (roughly 200 gates). Each of these units is controlled by roughly 10 control lines common to each array element. Thus, the ratio of logic to control lines—roughly 20—is 10^2 to 10^3 times higher than is found in current conventional two-dimensional implementations, providing you with control virtually down to the AND and OR gate level.

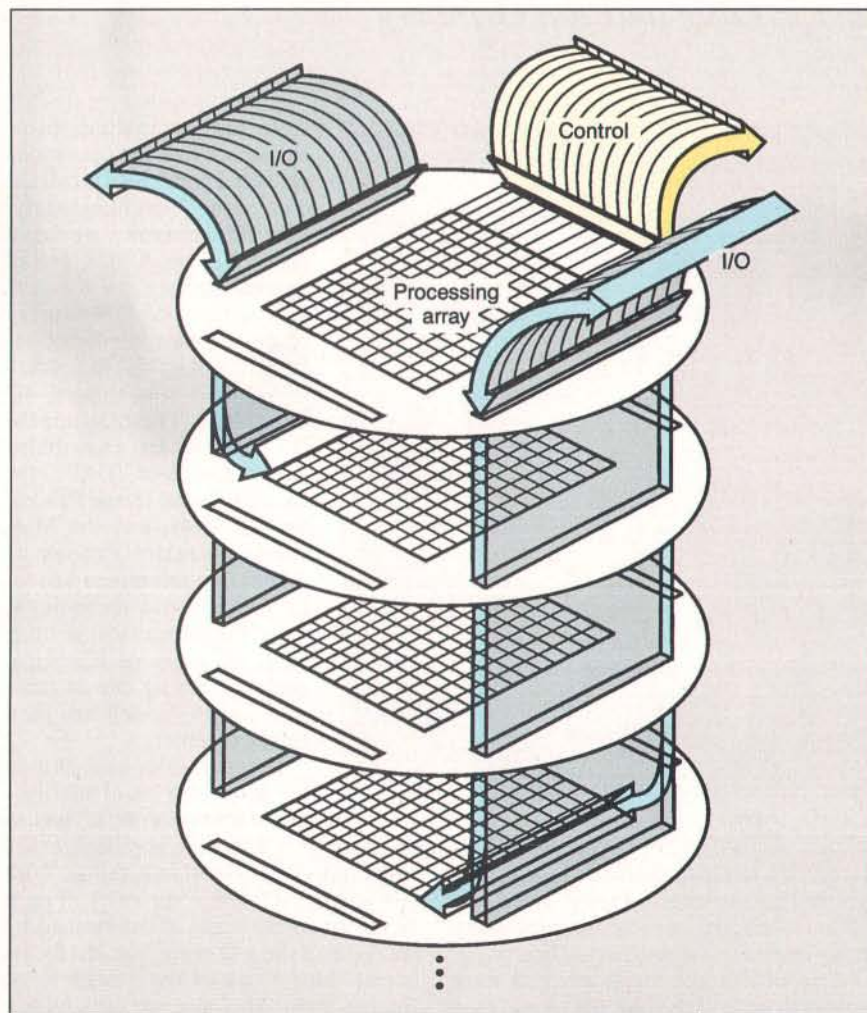

Figure 1: The 128-by-128-element 3-D Computer. Notice the literal stack of array-processing wafers.

Technical Necessities

Three underlying technologies make possible the creation of the 3-D Computer: feedthroughs, interconnects, and wafer stacking. Feedthroughs make communication between the opposing faces of a silicon wafer possible by routing signals through the wafer. Interconnects make electrical communication between adjacent wafers stacked one on top of another practical. And wafer stacking enables the circuits on each of the wafers to precisely register with one another.

With these three revolutionary technologies, it's feasible to assemble a stack of circuit-bearing wafers, each of which can communicate directly with any other circuit above or below it.

Feedthroughs

We evaluated several possibilities for communicating through a silicon wafer, including optical communication in the near-infrared range where silicon is transparent, creating holes through the wafer and filling them with a conductor, and thermomigration. Each approach has its merits and its drawbacks.

The first approach, optical communication through a silicon wafer, is possible with near-infrared radiation. Silicon is transparent to radiation beyond approximately 1.1 micrometers (μm), so you can simply transmit through it in unmetallized areas. This approach has three difficulties: avoiding crosstalk between closely spaced communications channels (diffraction, reflection, and scattering mix the separate communication beams together); the complexity resulting from hybridizing the emitters and detectors onto the silicon wafers (generating optical beams would require light-emitting or laser diodes at each circuit node); and, most difficult, power dissipation and thermal management. In complex systems with large numbers of communication paths, the poor efficiency of LEDs and laser diodes—the ratio of electrical power in to optical power out—puts an enormous burden on the power-distribution and heat-dissipation systems.

The second approach, small-diameter holes through a silicon wafer, can be produced by several techniques, including laser drilling and chemical (anisotropic) etching. The main pitfall with through-the-wafer holes is the drastic reduction in the wafer's mechanical integrity. It appears most practical to produce through-the-wafer holes prior to circuit fabrication; doing it afterward introduces grave risks to the circuits because of the destructive nature of the two processes. If the wafers are perforated with tiny holes,

handling them becomes a nightmare. Stress concentration around each of the holes and the crystalline structure of the wafer encourage crack propagation and shattering if stressed by tweezers as in normal handling.

The third approach is thermomigration. In the early 1950s, Pfann of Bell Telephone Laboratories showed that the phenomenon of temperature-gradient zone melting (thermomigration) could be used to dope semiconductors and to produce p-n junctions in semiconductor materials. For the thermomigration of aluminum in silicon, the surface of an n-type silicon wafer is coated with a layer of aluminum metal patterned into an array of small dots using conventional semiconductor processing. The silicon wafer, with its array of aluminum dots, is mounted in a specially designed furnace capable of producing the requisite vertical thermal gradients at the desired operational temperature, typically 1100°C. When the temperature of the wafer exceeds 660°C, each aluminum dot melts and begins to dissolve the underlying silicon.

When the aluminum dot is saturated with silicon, the thermal gradient established across the wafer becomes the

dominating effect. The dissolving and precipitating of silicon at the interface between the molten silicon and aluminum in the droplet is in dynamic equilibrium. But because the bottom side of the droplet is slightly warmer than the top side, in effect, silicon is dissolved on the warmer (bottom) side and precipitated on the cooler (top) side. Thus, the molten aluminum-silicon droplet "eats" its way through the silicon wafer. The precipitated single-crystal silicon contains a high concentration of aluminum, which is a p-type dopant. When the process is completed, you have highly conductive p-type channels penetrating through the silicon wafer, each one diode-isolated from the others.

The advantages of thermomigration are that the wafers don't require hybridizing with additional materials with distinct thermal and mechanical properties, and that they aren't perforated. At first glance, they are indistinguishable from ordinary wafers without any through-the-wafer communication channels.

Interconnects

The 3-D Computer also requires wafer-to-wafer interconnections. The antic-

continued

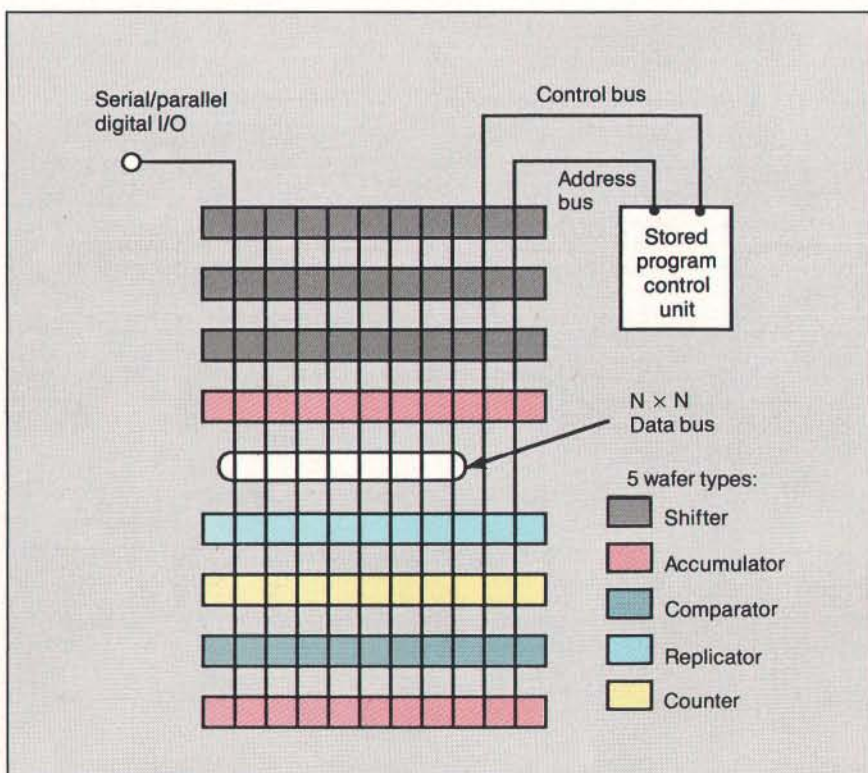

Figure 2: Schematic of the system organization. The silicon wafers are represented by horizontal rectangles, and the vertical lines running through the stack depict the data, control, and I/O buses.

pated need for a large number of contacts (10^4 to 10^6) means you need extremely high reliability and small contact dimensions. Also, any proposed interconnection technique must be compatible with somewhat distorted (nonflat) wafers. Having a bus that passes through all wafers in the stack requires that the contacts be electrically fast, of low capacitance, and of low resistivity. These are very stringent requirements, and they limit the number of feasible approaches.

Spring contacts (see figure 3) are fabricated so the height of the tunnel underneath them is enough to compensate for the distortion across a wafer; thus, you can reliably achieve complete interconnection of all contacts. They are batch-fabricated by vacuum evaporation, a process compatible with silicon technology.

Contacts on adjacent wafers are rotated 90 degrees with respect to each other when mated. Thus, the springs make contact at right angles, forming a cross. An important advantage of the bridge-type spring is that it can be as long as the computing cell and still occupy only a small amount of valuable silicon real estate. This ensures a more secure interconnection and is very tolerant of

wafer-to-wafer lateral displacements. The stack can be disassembled and the individual wafers demounted. In addition, the spring remains flexible when the assembled stack is thermally cycled.

The principal fabrication steps for the spring contact are these: A spacer about 50 μm or thicker is evaporated or deposited on the circuit wafer; the spring contact metal is evaporated on top of the spacer; then the spacer is etched away, leaving a freestanding flexible microbridge (see photo A).

To secure the contact between two microsprints, each has an outer coating of indium-tin solder that is vacuum-deposited at the same time as the structural layer of the microbridge. After the stack is assembled, the stack is heated to the melting point of the solder, and each mated pair of microsprints is fused together, resulting in a permanent, reliable connection.

Getting Bigger Every Day

While the 3-D technologies represent an unprecedented level of 3-D integration, the ability they provide to communicate vertically, between wafers, is still nearly two orders of magnitude lower than stan-

dard two-dimensional communications. Thus, partitioning hardware across the various levels of the wafer stack is a very important consideration.

The overall structure of a cellular array is that of an $N \times N$ array of identical computing elements, working in lockstep, executing a common program. We had to decide how to distribute this array's circuitry across a stack of wafers. Since we chose serial logic for the cell circuitry, only a single primary data line would be associated with each computing element. Thus, it was natural to run this array of single data lines vertically through the stack, spreading the functional units of each computing element vertically across multiple wafers.

The detailed partitioning of the processing elements across the wafers is determined by a variety of factors. For one, the cells on all the wafers need to be approximately the same size. If they are not, the largest cell determines the cell areas on other levels, resulting in a waste of silicon.

Overall constraints on the cell size are imposed by the size of the array, the minimum feature size of the circuit technology, and the overall size of the wafers. In general, the trade-off is to use more layers in the stack rather than larger cells in each layer. Current and projected application requirements call for processing arrays of 128 by 128 elements and 512 by 512 elements, respectively. Since the horizontal dimensions are limited by the size of the wafers available, the cell circuitry on each wafer must be strictly limited.

On the other hand, several factors argue for larger cells. An absolute lower limit is set by the requirement that the circuitry on each level pass some minimum meaningful level of functionality. Beyond that, some overhead is associated with the cells themselves and with getting information off-chip.

One component of this overhead is the area consumed by the 3-D feedthroughs themselves, about 2 by 2 mils each. In addition, between 5 and 10 transistors would be required to implement the necessary interface between the cell circuitry and the data bus. This overhead would be the same regardless of the size of the rest of the cell. Thus, efficient use of silicon indicates the use of larger cells.

Balancing these constraints means having cells of roughly 200 gates each on each of the functional planes of the 3-D Computer. This design enabled us to fabricate four 32 by 32 arrays on a 4-inch wafer; it will let us put a 128 by 128 array

continued

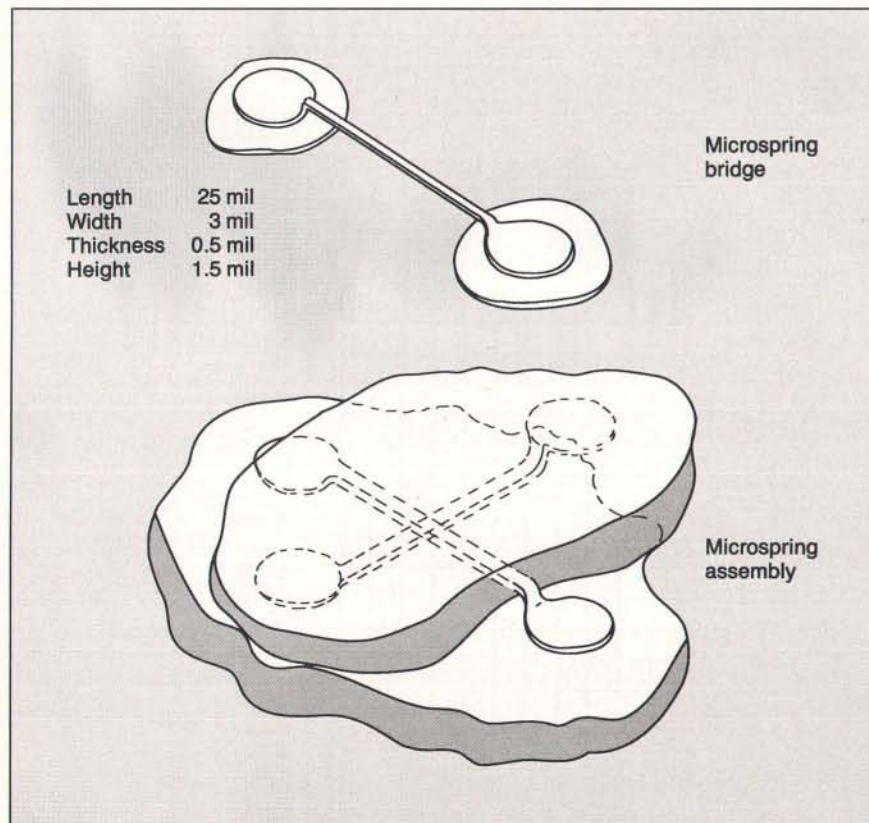

Figure 3: The microspring interconnects. Notice how adjoining microspring bridges are assembled at 90-degree angles from each other.

Cross-Byte™
3.5" Micro Drive Conversion

Add Advanced Storage Capacity to Your PC Without Buying a Totally New System

See Us at
COMDEX Booth # 104



Regardless of the operating system you're running on your PC, you can quickly, easily and economically make your system compatible with today's advanced 3.5-inch micro-floppy drives.

The Sumitronics Cross-Byte is a complete micro drive conversion system that you can install and use...immediately.

Simply remove one of your 5.25-inch drives and slip in the Sumitronics high-capacity micro drive. Type "install," reboot your system and enjoy advanced capacity and advanced convenience.

In minutes, you'll have up to 1.44 MB micro-floppy capacity in your desktop system without discarding the investment you've made in your 5.25-inch programs.

If you use a laptop computer on the road, you can plug the microfloppy diskette into your desktop system at home or at the office and complete your work. You can also add the convenience and expanded storage capacity to a PC, XT[®], AT[®] or compatible.

Nothing could be faster, easier or more economical.

To add advanced read/write compatibility to your desktop system, find out why we supply the world's leading personal computer manufacturers with 3.5, 5.25 and 8-inch drives. Contact your local dealer today.

Or, for the name of the Sumitronics dealer nearest you, call or write:



Sumitronics, Inc.
A Subsidiary of Sumitomo Corporation
580 North Pastoria Avenue
Sunnyvale, California 94086

(408) 737-7683
FAX: (408) 737-9189



Y-E Data. Drives for Consistent Performance.

Cross-Byte is a trademark of Sumitronics, Inc.
XT and AT are registered trademarks of International Business Machines, Inc.
© Copyright Sumitronics, Inc., 1988.

Circle 386 on Reader Service Card (DEALERS: 387)

The Yield Problem

Yield generally falls off exponentially with increasing chip area if defect densities obey a Poisson distribution. To minimize this effect, commercial semiconductor manufacturers, especially those making memory devices, have long since turned to using redundant circuitry on their chips. The success of this method is evidenced by the large difference in both the number of gates integrated and the chip area between regularly structured RAM and random logic processors.

The concept of improving yield by adding redundant circuitry is simple. You include a number of "spare" circuit elements in the system and provide some means of substituting them for other elements that may fail. It would seem that this process could be extended indefinitely to virtually guarantee perfect yield; however, this is not the case.

Both the redundant elements and the substitution means are also affected by processes that may introduce defects. Thus, the overhead associated with interconnecting the substituted redundant elements into the primary system is unavoidable. The more redundant circuitry you add, the greater this overhead becomes. Eventually, the yield of the primary/redundant interconnect wiring becomes the dominant factor in the yield of the system as a whole.

Another parameter you must consider in evaluating redundancy schemes is the resolution that they permit in selecting "good" material. This may be restated in terms of the module size of the substituted components. Very large modules require that you discard a great deal of otherwise functional components as the result of a single malfunctioning element. This is inefficient, since a much larger amount of circuitry will be required to obtain a given yield level than would be needed in a system with smaller modules. On the other hand, systems with larger modules generally require less circuitry and wiring devoted to the primary/redundant interconnect function.

Thus, we can see that there is a trade-off involved in designing a redundancy scheme. It's desirable to choose a small module size for primary/redundant substitution, to minimize the amount of good circuitry that must be thrown away with the bad. However, it's also important to minimize the amount of inter-

connect wiring required to effect the substitution of redundant circuitry into the system, to avoid yield loss from that wiring.

In 3-D

In designing the yield policy for the 3-D Computer, we considered both of these factors. The small size and relative independence of the circuitry in the functional cells make it natural to introduce redundancy at the cell level. Furthermore, the machine's physical structure requires the redundant elements to be

located close to the units they are intended to replace. Finally, the large array size requires a substantial amount of redundancy.

These factors led us to adopt a 2-to-1 redundancy approach for our 32- by 32-element machine, in which every functional cell on each wafer contains two identical circuits.

The primary and redundant circuits have separate I/O pads to make defect detection easy at wafer-level testing. If both primary and redundant circuits are functioning correctly, no action is nec-

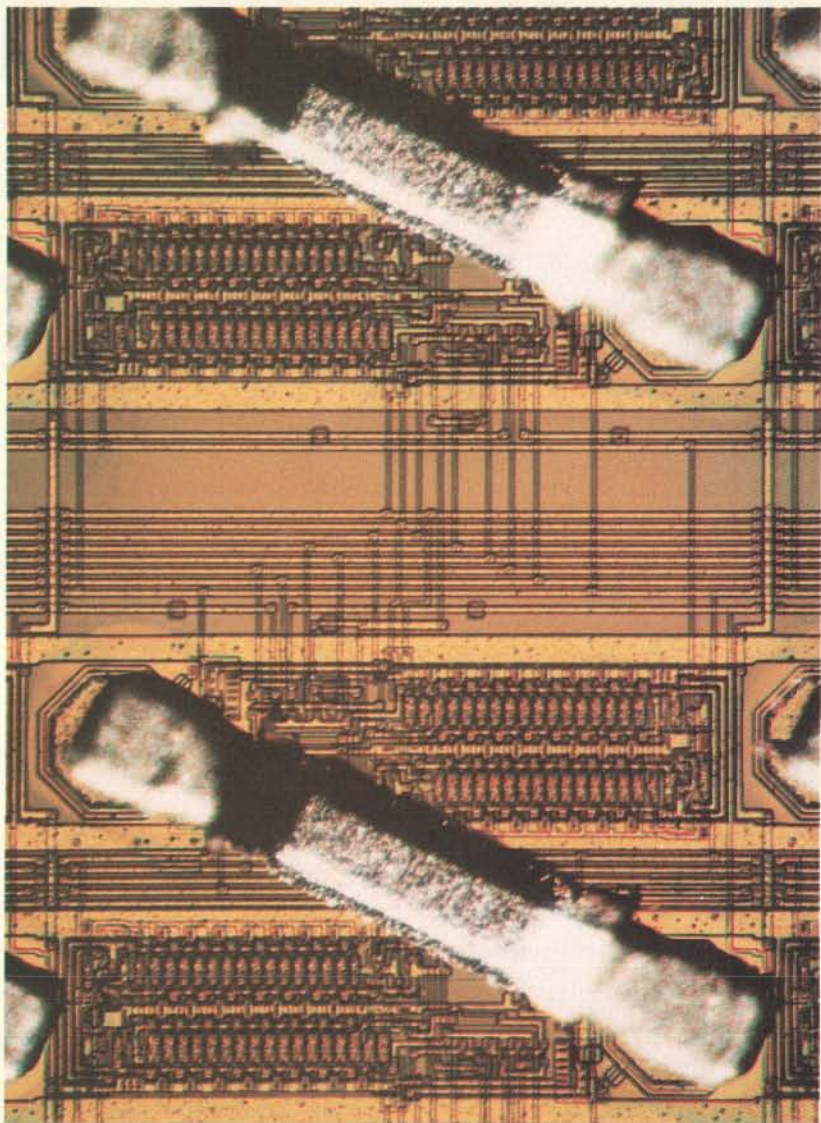

Photo A: A 3-D circuit with microbridge interconnects. The microbridge connects the primary circuit to its redundant counterpart.

essary. If one of the two circuits is faulty, however, it's manually disconnected from its microbridge footpad with the aid of an ultrasonic cutter. The remaining circuit supplies the functionality for that node. If both circuits in any given cell are bad, then the entire wafer is discarded.

This particular scheme, coupled with the microbridges, has subtle benefits. Normally, disconnected redundant circuits are easy to test but require more elaborate steps for repair (need connect capability), while normally connected circuits are easy to repair (cut only) but faults can't be easily diagnosed.

In 3-D circuitry, the primary/redundant circuit pair is connected by a microbridge after the testing is complete (see photo A). Thus, testing is relatively easy because you can test the two circuits independently.

The control circuitry at the periphery of the processor array also needs redundancy to be able to tolerate processing defects. Each row of circuits in a 3-D array is controlled by two identical peripheral-control drivers: one to the east and one to the west, providing 100 percent redundancy to the control circuitry and affording tolerance for at most one open line defect per row. The control signals are distributed over the array with tristate drivers, which can be independently disabled when testing at the wafer level or if the circuitry or tristate driver on one side is faulty.

Although the 100 percent redundancy scheme was proven to be adequate for the 32 by 32 arrays—67 percent of circuits received from the silicon foundry were brought to 100 percent functionality—it's not enough for the larger arrays under development. However, by adding the possibility for primary cells to share the redundant circuits, the yields improve dramatically.

Local sharing is also of considerable importance in dealing with clustered defects. For our 128 by 128 and larger arrays, we will use a 50 percent redundancy approach, but allow each spare to be connected to two primary circuits and each primary circuit to be connected to four spare circuits. The expected yield of 100 percent functional circuit arrays using this approach for both the 128 by 128 and 512 by 512 arrays is more than 90 percent.

on a 4-inch wafer. The 512 by 512 arrays will require 6-inch wafers.

The main factor determining the maximum practical size of microelectronic circuits is the decline of yield with increasing chip area. The large array sizes planned for the 3-D Computer make yield a primary concern. (See the text box "The Yield Problem" at left.)

Working Wafers

By far the majority of the processing occurring in the 3-D Computer takes place in the Accumulator and Shifter wafers. Each cell of these wafers has a 16-bit serial-memory register for data storage, and CMOS circuitry to provide the required logic functions. The cells of the Shifter wafer (see figure 4) not only store data but also perform lateral data transfer between adjacent processors in the array. Each Shifter cell has direct nearest-neighbor communications with others on the same plane and can pass data values north, south, east, or west on the array. Under software control, data within each Shifter cell can pass to any one of its four nearest neighbors in the array independent of the vertical data buses. Thus, multiple planes of data can shift laterally while processing is executing on the stack data buses. These independent neighbor-communications paths enable stack I/O during processing.

The Accumulator circuitry (see figure 5) is similar in complexity to that of the Shifter. The main features of the Accumulator are full adder and a bidirectional shift register. The Accumulator provides the functionality for arithmetic and basic logic. It also participates in normalizing floating-point numbers. For example, two's-complement subtraction is accomplished by allowing a "carry" to be introduced into the least significant bit of the word prior to executing the arithmetic operation. (The bitwise inversion of the subtrahend required by two's-complement subtraction is provided at the output of the Shifter cell circuitry.)

The other three wafer types, while not absolutely essential to the operation of the 3-D Computer, serve to speed up the execution of various algorithms. The Replicator wafer can rapidly propagate data values across an entire array.

The Counter wafer can count the number of occurrences of a single-bit piece of data in a single clock cycle. A normal Accumulator cell could be used for this purpose, but it would require a full 16 clock cycles to tally each single-bit occurrence. This capability is very useful in calculating histogram distributions of

continued

CAPS

Computers And Peripherals

The Complete FAX™

This add-in board allows your PC XT, AT to communicate with Group III facsimile machines throughout the world. **\$325**

The Complete™ Answering Machine

A personal voice mail system that runs completely in the background on your PC and provides not only the basic answering machine functions, but has advanced messaging capabilities as well. **\$259**

The Complete Hand Scanner™

A hand held device for scanning graphic images into IBM or compatible systems. Included software displays the image, allows it to be rotated, cropped and scaled, and can save it in a variety of formats. **\$159**

Genius Mouse™ Package

Includes:

- GM-6 + Mouse • 2 Manuals
- Dr. Halo III • Mouse House
- Menu Maker • Presents

\$45

The Complete PC, manufacturer of the FAX, Answering Machine and Hand Scanner, supplies a two year factory supported warranty. KYE, manufacturer of the Genius Mouse, supplies a lifetime factory supported warranty. All products are trademarks of their manufacturers.

To order call CAPS at (714)727-3403 or send check or money order to:

**24331 Muirlands Blvd • Bldg 4
Ste 206 • El Toro, CA 92630**

Add 3% for charges. Add \$5 handling fee for all orders under \$500. Shipping charged at UPS ground rate. MC, VISA, AMEX accepted.

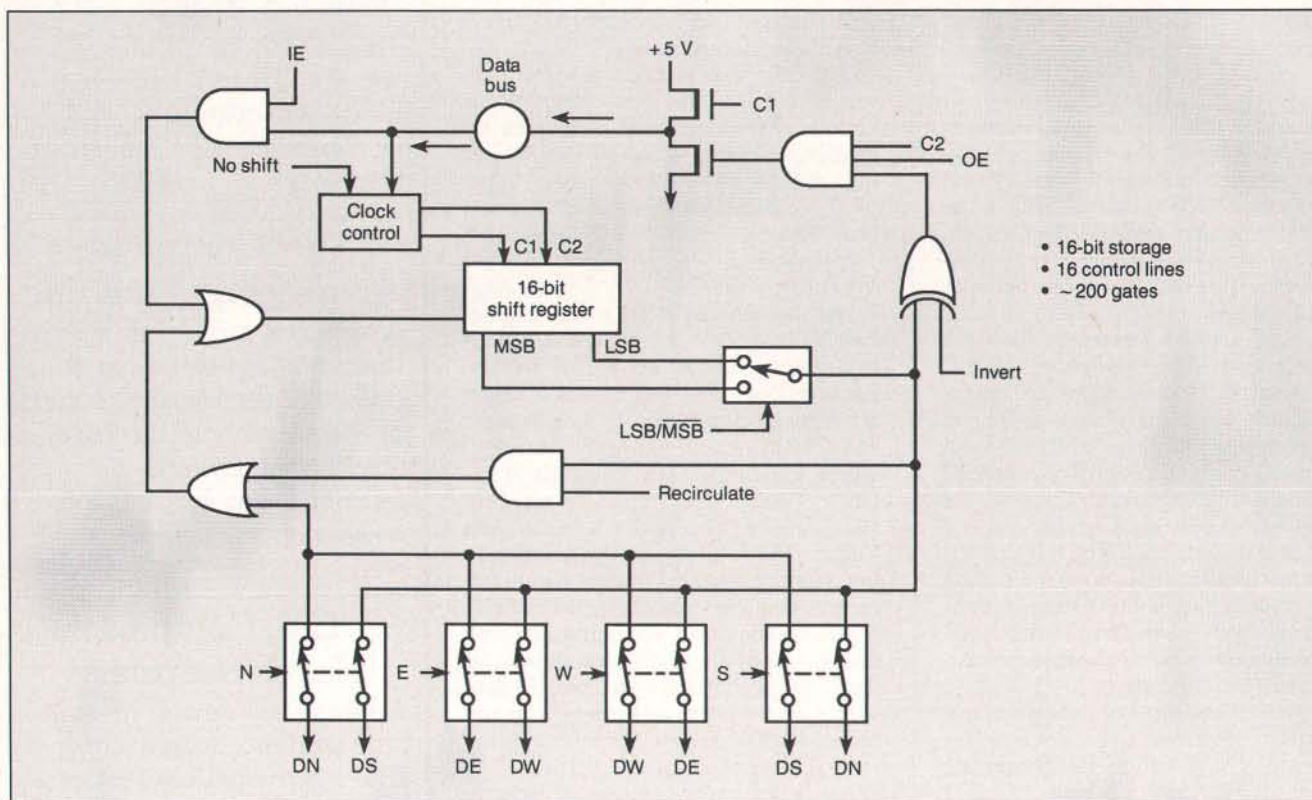

Figure 4: The Shifter wafer type (formerly memory).

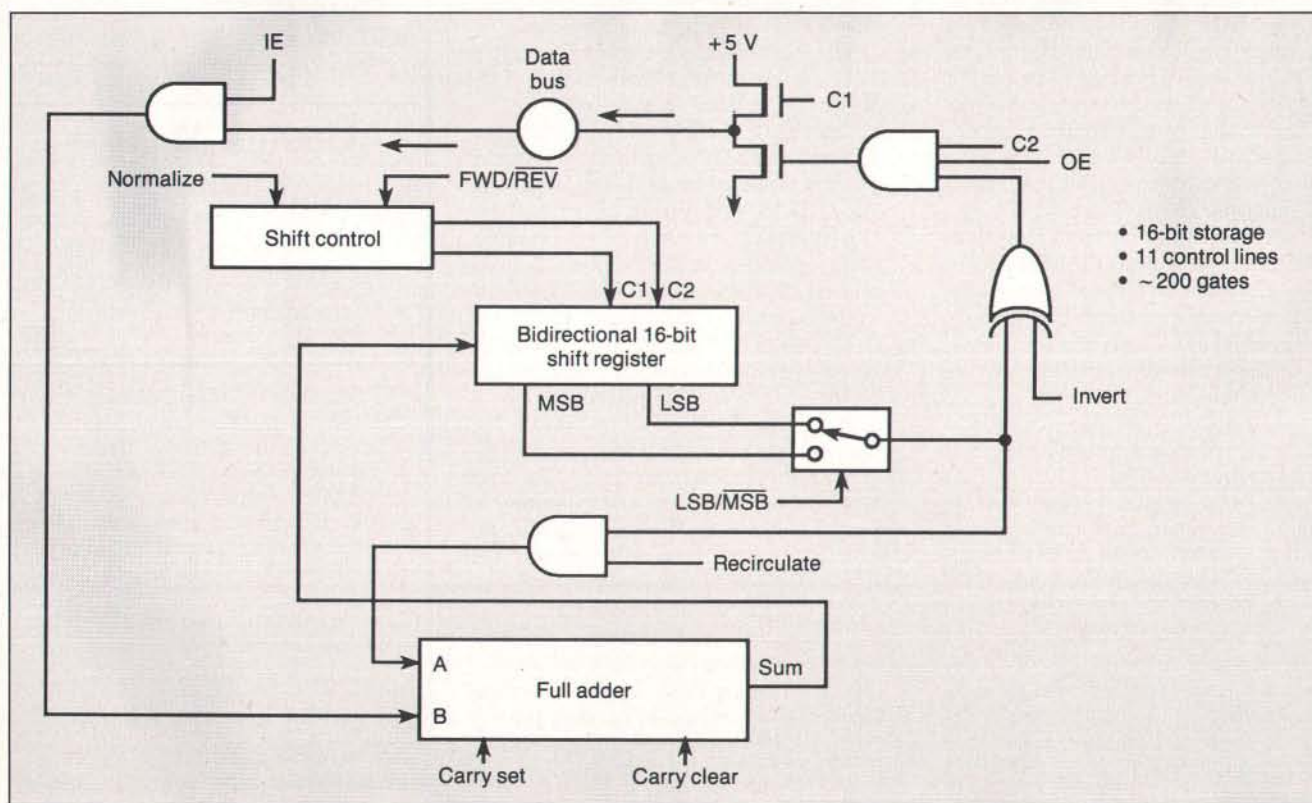

Figure 5: The Accumulator wafer type.

Table 1: Processing times for various operations on a 10-MHz 32- by 32-element 3-D Computer. All times are in microseconds.

Operation	Time
Data move (SHFT 1 → SHFT 2)	1.8
ADD (ACC + SHFT → ACC)	1.8
MULTIPLY (ACC × SHFT → SHFT)	42.2
DIVIDE (ACC ÷ SHFT → ACC)	127.1
SQUARE ROOT (ACC → ACC)	152.6
Sobel edge operator	54.3
256 × 256 matrix multiply	12.0
256 × 256 8-bit histogram	1.7
256 × 256 matrix inversion	10.2

Table 2: Characteristics of existing and future-generation 3-D Computers.

Processor array size	32 × 32 (current)	128 × 128 (under development)	512 × 512 (future)
Circuit size	1" × 1"	2.5" × 2.5"	4" × 4"
Circuit technology (CMOS)	3 μm	2 μm	1 μm
Clock frequency	10 MHz	10 MHz	10 MHz
Processing throughput	600 × 10 ⁶ OPS	10 × 10 ⁹ OPS (390 MFLOPS)	160 × 10 ⁹ OPS (6.2 BFLOPS)
System volume	1.3 cubic inches	2.5 cubic inches	7.5 cubic inches
System weight	170 g.	225 g.	470 g.
System power	1.5 W	500-100 W	100-150 W

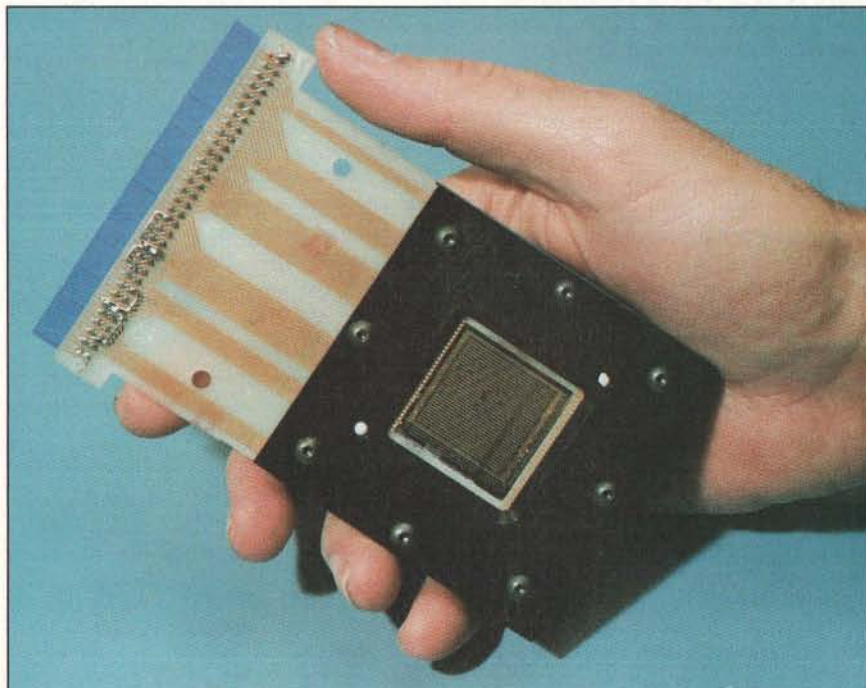

Photo 1: A "hand-held" computer. The 1-inch square in the black section is the 32- by 32-element 3-D Computer.

image data, an operation important in vision processing for image segmentation.

Comparator hardware also exists mainly to speed up operations that could be performed more slowly by the Accumulator circuits. Each cell of a Comparator wafer contains a 16-bit register into which a reference value can be loaded, together with circuitry for performing serial-magnitude comparisons.

It Works!

Additional constraints apply if wafer scale systems are to find widespread use: They must be moderate in cost and size. While state-of-the-art general-purpose supercomputers such as the Cray X-MP can approach the lower end of the processing speeds required—from 10¹¹ to 10¹² operations per second—they fall far short of the size and cost constraints.

Table 1 summarizes performance for several primitive operations, as well as for some algorithms frequently encountered in image processing. Note that the indicated operations are completed everywhere on the array in the indicated time. Consequently, while some operations, such as multiplication, appear to occur relatively slowly, the aggregate throughput of the array as a whole is enormous.

The 3-D Computer (see photo 1) demonstrates the feasibility of the wafer approach. The operational characteristics of the 32- by 32-element machine and the projected characteristics of the 128- by 128-element 3-D Computer currently under construction are summarized in table 2. We hope to have the 128- by 128-element machine running by mid-1990. The projected characteristics of a 512- by 512-element 3-D Computer (planned for mid-1994) are also included. ■

REFERENCES

1. Barnes, G. H. "The Illiac IV Computer." *IEEE Trans. Comput. C-17*, 1968, p. 746.
2. Reddaway, S. F. "DAPQA Distributed Array Processor." *Proc. First Annual Symposium on Computer Architecture*, Florida, December 1973.
3. Duff, M. J. B. "Review of the CLIP Image Processing System." *Proc. National Computer Conference*, AFIPS Press, Arlington, Virginia, 1978, p. 1055.
4. Batcher, K. E. "Design of a Massively Parallel Processor." *IEEE Trans. Comput. C-29*, vol. 9, 1980, pp. 836-840.

Michael J. Little and Jan Grinberg work for Hughes Research Laboratories in Malibu, California. They can be reached on BIX c/o "editors."

Boards and Boxes

Some of the transputer boards and packages available

15-MHz T414
20-MHz T414
20-MHz T800
25-MHz T800
 INMOS Corp.
 P.O. Box 16000
 Colorado Springs, CO 80935
 (719) 630-4000
Inquiry 955.

TransLink Card
 Link II for Mac II.....\$799
 Link SE for Mac SE.....\$299
TM 4-15 (15-MHz T414)
 With 1 megabyte.....\$1599
 With 4 megabytes.....\$3399

TM 4-20 (20-MHz T414)
 With 1 megabyte.....\$1799
 With 4 megabytes.....\$3599
TM 8-20 (20-MHz T800)
 With 1 megabyte.....\$2199
 With 4 megabytes.....\$3999
 Levco Corp.
 6160 Lusk Blvd.
 Suite C-100
 San Diego, CA 92121
 (619) 457-2011
Inquiry 956.

TG2 Multiprocessor
 (Two 15-MHz T414s)...\$1995
For IBM PC and compatibles
 Definicon Systems, Inc.
 1100 Business Center Cir.
 Newbury Park, CA 91320
 (805) 499-0652
Inquiry 957.

Monoputer2..... from \$995
 (One 20-MHz T414 and up to
 16 megabytes)

Monoputer2..... from \$1495
 (One 20-MHz T800 and up
 to 16 megabytes)
Monoputer2..... from \$2395
 (One 25-MHz T800 and up
 to 16 megabytes)
Biputer..... \$3495
 (One 20-MHz T414, one 20-
 MHz T800, and 2
 megabytes)
 (Can get up to 8 megabytes)
Biputer..... \$3795
 (Two 20-MHz T800s and 2
 megabytes)
Quadputer..... \$6000
 (Four 20-MHz T414s and 4
 megabytes)
 (Can get up to 16 megabytes)
Quadputer..... \$8000
 (Four 20-MHz T800s and 4
 megabytes)
 MicroWay
 P.O. Box 79
 Kingston, MA 02364
 (508) 746-7341
Inquiry 958.

New desktop parallel-processing microcomputers

Cogent XTM.. from \$19,800
 Multiple T800s
 (minimum of two)
 Cogent Research, Inc.
 1100 Northwest Compton Dr.
 Beaverton, OR 97006
 (503) 690-1450
Inquiry 959.

Z-1000.....\$19,000
 Up to six 80386s
 Zenith Data Systems
 1000 Milwaukee Ave.
 Glenview, IL 60025
 (800) 842-9000
Inquiry 960.

THE BEST MOST COST-EFFECTIVE STATISTICS PACKAGE AVAILABLE

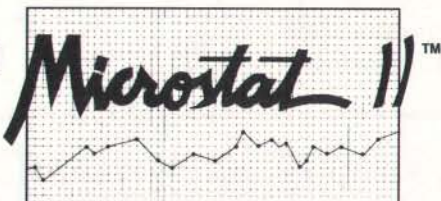

Whether for industry, education, government, or pure research, no other statistics package can compare to Microstat-II in areas of coverage, accuracy, ease of use, and value. Just some of Microstat-II's features include

- Descriptive statistics (mean, standard deviation, variance, kurtosis, skewness, etc.)
- Regression Analysis: Simple, Multiple, Stepwise Multiple, forward and backward
- Correlation Analysis: matrix and cross products table
- ANOVA: Oneway, Twoway, Twoway with replicate
- LSD, Duncan's, Tukey, Newman-Keuls
- Crosstabs and Chi-square
- Hypothesis tests: mean or proportion
- Nonparametrics: Wald-Wolfowitz, Kruskal-Wallis, Wilcoxon, etc.
- Time Series: moving average, centered moving average, deseasonalization, exponential smoothing
- Probability Distributions: Normal, t, F, Poisson, etc.
- Frequency Distributions: value or range.
- Scatterplots (with simple regression)
- Factorials, Permutations, Combinations
- Up to eight times faster than the competition without loss of accuracy
- Online help plus easy to use keyboard or mouse input; no complex command language to learn
- Unequal case sizes, missing data, and aliased data
- Easy to use data entry system with file import capability
- Only three disks—not copy protected
- Expanded user's manual

1-800-952-0472
1-317-255-6476

Requires an IBM PC, XT, AT, PS2 or compatible with 512K of memory 2 floppy disks or a hard drive. Price: \$395.00 with 30 day money back guarantee. Demo available for \$19.95. Please include \$4.00 for shipping. For information, call or write:

ECOSOFT INC.

6413 N. College Ave. ■ Indianapolis, IN 46220



ECOSOFT

TAIWAN'S HIGH TECH TAKE-OFF

A dynamic information industry offers quality, innovation and value.



A dynamic information industry offers quality, innovation and value.

Once the made in Taiwan label usually went with low cost garments and simple electrical appliances. Not any more. Taiwan has moved aggressively into the information industry -- in everything from computers and peripherals to software and advanced telecommunications equipment. From nowhere just a few years ago, Taiwan today ranks as one of the world's largest producers of information equipment.

Much of this gain has been home-grown. Although big name computer and peripheral manufacturers find the island a remarkably congenial production base, the exciting fact about Taiwan's emergence as a major player in this industry has been the development of a large number of local manufacturers and suppliers. Unlike countries like Singapore, which mainly assemble components, the information industry in Taiwan has been built from the ground up -- beginning with such basics as petrochemicals, plastics and fine chemicals.

Local entrepreneurship and innovation, with a strong assist from foreign investors and expatriate Chinese returning with their experience in the U.S., have added to the industry's market driven dynamism and innovative flair. The government of the Republic of China has helped with incentives and R&D support, recognizing early that computers and related products would be a mainstay of the economy in the '90s.



New Boy On The Block

Taiwan's information industry is of recent vintage, really getting underway only around 1980. By 1987, however, with over fifty thousand workers the hardware side alone was producing \$3.8 billion in goods -- up 79% over 1986.

(highlighted quote)

By the end of 1988 Taiwan is expected to be the world's sixth largest hardware producer.

These gains have been matched by an increasing share of the world market. In 1987 Taiwan's hardware producers captured 2.4% of the world market, almost double the 1.45% share in 1986. This made Taiwan the world's seventh largest manufacturer. By the end of 1988 Taiwan is expected to be the world's sixth largest hardware producer.

Taiwan's Hardware Production Surges

Strong Export Growth

Almost all of Taiwan's hardware production is exported -- \$3.7 billion in 1987. Here again the 79% growth rate is far higher than the 10% world average. Expectations are for Taiwan to maintain its fast track pace for at

least, the next three to five years, based on current investment, high productivity and industry competitiveness. Information industry products now account for more than a third of all Taiwan's electronics exports

Exports Pace Information Industry Gains (TABLE 2.)

TABLE 2. Annual ROC Export of Information Products and Components
Value Unit: US\$ 1 Million
Volume Unit: 1,000 Units

	1984 Export Value	1985 Export Value	1986		1987		Growth Rate (%)
			Export Volume	Export Value	Export Volume	Export Value	
Mini Computer	—	—	—	—	0.2	1.8	—
Micro Computer	152	240	1,113	393	1,958	759	93
Disk Drive	86	42	715	71	655	97	37
Printer	23	45	84	41	73	44	7
Terminal	207	225	1,318	317	1,530	414	31
Monitor	319	303	4,852	500	7,022	847	69
Other Peripherals	104	256	—	44	—	80	82
Information Product (%)	891 (88.7%)	1,111 (91%)		1,366 (66%)		2,243 (60.6%)	64
Computer Component (%)	113 (11.3%)	109 (91%)		697 (34%)		1,458 (39.4%)	109
TOTAL (%)	1,005 (100%)	1,220 (100%)		2,063 (100%)		3,701 (100%)	79%

Sources: MIC, Institute for Information Industry, ROC

Looking at the 1987 totals, four clear trends are apparent. The first is the continued importance of

peripherals to Taiwan's export profile. In particular, the island remains one of the world's most important suppliers of video display monitors.

A second trend is the enormous growth in exports of microcomputers and related peripherals. These are

rapidly becoming the mainstay of the Taiwan industry. Between 1984 and 1987 the number of microcomputer makers almost doubled, increasing from 19 to 35. This has brought about a broadening of the marketplace.

Boom In Microcomputers And Color Monitors (TABLE 3.)

A third key trend is the boom in computer component exports. In 1987 these totalled almost 40% of all information industry exports compared to 34% in 1986.

Finally, there is the role of foreign companies, both as manufacturers and purchasers. From the outset, foreign investors have been an important part of Taiwan's information industry. But with the rapid expansion of reliable, innovative home-grown companies, able to meet international quality standards, opportunities for OEM sourcing in Taiwan have greatly expanded. As a result, last year for the first time OEM exports surpassed foreign investor shipments. Foreign computer output and OEM now account for 80% of Taiwan's hardware production, highlighted quote

TABLE 1. Information Industry Production Value of Major World Producers

1987 RANK	1986 RANK	Country	Production Value (US\$100 Million)	Growth Rate
1	1	USA	454	7%
2	2	Japan	212	8%
3	3	W. Germany	81	5%
4	4	Britain	59	9%
5	5	France	53	5%
6	6	Italy	42	4%
7	7	ROC	38	79%
8	10	Singapore	23	71%
9	8	Ireland	20	8%
10	9	Holland	18	5%
11	13	S. Korea	15	63%
12	11	Canada	13	10%
13	12	Hong Kong	8	15%

Sources: MIC, Institute for Information Industry, ROC

TAIPEI

Computex June. 6-12, 1989 

Taiwan has emerged as one of the world's most dynamic commercial centers for microcomputers, a wide range of peripherals, and other computer products. The latest offerings to stimulate worldwide buyer interest are newly developed personal computers that represent an outstanding market value.

It's thus no wonder that Computex Taipei, with over 500 exhibitors from among Taiwan based and international manufacturers, attracts leading buyers from around the globe. You'll want to join them at this sourcing extravaganza.

Organizers:



CHINA EXTERNAL TRADE
DEVELOPMENT COUNCIL

Venue: TWTC EXHIBITION HALL
5 Hsinyi Road, Section 5, Taipei 10509, Taiwan,
Republic of China
Tel: (02)725-1111 • Fax: 886-2-725-1314
Telex: 28094, 10571 TPEWTC



TAIPEI COMPUTER
ASSOCIATION

3Fl., No. 2 Pa Teh Rd., Sec. 3 Taipei, Taiwan, R.O.C.
Tel: (02)7764249 • Fax: (02) 7764410



TABLE 3. Annual Growth of ROC Information Product Market Share Unit: %

ITEM	YEAR	1984	1985	1986	1987
		Micro Computer	19	28	30
Disk Drive		11	5	5	5
Printer		3	5	3	2
Terminal		26	26	24	19
Monitors	Monochrome	33	22	19	15
	Color	8	14	19	24
Total		100	100	100	100

Sources: MIC, Institute for Information Industry, ROC

Last year for the first time OEM exports surpassed foreign investor shipments

The Rise Of OEM (TABLE 4:)

Increasing Software Production

Software production in recent years has also demonstrated significant

growth, with the annual gain averaging almost 50%. Software production in 1986 was valued at \$120 million. This involved some 265 firms -- three times the number in 1981. This reflects the impact of the expanding microcomputer market.

Import Opportunities Open Up

Information products are imported either for local consumers or for manufacturers who re-export the pro-

TABLE 4: Type of Production of ROC Information Products Unit: %

Type of Business Production	1985				1986				1987			
	Foreign Business	Local Business		Foreign Business		Local Business		Foreign Business		Local Business		
		Self Brand	OEM	Self Brand	OEM	Self Brand	OEM	Self Brand	OEM	Self Brand	OEM	
Microcomputer	64	9	27	40	10	28	22	32	9	36	23	
Disk Drive	65	6	29	62	30	0	8	56	16	5	23	
Printer	91	0	9	98	0	0	2	76	0	3	21	
Terminal	63	2	35	69	0	7	24	65	6	7	22	
Monitor	40	4	56	27	15	17	41	18	22	23	37	
Other Peripherals	62	6	32	66	4	5	25	67	4	10	19	
Computer Components	—	—	—	18	2	20	60	21	2	16	61	
TOTAL	58	5	37	36	8	17	39	30	9	20	41	

Source: MIC, Institute for Information Industry, ROC

ducts once installed in assembled units. Because of strong internal and external demand the value of imports climbed 39% in 1987 to \$813 million.

Historically Japan has been Taiwan's major supplier, especially of printers, with the U.S. second. In 1986 the respective market shares were 45% and 33%. In 1987, however, the U.S. began to narrow the gap slightly.

The local Taiwan information market today is worth more than \$500 million for hardware and over \$600 million if software is included. In 1987 more than 70% of the microcomputer sold in the market were produced domestically.

By contrast, although the island produces a wide variety of general purpose monitors, in value terms some 60% of the video monitors were imported, mainly high resolution color monitors. Similarly, while Taiwan makes Chinese and 3270 terminals, the latter for IBM host mainframes, 70% of all terminals were imported.

WHO'S WHO IN TAIWAN'S INFO INDUSTRY

A handy guide to some of the most exciting companies

Typical of the dynamic, home-grown companies reshaping Taiwan's information industry is Chien Hou Electronics, a manufacturer of video display data. Since its establishment in 1981, the company has averaged a 40% growth rate annually.

The company now has seven assembly lines, with production running at 40,000 sets a month. All told thirty different models are offered, including 12", 14" and 15" monochrome monitors, and 14" color monitors. Monochrome monitors account for approximately 70% of the output, with the main markets being Europe and Southeast Asia.

GVC ONLY MAKES THE BEST MODEMS

MINI-MODEM

- * Bell 103/212A, CCITT V.22/22bis
300/1200/2400 bps data transmission
(Model MM-24)
- * Bell 103/212A, CCITT V.21/22
300/1200 bps data transmission
(Model MM-12)
- * Package including modem holder
and carrying pouch



SM-24M 2400 bps Modem with MNP Class 5

- * Bell 103/212A, CCITT V.22/22bis
- * 300/1200/2400 bps
- * MNP error correction Class 5

SM-96M+ 9600 bps V.32 Modem

- * CCITT V.32/22bis/22, Bell 212A
- * 1200/2400/4800/9600 bps Full/Half Duplex operation
- * MNP error correction Class 5
- * Fully AT command set compatible



IBM PS / 2, Zenith, and Toshiba are registered trademarks of International Business Machines Corp., Zenith Data Systems, and Toshiba Inc., respectively.

GVC MODEM SERIES

SM-12	BELL 103/212A 300/1200 BPS EXTERNAL MODEM	PS-12	BELL 103/212A, CCITT V.21/22 300/1200 BPS INTERNAL MODEM FOR IBM PS/2 MODELS 50/60/80
SM-12H	BELL 103/212A 300/1200 BPS INTERNAL MODEM	PS-24	BELL 103/212A, CCITT V.22/22 BIS 300/1200/2400 BPS INTERNAL MODEM FOR IBM PS/2 MODELS 50/60/80
SM-24	BELL 103/212A, CCITT V.22/22 BIS 300/1200/2400 BPS EXTERNAL MODEM	SM-24Z	BELL 103/212A, CCITT V.22/22 BIS 300/1200/2400 BPS INTERNAL MODEM FOR ZENITH LAPTOP COMPUTERS SUPERSPORT AND TURBOSPORT
SM-24H	BELL 103/212A, CCITT V.22/22 BIS 300/1200/2400 BPS INTERNAL MODEM	SM-24T	BELL 103/212A, CCITT V.22/22 BIS 300/1200/2400 BPS INTERNAL MODEM FOR TOSHIBA LAPTOP COMPUTERS T1100 PLUS, T1200, T3100 AND T5100



Circle 407 on Reader Service Card

GVC CORPORATION
14F, 658, Tun Hwa S. Rd.,
Taipei, Taiwan, R.O.C.
Tel: (02) 755-2226
Fax: (02) 755-2413
Telex: 13233 GVCCORP

North America Office:
41 Bergenline Ave, Westwood, NJ 07675
Tel: (800) 243-6352, (201) 666-1443
Fax: (201) 664-7736
Sales Office:
California,
Tel: (408) 435-5076, Fax: (408) 435-5075
Canada,
Tel: (416) 738-9300, Fax: (416) 738-5563

Chien Hou believes quality control and R & D are basic to the company's pent success. The R & D effort is now concentrating on a 19" CAD/CAM monitor in color and monochrome that should be ready by early 1989.

For its display data Chien Hou has bypassed developing a multi-sync monitor, opting instead to offer a VGA Plus monitor that incorporates multi-sync resolution with the firm's DATAS VGA Plus Card. This allows the user to have VGA functions at a cost less than that of a multi-sync monitor.

Chien Hou's CGA units will display 64 colors beside green and amber. The EGA version's interfaced resolutions are 640 x 200 and 640 x 350, with a dot pitch of 0.31mm.

Datacomp has twenty engineers for product R & D. The turn around time for customer-designed (or assisted) products averages four to eight weeks. The company also has its own designs and innovations. For example, it has managed to reduce the size of a standard IBM keyboard by over 80%. Membrane keyboards have also been developed and will go into production this month.

Only four years old, Datatronics Technology is already one of Taiwan's leading manufacturers of computer peripherals and data communications products. The company employs 80 staff, of whom 30 hold Masters and B.S. degrees in computer science and data communications. A factory twice the size of the company's present facility is now under construction.

Datatronics is especially strong in modems, producing 250,000 annually. Most of Datatronics modems are sold under the Discovery brandname, although the company welcomes private labels and customer designs.

The auto-dial, auto-answer modems available from Datatronics are in a series of standalone, pocket-size and card version models, meeting Bell standards and CCITT recommendations for dial-up and leased-time operations in both synchronous and asynchronous modes, having been granted FCC registration and certification, as well as PTT homologation in several other countries, the modems are permitted for direct connection on telephone lines and networks.

Besides modems, Datatronics also produces pocket-sized acoustic couplers. The size of a cigarette package, these couplers are suitable for use with portable computers for data communication in hotel rooms or public telephone booths, where direct connection to the telephone line is not possible.

Digitech Computer is also only four years old. It is part of the \$300 million diversified Chia Ho group, whose activities include chemicals, textiles and financial services, as well as computer products.

Digitech produces fax cards, handy scanners, terminals, emulation cards and printer converters. For example, the company's new Digifax CWS-18GF is a personal computer-based, CCITT Group III compatible fax card. It consists of software, a special board and an auto box to be installed on IBM PC/XT or compatibles. It has passed FCC part 15 and 68 testing and has been approved by Taiwan's PTT.

Digifax's CSW-18GF is a powerful computerized facsimile system. It supports high speed communication fax, image processing, data processing, file transfer and electronic mail box. Instant-timing multi-message and multi-address transmission allows a maximum of 16,000 messages to be stored and transmitted simultaneously.

Godspeed — data missing/data to come. By comparison Goodway is one of the Taiwan industry's older data communications equipment manufacturers. Established in 1974 it has sales on the order of \$6-8 million a year.

The company's product range includes computer cable data switches, APP-NET and plus (phone net compatible), SCSI terminators, and Apple Talk compatible for the last two years kits.

User-friendly, reliable, competitively priced products are the keys the six-year old Guis's success. This approach is reflected in the company's sales staff — mainly drawn from the computer science and business administration fields, most with MBA or MIS degrees from the U.S. This allows sales staff to react quickly to the needs of the marketplace and feed that information intelligently to the company's R & D staff.

Guis has two main product ranges. The first is telecommunications products including intelligent telex terminals, PCFax systems fax/scanner/copiers, plain paper fax machine and personal fax machines. The second line involves such image processing equipment as desktop scanners for mid-range applications and a flat-bed, book-type professional scanner and a Microsoft Window-based software package for image processing and editing.

Guis's intelligent telex (Telewriter 841) incorporates the functions of telex, TUX, DDD, word processor and electronic mail into a desktop unit. The WINNER Microsoft Window-based package can support the image file formats of Windows Paint, Paintbrush and other popular graphics programs. Scanned images may be merged with images in memory and freely mixed with text on the screen.

GVC is one of Taiwan's more important telecommunications and desk-top publishing device manufacturers. Established in 1979 the company has achieved strong growth by concentrating on the development and integrated design of original and state-of-the-art computer peripherals. The company has 200 highly-trained technical staff, as well as advanced design, testing and production equipment.

GVC currently offers a line of Hayes compatible 1200 and 2400 baud modems in external, stand-alone models, including a pocket-size model; as well as internal plug-in models, for both PC and PS/2 systems. All are compatible with Bell and CCITT standards. It also has a new 9600 baud stand-alone modem with V.32 compatibility and the full Hayes-AT command set.

In addition to modems, GVC has developed desktop publishing peripherals. The company's first entry is an optical mouse with a high resolution of 250 dots-per-inch. By the end of this year, GVC will also introduce a handy scanner and a PostScript Laser Printer controller.

GVC is particularly interested in meeting the needs of OEM customers who need to cut production costs to remain competitive. GVC believes it is the best possible off-shore partner, for design as well as production, especially for companies that need to come out with innovative new products.

It welcomes customer-designed products because its engineering team is experienced with all phases of microcomputer R & D. This gives it the flexibility to cope with design changes and engineering changes or

TATUNG SELLS SOLUTIONS

WE PROVIDE

TATUNG PERSONAL COMPUTERS (8088 • 80286 • 80386)

Most Suitable for:

- * Personal Computing System
- * Desktop Publishing System
- * Workgroup Server System
- * Communication System
- * CAD/CAM System

TATUNG COLOR & MONO MONITORS

- * CGA, EGA, VGA, MDA, MGA, MCGA
- * Portrait Monitor for DTP
- * Monitors for CAD/CAM Purpose
- * Display Size: 17"-19"
- * Resolution up to 1K x 1K

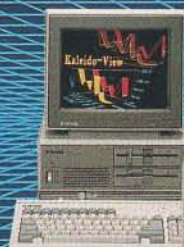

(TCS-3000T)



(TCS-4000)



(TCS-7500)



(TCS-8000)



(TCS-7000)



(TCS-8600)

**WE
ARE THE
WORLD**

THE TATUNG FAMILY SOLUTION



TATUNG

Quality/Reliability/Commitment

Please Contact:

HEAD OFFICE : 22 Chungshan N. Rd., Sec. 3, Taipei, ROC. Tel: (02) 592-5252, Tlx: 11348 TATUNG, Fax: (02) 591-5185

TATUNG Co. of
America, Inc.
Los Angeles
Tel: (213) 979-7055
Tlx: 910-346-6710
Fax: (213) 637-8484

TATUNG Science and
Technology, Inc.
San Francisco
Tel: (408) 435-0140
Tlx: 285462 TSTI UR
Fax: (408) 435-0138

TATUNG(U.K.) Ltd.
United Kingdom
Tel: (0952) 613111
Tlx: 35292
Fax: (0952) 615555

TATUNG International
(Deutschland) GmbH
West Germany
Tel: 02104-30030
Tlx: 8589369
Fax: 02104-300310

TATUNG Co. of
Japan, Inc.
Tokyo
Tel: (03) 545-2969
Tlx: 12522504 TATUCO J
Fax: (03) 545-3155

the production line, preventing costly delays.

Honotron is a peripherals manufacturer. This month, the company will announce a new Key-Mouse at the Comdex show. The Key-Mouse offers the advantage that it can be connected directly to the keyboard, without the need of any additional port. Honotron also offers computer keyboards for IBM PC/XT/AT and PS/2 and compatibles. These are of the membrane type and have a real two-step tactile feeling.

Labway is just a year old, but already has sales pushing the million dollar mark. Its products include 5.25" external FDDs for the entire PS/2 family; mice (two-button, Din connector) again for the whole PS/2 family; RAM cards for PS/2 model 50/60; mice (tree-button, BS-232 connector) for PC-XT and AT; NEAT Motherboards; and NEAT BIOS.

Labway's external FDDs can read/write and format both 360kb and 1.2 mb; and require no expansion slots, interface card or power supply. The mice offer high tracking speed; provide a test program and menu creator; and are 100% IBM mouse compatible.

Lyi-Cheng Enterprise is a good example of the way Taiwan companies grow and adapt to changing market conditions, acquiring new skills and technology along the way. Founded in 1877, the company began as a producer of radios, TVs, and arcade game machines.

Since then, Lyi-Cheng has grown 75-fold in terms of capital, built a new modern production facility and shifted to XT/AT (8088, 80286, 80386) personal computers and peripherals. Total production capacity now is 16,250 PCs a month.

Maxan Industrial began operations two years ago as a sourcing agent for companies located in Singapore and the United States. Soon thereafter, the company moved into manufacturing itself. Today Maxan is an integrated company with the resources to engineer, manufacture and market technically advanced, high quality, electronic computer equipment.

Maxan views its main strengths lie in strong P & D and manufacturing divisions. Its focus is in data communications, but it also has experience designing other products for OEM clients.

In product development the company is oriented towards non-systems hardware. It emphasizes data transmission and PC-related add-on products. It has in-house electronic circuit and mechanical design capability, as well as some ability in software and firmware development.

On the manufacturing side Maxan's strengths include: manual assembly of electronic board level and basic box products; quality control and assurance; production process design and engineering; non-temperature cycling burn-in; functional testing and diagnostic tests; and parts procurement.

Products developed and carried by Maxan include dial-up 2400 BPS Hayes-compatible modems; group 3 compatible 9600 BPS fax cards; ethermax control cards IEEE 802.3 compatible control cards for ethernet LAN; and IEEE 802.3 compatible ethernet local repeaters.

Founded in 1981, RCS Technology Corporation is a well-established manufacturer and exporter of anti-static, anti-radiation (VLF) products. It is a subsidiary of Taiwan's Daikyo Petrochemical Company.

RCS Technology's VDT filters eliminate glare and reflection; enhance picture contrast; block VLF radiation 98.9%; and dissipate static electricity 100%. The filters provide the highest resolution screen available, virtually and dust accumulation, are effective on both color and monochrome VDTs and are available for curved and flat monitors.

Real Time Industrial's RTA-03E Multi-RS-422 serial adapter (4 ports) is designed for IBM PC AT or compatible computers. It offers an asynchronous communication protocol and can use an EIA 422 industrial standard interface. The communication distance is up to 3000 feet, with a baud rate of up to 58K BFS.

Real Time's fax card is compatible with PC/XT/AT/386 or PS/2 model 10. FCC approved, it is compatible with CCITT V.29 and V.27, TER, T4 and T30.

Real Time also offers the RTX-02B B255 plus card, a programmable input/output interface for PC/XT and PC/AT. It is suitable for design and experimentation. It contains 96 I/O lines; six independent 16 bit counters each with a count rate of up to 5 MHz; and two programmable interrupt chips.



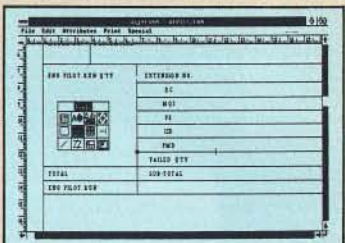
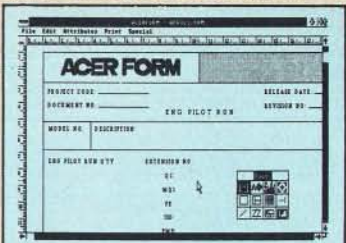
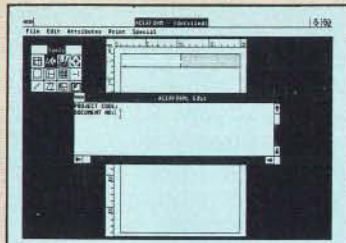
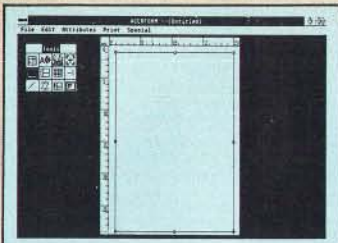

1. Start with clean page at 1:10 p.m.

2. Type in text through Edit window.

3. Load image and add lines.

4. Add lines to form table.

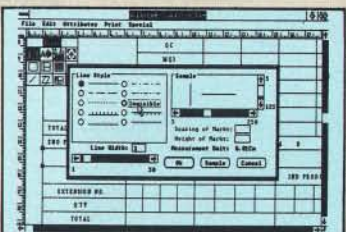
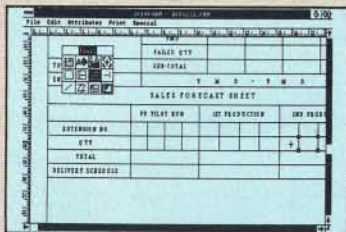
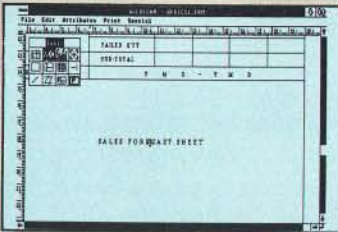

5. Type and place sub heading.

6. Use tool 7 to add multiple lines.

7. Make connecting lines invisible.

8. The finished form in Reduced View at 1:24:32 p.m.

Create a professional form in less than 15 minutes!!!

ACERFORM is an MS-Windows application. All the advantages you enjoy and rely on from Windows, like ease-of-use and excellent graphics, are at your fingertips when you use ACERFORM. With ACERFORM, lines can be as thin as a strand of hair or as thick as your pencil. For frame and text backgrounds you have 16 patterns to choose from.

Corporate logos and other images are easily loaded and sized. With SoftFont, character styles come in a wide variety of shapes and sizes -- and the fonts you select are shown right on the screen, just as they appear on your printed form.

ACERFORM enables both mouse and keyboard users to develop a form efficiently without dealing with complicated screens and strange codes. The command menus and form tools complement one another to make form building a logical and simple process.

ACERFORM supports most laser printers and is for use on IBM PC/XT/AT/386 & PS/2 compatible systems. Write us today for more details.

USING ACERFORM YOU CAN:

- Merge data from external sources as you print.
- Easily draw lines and frames and place them on your form accurately.
- Load, place, crop and size images accurately.
- See the actual form and all font typefaces and sizes on your screen as you work.
- Fill out the form partially, or not at all.

Selectable line widths range from 0.5 cm to .01 cm.

ACER FORM

Actual loaded image.

ACER FORM

Loaded, resized image.

ACERFORM offers a comprehensive toolbox with 12 tools to aid you in drawing lines, loading and cropping images, and typing or loading text. There's also a tool especially for block operations, such as saving a part of your form for loading into another form or uniformly editing parts of your form.

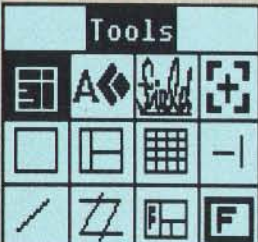

The ACERFORM Toolbox offers an unprecedented range of form tools. **Circle 421 on Reader Service Card**
Worldwide inquiries, contact:

ACERFORM's text editing feature allows you to utilize data from several sources. You can key in directly from your keyboard or load data stored in WordStar, dBase III Plus and Lotus 1-2-3.

The Third Wave Publishing Corp.
Dept. K, 977 Min Sheng East Road, Taipei 10581, Taiwan, R.O.C.
TEL:886-02-763-0052 TLX:29335 THIRDWVE FAX:886-02-765-8767



For inquiries in the U.S. Contact:

Vault Corporation
CALL: 1(800)445-0193
In CA: 1(800)821-8638
Major credit cards accepted.

US\$299
Suggested retail price.

The Third Wave is a member of the ACER Group

Royal Information Electronics (TRL) has been making quality monitors for ten years. Emphasizing product quality and reliability, as well as after-sales support TRL has twenty quality control and quality assurance engineers in its 300-man workforce.

The TRL monitor series features a streamlined, elegant design and offers complete IBM PC/XT/AT/PS2 compatibility. The enhanced high resolution, high contrast, dark tint, non-glare screen gives sharper images. The tilt and swivel base allows easy adjustment, with readily accessible control switches.

The Taipei Computer Association is one of the major driving forces behind Taiwan's emergence as a major player in the world information industry. Founded in 1974 with less than 30 members, today the association has more than 1700 members, including a number of major foreign companies. Currently chaired by Stan C. J. Shih, president of Acer, the association's activities range from software development and market research to anti-counterfeiting and international cooperation.

Part of the association's mandate is to expand worldwide recognition of the Taiwan information industry. This involves both encouraging foreign firms to locate offices and production facilities on the island; and helping gain approval for Taiwan-made products.

In order to encourage foreign investors, the association actively works with the ROC government and the Institute for the Information Industry to improve the overall investment environment. It also helps foreign firms identify local product-makers for sourcing.

The association sponsors two trade shows annually. Each June it organizes Computer Taipei, the largest computer products show in Taiwan. This year the show was attended by 4,000 foreign buyers and logged more than \$7.2 million in sales.

In April the association stages Softex Taipei as a venue for software developers and buyers. The show includes seminars and displays of the latest software designs.

The association has been a major force in Taiwan's anti-counterfeiting effort. Recognizing the cultural aspects of the problem where imitation traditionally has been regarded as a form of praise — the association has sought to raise public awareness of the importance of intellectual property rights.

Taiwan First Line Computer & Cable Corporation is another comparatively young company. With an up-to-date, fully integrated production facility and a corporate culture emphasizing quality control, the company seeks to offer customers better quality at competitive prices, with on-time delivery. Founded in 1985, it now has sales in the \$4 million range, from cables, data switch-boxes, gender changers and similar products.

Specific products include PS/2 serial cables; Appletalk/Macintosh cables; phonenet; Appletalk adapter bits; and SCSI terminators.

Tatung is not only Taiwan's oldest electronics and computer company, it is also the biggest, with a true worldwide capability. It operates under its own brandname as well as on an OEM or subcontract manufacturing basis. Total sales, including home appliances and industrial equipment, came to \$1.4 billion in 1987.

Tatung's product range is enormous, by Taiwan standards. For example, it produces 8088/8086, 80286 and 80386 based micro-computers and workstations; as well as disk control, graphic control, memory expansion and LAN add-on cards. In terminals, Tatung makes ANSI, ASCII, and ANSI/ASCII/PC terminal emulations; VT-220, DG-200, ADM SA/31, and Wyse 50/60 emulations.

In monitors Tatung produces monochrome (MDA, MGA and MCGA compatible), color (CGA, EGA and PGA compatible) and plasma display units. It manufactures dot matrix printers; as well as engines and controllers for laser beam printers. Tatung also manufactures FDDs, HDDs, keyboards and mice, power supply units (linear and switching mode), CRTs and telecommunications equipment.

Looking ahead, Tatung is working toward more high end systems products. It seeks further integration of Tatung's system design and ASIC design technology. It wants continued broadening of CAD/CAM applications and an increase in productivity and quality in design, engineering and manufacturing electromechanics. It aims at the further integration of computer and communications technology, as well as increased application of surface mounting technology.

Founded in 1983, Team Technology helped pioneer the U.S. market for Taiwan high tech products, introducing its modems at the 1984 Comdex show. The response from this initial foray was so overwhelmingly positive the company immediately drew up a world marketing plan. In subsequent years Team modems were subjected to extensive product testing all over the world. Current production is 10,000 units a month.

In Team's product range are 2400 and 9600 BPS with MNP protocol modems. The "Micro 1200" is a specially designed pocket modem without battery or AC adaptor required. Its size is only 2cm x 7cm x 11cm. All Team modems are provided with Ball and CCITT protocols and are Hayes command compatible.

Quality control is taken seriously by Team. From IQC, ICT (in circuit, test with HP-3065), burn-in test (48-hours), function test, AQL test to QA test, every step is performed thoroughly. The company has no minimum orders and welcomes private label and custom-designed orders.

Sixteen of Team's 65 staff are in R&D. Products under development include a PS/2 modem (2400 BPS) to be announced this month; a V.32 modem including V.21 to V.32 and Bell 103/212A, which will be announced in early 1988; and a LAN card, a Teamnet/Ethernet interface card available next month, which will be able to run directly Novell's Netware/86, /286 or ELS by selecting the NE1000 software driver

A subsidiary of Acer, one of Taiwan's largest and best-known computer and peripheral manufacturers, the Third Wave Publishing Corporation is the island's biggest software, peripheral and publications company. Sales last year were \$5.8 million and should exceed \$10 million this year.

Third Wave's product line-up includes the Generation Adaption Products (GAP) series of peripherals, designed to provide the computer user with the means to bridge the technology gap between different technology systems — for example in system upgrades and the transport of data between incompatible systems. Initial products on the market are a line of external drive consisting of six models covering all major types of PS/2, PC, laptops, portables and Commodore applications, for both 3.5" and 5.25" floppy disk media.

The automation industry represents the next area where computer technology finds increasing applications. Third Wave has it

SmarTEAM™

Offers A Choice



U. S. A.
PDM
(713) 488-8830
MicroAge
(206) 746-8045
SYSCOM
(516) 765-0570

CANADA
BUDGETRON INC.
(416) 673-7800

NORWAY
PROFESSIONAL
SYSTEM A/S
(02) 253350

BENELUX
COMPUTATA BV
(0) 73-422045

ITALY
DATATEC
(06) 8321-213

W. G.
RVS
(089) 35-10-071

FINLAND
MIKROMERIOY
(90) 550-155

ICELAND
TAEKNIVAL
(1) 68 16 65

SWEDEN
DATADRAGET
(08) 286 262

GREECE
SMM•ABEE
(01) 9715007

SINGAPORE
PET
292-9155

SAUDIARABI
AL-JASSIM
(3) 832-2148

PHILLIPINE
RANK
(2) 40-2391

NEW PRODUCTS:
ETHERNET LAN CARD
(10M)
V.32 MODEM
SEE US AT
COMDEX/FALL '88
BOOTH #3036

SmarTEAM The Smart Choice

SmarTEAM 2400

- * Bell 103/212A, CCITT V.22/22 bis
- * Auto dial, auto answer, auto speed selection
- * ASYN/SYN operation
- * Fully compatible with Hayes.

SmarTEAM 2400 MNP

- * Sophisticated error checking and error correcting
- * Provided MNP mode and NON-MNP mode.
- * Compatible with Hayes AT command.
- * ASYN/SYN operation.

SmarTEAM 9600 PLUS

- * Utilizes the latest MNP class 6 to give error free data transfer.
- * Cheaper telephone bills with the MNP data compression provides throughput of up to 19200 bps with 9600 bps link.
- * Battery-backed CMOS RAM-preserves configuration against power failures for up to 30 days.
- * Communicates with any MNP or NON-MNP modem which supporting Bell 103/212A, CCITT V.22/22bis/V.27/V.29 modulation standards.

MNP is trade mark of MICROCOM Inc. HAYES is trade mark of Hayes Microcomputer Product, Inc.



TEAM TECHNOLOGY INC.

10 Fl., No. 270, Nanking E. Rd.,
Sec. 3, Taipei, Taiwan, R.O.C.
Tel: (02)741-4270 (5 Lines)
Fax: 886-2-7712985
Telex: 19725 TEAMTECH

SmarTeam

U.S.A. SALES AND SERVICE CENTER

SmarTEAM INC.

19205 Parthenia St., Suite #J, Northridge, Ca. 91324
Tel: (818)886-9726 Service No: (818)886-9729
Fax: (818)886-6731

Circle 420 on Reader Service Card

Keyless Data Collection Series to facilitate the processing of information at all levels of computerization. The series provides the user with a time-saving and cost-effective method of data input in a manner that is virtually error free. The company's bar-code reader liner under this series presently consists of four models: a keyboard emulator, an RS232/422 interface reader, a portable, hand-held reader and an on-line reader expendable to a 128-unit network.

Most recently, Third Wave released ACERFORM, a desktop form-composition software using the Microsoft Windows

format. Feature for feature, it offers the best software of its kind in the market, but is remarkably easy to learn and convenient to use.

Founded in 1984, within a year Ostempor Electric's name appeared in Byte in connection with Taiwan computer manufacturing. Ostempor's president and chief engineer, Johnny Chen, takes credit for creating the first legal IBM PC-AT compatible computer in Taiwan.

Since the Ostempor has gone on to other achievements. In 1986 it produced a 12MHz AT-compatible motherboard with built in I/O ports (Model 2000 A/B), anticipating the IBM PS/2 system. In 1987 Ostempor introduced a

16 MHz AT-compatible all-function motherboard.

This year Ostempor's successes have included its model 5000X cabinet. This sleek slim, newly designed cabinet is only 37.5 x 11.5 x 9 cm. The 5000X can be fitted with one 5.25" and three 3.5" drives, for a total of four. It is also fitted with six horizontal expansion slots. Users will especially appreciate the triangular front panel, which is inclined for easy viewing.

Four year-old P & C Shiten Enterprise concentrates on computer R & D and manufacturing, while sister company, Paoku P & C focuses on marketing and sales. Together the two are pushing toward a \$21 million turnover this year.

P & C Shiten is currently active in IBM compatible PC/XT/AT computers and peripherals as well as laptop computers with a CGA function. By the end of the year they will also be producing laptops with EGA and VGA functions.

Paoku is the exclusive distributor for a number of European companies, including Svenska Micro Data of Sweden; Erni-Compro and Panatronic Fareast of Switzerland; C. S. E. D. of Belgium; ACM World Trade Center of Holland; I. E. E. of France; and Edicon sult SRL and Comprel of Italy.

Together the two companies also supply a number of major information industry giants, such as Matsushita.

MODEM

BELL 103/212A

CCITT V21/V22/V23/V22 bis

1200, 2400, 9600 BPS

AUTO-DIAL, AUTO-ANSWER

HAYES™ COMPATIBLE

MNP ERROR CORRECTION

FCC & PTT APPROVAL



•Discovery 2400P Port Modem™
(Pocket-Size Portable Modem)



•Discovery 2400C Modem
Dial-Up/Leased-Line/Sync/Asyn



•Discovery 2100 Acoustic Coupler
(Pocket-Size Acoustic Cup Set)



•Discovery 2400HK Modem
Dial-Up/Leased-Line/Asyn



DATATRONICS

Datatronics Technology, Inc.

172 Nan-King E. Rd., Sec. 5, Taipei 10572, Taiwan,
Phone: (02) 762-3202 (3 Lines), (02) 768-6262 (3 Lines)
Telex: 28440 DIXMODEM Fax: 886-2-764-0614.

In U.S.A. please contact:
Sunhill Inc. TEL:(206)-575-4131



IBM PS/2 Model 30 Compatible



MICRO AT



TOWER 386

We Are Offering Full Range PCs
With Better Quality, Service, And...
of course The Better "Price"



SLIM XT

SEE US AT COMDEX SHOW
BOOTH NO.871 (WEST HALL)

IBM PS/2 MODEL-30 AND AT ARE REGISTERED TRADEMARKS
OF THE INTERNATIONAL BUSINESS MACHINES CORPORATION

LYI-CHENG ENTERPRISE CO., LTD.
NO. 260, CHUN-YOUNG RD., NAN-KANG, TAIPEI, TAIWAN, R.O.C.
TLX: 12222 LYICHENG FAX: 886-2-7821815 TEL: 886-2-783-3847

15" BIG MONITOR, WITH BIG CHARACTER CLEAR AND STEADY FOR EYE PROTECTION

- 14" 19" COLOR
(CGA, EGA, PLUS, VGA, MULTISYNC)
- 14" MONO
(SINGLE, DUAL, VGA)
- 15" MONO
(SINGLE, DUAL, VGA, MULTISYNC)
- 19" MONO
(SINGLE, DUAL, VGA,
MULTISYNC)

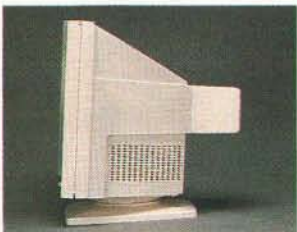

15" MONO VGA
OVEN SCAN REVES



14" COLOR VGA MONITOR
AND VGA PLUS MONITOR
(HOR: 31.5K / 35.2K)



NEW MODEL



CHIEN HOU ELECTRONICS CO., LTD.

172-1 CHUNG CHENG RD., TA YA HSIANG 4281C TAICHUNG HSIEN, TAIWAN, R.O.C.
TEL:(045)672770-9 FAX:(045)672700 TELEX:51149 CHIENHOU
TAIPEI OFFICE/ TEL:(02)7252981-2 FAX:(02)7251993

SMART-CABLEMAN®

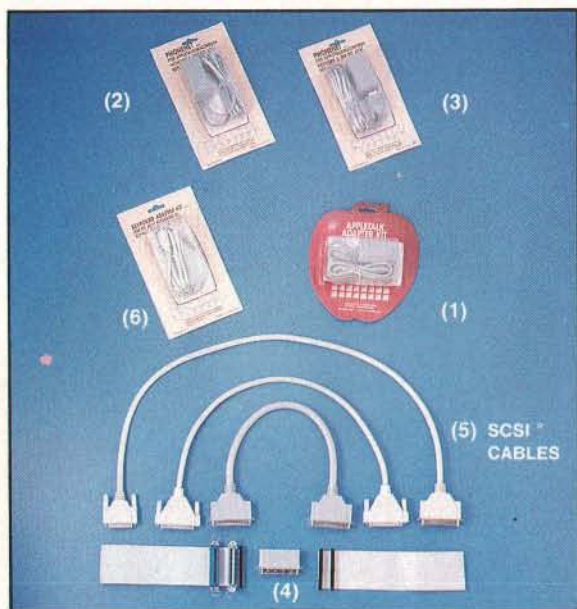

APPLETALK/MACINTOSH NETWORK HARDWARE

FIGURE (1) APPLETALK ADAPTER KIT

KS-A-001 APPLETALK ADAPTER FOR MACINTOSH
KS-A-001P APPLETALK ADAPTER FOR MACINTOSH PLUS
PATENT IN TAIWAN

FIGURE (2) & (3) PHONENET® KIT

KS-A-002 PHONENET KIT FOR MACINTOSH
KS-A-003 PHONENET KIT FOR MACINTOSH PLUS
PATENT IN TAIWAN

FIGURE (4) SCSI® TERMINATORS

KS-S-004 MALE TERMINATOR FOR MACINTOSH NETWORK
KS-S-005 MALE TO FEMALE TERMINATOR FOR MACINTOSH NETWORK
PATENT IN TAIWAN

FIGURE (5) SCSI® CABLES

EXTENSION CABLE, HARD DISC CONTROL CABLE, FLOOPY DISC CONTROL CABLE, INTERFACE DATA CABLE -- ETC.

PS/2 KEYBOARD ADAPTER KIT

FIGURE (6) PS/2 KEYBOARD ADAPTER KIT

KS-I-005 PS/2 KEYBOARD ADAPTER FOR PC AT/XT KEYBOARD TO FULLY COMPATIBLE WITH PS/2 SERIES
PATENT IN TAIWAN

OUR INTEGRATED PRODUCTION FACILITY AND STRONGLY QC PROCESS, TO OFFER "ZERO DEFECT" "ON TIME DELIVERY" AND "REASONABLE PRICE", ON FULLY PRODUCT RANGES -- CABLES, GENDER CHANGERS, DATA SWITCHBOXES, -- ETC. PLEASE CONTACT US FOR DETAIL.



AGENT WANTED

TFL GROUP LEADER:

TAIWAN FIRST LINE COMPUTER & CABLE CORP.

P.O. BOX 12472 TAIPEI, TAIWAN, R.O.C.

FAX: 886-2-5910004 (REP), 886-2-5942209 (REP)

TELEX: 29393 TFLKSLEE TEL: 886-2-5925192 (REP)

PHONENET®, SCSI®, →® ARE REGISTERED MARKS OF TFL GROUP

PC AT/XT & PS/2 ARE REGISTERED MARKS OF IBM.

APPLETALK, MACINTOSH AND MACINTOSH PLUS ARE REGISTERED MARKS OF APPLE COMPUTER, INC.

GUIS

NEW ANNOUNCED
Meet you in the
COMDEX/Fall '88 CASHMAN FIELD CENTER
Booth A442

PERSONAL FAX

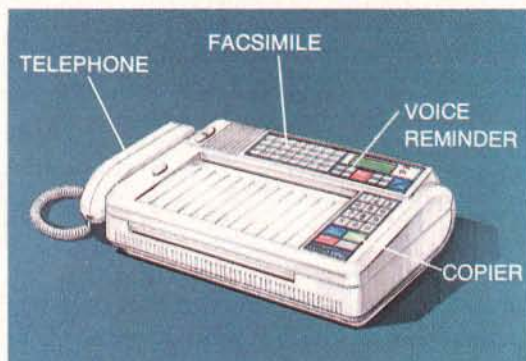

US\$1,195

4 functions in 1 unit

You surely have a dream to hold every single message around the world to catch up with this high-tech era. In order to get closer to your friends, clients, and lover, you must own her—GUI Personal Fax:

She never strikes, never stops.
She never sleeps, never spys.

She performs as:

CCITT G3/G2, 9600 bps; Auto Fallback
Hand free speed dialing for easily sending
Auto redial for efficiency increasing
32 one-touch dialing for friendly using
Auto power off for cost saving
Normal/Fine mode for best quality
Text/Half-tone to secure the colorful result
LCD for clear display of all essential information.

She is your secretary to auto answer your incoming fax and telephone call.

She is a recorder to record messages, when you are away.

She is a voice-reminder to leave message to your partners and colleagues.

And she is so fantastic, considerate and lovely that you can't miss her.

GUIS

A Little Giant in Telecommunications

Distributor wanted

Glorious Union Information Systems Inc.

14th Fl., 207 Tun-Hwa N. Rd., Taipei, Taiwan, R.O.C.

TEL: 2-7171740, 2-7153356 TLX: 22651 GUI5

FAX: 2-7134572

LT3200



High Speed High Performance Laptop

80286 6/12MHz Clock

1.44 MB 3 1/2" Floppy Drive

40 MB Hard disk

640x400 high resolution Plasma Display

 **COMDEX/Fall '88**

Booth No: R8028, 8231

R8030, 8229



PAOKU P&C CO., LTD.
P&C SHITEN ENTERPRISE CO., LTD.

HEAD OFFICE:
12F-10 NO. 100, ROOSEVELT RD., SEC. 3,
TAIPEI, TAIWAN, R. O. C.
EXPORTER: PAOKU P&C CO., LTD.

TEL: (02) 395-1400
TELEX: 19206 PCSHITEN
FAX: 886-2-3512073
P. O. BOX: 30-291 TAIPEI

FACTORY: P&C SHITEN ENTERPRISE CO., LTD.

CSC COMPUTER SYSTEMS CORP.

240 JAMES ST. BENSenville, IL 60106
TEL: (312) 766-5770 FAX: (312) 766-5812

Circle 413 on Reader Service Card

New Release!

UNIQUE DESIGN — MODEL 5000X CABINET

* **SMALL & SLIM** — 37.5Wx11.5Hx42.0D CM

Front Panel — Only 9 CM high

* Can fit **XT.286.386 & PS-II** MOTHERBOARD

Also incl. 6 horizontal slots.

* **DRIVE SPACE** — 4 drives can be fitted, including
2 types of drives 5-1/4" & 3-1/2"

OPERATING PANNEL — Triangle-Solid
& Inclined-plane

* **SCREEN WINDOW** — show speed,
time & 3 lamps for power, turbo,
HDD, ctl. by 4 buttons. **See us at:**

 **COMDEX/Fall '88**

Las Vegas
November 14-18
Booth: C928

ALL-IN-ONE —

Mother Board: 5000X

CPU: 80286

Speed: 6/12/16 MHz

Video: VEGA,

MCGA compatible

I/O Port: 2 SER/1 PAR.

Memory: 512KB to 4MB

and 3 MODES EMS.

FDD CTRL: 360K to 1.44MB

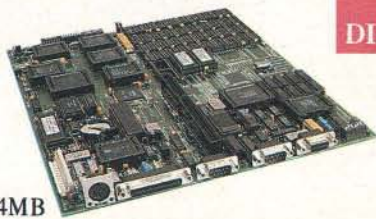

CABINET & MAINBOARD INQUIRIES WELCOMED!

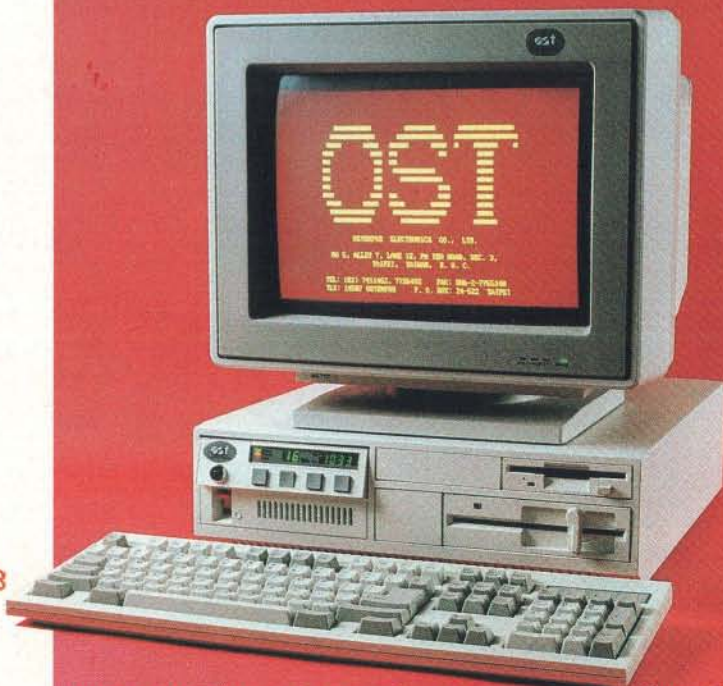

DISTRIBUTORS & DEALERS WELCOME

Model 5000X (80286)
Model 8000X (80386)



OSTEMPOR INTERNATIONAL INC

No. 5, Alley 7, Lane 12,

Sec. 3, Pa Teh Road,

Taipei, Taiwan, R.O.C.

Tel: (02) 741-1462

FAX: 886-2-7765140

TLX: 14507 OSTEMPOR

U.S.A. Service Center:

8820 28th S. W. Seattle

WA 98126 U.S.A.

Tel: (206) 878-1683

Fax: (206) 824-9847

Manufacturer

THE WAY TO BE IN TOUCH

DATA COMMUNICATIONS BY MAXAN

Maxan specializes in the design and manufacture of data communications products including a complete line of 2400 bps modems, ethernet LAN products and PC fax cards. If you're a distributor searching for satisfaction, contact Maxan. Suite 401, No. 333, Fu Hsing N. Rd., Taipei, Taiwan, R.O.C. FAX: 886-2-717-2401 TLX: 10619 MAXANIND



Circle 411 on Reader Service Card

We invite you to visit us at this year's fall Comdex show at booth R8024.

WE OFFER NOT ONLY A FAX CARD BUT A COMMUNICATION SOLUTION

WHAT YOU GET IS WHAT YOU WANT !

DIGIFAX CWS-186F

- *IMAGE COMMUNICATION COMMUNICATE WITH 2 MILLION OF FAX MACHINES AROUND THE WORLD
- *DATA COMMUNICATION ANY TYPE OF FILE TRANSFER. 10,000 WORDS ONLY TAKE 10 SECONDS
- *WORD PROCESSOR SCREEN EDIT, SAVE, LOAD, DEL, DIR, ETC.
- *GRAPHIC FUNCTION VIEW, CUT, MERGE, TEXT ADD, ERASER
- *BROADCAST IMMEDIATE SCHEDULING MULTI-FILE & MULTI-ADDRESS TRANSMISSION

- *TIME DELAY SEND
- *PC AUTOMATIC POWER ON/OFF
- *PHONE BOOKS 20 PHONES BOOKS STORE 16,000 CUSTOMER'S INFORMATION & TRANSMITTED BY BROADCAST MODE
- *FILE CONVERT ASCII, WORDSTAR, DR, HALO, PAINTBRUSH, GEM.
- *AUTO CONVERSION FROM TEXT TO IMAGE WHEN TRANSMITTING
- *SCANNER SUPPORT HANDY SCANNER & CANON IX BIX 12. MICROTEK DESK-TOP SCANNER

- *PRINTER SUPPORT DOT MATRIX, LASER (HP), INKJET PRINTER
- *FUNCTION CALL SUPPORT
- *MODEM SOFTWARE SUPPORT

DIGISCAN DS-105

- *SCANNING WIDTH 105 MM(4 INCH)
- *GRAY SCALS B/W AND 16 QUASI-TONES
- *SOFTWARE DIGIFAX, DR, HALO DPE
- *RESOLUTION 200 DPI(8 DOTS/1MM)

DIGI-AUTON

Circle 403 on Reader Service Card



Welcome to See Us At:

COMDEX/Fall '88
NOVEMBER 14-18
RIVIERA, BOOTH:R8215

For more information, please contact us:



DIGITECH COMPUTER CO., LTD.

3FL. NO.2, HSIN SHENG S. RD., SEC.2, TAIPEI, 10618, TAIWAN P. R. TEL. 886-2-3217001 FAX. 886-2-3944680 TLX. 24866 DIGITECH

GOOD WAY

Quality & Guarantee of Computer & DATACOM Accessories
We will offer.



NET-TALK KITS



SBS1 TERMINATOR



APP-NET

GD-095 S.C.S. I Terminator
GD-093 APP-NET (PHONE-NET Compatible)
GD-096 NET-TALK KITS (APPLE Local Talk Compatible Kits)
Also, We offer full range of computer cable and data switch.

GOOD WAY INDUSTRIAL CO., LTD.

OFFICE:
P.O. BOX 91-202 TAIPEI
TEL: (02)5017197-8, 5055285
CABLE: SUWORS TAIPEI
TELEX: 12445 SUWORS
FAX: 886-2-5056377

FACTORY:
NO. 14-1 DAH HER LANE 2
SHI TWEN DISTRICT
TAICHUNG, TAIWAN
TEL: (04)2551192-3 + 2551220

98.9% Radiation and 100% Static Free Working Environment

Patents: U.S.A., R.O.C.
Patents pending: EEC, Japan, Korea.
See us at



COMDEX/Fall '88

November 14-18, 1988
Bally's Las Vegas
Las Vegas, Nevada
Booth: B519

RCS 581 VDT Filter

*98.9% radiation and 100% static free level.

*Eliminates glare and reflection.

RCS 582 Anti-Static Computer Cover

*Made of conductive fibers prevents charge collection and provides full static shield.

*Prolongs the computer's life two times.

RCS 583 Anti-Static Keyboard Str.

*Made of highly conductive fibers.

*Includes a 3-meter grounding cord.

*Doubles computer's lifespan.

RCS 587 Anti-Radiation Operator Apron

RCS 588 Anti-Static Car Seat Cover

RCS 590 Anti-Static Fabric

RCS 593 Anti-Static Steering Wheel Cover



RCS-581



RCS-583

Distributor Welcome



RCS TECHNOLOGY CORPORATION

12F., No. 148, Sung Chiang Rd., Taipei, Taiwan, R.O.C.
Tel: 886-2-5512614 (Rep)
Telex 28902 RCSTEC Fax: 886-2-5363696

The Best Peripherals For PS/2



MEC-1
Memory
Expansion
Card

*2Mb on board

EFDD-2 5.25" External FDD

*Read/write, format both 360kb and 1.2mb diskette

*No expansion slots, interface card and power supply required

*For entire PS/2 family

LM-2 Mouse

*High tracking speed 1048mm/sec

*Alps Micro-switch, two-button, DIN connector

*Resolution: 200 DPI

*Fully compatible with IBM and Microsoft PS/2 Mouse

*Reserve sockets for 1M x 1 OR 44256 RAM

*For Model 50/60

See us at Comdex Fall

COMDEX/Fall '88

Booth S9118



LABWAY COMPUTER CO., LTD.

2F, NO. 74, NANKING E. RD. SEC. 5
TAIPEI, TAIWAN, R.O.C.
TEL: (02)7620980 (REP) FAX: 886-2-7692971

IBM, PS/2, Microsoft are registered trademarks of their owners

ROYAL TREATMENT FOR DATA IMAGING Interface a Hi-Res TRL Monitor



14" MONOCHROME MONITORS

- T-1418 Single
- T-1428 Dual
- T-1429 29KHz
- T-1438 Multisync
- T-1448 VGA



14" COLOR MONITORS

- CT-1456 EGA
- CT-1458 Multisync
- CT-1468 VGA

19" MONO MULTISYNC MONITORS

- CT-1918 1024x768
- CT-1928 1280x1024

19" COLOR MULTISYNC MONITORS

- CT-1958 1024x768
- CT-1968 1280x1024



ROYAL INFORMATION ELECTRONICS CO., LTD.

7F-1, No. 63, Sec. 2, Chang An E. Rd., Taipei, Taiwan, R.O.C.
Tel: 2-5065646 Fax: 2-5065626 Telex: 27974 ROYALL

Datacomp's New Surprising Release



DFK-171 (101 keys,
Membrane type)

- * Plug compatible with IBM PC/XT/AT & PS/2
- * Meets DIN low profile standards
- * More compact design
- * M-key rollover & auto-repeat
- * Nonerasable printing performance on key caps by using new Sublimation technology.
- * Completely water, dust-proof.
- * Adjustable angle feet ensure proper tilt from 7 to 14.5 degree.

DFK-555 105-keys for Macintosh is available

IBM PC/XT/AT PS/2, Macintosh are registered trademarks of their owners



COMDEX/Fall '88
The RIVIERA Hotel.
Booth No.: R8233

DATACOMP ELECTRONICS CO., LTD.

3F-2 NO.598 MING-SHENG E. ROAD. TAIPEI TAIWAN R.O.C.
TEL: 886-02-7152441~2 FAX: 886-02-7129369 TLX: 13975 DATACOMP

The New Fashion for PCs



Make PC Perfect Godspeed Series:

1. Computer Cabinet
 2. Switching Power Supply
 3. Keyboard
- Manufacture & Export



GS-50A

GS-27X 150W
GS-27B 200W
for GS-35S

GS-26B 200W
for GS-16B

Power
Supply



For 80386, 80286
or Baby AT
SIZE: 1480 x 165 x 595mm

GS-35S SIZE (390 x 410 x 90mm)



GS-35S (white), GS-36S (black) Slim Case

- * 1.4 mm thickness, plus one slot card
 - * Drives: two 3.5" FDs and one hidden HD
 - * Suitable for 8088, Baby AT main boards
 - * Dimensions: 390 x 410 x 90mm
- GS-16B Baby AT/XT Case
- * 1.4 mm thickness
 - * Two metal supports for a strong structure
 - * Drives: three 5.25" FDs, two 3.5" FDs or HD
 - * Suitable for 8088, Baby AT main boards
 - * Dimensions: 435 x 420 x 158mm



Lap-Top Case

Godspeed Computer Corp.

P.O. Box 7-82, Taipei, Taiwan, R.O.C.
3F, No. 177-2, Heping E. Rd., Sec. 1, Taipei, Taiwan, R.O.C.
Telex: 15306 GOOD COMP
Fax: 886-2-3921389
Tel: (02) 392-1367, 321-5498, 397-3213

ADD-ON CARD LINES:

- RTX-01A IEEE-488 (XT/AT-compatible)
- RTX-02A 8255 I/O Card (XT/AT-compatible)
- RTX-02B 8255 Plus Card (XT/AT-compatible)
- RTX-03A 12-Bit A/D-D/A Card (XT/AT-compatible)
- RTX-11E Copy Card (XT/AT-compatible)
- RTX-15B EPROM Writer Card (XT/AT-compatible)
- RTX-22B Fax Card with Power Center (XT/AT/386/PS2 Model 30-compatible)
- RTX-23A 4.77MHz XT Mainboard
- RTA-03B Dual Serial/Parallel/Card
- RTA-03C 4-Port Multi-user Card (Xenix & AT/386-compatible)
- RTA-03E 4-Port Multi RS-422 Card (Xenix & AT/386-compatible)
- RTA-3F Dual Serial/Parallel/Game Card
- RTA-04A Neat 286 Mainboard
- RTA-05A FDD/HDD Card (W.D. chips)
- AT & 386 RAM Card in 1MB, 2.5MB, 3MB, 35MB, and 4MB increments
- AT & 386 2MB EMS RAM Card
- AT Multifunction Card in 2.5MB, 3MB, and 35MB capacities

RTX-02B 8255 Plus Card

- * 96 programmable I/O control lines
- * 2 sets of 3 independent 16-bit counters
- * 2 programmable interrupt chips



RTA-03E Multi RS-422 Xenix Card

- * Runs with IBM PC AT/386 and compatibles
- * Compatible with IBM, Microsoft, and SCO Xenix software
- * 4-port asynchronous EIA RS-422 interface
- * 3,000-ft maximum range compared to 300-ft radius RS-232 card
- * IRQ2-IRQ7 selectable multiplex modes
- * 2-channel software compatibility with COM1 and COM2 programs

RTX-22B Fax Card with Power Center

- * Host compatibility: IBM PC/XT/AT and PS/2 Model 30
- * Fax compatibility: CCITT V.29 and V.27 TER, T4, T30
- * Interfaces for: scanner, mouse, light pen
- * Transmission speed: 9600/7200/4800/2400 bps Auto Select
- * File transfer: 9600/7200/4800/2400 bps Modem Functions
- * Data format: synchronous
- * Auto ON/OFF power feature via incoming ring or PC keyboard
- * FCC-approved



**Real Time
Industrial Co., Ltd.**



REAL TIME INDUSTRIAL CO., LTD.

P.O. Box 93-61, Taipei, Taiwan, R.O.C.
Tel: 16425 REALTIME Fax: 886-2-7352069 Tel: (02) 7320847, 7352086

Key-Mouse

Plug into keyboard directly,
Without other interface.

Real Two-Steps
Tactile

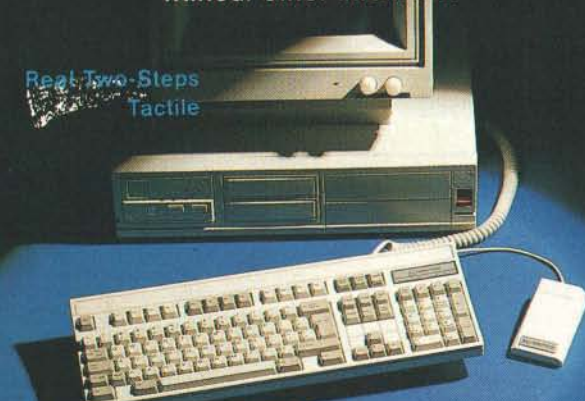

Hontron's Product Family Includes:

- Membrane-type Keyboard:
 - * For IBM PC/XT/AT & PS/2 Model 30, 50, 60, 80 and compatibles.
 - * Having 2-step tactile feeling.
 - * Mini size: 450 x 160 x 25
 - * Weight: 0.95Kg
- Key-Mouse
 - * Fully compatible with IBM PC/XT/AT & PS/2 mouse and Microsoft PS/2 mouse.
- Terminal keyboards (122-key, 105-key)

OEMs Welcome

COMDEX/Fall '88
November 14-18, 1988

Riviera Hotel • Booth No: R8525



Professional Keyboard Manufacturer & Exporter

HONTRON CORPORATION

Address: 6F, 3, Lane 166, Wen-Lin N Rd., Taipei,
Taiwan, R.O.C. Tel: (02) 8360665 • 8342575
Fax: 886-2-8350665 Telex: 12951 HOUSOUND

BYTE's Subscriber Benefits Program

Your BYTE subscription brings you a complete menu of the latest in microcomputer technology every 30 days. The kind of broad-based objective coverage you read in every issue. *In addition*, your subscription carries a wealth of other benefits. Check the check list:

BONUSES

✓ **Annual Separate Issues:** In addition to BYTE's 12 monthly issues, subscribers also receive our annual IBM PC issue free of charge, as well as any other annual issues BYTE may produce.

✓ **BYTE Deck:** Subscribers receive five BYTE postcard deck mailings each year—a direct response system for you to obtain information on advertised products through return mail.

✓ **Reader Service:** For information on products advertised in BYTE, circle the numbers on the Reader Service card enclosed in each issue that correspond to the numbers for the advertisers you select. Drop the post-paid card in the mail and we'll get your inquiries to the advertisers.

✓ **TIPS:** BYTE's Telephone Inquiry System is available to subscribers who need *fast response* from advertisers. After obtaining your Subscriber I.D. Card, dial TIPS and enter your inquiries. You'll save as much as ten days over the response to Reader Service cards.

✓ **Free Programs Via BYTENet:** You get access to the BYTENet Bulletin Board Service, which allows you to download, via



modem, valuable program listings. There is no connect charge for this service.

✓ **Subscription Service:** If you have a problem with, or a question about your subscription, you may call our service department toll-free at 800-423-8272 (in New Jersey call 800-367-0218) during regular business hours (Eastern Time). You can also use Subscription Service to obtain back issues. Should you care to correspond, use the following address: P.O. Box 6821, Piscataway, N.J. 08855.

✓ **Editorial Indices:** Available through our customer service department P.O. Box 328, Hancock, New Hampshire 03449.

PAID SERVICES

✓ **BIX:** BYTE's Information Exchange puts you on-line 24 hours a day with your peers via computer conferencing and electronic mail. All you need to

sign up is a microcomputer, a modem, and telecomm software. For further information and cost, call 1-800-227-BYTE.

✓ **Program Listings:** Listings of programs that accompany BYTE articles are now available on BIX, on disks or in quarterly printed supplements (see reply cards in this issue for cost information), or call 1-800-258-5485.

✓ **Microform:** BYTE is available in microform from University Microfilm International in the U.S. and Europe. See Contents page for cost information.

DISCOUNTS

- ✓ One-year subscription at \$22.95
- ✓ Two-year subscription at \$39.95
- ✓ Three-year subscription at \$55.95
- ✓ One-year group subscription for ten or more at \$18.95 each. (Call or write for details.)

TOLL-FREE NUMBERS FOR YOUR CONVENIENCE:

Subscriptions & Back Issues:

1-800-423-8272
(in N.J., 1-800-367-0218)

BIX: 1-800-227-BYTE

Program Listings Orders:
1-800-258-5485

BYTE



It's indispensable.

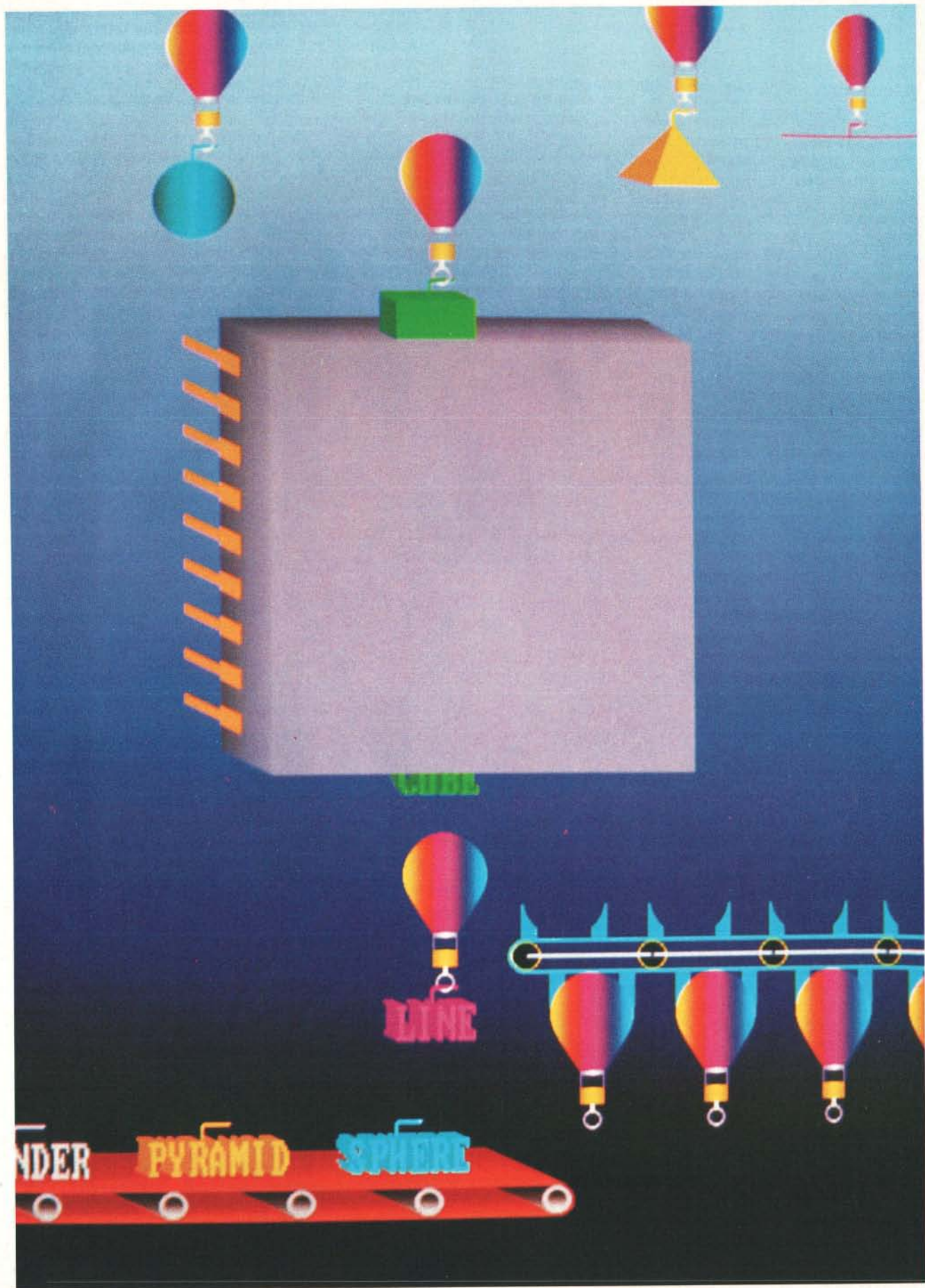

REKURSIV: AN OBJECT-ORIENTED CPU

The Linn Rekursiv is a new microprocessor designed to run object-oriented languages

Dick Pountain

Linn Products, a hi-fi firm based in the electronics manufacturing belt that surrounds Glasgow, Scotland, has a worldwide reputation in the audio marketplace. In the early 1970s, Linn was one of the first firms to spot the market for uncompromising audiophile sound equipment, and the Linn Sondek is still regarded by its many fans as the finest record turntable ever made.

A Linn subsidiary, Linn Smart Computing, recently announced the Rekursiv, an innovative new computer architecture designed around principles of object-oriented programming. How Linn came to design a new microprocessor is an interesting story in itself.

Something Better

Linn's founder, Ivor Tiefenbrun, is a strong believer in computerization, which, until now, the firm had implemented with a series of minicomputers. Starting with PDP-11s in the 1970s, Linn now employs two DEC VAX-11/750s, two 11/780s, and a host of assorted micros. These machines are used for accounting, stock control, word processing, and the other typical business-administration tasks, together with a limited amount of production control over the cranes and conveyor belts. As a man noted both for technophilia and iconoclasm, Tiefenbrun soon became deeply dissatisfied with the software available for these machines and, in particular, with the lack of functional integration and ability to be modified.

By the early 1980s, Tiefenbrun's surveys of current computer research trends had convinced him that an object-oriented programming system would allow Linn to integrate all the factory's functions with flexibility. Since few, if any, such systems were commercially available, and since Glasgow is surrounded by some of Britain's finest university computer science departments, Tiefenbrun decided to have such a system designed.

In 1981, programmers and a compiler writer were hired, a Glasgow computer science lecturer was taken on as a consultant, and a language system called LINGO, with many of the

features of Smalltalk, was written. However, the performance of LINGO on the VAX proved to be far from adequate for the task of automating a whole factory. Instead of giving up or going in for a long cycle of software optimization, Tiefenbrun characteristically decided to finance the development of a new processor architecture optimized to run object-oriented languages orders of magnitude faster than conventional hardware can. Thus was born the Rekursiv project. (Tiefenbrun seems to be inordinately fond of the letter *K*; Linn has hi-fi products called Sondek, Basik, Ittok, and Asak.)

In 1984, Linn Smart Computing Ltd. was set up and Dr. David Harland joined as technical director, a job he combines with being visiting professor of computer architectures at the University of Strathclyde. He and his team have designed a chip set with which to implement a persistent-store, object-oriented processor.

Object-Oriented Programming

An object-oriented programming system is one where programs are executed by sending messages to packages of data called objects. Each type or class of object has a set of operations that may be performed on its members, and you can apply these operations only by sending a message. The internal structure of an object is hidden from the programmer, who must manipulate it only with the allowed operations.

This type of system provides a high degree of security and modularity as application programs are isolated from the implementation details of the objects and their operations. Program modifications are very localized and, hence, easy to perform and more likely to be correct. The best known example of such a system is Smalltalk-80 (see "Smalltalk/V Release 1.2" by Mat Davis, June 1987 BYTE, and the section on object-oriented languages in the August 1986 BYTE).

An added attraction of the object-oriented style of programming is that you can make program objects correspond to objects in the real world in a more concrete way than do the vari-

continued

ables and procedures of a conventional programming language like C or Pascal. The data contained in an object can represent its attributes (e.g., size, color, and age) while the allowed operations represent its behavior. You can alter the program's behavior by sending it messages. Object-oriented languages are a natural for writing simulations of all kinds.

A very prominent property of real-world objects is that they

I *magine*
a world where people are flown
to the moon to sleep every night
and then flown back
the next morning to work;
that's how incongruous
explicit I/O is in an object-oriented
program universe.

persist; that is, they tend not to disappear without good reason (with odd exceptions like car keys and left socks). In most computer systems this is not the case. When you switch off the power, everything contained in the computer's RAM disappears. Program variables are more volatile still. They will disappear when you terminate the program to run another one, or even (in the case of local variables) when a procedure within the program terminates.

The only way to preserve information from one session to another is to write it onto a permanent storage device of some sort, usually a floppy disk. However, the information always has to be translated into a different format to be stored, and the actual acts of storage and retrieval involve special I/O operations. These functions are invariably complicated and have different semantics from storage operations within a program such as assignment to a variable.

Persistent programming is a research avenue being explored at several universities, including Glasgow. In a persistent programming environment, the concept of I/O is abandoned altogether, and the values of program entities are preserved from one invocation of a program to the next until you explicitly deallocate them. There is no distinction between long-term data and short-term data, and the same operations are used for both. No separate filing system is needed, since ordinary program entities such as arrays and lists can serve for long-term storage.

In terms of implementation, though, you need to underlie the persistence with some kind of disk-based virtual memory that is automatic and transparent to the programmer. In a normal programming environment, to store the value of a variable on disk, you would have to create a file, open it, copy the value of the variable into the file, close the file, and so on. In a persistent programming environment, variable values still get written to disk, but you won't know when, you don't need to explicitly request them, and the format of the data doesn't need to be explicitly altered to do so.

Persistence and object orientation are natural partners, because if your program is a simulation built from objects, then you might expect these objects to live for as long as their real-world counterparts. Imagine a world where people are flown to the moon to sleep every night and then flown back the next morning to work; that's how incongruous explicit I/O is in an object-oriented program universe.

The sort of data-processing system Linn hopes to build is one where every object in the factory has an equivalent object in the computer system. When workers build a product, say a turntable, the product gets allocated its own object. This object simulates the product, reflecting its progress through the production process. The object accumulates information as the product goes through testing and quality control, even to after-sales, where the object can contain the service records. The Rekursiv processor is designed to support this model of computing in hardware.

The Rekursiv Architecture

To say that the Rekursiv departs from the mainstream of current processor design would be a gross understatement. Reduced-instruction-set-computer technology has become the new orthodoxy in high-performance processor design, and Rekursiv is not a RISC. Instead, it supports microcodable, ultra-high-level instruction sets and could be better described as a WISC (writable-instruction-set computer; see "The WISC Concept" by Phil Koopman, April 1987 BYTE).

Professor Harland's prime concern is with bridging the "semantic gap" between the operations required in a high-level language to simulate real-world activities, and the operations that a digital computer can handle. RISC designs actually increase the semantic gap (by having only simple instructions) for the sake of higher throughput, the idea being that you employ the extra performance to close the gap in software.

Rekursiv takes the opposite tack and allows you to design very high-level instructions. The very name *Rekursiv* suggests that machine instructions can be made arbitrarily complex, including recursive calls and even calls to other programs; for example, a tree-walking routine can be microcoded as a single instruction.

The Rekursiv achieves high performance by having multiple internal memory buses so that many operations can occur in parallel, instead of a highly optimized serial instruction pipeline like a RISC. Built from three custom gate arrays and several megabytes of fast static RAM, the Rekursiv is a single-board rather than a single-chip microprocessor (see photo 1).

This SRAM holds the microcode and the pager tables used to keep track of objects; it exists inside the processor like a conventional processor's register set. The SRAM is organized into six different functional memory spaces, each with its own data and address buses, a side effect being that the gate arrays require the largest packages ever: 299 pins to handle all the lines. Since there is also a dynamic RAM (DRAM) interface for the main object store memory, the Rekursiv could be labeled a seven-memory architecture. Even this is an underestimate since the pager tables employ separate buses for each field.

Figure 1 shows a block diagram of the main functional units of Rekursiv, where the three gate arrays are the blocks called Objekt, Numerik, and Logik. The six blocks that are implemented in SRAM are the two stacks (control and evaluation), control store and control store map, the pager tables, and the block marked NAM (more on NAM later). Most of Rekursiv's internal data paths are 40 bits wide, though the DRAM address bus is only 24 bits wide. Objects are stored both in DRAM and

continued



While dBASE Promises You The Moon, Clipper Delivers.

Right now, while others dream about the database of the future, you can be using it today to create applications of unparalleled sophistication. With Clipper® — the most powerful and complete database development system for PCs.

Open the Clipper box and you'll find the enhancements dBASE® has been promising. And some it hasn't.

Such as: a remarkable development language that takes you way beyond dBASE® emulation, with enhanced commands and entirely new language extensions. A unique open architecture which gives you the flexibility to create and easily integrate user-defined functions in C, Assembler, Clipper, and still other languages. The speediest-ever dBASE compiler, yielding applications up to 20 times faster. And that's just for starters.

Clipper also provides the most capable menu-driven debugger to be found anywhere, as well as half a dozen modifiable utilities to further reduce development time.

There's source code security, too, plus sophisticated record and file-locking capabilities that make networking

	Clipper® \$695*	dBASE III. PLUS™ \$695*	dBASE IV™ Developers Ed. \$1295*
A true compiler	Yes (1984)	No	???
User-defined functions	Yes (1984)	No	Promised
Arrays	Yes (1985)	No	Promised
VALID function	Yes (1985)	No	Promised
Improved Execution Speed	Yes (1984)	No	Promised
Link in Other Languages	Yes (1984)	No	Promised
Null Character Support	Yes (1987)	No	No

*Suggested retail price

applications easier to create.

And once you have created them, Clipper gives you an equal measure of control over distribution by creating .EXE files — there are no runtime modules, licensing or royalty fees, or additional software requirements. You can even add stations to a network without adding to your costs.

All of which adds up to the most powerful and flexible database

development system today.

Why settle for the moon when you can reach for the stars? Call (213) 390-7923 today, and we'll send you a free demo diskette and a very informative booklet, *Developing and Compiling in Clipper*. The dBASE development system that's not just one small step...but a giant leap forward in programming power.

Clipper®

Nantucket Corp., 12555 W. Jefferson Blvd., Los Angeles, CA 90066
Telex: 650-2574125 Fax: 213-397-5469

Copyright © Nantucket Corporation, 1988. All rights reserved.
Nantucket and Clipper are registered trademarks of Nantucket Corporation. dBASE is a registered trademark and dBASE III PLUS and dBASE IV are trademarks of Ashton-Tate Corporation.

BUGS

Search & Destroy

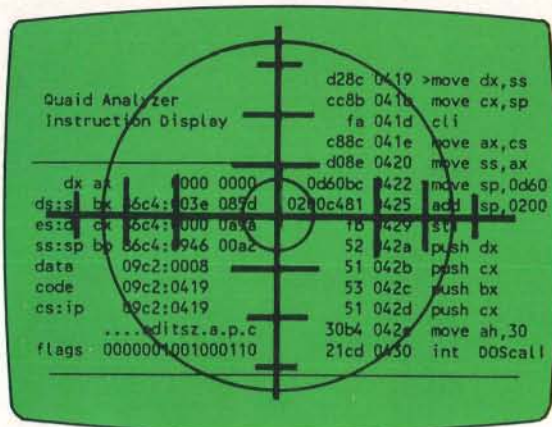

Quaid Analyzer is the ultimate diagnostic tool for the expert programmer.

With Quaid Analyzer you can trace any software without source code; monitor any interrupt; scroll through memory; debug code written in any language; easily change values in memory, registers and at i/o ports. And you never need to type a command!

Now you can have the same powerful tool used to develop CopyWrite. Quaid Analyzer. If you need to search and destroy bugs – fast.

To order **Quaid Analyzer**, call us with your credit card, or send us a check for \$200 US funds. We ship within a day at our expense.

QUAID Analyzer

OR YOU'LL NEVER KNOW WHAT YOU'RE MISSING.



Quaid Software Limited
Third Floor, Dept. B641
45 Charles St. E.
Toronto, Ontario
Canada M4Y 1S2.
(416) 961-8243.

on hard disk, in what could be thought of as equivalent to the external memory of a conventional processor, but since the microcode can access this memory, too, the distinction between inside and outside is blurred.

The Rekursiv's sole purpose in life is to create objects, to page them back and forth between memory and hard disk, and to perform arithmetical and logical operations on the data in their fields. You can think of it as combining the functions of a CPU, memory manager, database manager, and operating system all in one. An object is just a chunk of memory divided into fields that hold its data and represent the *instance variables*, in

continued

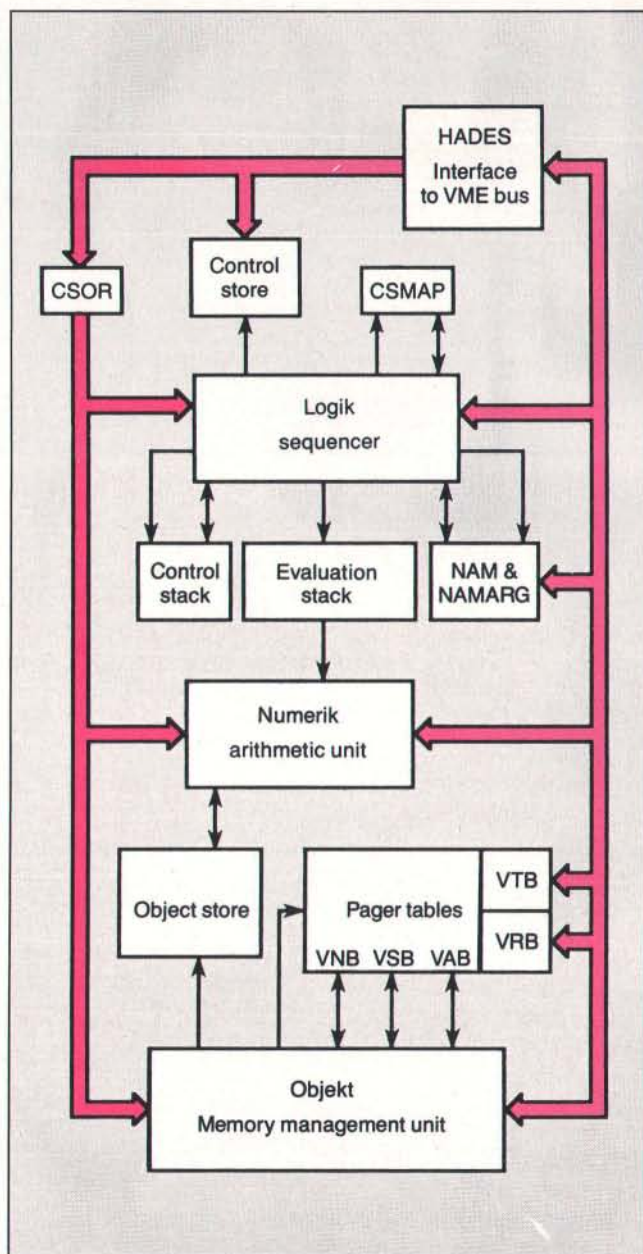

Figure 1: A block diagram of the main functional units of *Rekursiv*, a persistent-store, object-oriented processor that, in effect, combines the functions of a CPU, memory manager, database manager, and operating system all in one.

Receive a

FREE* SIVA 386 SYSTEM

with the purchase of \$2995++
of software or \$4995++ of
hardware.

Standard 386 Features:

- 32-bit Intel 80386-16 CPU.
- 1MB of 32-bit RAM on board. System expandable to 16MB.
- 8/16/20 MHz Keyboard selectable.
- ST-251-1 Seagate 40MB Formatted 28 ms high speed, with ultra high speed Controller 1:1 interleave.
- 1.2MB High Capacity Floppy Drive.
- Super deluxe heavy duty tower case with 6 half-height drive openings.
- High-resolution 12" Non-Glare Amber Display. Tilt and Swivel base, Hercules-compatible Adapter.
- 101 Key Enhanced Keyboard, Pleasant "Tactile/Click" Feel.
- 80287/387 Math-Coprocessors optional.
- Fully compatible with virtually all XT/AT and 386 software.

Upgrades for your FREE 386 System:

- VGA Color Upgrade — add only \$495.
- 20 MHz CPU Upgrade — add only \$195.
- Call for all other options and upgrades.

Choose Your Hardware

A hardware purchase of \$4995 or more is required
to receive the SIVA 386 System FREE.

- | | |
|--|--------|
| • QMS PS 800II Postscript Laser Printer | \$5995 |
| • QMS PS 810 Postscript Laser Printer | \$4995 |
| • CDC WREN IV 300MB SCSI
Hard drive with Controller | \$2595 |
| • CDC WREN III 155MB SCSI
Hard drive with Controller | \$1795 |
| • CDC WREN II 86MB ST506
Hard drive with HD/FD Controller | \$ 895 |
| • Eight Port RS232 Intelligent Card
with Xenix Driver | \$ 995 |
| • 32-Bit 8MB Memory Expansion Board | \$2997 |
| • Intel 80387 — 16 Coprocessor | \$ 495 |

Software

- | | |
|---|--------|
| • Complete SCO Xenix System
(including Operating System, Developing System and
Text Processing System for 80386-based System) | \$1595 |
| • SCO Lyrinx System | \$ 595 |
| • SCO Professional | \$ 895 |
| • SCO Integra | \$1295 |
| • SCO Foxbase Plus | \$ 995 |
| • SCO VP/IX
(integrated DOS environment — two users) | \$ 495 |
| • Language & Development Tools | CALL |
| • Networking & Communication Packages | CALL |

A software purchase of \$2995 or more is required to receive
your FREE SIVA 386 System. Mix and match to meet
your needs!

Prices are for Industry Standard 80386-based Computers.
For all other systems and items please call:

1-800-252-4212

VNS America Corp.

Suite 270, 910 Boston Post Road
Marlboro, Massachusetts 01752 U.S.A.
In Massachusetts 508-460-0016
FAX: 508-481-2218

*Offer good until December 31, 1988.

Circle 354 on Reader Service Card

Smalltalk parlance. Every Recursiv object is identified by a unique 40-bit number that is assigned to it at its creation (from a counter called the allocator) and that remains with it for its life. This number is the only way you can refer to the object, because only the processor knows its real address.

When they are stored on disk, objects are prefixed by a header holding the object's number, size, and type (a 40-bit value that the software must interpret in some meaningful way). Types are objects, too, so the type field contains a 40-bit object number. When an object is transferred into memory, only the data fields are written into object store; the header is stripped off and written to a slot in the pager table along with the new address of the data in main memory. The pager table contains 65,536 (i.e., 64K) slots that you can address very quickly by hashing on the object number.

If the pager table slot for a requested object is occupied, then the object's address is retrieved from the slot along with the offsets to index its fields, and the requested operation is performed on its data. During this table lookup, the hardware also checks the type field, refuses to perform operations that are not allowed on the type, and performs range checks so you can't index a field that lies outside the object.

If the slot for the requested object is empty, that means it is not currently in main memory and there is a page fault. The Rekursiv is stopped dead while a signal is sent to an external disk processor to fetch the object into memory.

This disk processor has its own B-tree directory structure, which allows it to find an object's image on disk through its number. When the object has been fetched to memory and its

header put in the pager table, the Rekursiv resumes processing as if nothing had happened, without any need to restart the current instruction, as there would be with a conventional processor. Page fault recovery occurs "below" the level of instruction execution, rather than being an external operating-system task. It is this property that enables Rekursiv's microcoded instructions to be of arbitrary complexity and to include recursive calls that are forbidden to normal CPUs.

The programmer's view of Rekursiv is of a truly object-oriented processor in which there is no concept of an address, only of object numbers, and where objects persist until you destroy them. Programs can be executed only by requesting an operation on a numbered object. In a network of workstations, the object universe can be extended to cover the whole network, and object numbers can be made to indicate in which processor an object was born.

Memory Management

Memory management, especially garbage collection, has always been a problem for object-oriented systems. In the real world, dead objects get eaten by crows or bacteria or consumed by rust or whatever, but in a computer simulation, they just hang around and clog up the all-too-finite memory space.

Rekursiv has been designed with a brutal, but fast, garbage-collection strategy. The DRAM object store memory is divided into halves, only one of which is used at any time. The last address in this active half is called EndMem, and the "grabspace" operation that creates new objects contains a hardware test that stops it from allocating object addresses that would exceed

If our Flexible New DigiChannel/Xi Intelligent Multi-Channel Communications Board doesn't fit your application, read our ad on the right.

See us at
UNIX EXPO
and
COMDEX FALL

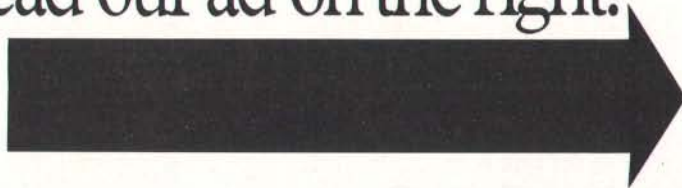

Several years ago, we introduced a state-of-the-art intelligent multi-channel communications board. It was 400% faster than basic boards and set new standards for programmability, flexibility and reliability.

Now, with the new DigiCHANNEL/Xi, we've advanced the state-of-the-art again. A 16 MHz 80186 co-processor makes it twice as fast. And plug-in I/O Mate modules make it even more flexible. So does its full

range of drivers, and optional 512K of RAM and 128K of ROM. Plus, a synchronous channel opens a new range of communications options.

In other words, if your multi-user or multi-channel applications call for the last word in speed, configuration flexibility and programmability, call us about the new DigiCHANNEL/Xi.

If not, read our ad on the right.

DigiBoard
Plugging you into tomorrow.

Call 1-800-344-4273. In Minnesota, (612) 922-8055.

EndMem. When this test fails, more memory is required and the Objekt chip invokes hardware garbage collection.

The Objekt chip initiates a tree-search of all the object dependencies in the processor, taking in both the stacks and a handful of registers. The chip then inspects each object by paging it with disk fetches disabled, and it tags those that do not exist on disk—these must be objects that are either newly created, or old but modified (i.e., they have been read from disk, altered, and not yet written back). Then it undertakes a linear scan of the pager table, copies only the tagged objects into contiguous addresses in the other half of DRAM, updates the pager tables, and resumes execution in the new memory space. In effect, this is a heap compaction performed in hardware.

This hardware compaction is low-level and completely transparent, dealing as it does with physical rather than logical memory. Its speed is largely independent of the content of the memory or its degree of fragmentation. As with page faults, the processor is unaware of its occurrence and can resume execution where it left off.

If this process still does not free enough memory, a second level of garbage collection progressively squeezes out other objects to disk to free up space. If even this fails (i.e., a new object wants all the memory), then a last resort is to use the spare half of DRAM to accommodate it directly. These fall-back strategies ensure that garbage collector performance degrades gracefully rather than failing with a bang. The sweeping of unwanted objects from disk is a software housekeeping problem that should take place off-line.

The finite limit on object numbers raises a potential problem

(even though 2^{38} numbers is quite a lot) because they are allocated sequentially by a counter. When you kill an object you theoretically free up its number, but you can't just reset the counter to reflect the fact. What happens when you run out of numbers? Rekursiv tackles this problem in two different ways.

One solution is conservative: Don't squander precious object numbers on very common data items that tend to be consumed and forgotten. The top 2 bits of a 40-bit object number are used as flags, so the real object number is only 38 bits long.

The top bit says that this is an object number to distinguish it from an untyped binary value (these are permitted in Rekursiv but can only exist embedded inside objects; they help to conserve object memory). The next bit distinguishes between normal and "compact" objects whose remaining 38 bits hold a 5-bit type identifier and 32 bits of actual data rather than an object number. Such compact objects ought to be used to hold numbers, characters, strings, pixels, and so on. Compacts are reminiscent of the way Smalltalk handles SmallIntegers. The Rekursiv hardware knows about compact objects and extracts their data directly so they consume no object memory and can be accessed quickly.

The other solution is radical: Rekursiv garbage-collects object numbers in an operation totally distinct from garbage-collecting the objects themselves. This operation needs to be performed only infrequently, and it could be done during an off-line period such as a maintenance break when all objects are resident on disk. A compaction utility writes a new disk image of all the objects, renumbering them with consecutive numbers, and then

continued

If our Economical New DigiChannel/Xe Intelligent Multi-Channel Communications Board doesn't fit your application, read our ad on the left.

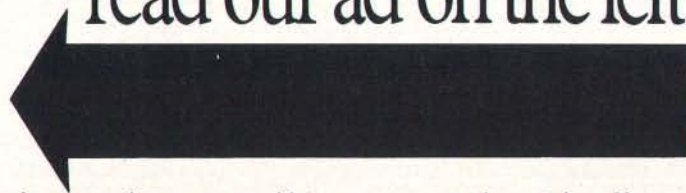

See us at
UNIX EXPO
and
COMDEX FALL

Because of our long experience, we provide engineering and support others can't. What's more, we listen. You've asked for a product that does its job — without all the "extra" features you don't need.

That's why we're introducing the DigiCHANNEL/Xe. Its 8 MHz 80186 co-processor makes it significantly faster than our former model —

yet it costs less. You can still choose between 4 or 8 asynchronous channels, and 64K of SRAM is more than enough for such straight-forward multi-user and multi-channel applications as data collection and office automation. So if the new DigiCHANNEL/Xe sounds like a good fit, call us for more information.

If not, read our ad on the left.

DigiBoard
Plugging you into tomorrow.

Call 1-800-344-4273. In Minnesota, (612) 922-8055.

Listing 1: A Lisp function that copies a tree structure.

```
(DEFUN Copytree (Item)
  (COND ((ATOM Item) Item)
        (T (CONS (Copytree (CDR Item))
                  (Copytree (CAR Item))))))
```

Listing 2: A Rekursiv instruction equivalent to the Lisp function shown in listing 1.

```
MICRO$COPYTREE: entf 1 pagebus d=ustack
  crtfc IDXBADTYPES newtrbr _CONS
  incmsp m.sp' newmptr
  jf MICRO$COPYTREE ldustk d=pgrorr
                                     // the CDR branch
m.fp 1 uaddr newmptr
readustk
pagebus d=ustack
idx2 newsr newbr loadaddr
idxget nocheck incmsp m.sp' newmptr
jf MICRO$COPYTREE ldustk d=memout
                                     // the CAR branch
js RTN$CONS
rtf
```

resets the allocator's counter to the next available number.

One implication is that no references to object numbers can be allowed to exist outside the Rekursiv universe, since these would escape renumbering and become corrupt. Since Rekursiv is meant to be programmed only at the symbolic level (e.g., as in Smalltalk), this prohibition doesn't prevent you from storing program code outside the machine; but it is a symptom of a more profound philosophical problem that all those who build distributed databases (e.g., the hypertext movement) will eventually face.

The size of the pager table raises another theoretical problem: If you have a program with more than 65,536 objects, then hash collisions are possible (though pretty unlikely). In the case of a table collision, Rekursiv just squeezes the old object from that slot out to disk.

The Microcode

The Rekursiv is an object-oriented database engine for creating and managing persistent objects and, with strict type-checking, performing just about any operation on them you can think of. Since the Rekursiv has a writable instruction store, it will come out of the box absolutely empty and is incapable of doing anything at all until the microcode for an instruction set is loaded into the control store part of the SRAM. Of course, Linn does not expect potential users to dive headfirst into microcode programming, and so the production machines will be supplied with at least one instruction set.

A standard instruction set that supports C, together with the

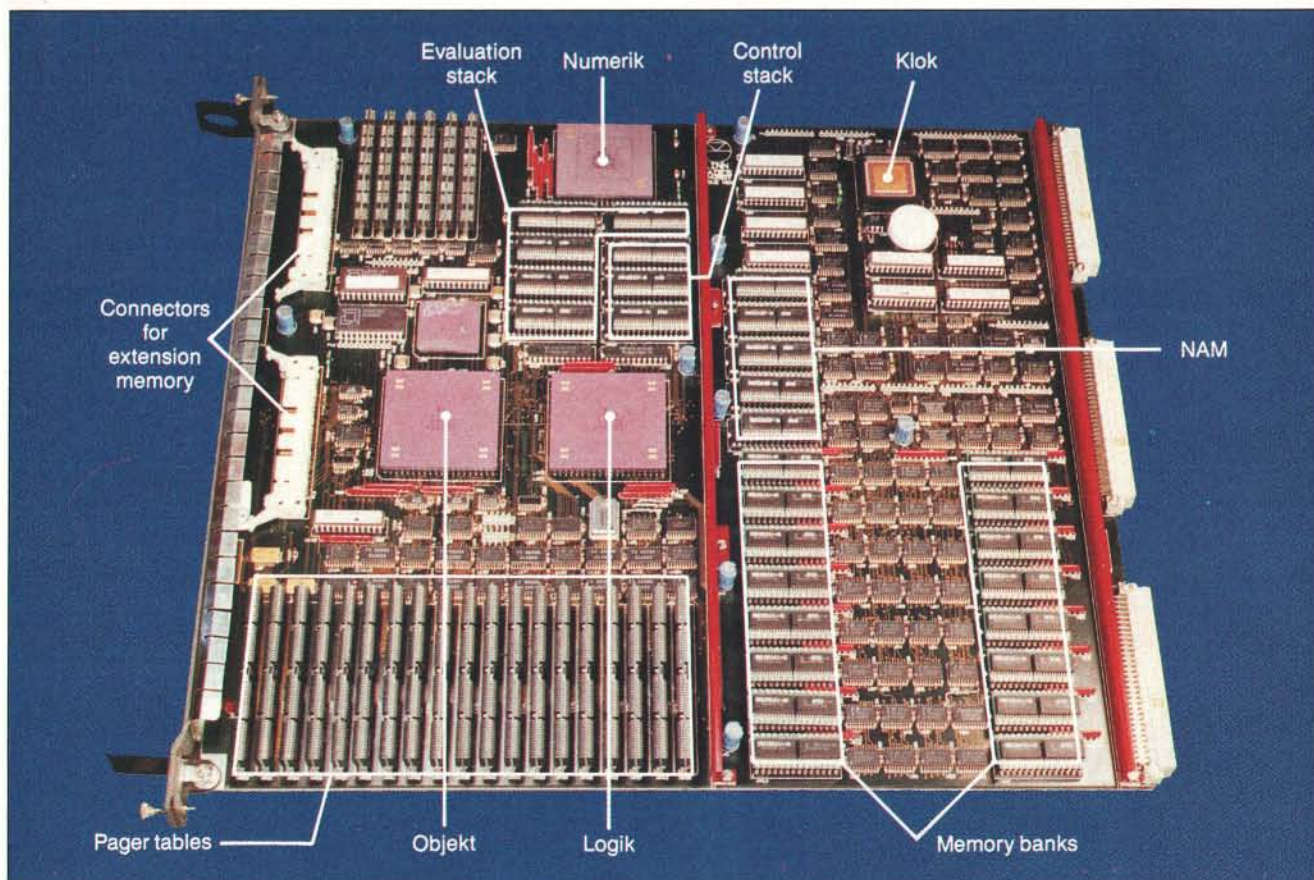

Photo 1: This VME board, called HADES, is the first working Rekursiv system. The main units are three gate arrays called Numerik (the ALU), Logik (the sequencer/stack unit), and Objekt (the object memory manager).

corresponding C compiler, will be supplied for writing application programs. Far more interesting, though, is a second instruction set, a microcoded Smalltalk interpreter, that makes far better use of the Rekursiv's unique features.

The microcode is stored in the control store, an SRAM area with its own 16-bit bus, where there is room for 16,384 control words of 128 bits each. Another separate memory space, called the control store map, holds a table of 2048 microcode start addresses, and maps 10-bit op codes onto the microcode that implements them. This function is equivalent to the instruction decoder of a conventional processor that would normally be hardwired logic. The control store and map can be thought of as a Smalltalk-style bytecode interpreter implemented in hardware.

Where does the processor keep its program code? So far, we have only seen object store memory, which, in conventional terms, might be thought of as data memory. In fact, op codes can be contained in objects and thus can be stored in the main object store, from which they must be fetched as in a conventional processor. For frequently performed operations, though, there is an alternative that offers much higher performance.

The block called NAM & NAMARG in figure 1 is the New language Abstract Memory that stores up to 524,288 words of 10-bit op codes and their 30-bit arguments that form abstract or high-level instructions. Since the NAM is inside the processor, it behaves like a fast instruction cache and creates a two-tiered system for language implementation.

First, you choose the set of primitive instructions best suited to supporting the specific language and write them in microcode. Now you have a customized assembly language, and you could write a compiler that generates these primitive instructions directly as its output; this is how C will work. But for advanced languages like Smalltalk, Lisp, or Prolog, you would use this abstract assembly language to write a set of interpreter subroutines and make them resident in the NAM. In the case of a Smalltalk implementation, the abstract code in the NAM would be the *methods* of the most important system classes.

Methods for user-defined classes would be contained in objects in the main memory and would thus incur a memory fetch, though you might be able to "freeze" important code into NAM. This two-tiered structure should allow Rekursiv to support these artificial intelligence languages that are traditionally interpreted almost as efficiently as a fully compiled language.

As a sample of what Rekursiv microcode looks like, the fragment in listing 2 is a recursive instruction that copies a tree structure, equivalent to the Lisp function shown in listing 1.

The microcode for MICRO\$COPYTREE calls an auxiliary instruction, named CONS, as well as calling itself in two places. Simulations of this code suggest that when running on a 10-MHz Rekursiv, it will create a new CONS node every 2 microseconds, some 20 times faster than Lisp on a Symbolics 3675 workstation. In the course of writing a Prolog interpreter, Linn's programmers have also implemented Prolog unification as a single instruction.

HADES and the Real World

Linn has plans to use the Rekursiv architecture in several products: an accelerator board for existing engineering workstations like those from Sun, Apollo, or MicroVAX; a networked Rekursiv-based workstation; and the full multistation control system for flexible manufacturing that was the original goal of the project. The Rekursiv chip set will also be sold to OEMs.

The three custom chips are all fabricated in a 1.5-micron CMOS process and packaged as 299-pin ceramic pin-grid arrays. Numerik is a fairly conventional 32-bit ALU compatible with the AMD 29203. It has a full 32-bit multiply with a 64-bit

result and a built-in 32-bit barrel shifter. Logik is the sequencer/stack unit; it controls the control store and map, the stacks, and the NAM. Objekt is the object memory manager that controls the pager tables to get the addresses of objects and performs range- and type-checking. In addition to these three, there is a programmable timer chip called Klok.

So far, Rekursiv has only existed as a microcode-level simulation, but the three main application-specific IC chips have now been fabricated by LSI Logic Ltd. and, as this article is being written, only the circuit board remains to be made. The first working Rekursiv system will be a VME board called HADES (Hardware Accelerator for Dynamic Expert Systems) that plugs into the back of a Sun-3 or Sun-4 workstation (see photo 1). HADES is built from the three custom chips, 2 megabytes of 45-nanosecond SRAM, and 5 megabytes of 100-ns DRAM object store on a quadruple extended Eurocard (a longer-and-wider-than-standard printed circuit board). HADES will employ a partition on the Sun host's hard disk to page the object memory, and this setup will cramp performance considerably due to the limited bandwidth of the VME bus. Later versions will incorporate their own close-coupled hard disks with fast direct-memory-access transfer into object memory. A 10-MHz Rekursiv reading consecutive words from object memory in one cycle each reads 50 megabytes per second. You would need to use a disk capable of a transfer rate of this order to avoid a paging bottleneck.

HADES acts as a VME bus slave and interrupter, which means it is completely controlled in two ways by the Sun host to which it is interfaced. The control store is memory-mapped into 2 megabytes of Sun/VME memory space so an instruction set can be written into it. Reading from a control store address executes the microcode at that address. Four 32-bit registers, two for reading and two for writing, are used to communicate with the Rekursiv's main data bus. A typical way to program HADES from the Sun would be to load the Smalltalk instruction set and then send a stream of ASCII codes representing a Smalltalk program to these registers, whereupon the Rekursiv acts as a hardware interpreter and executes them. It's very desirable to program the Rekursiv in such a high-level, symbolic fashion to avoid having to refer to absolute object numbers in the program code. Otherwise, object number references could be removed from the machine (e.g., in a program stored on a backup streamer tape), and these numbers could escape the periodic object number compactions and so become invalid. When using Smalltalk as the programming language, symbolic object names would be mapped to Rekursiv object numbers only by a dictionary that exists *inside* the Rekursiv itself.

A Rekursiv Future?

I find the Linn Rekursiv an interesting development for several reasons. Its sheer originality offers some relief from the flood of "me-too" RISC chips that threaten to drown the industry.

If Rekursiv delivers its promised performance, we may, at last, see Smalltalk becoming a viable production language. What interests me most is that Rekursiv could be a powerful testbed for developing new object-oriented languages. The foundations of Smalltalk were laid in the 1970s, and it represents the infancy, not necessarily the pinnacle, of object-oriented programming. Object-oriented databases could be the next hot commercial product. Since Rekursiv does most of the work for you in hardware, I expect it to do well. ■

Dick Pountain is a BYTE contributing editor, a technical author, and a software consultant living in London, England. You can contact him on BIX as "dickp."



*"When you have a department of one-man bands
all you produce is a chorus of chaos."*

If you manage an organization with more PCs and peripherals than you care to count, maybe you should consider tying them together — with a STARLAN Network from AT&T.

Supporting a wide range of DOS and UNIX® servers for workgroups of all sizes, a single STARLAN

Network can link from 2 to over 100 DOS PCs, so independent-minded standalones can effectively function as one. Which means users can share printers, retrieve and edit common documents, update centralized databases and send or receive messages electronically.

AT&T's modular architecture and twisted-pair

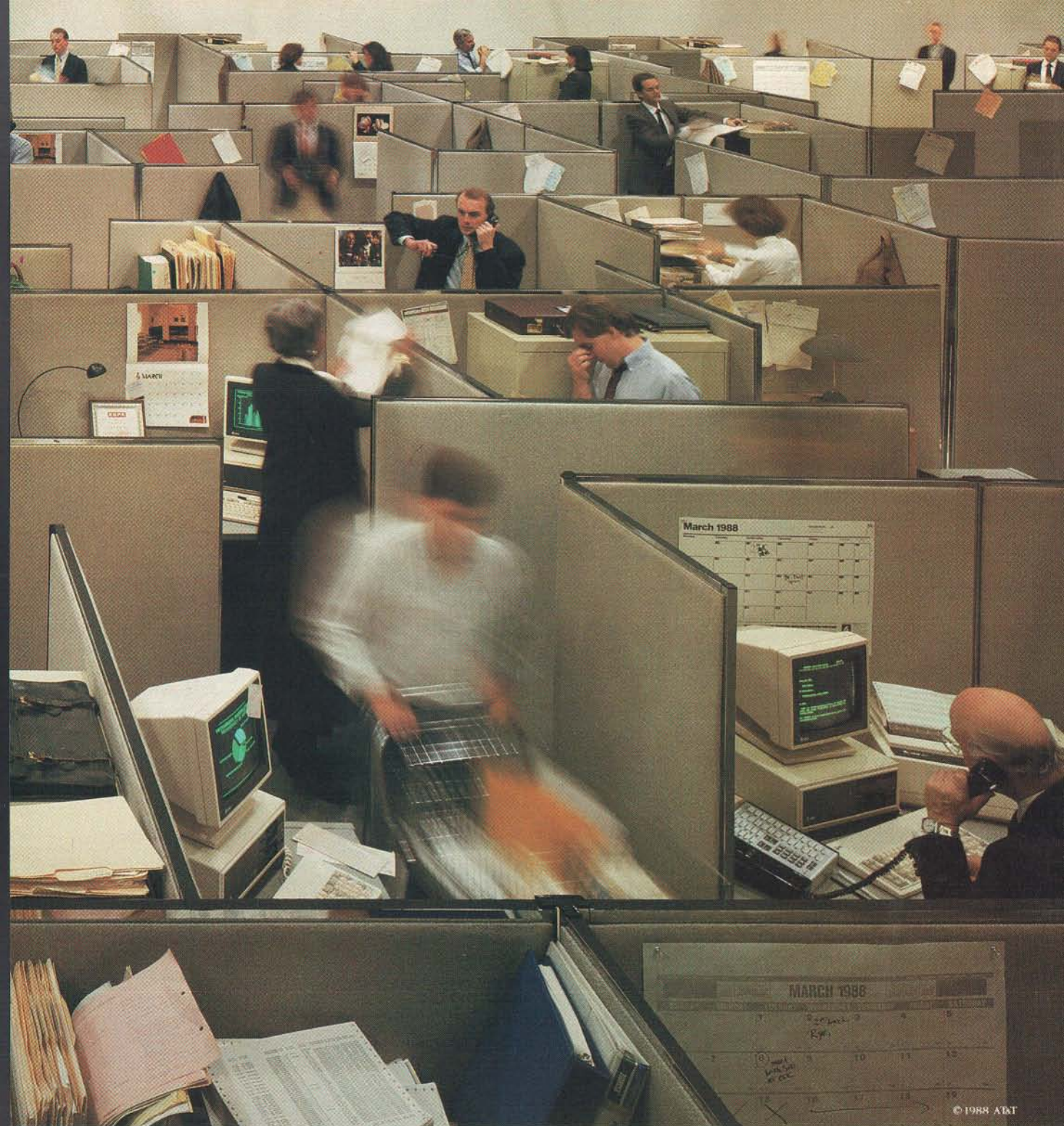

© 1988 AT&T

wiring make it easy for you to add voice and data stations the same way you add staff: as needed.

And by connecting your STARLAN Network to AT&T's Information Systems Network, virtually all the information-processing equipment in your company can become a fully integrated, cost-efficient system.

To find out more, call 1 800 247-1212.

From equipment to networking, from computers to communications, AT&T is the right choice.



AT&T
The right choice.

NOVEMBER 1988 • BYTE 351

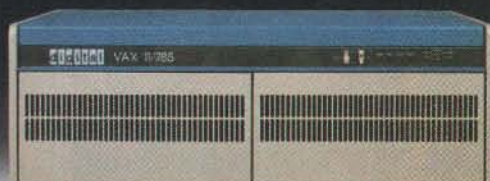

Use Premium Fuel Only.

Ditto.

Take ½ gallon of gasoline formulated for high-performance motor cars.

Add a clod of dirt, a quart of kerosene, a tablespoon of sugar, and a dollop of axle grease. Sprinkle with rust particles and dog hairs. Stir.

You'd be *crazy* to put *that* in your Ferrari, right?

But what we've just concocted is the petroleum equivalent of a kilowatt of ordinary electricity.

Emerson UPS's Provide Clean Fuel For Computers.

Since today's computers are no less high performance machines than the most sophisticated automobiles, they need highly-refined fuel, too.

An Emerson Uninterruptible Power Source is the *electrical* equivalent of a petroleum refinery. Raw fuel in, good fuel out.

Such a simple solution to all the harm spikes, sags, and blackouts can do.

Unrefined Electricity Does Crude Things To Computers.

Unlike bandsaws, washing machines and tv's, computer circuits are hypersensitive to the slightest power variations. Data can be scrambled or vaporized in a few milliseconds. Programs can crash unceremoniously.

Fact is, many problems blamed on hardware or software are, in reality, the fault of raw electricity. Industry statistics show that half the downtime, lost employee and machine productivity, and maintenance costs are the direct result of bad electricity.

A typical computer site experiences about 7 blackouts, over 500 sags and more than 2,000 spikes and surges per year. Plus there's almost continuous line noise at even the best locations.

Power surges alone are credited by one insurance company with \$35 million in pc losses just last year.

Any way you look at it, making sure your computer gets premium fuel is up to you. Fortunately, it's easy and affordable.

UPS Performance And Throughput.

Most people think of Emerson UPS systems as just battery backup

protection against power outages.

In reality, they're also the best power *conditioners* money can buy. They work *continuously*, uniquely providing an impenetrable barrier that isolates your computers from power problems.

The result: You get the level of performance your computer was designed to deliver. The level you paid for.

The High Performance UPS Manufacturer.

Emerson makes a full line of UPS, power conditioning and distribution systems, even simple surge protectors.

All feature quiet operation, attractive design, UL-listed safety, operation that is one-switch simple, and proven reliability backed by the best service in the business.

So, let us help you rev up your productivity. **Simply call 1-800-BACK-UPS** for our free introductory brochure and the name of your local representative. Or write: Emerson Computer Power, 3300 S. Standard St., Santa Ana, CA 92702.



EMERSON
Computer Power

Computers Won't Run Right
On The Wrong Fuel.

PC Power, Part 2:

BACKUP POWER

How do you provide reliable backup power for your computer without creating new electrical problems—and how much will that cost you?

Mark Waller

When the utility power fails, your computer won't work. You may think the solution to this problem is an uninterruptible power supply. A UPS device supplies continuous power to the computer whether the utility power is flowing or not. However, in the world of personal computers, backup power systems are generally standby power systems, or SPSes. These devices switch on when utility power fails. This distinction of switching or not switching is the basic functional difference between a UPS and an SPS.

The main task of these products is to keep your computer running when utility power fails, as opposed to surge suppressors or power conditioners whose main task is to protect your computer. Backup power and power protection are areas of vital importance—especially if your investment in computing includes a local area network (LAN) or desktop publishing system. It is vital that you know the difference between backup power and power protection. Since SPSes are not all alike, you must be vigilant; otherwise, not only will you waste your money, you may end up with additional power problems.

Standing by . . .

The building blocks of an SPS include the battery, the battery charger, the transfer

switch, and the inverter (see figure 1). Most of the time, raw utility power is fed into the computer. All the while, though, the battery charger keeps the battery ready in case the power should fail. If power does go out, the transfer switch senses the outage and turns on the inverter, which provides AC power by drawing energy stored in the battery. After power is restored, the switch turns off the inverter and transfers the computer back to utility power.

That process sounds simple. Theoretically, it is. But different brands of SPSes handle this situation with varying degrees of efficiency. There are many functions that an SPS must provide during this simple-sounding process. It must, for instance, recognize at what point the utility power has failed and whether or not the voltage must drop out completely before it makes the transfer. It must also decide how fast it will make the transfer once the process is initiated. The way an SPS deals with these tasks determines the effectiveness of the product.

A better SPS will switch over to battery any time the utility voltage drops below a certain preprogrammed level; say, 103 volts. Low-budget units often have less-expensive sensing circuits that may not transfer to battery until the power drops significantly. Since every manufacturer

continued

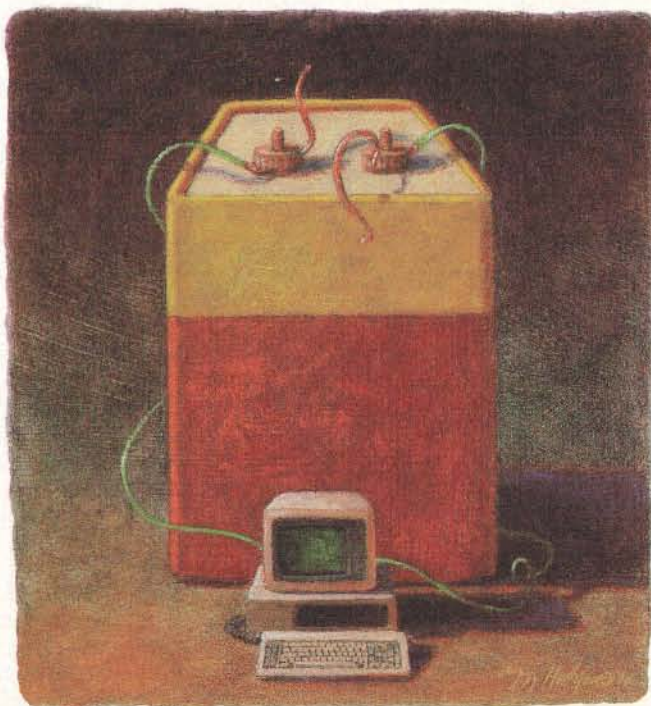

rates its SPS in terms of transfer time, how they calculate this time is critical.

Your computer's power supply has some capability to store electrical energy so it can ride-through extremely short-term outages. The term *ride-through* refers to the power supply's ability to deliver stored energy to the computer even when its power supply has lost incoming power. As a general rule, your computer can tolerate outages from 20 to 30 milliseconds before it goes down. If your SPS can transfer to battery power within that time frame, you should be able to stay operational. Generally speaking, the less-expensively constructed your power supply, the less time it will be able to sustain the computer through an outage.

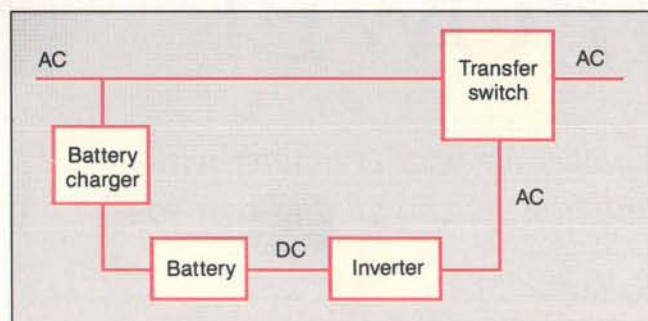

Figure 1: The building blocks of an SPS are the battery and the inverter. The battery powers the inverter, which converts DC into AC. Notice that these blocks only operate when the transfer switch senses that utility power has failed.

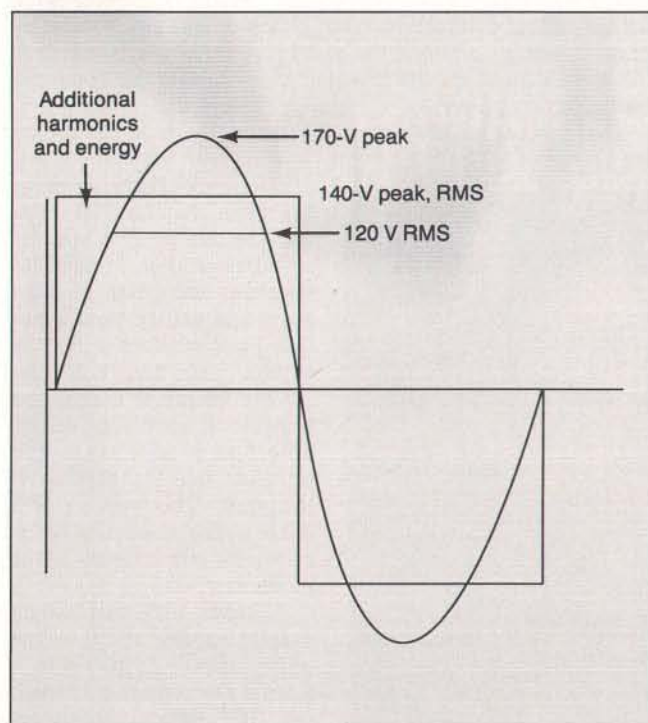

Figure 2: A comparison of the sine wave generated by utility power and the square wave produced by many SPSes. At any given point along the graph, a square wave contains more energy than a sine wave. Its peak voltage is equal to its RMS voltage.

Most manufacturers claim their devices have from 4- to 10-ms transfer times, which is within the ride-through time of the computer's power supply, and you should have no problems keeping your system up when the power goes down. If, however, the voltage drops for several milliseconds before the unit senses the outage and this time increment is not taken into account, the stated transfer time may be well under the actual transfer time. Reputable companies include the time it takes to sense an outage in their total transfer-time calculation.

If 4 to 10 ms is good, wouldn't 2 ms be better? Some companies boast that their devices have transfer times of 2 ms or less. Reaction times as fast as these can cause the inverter to kick in and out, constantly draining the battery every time a short-term drop in voltage occurs. The point here is that you don't need your SPS continually reacting to events that are not outages but simply fast fluctuations on the line.

Thus, transfer time is a trade-off between the computer's ability to ride through small power glitches and the need to provide quick backup power in case of a real outage. The fact that computers will tolerate such a long time without power leads most manufacturers to advertise their products as UPSes instead of SPSes—a questionable practice, and you should know the difference before you buy.

Riding the Wave

Utility power is a 60-Hz sine wave. You might just assume that your shiny new SPS will generate just such a sine wave. But, if you look at the fine print in the specifications, you may very well see terms such as *square wave*, *rectangular wave*, or *modified square wave*. Sometimes the literature will even show a picture of a great-looking square wave. Of course, you won't know if, when the picture was taken, the SPS was under load, or if the load was a switching power supply such as that inside your computer, or simply a plain old light bulb.

Figure 2 shows a comparison between a sine wave and a square wave. A square wave is a compromise between cost and quality. Since an inverter incorporates digital switches that turn on and off, it is less expensive to design an inverter to produce a square wave. But since a square wave's peak voltage is equal to its root-mean-square voltage, designers must compromise on a level somewhere between the normal 170-V peak of the utility sine wave and its RMS voltage of 120 V—usually around 140 V.

A 140-V square wave provides too little voltage with too much energy for the standard computer loads. A square wave at any given point along its curve contains more energy than a sine wave. Some engineers claim that your computer's power supply needs a minimum of 148 V RMS. The additional energy in a square wave will cause power-supply overheating and stress.

One school of thought preaches that a well-designed square wave is the best waveshape for switching power supplies since the switching power supply draws current in a nonlinear fashion. Engineers may argue, but you must be able to determine if the product is well designed, or it may produce the kind of waveshape shown in photo 1. This is the "modified" square wave generated by dozens of SPSes on the market. This waveshape will change as the load increases in order to keep the RMS voltage at the proper level, and it may even look more like a square or a rectangle.

On the other hand, when manufacturers go to the trouble of producing a sine wave, the output will likely be electrically cleaner than the average square wave.

A potential problem with an SPS inverter's waveform output is its high-frequency noise content. This noise can damage your computer components or interfere with your processing. Many

inverters use pulse-width modulation. PWM is a means of producing a desired waveform using high-frequency switching. The SPS filters out high-frequency components of the resultant signal, and the effect is a sine wave of low harmonic content with relatively little noise output. (Harmonic content refers to multiples of the fundamental frequency of the intended waveform. These multiples may cause distortion of the waveform, or high-frequency harmonics may appear as noise.)

In spite of this filtering, some of the switching noise will leak through and appear on the output. Square and rectangular waveshapes have a greater tendency to produce noise, since the waveshapes contain harmonics of the fundamental 60-Hz power signal and are created by large switching pulses.

Photo 2 shows the high-frequency content of the modified square wave in photo 1. You may think this looks harmless. Consider the fact, however, that these noise impulses occur about three times every cycle and are about 350 V in magnitude. If you buy this model, you may save around \$50 over a better-engineered model, but you may put your computer in danger every time your utility power fails.

Synchronicity

After the SPS has been operating off the battery and utility power returns, two things must happen. First, the sine-wave output of the SPS must synchronize with the incoming utility power. This process is sometimes called *phase matching*. Then the unit must switch from battery power to utility power.

These operations sound fairly simple; the term describing them is *retransfer*. Most inexpensive units do not synchronize, however, and synchronization is important. Your computer's power supply is designed to expect the peak voltage of the sine wave to occur at regular intervals. If the peak of the sine wave is missing for very long, your computer may crash. When the SPS is on battery power, it generates its own sine wave or square wave according to its own internal clock. When utility power is restored, the sine wave's phase may not match that of the SPS. In order to prevent a mismatch, and perhaps a system crash, the SPS must slip sideways: *slew* its sine wave to match the phase of the utility wave before retransferring.

The SPS must also decide at what voltage level it should initiate retransfer. Normally, this level is a different, higher voltage than the transfer voltage. For instance, if the SPS transfers when the voltage falls below 103 V, it may wait until the voltage rises to 108 V to retransfer. This process avoids "dancing" on and off the inverter if the voltage hovers at a level near the transfer point.

Many SPSes provide selectable transfer points for site-specific considerations. If your location has periodic brownouts, you may want to set your SPS to a low transfer point, such as 90 V, to avoid constantly draining its batteries.

Battery Basics

The concept behind providing backup power for your computer is to give you enough time to save your work in volatile memory and bring your system down safely. SPSes are not designed to give more than a few minutes of backup power. If you need much more backup time than that, you may have to modify an existing unit to accommodate a larger number of batteries. There are some models that allow for this option.

The amount of battery time you need is a function of the kind of processing you do. You may, for instance, have an accounting package that needs several minutes to complete a task. Many manufacturers gamble that you are only going to load your SPS to about 60 percent of capacity, and in order to achieve smaller, sleeker packages, they may undersize the bat-

tery. If your actual load is 300 watts, you may want to give yourself additional capacity and buy a 500-W SPS. Compare one manufacturer's cabinet to another's. All things being equal, the size of the cabinet itself will tell you which unit will give you every minute you need.

Another battery-related feature you should consider is called automatic shutdown. If your SPS's battery completely drains, it may fail prematurely and not last nearly as long. And, short of total drainage, there is a point, called the end voltage, beyond which additional discharge will cause damage to the battery's cells.

SPSes that come with a built-in automatic shutdown function will probably cost a bit more, but this type of device may prove to be a bargain if your batteries last twice as long as those in a less expensive model.

continued

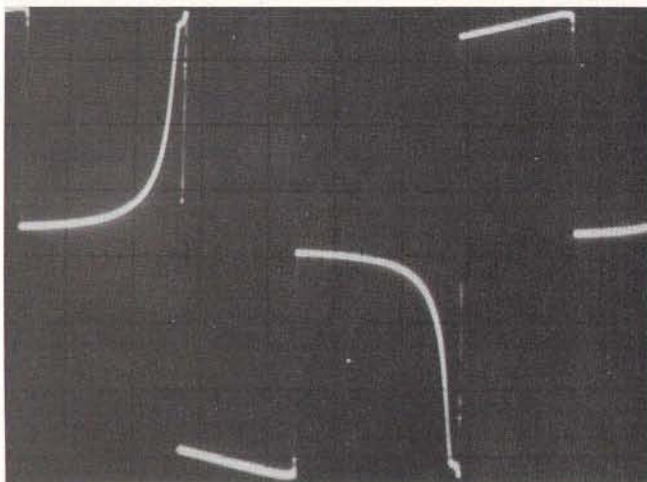

Photo 1: The modified square wave produced by many inexpensive SPSes. This waveshape changes to correspond with the increasing demands of the load in order to maintain the designed RMS voltage.

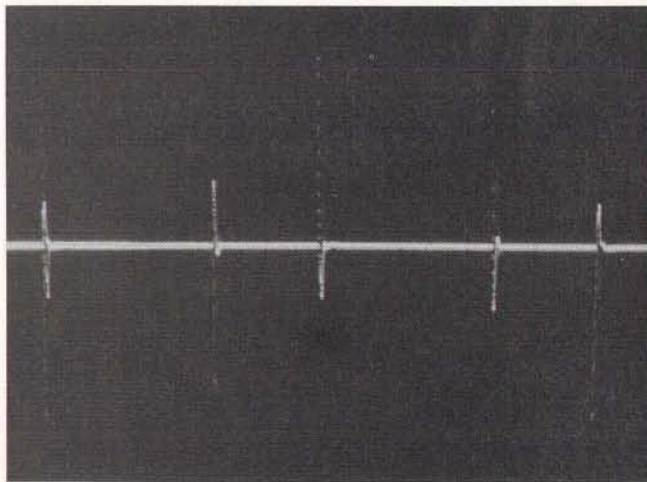

Photo 2: These innocuous-looking spikes are the output of the typical inexpensive SPS. They are actually 350 V in magnitude and can be the source of stress on your computer's power supply; they may even cause processing errors or damage to your computer's ICs.

Spike Those Rumors

Many manufacturers advertise that their SPSes are also power conditioners, which might make you think that you are protected from noise and spikes as well as blackouts. But SPSes are not cure-alls. This "conditioning" usually means placing one or more metal-oxide varistors deep inside the SPS (see "PC Power, Part 1: Power Protection," October BYTE). This is an inexpensive way for manufacturers to claim they have provided you with a surge suppressor. But a surge suppressor is an inferior form of power conditioning. To expect this conditioning to be much more than window dressing is wishful thinking.

The Ideal Product

You might think that the ideal product would be an on-line UPS. This concept is partially correct. The difference between

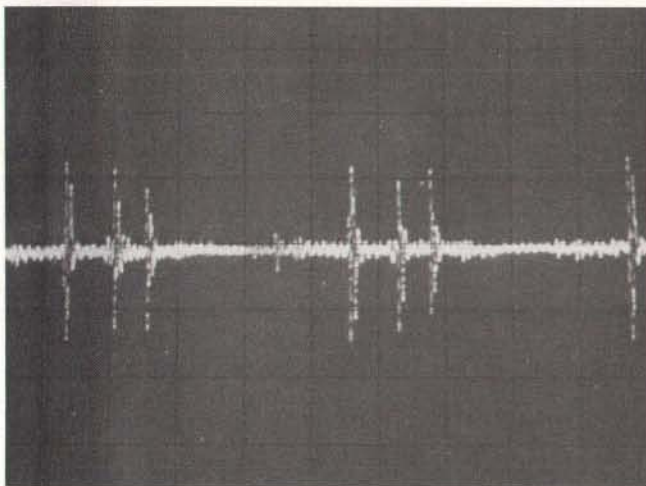

Photo 3: This photo shows common-mode noise present on the line before insertion of an on-line UPS. Common-mode noise can be the most damaging form of noise.

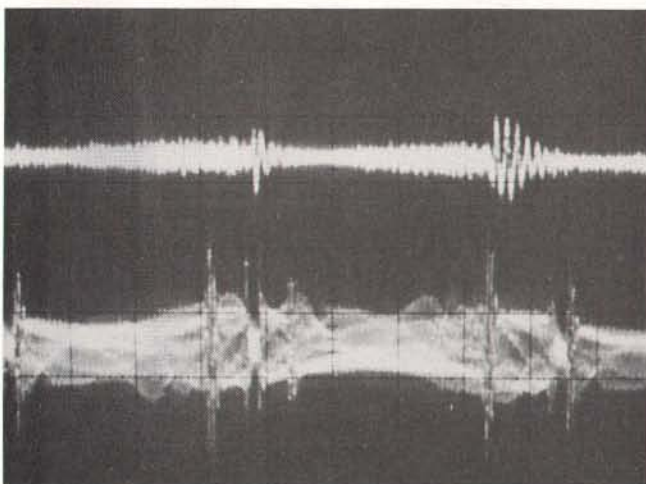

Photo 4: Normal-mode noise (top trace) and common-mode noise (bottom trace) after the insertion of an on-line UPS. The top trace contains a small amount of noise from the UPS's inverter. The bottom trace shows inverter noise superimposed over the common-mode noise present in photo 3. As you can see, the UPS has contributed to, rather than eliminated, common-mode noise.

a true UPS and an SPS is that in the UPS, the inverter powers the computer at all times. The incoming utility power is converted to DC by a rectifier/charger that transfers power to the inverter over a DC bus. The batteries are connected to this DC bus and, if the utility supply should fail, can provide instantaneous power to the computer—there is no switching time to worry about.

In a UPS, the inverter and rectifier/charger are on-line all the time. Thus, they are larger and more substantial than those found in an SPS. This fact makes the cost of a comparable UPS three to five times that of an SPS. Specialized peripherals such as some large external hard disk drives might not be able to tolerate the switching times of an SPS.

Because of the AC to DC to AC conversion, the on-line UPS provides an excellent barrier to normal-mode noise (again, see last month's article). But the on-line design does little to suppress common-mode noise.

Photo 3 shows the common-mode noise present on the power line. Photo 4 shows the common-mode and normal-mode noise present after the insertion of an on-line UPS. Notice that the PWM inverter inside the UPS produces only a few volts of normal-mode noise (top trace). But the inverter generates about 30 V of common-mode noise, which you can see superimposed on the noise already present in photo 3.

In my previous article, I concluded that a power-line conditioner is the best product to protect your computer. The heart of this device is an isolation transformer with the neutral to ground bonded on the secondary. On the other hand, if you are concerned with blackouts, a properly designed SPS will carry you through outages. But, since it is not on-line all the time, there is no ongoing power protection.

The ideal product would seem to be a combination of power conditioner and SPS. In fact, one company recently announced a product that combines the two in one cabinet. But at \$1500 for approximately 500 W, it is out of reach for most of us—although this price is less than that of many on-line UPSes of the same size.

A marriage between a power-line conditioner and an SPS is the best solution. The most effective way to connect the products is to plug the SPS into the wall, and the power conditioner into the SPS. This way, you are conditioning your power even when it is provided by the battery and inverter. The conditioner takes care of any SPS-generated noise.

Protect your LAN

The industry is just beginning to see the results of the computing revolution that networking has brought about. The economic value of data being handled via LANs is greater than ever before because there are multiple users who depend on the data. Networked data is often constantly updated by a file server and a large hard disk drive. They must be protected at all costs. In addition to mere protection, you must also be concerned with outages because they are the source of head crashes, downtime, and lost data.

Therefore, it is essential that you obtain an SPS to back up the file server and associated hard disk drive. Backup power is a necessary element in the success of a LAN because the network will not work for you if you don't learn to rely on and trust its performance.

Not only should you use an SPS for backup power, you should also use its external alarms, which will trigger LAN software to alert other users that they are on battery power and have only minutes to close their files and shut down. Remote users, whose power may be coming from a source that hasn't

continued

PCYACC™

Version 2.0

PCYACC Version 2.0 is a program generator capable of automatically generating ANSI C source code for building Assemblers, Compilers, Browsers, Page Description Languages, Language Translators, and Query languages.

Complete grammars and lexical analyzers for ANSI C, C++, ISO Pascal, DBASE III/Plus, SQL, Smalltalk, and YACC are included.

Example application sources are provided to be used as skeletons for new programs. Examples include a desktop calculator, an Infix to Postfix Translator, a DBASE III/Plus Syntax analyzer, an implementation of the PIC[ture] language, and a C++ to C translator.

PCYACC is input compatible with UNIX YACC when used with C grammar descriptions.

- Quick Syntax analysis option
- Optional Abstract Syntax Tree
- Advanced Error Recovery Support Provided
- All examples include FULL SOURCE listings
- Manual "Compiler Construction with PC'S" included
- 30 day money back guarantee

Professional version \$395.00



**ABRAXAS
SOFTWARE, INC.**
7033 SW Macadam Ave.
Portland, OR 97219
(503) 244-5253
FAX (503) 245-1110

QUALITY NEC PRODUCTS DESERVE QUALITY NEC SERVICE.

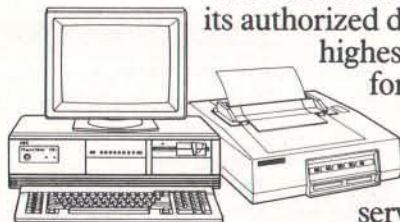

NEC Customer Engineering and its authorized dealers offer you the highest quality service for your NEC computer and printer. From walk-in, on-site and mail-in service to maintenance

contracts and spare parts, NEC gives its customers professional and comprehensive support. Call us, and find out about the many ways NEC Information Systems takes care of its own.

Service Excellence Through People, Pride and ProfessionalismSM

1-800-325-5500

CoC COMPANIES AND COMPANIES

NEC

failed, especially need this feature.

Local users should also have backup power, or the file server should be able to use battery time to bring users back to their files gracefully.

Of course, you should use a power-line conditioner to protect your hard disk drive and its valuable data from destruction. Es-

With an
*expensive computer, you shouldn't
scrimp on power products.*

entially, a LAN is just one big ground loop with several power sources and cables running all over. You should make every effort to provide a noise-free power environment so you will avoid degradation of your data.

Publish or Perish

A desktop publishing system is usually a state-of-the-art computer with a high-speed processor, a large hard disk drive, a tape backup, and a laser printer. With an investment of this magnitude, you shouldn't scrimp on protection; what comes down the power line can seriously damage your system.

The typical laser printer draws as much as 1000 W, and this can be a problem. Thousand-watt power conditioners are expensive. Your only less-expensive option is a surge suppressor. If it is properly designed, a surge suppressor should protect the printer well enough to prevent any major damage. A laser printer, after all, is a lot more like a copier than a computer on the inside.

In a desktop publishing environment, backup power is essential for the computer, but not necessarily for the printer. If a printing function is disrupted by an outage, it may be a nuisance, but the job can be done again. The computer, on the other hand, has large and rather lengthy processing chores. It makes sense to provide it with an SPS to ensure that jobs finish and files are closed before power shuts down.

Buy Safe, Not Sorry

Many people spend thousands of dollars on hardware and software, only to dash out and buy the least-expensive protective and backup power products they can find. You will waste your money on this strategy and leave your system vulnerable, and you may even introduce undesirable noise into the electrical environment.

To obtain devices that provide you with a safe personal computing system, you should invest the same amount of thought and evaluation as when you selected your computer to begin with. The process will vary depending on your needs and your particular system configuration.

Armed with the facts, you can make informed buying decisions and then relax and let your investment in computing work for you. ■

Mark Waller is a computer facilities consultant and the author of Computer Electrical Power Requirements and Mastering PC Electrical Power, both published by Howard W. Sams. He can be reached on BIX c/o "editors."

MINUTEMAN[®]

UNINTERRUPTIBLE POWER SUPPLIES

"More Powerful Than Ever!"

TOTAL POWER PROTECTION

BLACKOUTS Enables user to operate during complete loss of power.

BROWNOUTS User is protected from low AC voltage below 102 volts.

OVERLOADS Automatic shutdown in overload situation to protect UPS from inverter burnout.

OVERVOLTAGE UPS runs on inverter (117 volts) when AC voltage exceeds 132 volts.

SURGES/SPIKES Clamps transients above 200 volts with an energy rating of 100 joules or less.

EMI/RFI Three stage filtering for clean AC power.

- FULL ONE YEAR WARRANTY
- ORDER-SHIP SAME DAY
- 1 MILLISECOND TRANSFER TIME*
- SYNCHRONIZED SINEWAVE*

*250 watt and 500 watt units offer 4 msec transfer time, PWM waveform



PARA SYSTEMS, INC.

1455 LeMay Dr.
Carrollton, TX 75007

Telephone:
(214) 446-7363

1-800-238-7272

FAX: (214) 446-9011 TELEX: 140275 OMEGA

Power Output	120 Volt Models	230 Volt Models
250 WATT	\$ 379.00	\$ 429.00
300 WATT	\$ 549.00	N/A
500 WATT	\$ 699.00	\$ 799.00
600 WATT	\$ 899.00	\$1049.00
1200 WATT	\$1499.00	\$1749.00
1600 WATT	\$1999.00	\$2299.00

Suggested Retail



Optional Battery Packs Not Shown



250, 300 and 500 Watt Models

See us at
COMDEX/Fall '88
November 14-18, 1988
Las Vegas Convention Center
Booth #163

Computer of the Year.

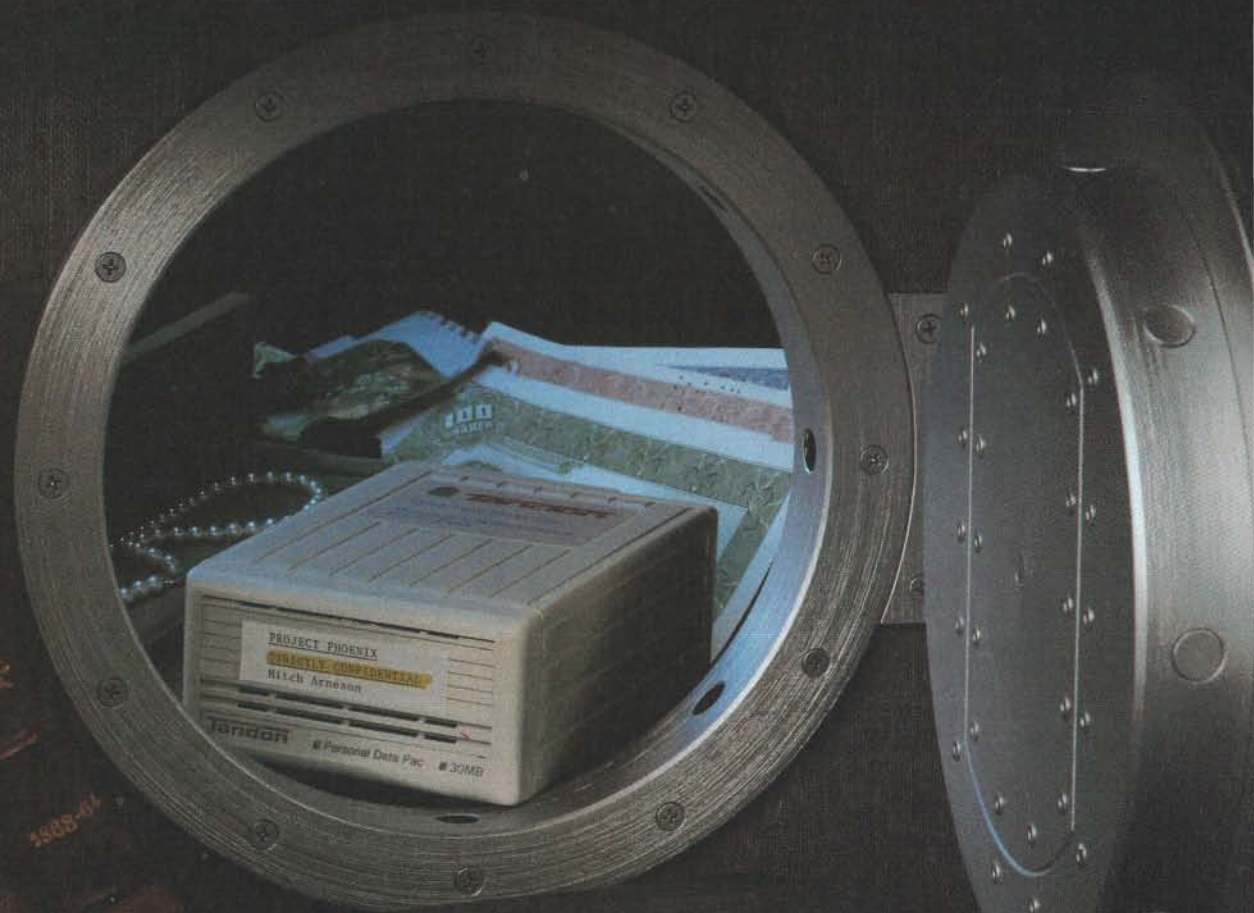

PC
MAGAZINE
EDITOR'S
CHOICE

"Secure"

si·kūr,' a. [L. securus]: *The ability to shelter your confidential data and your whole personal computing environment away from prying eyes, meddling associates and criminal intent.*

Securing your personal computer files has been, until now, a mostly complicated and unreliable matter. Not any more.

As incredible as it may sound, now there is a simple and economical way to solve all your data security problems. It's called Personal Data Pac technology. From Tandon.

This innovative technology consists of a portable, small and rugged 30MB Winchester disk pack, the Personal Data Pac, and an external drive receptacle, the Ad-PAC. The total package costs less than \$1000.

When you equip your PC with our Personal Data Pac technology, data safety and security problems become a thing of the past. Instantly. You simply eject the Personal Data Pac, containing all your data files, and lock it away in your desk or your safe.

Installation of the Ad-PAC is as simple as plugging the controller card into an expansion slot of any AT-compatible workstation and connecting the cable. The Personal Data Pac can then be inserted and removed as easily as a VCR cassette.

But removability doesn't mean loss of reliability or efficiency. The Personal Data Pac performs exactly like a fixed Winchester with an effective access time of 40 milliseconds. According to recent

tests, this represents the fastest data throughput of any removable mass storage available today.

The Tandon Ad-PAC will also secure you from the disasters of fixed disk failure and at the same time eliminate the need for inconvenient

and slow back-up systems. A full 30MB of programs and files can be transferred from Data Pac to Data Pac in less than three minutes. So when disaster strikes, insert the back-up Data Pac and it's business as before.

Tandon's simple solution to the complexities of data security is also available in a complete and powerful system, the Tandon Pac 286. This compact, fully AT-compatible

workstation offers high-performance computing and the increased versatility, capacity and convenience of two built-in Data Pac receptacles.

So, don't call a high-priced security consultant. See your local Tandon dealer for a more sensible solution, or call us at **1-800-556-1234**, Ext. 171 (in California **1-800-441-2345**, Ext. 171).



The Tandon Ad-PAC

Tandon

*We're redefining
personal computing.*

GSA# GSOOK87AGS6049 OPT1

Pricing and information correct at presstime. Tandon reserves the right to vary prices and specifications at any time without notice. Tandon is a trademark of Tandon Corporation.

Circle 326 on Reader Service Card (DEALERS: 327)



CTX

Presents

14" VGA MONITOR
CTX-2431

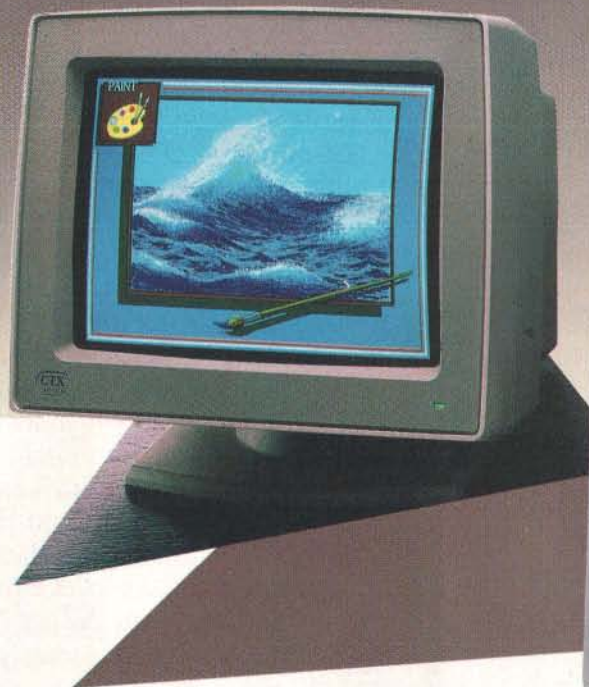

14" MULTISCAN COLOR MONITOR
CTX-3435



CTX, already rated "Best Buy" by PC Digest and PC World for their multiscan and monochrome monitors, now presents its NEW 14" Multiscan and VGA monitors.

The new CTX-3435 Multiscan monitor features a 14" diagonal non-glare CRT. The unit rests on a newly developed detachable swivel-tilt base designed for greater versatility and convenience. This monitor's wide range of compatibility includes Apple MacII and Commodore Amiga as well as CGA, EGA, MDA, and VGA video cards.

The new VGA monitor, with its 30 MHz band width, is compatible with all VGA cards on the market today. Availability is in both monochrome and color, each offering resolutions of 720x480, 720x400, or 720x350.

For more information on these new CTX monitors and other high quality CTX products please contact our new headquarters at:

CTX INTERNATIONAL, INC.

161 Commerce Way
Walnut, CA 91789

TEL: (714) 595-6146 • FAX: (714) 595-6293

EASTERN REGIONAL OFFICE

CONTINENTAL TECHNOLOGY, INC.

300 McGAW DRIVE
EDISON, NEW JERSEY 08837

TEL: (201) 225-7377 FAX: (201) 225-6355

FACTORY

CHUNTEX ELECTRONIC CO., LTD.

ROOM 401, NO. 50 SEC. 1,
HSIN-SHENG S. RD.,
TAIPEI, TAIWAN, R.O.C.

TEL: (02) 3921171 FAX: (02) 3919780

*Apple MacII is a registered trademark of Apple Computer, Inc.
Amiga is a registered trademark of Commodore-Amiga.*

MULTIPLE REGRESSION WITH EXCEL

A little-known feature of Microsoft Excel lets you do powerful multiple regression analysis

Charles W. Kyd

Microsoft Excel contains a powerful feature that's new to spreadsheet technology. It's also a hidden feature, largely overlooked by users and the computer press.

The new feature is array processing within spreadsheet formulas. It includes functions that multiply, invert, transpose, and find the determinant of arrays or matrices. It lets you generate a temporary array, modify it, and summarize it, all within the same formula. It allows range definitions to change as the result of calculated values in the spreadsheet. It even brings certain characteristics of a relational database to spreadsheets.

Most important, it lets you perform sophisticated applications, such as multiple regression analysis.

Array Processing in Excel

In Excel, an array is a rectangular area of data that can exist in spreadsheet cells, in range definitions, or as a temporary work area within a formula. By using arrays, you can largely eliminate the columns of intermediate calculations that clutter many spreadsheets.

For example, figure 1 presents a simple purchase history file containing the month of purchase, part number, quantity, and price of each purchased item. To calculate total purchases for this figure, most spreadsheets would require that you create a column that subtotals purchases for each row. Figure 2, however, summarizes figure 1 directly.

To create the formulas in figure 2, you first define in figure 1 the range name *Quantity* as `=C6:C14` and *Price* as `=D6:D14`. So far, there are no surprises; you could define similar ranges in most other spreadsheets. But in Excel, you can also define the range name *Subtotals* as `=Quantity*Price`. This definition sets up *Subtotals* as an array that consists of each cell of the *Quantity* array multiplied by the corresponding cell of the *Price* array.

Notice that, unlike other spreadsheets, Excel allows the new array to exist in memory, independent of the rows and columns

in the spreadsheet. To prove this point, if you press the F5 (GOTO) key in PC Excel and enter *Subtotals*, Excel returns an error message because there's no place within the spreadsheet for the cell pointer to go.

The formula in cell E21 of figure 2, which depends on Excel's array-processing ability to return the amount of total purchases, could be replaced with a different formula:

1. It could contain `=SUM(Subtotals)`. Because you've defined *Subtotals* as an array that contains the subtotal of each purchase, you can simply find the sum of this array.

2. It could contain `=SUM(Quantity*Price)`. When you enter this formula, it first creates a temporary array containing each subtotal, which the *SUM* function totals. For this formula to work properly, however, you must enter it as an array formula. To do so, first type it in as you normally would. Then, in PC Excel, hold down Control-Shift and press Enter. (In Mac Excel, hold down the Command key and press Enter.) When you do so, the spreadsheet shows that you've created an array formula by enclosing it in braces in the formula bar, like this: `{=SUM(Quantity*Price)}`.

3. It could contain `=MMULT(TRANSPOSE(Quantity),Price)`. Using the techniques of traditional matrix algebra, this formula calculates the dot product of the two arrays. To do so, the formula transposes the 4-by-1 *Quantity* array to produce a 1-by-4 array, and then premultiplies it by the 4-by-1 *Price* array, producing a 1-by-1 array that contains the grand total.

These formulas generate the same result, and they do so more quickly and with a less-cluttered worksheet than other spreadsheet programs require. But because of the way you've defined the *Quantity* and *Price* ranges, all three of the formulas rest on shaky ground. Remember, these ranges begin and end with data in figure 1, not with the top and bottom borders. This approach is dangerous because if you insert additional rows of data above the first row or below the last row of data, you don't expand the two ranges as you should to include the new data.

continued

The common way to deal with this problem is to define range names to include the top and bottom borders. This way, range names always include any rows of data inserted between the borders. Unfortunately, this approach fails in this instance because many array operations would attempt to treat the empty border cells as legitimate data, thereby returning error messages.

To solve this problem, you must define dynamic range names, names that expand or contract as the shape of the data expands or contracts. To do so, you first define the range Input as `=A$5:$D$15`. This range, which surrounds the data in figure 1, serves as a reference for the dynamic range name definitions.

Once you've defined Input, you can define these four ranges:

```
Month=INDEX(Input,2,1):INDEX(Input,ROWS
(Input)-1,1)
PartNum=INDEX(Input,2,2):INDEX(Input,ROWS
(Input)-1,2)
Quantity=INDEX(Input,2,3):INDEX(Input,ROWS
(Input)-1,3)
Price=INDEX(Input,2,4):INDEX(Input,ROWS
(Input)-1,4)
```

These dynamic-range definitions allow the number of rows of data to expand and contract while allowing the defined ranges to do likewise and still reference only the actual data. The INDEX function provides the key to this process. This function takes the form `=INDEX(array, row_num, column_num)` and returns either data or a cell reference, depending on how it's used in a formula. Here, because two INDEX functions are joined by a colon, Excel correctly assumes that you want it to return a cell reference.

Therefore, the first cell in the Quantity range is defined by

the cell in the second row and third column of the Input range, which is cell C6. The last cell in the Quantity range is defined as one row above the last row of the Input range and in the third column of that range, which is cell C14. (The ROWS function returns the number of rows in a range and therefore specifies the last row of the Input range.)

This approach, therefore, defines Quantity as the range C6:C14. This is the same area that the original definition of Quantity specified, but unlike the first definition, this one is dynamic.

With these four ranges defined, you can quickly calculate the remaining summary information in figure 2. Cell E22 in this figure counts the number of purchases made in February. Its formula, which you must enter in the form of an array, is as follows:

```
=COUNT(IF(Month=2,Month))
```

This formula creates a temporary array that contains the month value whenever the value equals 2, and then the formula returns the count of this array.

Alternatively, you could use the following formula to produce the same result:

```
=SUM(IF(Month=2,1))
```

This formula creates a temporary array that contains the value of 1 whenever a value in the Month range equals 2; the sum of this array returns a count of the number of occurrences.

Cell E23 returns the sum of all purchases made in February for part number 110. Its formula, which must also be entered as an array, is

```
=SUM(IF(PartNum=110,IF(Month=2,Subtotals)))
```

continued

	A	B	C	D	E
1					
2					
3	Purchase History File				
4	Month	PartNum	Quantity	Price	
5					
6	1	101	12	3.00	
7	1	105	50	41.00	
8	1	105	20	42.30	
9	2	101	100	2.95	
10	2	110	10	18.00	
11	2	105	10	40.85	
12	2	101	100	3.10	
13	3	110	50	18.00	
14	3	112	5	7.50	
15					
16					

Figure 1: This purchase history file contains transaction data that Excel's array formulas summarize in figure 2.

This formula creates a temporary array that contains a subtotal value whenever the month of a purchase equals 2 and the part number equals 110, and then the formula returns the sum of these subtotals.

Notice that instead of the AND operator, this formula uses nested IF statements to join the two conditions. (PC Excel allows a maximum of eight IF statements to be nested in this manner; Mac Excel allows seven.) Also notice that only the final IF statement in the nest must specify the THEN portion of the argument.

The table at the bottom of figure 2 uses a similar formula to generate a summary of purchases by part number and month. The general format of this table is one that I've used for years for analyzing purchases, sales, operating expenses, and other transaction data.

To generate this table using most other spreadsheets, you would need to define a Criteria range and then set up a two-way data table that depends on a DSUM calculation. Not only does this approach require a complex setup, it calculates slowly because the entire spreadsheet must recalculate once for every cell in the data table.

However, Excel lets you create this table easily. To do so, first enter the data in the ranges A29:A32 and B27:D27, and then enter the following array formula in cell B29:

```
=SUM(IF(PartNum=$A29,IF(Month=B$27,Subtotals)))
```

To complete the table, simply copy the formula in cell B29 to the range B29:D32, and then enter the SUM formulas in row 34 and in the range E29:E32. Using this approach to generate the summary table requires that the spreadsheet recalculate only once—just as with any other formula that does not require iteration.

Multiple Regression Analysis with Arrays

One effective way to illustrate the power of array processing is to apply it to a challenging but useful application, such as multiple regression analysis. This statistical technique offers three challenges: It depends on sophisticated formulas generally hidden in dusty statistics books; it uses calculations that are beyond the ability of most spreadsheets to directly perform; and it produces results that many users find difficult to interpret.

Nevertheless, multiple regression serves as a valuable tool in many business applications. Suppose, for example, that the controller of a company that manufactures printed circuit boards for personal computers wants to improve her company's sales forecasts. To bring a note of reality to the overenthusiastic estimates of her marketing department, she decides to forecast company sales by using general economic indicators. If she can find a relationship between the economic indicators and her sales, she can base her own forecasts on the economic forecasts of outside experts.

Multiple regression analysis is a standard statistical technique that can find this relationship between a dependent variable (sales) and several independent variables (economic indicators). To begin the analysis, the controller decides to test an assumption that her sales vary with changes in total corporate profits, disposable consumer income, and the nationwide sales of personal computers. She therefore assembles the data shown in figure 3.

Figure 4 shows a spreadsheet that contains the results of her analysis. These are the statistics commonly produced by software designed for statistical analysis, but not by spreadsheet programs. (The Data Regression command in Lotus 1-2-3 generates about half of these statistics—those found in rows 7, 9, 10, and 19, in the range C20:E20, and in cell A21.)

continued

	A	B	C	D	E	F
18						
19						
20	Purchase Summary					
21	Total Purchases				5,063.00	
22	Number of Purchases In February					4
23	Sum of February Purchases for Part # 110				180.00	
24						
25	Summary by Part Number by Month					
26		Month				
27	PartNum	1	2	3	Total	
28						
29	101	36.00	605.00	0.00	641.00	
30	105	2,896.00	408.50	0.00	3,304.50	
31	110	0.00	180.00	900.00	1,080.00	
32	112	0.00	0.00	37.50	37.50	
33						
34	Total	2,932.00	1,193.50	937.50	5,063.00	
35						

Figure 2: Array formulas in this figure summarize the transaction data from figure 1. They do so without using columns of intermediate calculations, criteria ranges, DSUM functions, or data tables.

CompuServe Now Available
at **Radio Shack**



Lose Those Lonesome IBM Blues.

The largest group of IBM® and compatible PC users in the world shares its problems and solutions online every day in CompuServe's IBM Forums. And you can join them.

Keep up with the latest upgrades as soon as they're available. Get help with printer and disk utilities from experienced users. Plus support from IBM software authors and hardware vendors.

Why spend hours working the bugs out of a program when somebody has already solved the

problem? How will OS/2 and Windows affect you? Visit a CompuServe IBM Forum and find out. There's no better way to get more out of your IBM or compatible.

To join CompuServe, see your computer dealer. To order direct or for more information, call 1 800 848-8199. In Ohio and Canada, call 1 614 457-0802. If you're already a member, type GO IBMNET at any ! prompt.

CompuServe®

An H&R Block Company

The correlation matrix helps uncover a potential problem; the forecast may be unreliable if two or more independent variables are closely correlated.

To cut to the heart of the application, I've included tables that explain both the range names (see table 1) and formulas (see table 2) used in figure 4. This approach lets you refer to the information easily when you create the application. But before you refer to these formulas, let's take a closer look at what their results mean.

Interpreting the Results

How might the corporate controller interpret the results in figure 4? Overall, the analysis shows a strong association between changes in sales and changes in the economic indicators that she's selected. The R-squared value in cell C10 is the easiest value to interpret. It tells the controller that 90.1 percent of the variations in sales can be explained by variations in the independent variables.

When the controller looks up the F value (cell C11) in a table at the back of nearly any introductory statistics book, she learns that she's identified a statistically significant relationship in her analysis. When she checks the standard error of the estimate (cell C9), she learns that actual sales generally fall within

\$922 of their estimated value. This value represents a relatively accurate estimate, considering that her sales range from \$10 to \$17 in figure 3.

Row 19 of figure 4 shows the regression formula, which estimates that monthly sales equal \$48.646, plus 0.704 times corporate profits in the month, plus 0.318 times disposable income, plus 0.714 times computer sales. Rows 20 and 21 help her evaluate the significance of these coefficients. Row 20 contains a measure of variability of each coefficient, and row 21 contains a ratio that shows how many times greater each coefficient is than its measure of variability. When she looks up each of these t-statistics ratios in her statistics book, she finds that each coefficient is significant at the 95 percent confidence level.

Rows 28 and 29 help the controller to estimate future sales. She enters economic forecasts of corporate profits, disposable income, and computer sales in row 28. When she recalculates the spreadsheet, it combines the coefficients in row 19 and the estimates in row 28. The result, which appears in cell B29, predicts the sales of her own printed circuit boards.

continued

	A	B	C	D	E	F
1						
2						
3	Data for Multiple Regression Analysis					
4			Corp Profits	Disposable Income	Computer Sales	Board Sales
5			1	2	3	Y
6	Month					
7						
8	January	1	35	49	33	17
9	February	1	30	48	30	10
10	March	1	34	50	32	14
11	April	1	35	50	28	12
12	May	1	34	51	29	12
13	June	1	39	49	30	16
14	July	1	34	55	33	16
15	August	1	36	47	33	14
16	September	1	35	50	31	14
17	October	1	34	47	31	12
18	November	1	36	50	34	17
19	December	1	31	49	31	10
20						

Figure 3: A record of economic data by month and a record of printed circuit board sales for a hypothetical company. Figure 4 performs a multiple regression analysis of this data.

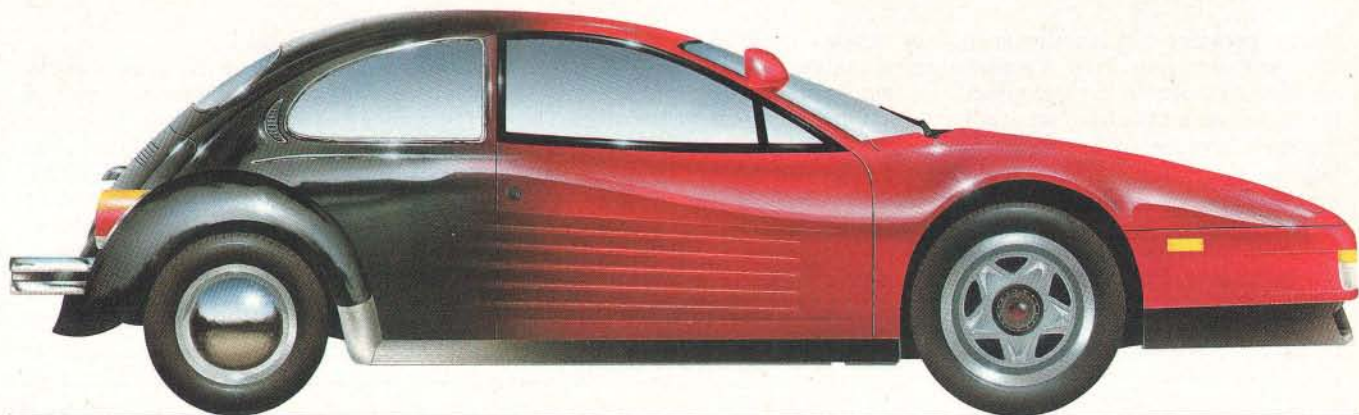

Where price and performance meet.

Life is one long—usually frustrating—search for the highest possible performance at the best possible price.

Fortunately, for FCC-approved XT[®], AT[®] and 386* bare-bone systems, as well as a full line of motherboards and add-on cards, your search is over. You've found DTK.

DTK's high-performance boards collectively enjoy a reliability rate of 99.5%. Because they're manufactured to exacting quality control standards, then individually burned-in for 24 hours.

Which is why DTK products are exceptionally popular. This 10 MHz XT motherboard, for example, already has over 200,000 satisfied customers worldwide. And it's just one of our success stories.

Contact the DTK office nearest you. We'll send you information on our full line of quality computer boards and systems. And show you how affordable the price of high performance can be.

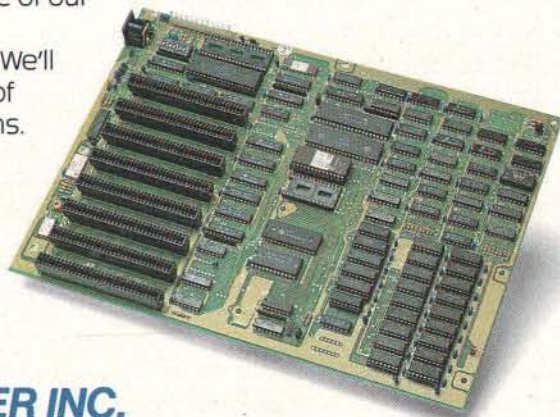

"See us at Comdex Fall 1988
Bally's B412



DTK COMPUTER INC.

15711 E. Valley Blvd. • City of Industry, CA 91744
Tel: (818) 333-7533 • Fax: (818) 333-5429

DTK Computer Inc. of Florida
7245 Corporate Center Dr., Suite B
Miami, FL 33126
Tel. (305) 477-7440
Fax: (305) 477-8322

DTK Computer Inc. of New Jersey
300 Columbus Circle, Raritan Center
Edison, NJ 08818
Tel. (201) 417-0300
Fax: (201) 417-0307

DTK Computer Inc. of Texas
10535 Wilcrest Dr., Suite 120
Houston, TX 77099
Tel: (713) 568-6688
Fax: (713) 568-5688

DTK Computer GmbH
Wahlerstr 16
4000 Dusseldorf 30
West Germany
Tel: 011-49-221-656031
Fax: 011-49-221-653753

EXCLUSIVE DISTRIBUTORS:
Florida: TWC (305) 599-0871
Northern California: Supercom
(408) 772-9393

XT and AT are registered trademarks of International Business Machines Corporation. DTK is a registered trademark of Datatech Enterprises Co., Ltd. *FCC Class A approval

FEATURE
MULTIPLE REGRESSION WITH EXCEL

The spreadsheet includes an analysis of variance (ANOVA) table for two reasons. First, it generates certain values required by other formulas in the spreadsheet. Second, it summarizes the regression results from yet another viewpoint. You can see that the sum of the squares due to regression (SSR) is almost as large as the total sum of squares (SST). In fact, as the R-squared value tells you, the SSR represents 90.1 percent of the SST. Similarly, the mean sum of squares due to regression (MSR) is significantly greater than the mean sum of squares due to the error (MSE). In fact, as the F value tells you, the

MSR value is 24.28 times the MSE value.

The correlation matrix at the bottom of the spreadsheet in figure 4 displays the correlation coefficients for each pair of variables. This coefficient is a measure of the linear association between each pair. If the variables have a perfect linear relationship, the correlation coefficient equals either 1 or -1, depending on whether the variables both rise and fall together or whether one rises as the other falls. (Of course, each variable in the matrix is perfectly correlated with itself.) The correlation

continued

	A	B	C	D	E	F	G
1							
2							
3	Multiple Regression Analysis						
4							
5							
6	Regression Results						
7	Number of Observations (n)		12				
8	Number of Ind. Variables (k)		3				
9	Std Error of Estimate		.922				
10	R-Squared		90.10%				
11	F Value (df= 3,8)		24.28				
12							
13							
14	Variable Number		1	2	3	Y	
15							
16							
17	Individual Variables						
18		Constant					
19	Coefficients	-48.646	.704	.318	.714		
20	Std Error of Coef	8.471	.121	.132	.156		
21	T Statistic (df=8)	-5.742	5.803	2.398	4.594		
22							
23	Average Value		34.417	49.583	31.250	13.667	
24	Standard Deviation		2.314	2.109	1.815	2.498	
25							
26							
27	Point Estimate						
28	Enter Values:		35	49	33		
29	Est. Y Value	15.142					
30							
31							
32	Analysis of Variance (ANOVA)						
33		SS	df		MS		
34	Regression	SSR	61.87	3	20.62	MSR	
35	Error	SSE	6.80	8	0.85	MSE	
36	Total	SST	68.67	11			
37							
38							
39	Correlation Matrix						
40		1	2	3	Y		
41	1	1.0000	.0202	.1461	.7337		
42	2	.0202	1.0000	.1009	.3336		
43	3	.1461	.1009	1.0000	.6414		
44	Y	.7337	.3336	.6414	1.0000		
45							
46							
47							

Figure 4: This spreadsheet uses Excel's array processing abilities to present the statistics common to statistical software.

MULTIPLE REGRESSION WITH EXCEL

Table 1: The range names used to create the spreadsheet in figure 4.

Input=MR_DATA.XLS!Input
This range name refers to figure 3.

**Data=INDEX(Input,2,2):
INDEX(Input,ROWS(Input) - 1,COLUMNS(Input))**
The Data matrix contains all the data and only the data. It excludes borders and the column of 1s from the Input matrix.

**Xi=INDEX(Input,2,1):
INDEX(Input,ROWS(Input) - 1, COLUMNS(Input) - 1)**

**X=INDEX(Input,2,2):
INDEX(Input,ROWS(Input) - 1, COLUMNS(Input) - 1)**
These two arrays of X data differ in only one way: The Xi matrix includes the column of 1s; the X matrix excludes this column.

**Y=INDEX(Input,2,COLUMNS(Input)):
INDEX(Input, ROWS(Input) - 1,COLUMNS(Input))**
The Y column contains the data in the rightmost column of the Data matrix.

These four ranges are defined using dynamic range definitions, as described in the text.

n=\$C\$7
This name defines the cell that contains the number of observations (in this example, the number of months of data).

k=\$C\$8
Authorities are divided between whether the k notation should represent the number of independent variables—the Xs—or the number of all variables—the Xs and the Y. Here, k represents the number of X variables.

b=\$B\$19:\$E\$19
This name contains all coefficients of the regression equation.

**Avg=\$C\$23:\$F\$23
AvgY=\$F\$23**
The Avg name contains the averages of the X and Y variables. The AvgY range contains only the average for the Y variable.

Std=\$C\$24:\$F\$24
This name contains the standard deviation of each of the X and Y variables.

Est=\$B\$28:\$E\$28
The Point Estimate section of figure 4 forecasts a value of Y when you enter estimated values of X. This range contains the estimated values of X. Notice, however, that the range includes cell B28, which contains the hidden value of 1. To hide this value, select Format Number and then enter ";" (two semicolons) as a custom format.

**SSR=\$C\$34
SSE=\$C\$35
SST=\$C\$36**
These names contain the respective values for the sum of the squares due to regression (SSR), attributed to errors (SSE), and the total sum of squares (SST).

**MSR=\$E\$34
MSE=\$E\$35**
These two names label values from the ANOVA table. MSR represents the regression mean square; MSE represents the error mean square.

AMX 86

**KADAK's
engineers bring
years of practical real-time
experience to this mature**

MULTI-TASKING SYSTEM (version 2.0)

for the IBM® PC, PC/XT and PC/AT

- No royalties
- IBM PC DOS® support
- C language support
- Preemptive scheduler
- Time slicing available
- Source code of the C interface and device drivers is included
- Intertask message passing
- Dynamic operations:
 - task create/delete
 - task priorities
 - memory allocation
- Event Manager
- Semaphore Manager

AMX86™ operates on any 8086/88, 80186/88, 80286 system.

Demo package \$25 US
Manual only \$75 US
AMX86 system \$2195 US
(shipping/handling extra)

KADAK Products Ltd.

206-1847 W. Broadway
Vancouver, B.C., Canada
V6J 1Y5



Telephone: (604) 734-2796
Telex: 04-55670

Also available for 8080, Z80, 68000

A MESSAGE TO OUR SUBSCRIBERS

FROM TIME TO TIME WE MAKE THE BYTE subscriber list available to other companies who wish to send our subscribers material about their products. We take great care to screen these companies, choosing only those who are reputable, and whose products, services, or information we feel would be of interest to you. Direct mail is an efficient medium for presenting the latest personal computer goods and services to our subscribers.

Many BYTE subscribers appreciate this controlled use of our mailing list, and look forward to finding information of interest to them in the mail. Used are our subscribers' names and addresses only (no other information we may have is ever given).

While we believe the distribution of this information is of benefit to our subscribers, we firmly respect the wishes of any subscriber who does not want to receive such promotional literature. Should you wish to restrict the use of your name, simply send your request to the following address.

BYTE MAGAZINE

ATTN: SUBSCRIBER SERVICE

P.O. Box 7643

TEANECK, NJ 07666-9866



Table 2: *The formulas used to create the spreadsheet in figure 4. They should be entered in the order they're listed here.*

C7=COUNT(Y)

The number of Y values equals the total number of observations.

C8=COLUMNS(X)

The number of X columns equals the number of independent variables, range name k.

A11="F Value (df= "&k&","&n - k - 1&")"

This formula returns the two values of F's degrees of freedom (k and n - k - 1) as a label.

C14 1

D14=1+C14

Copy this formula to the right as needed.

B19(PC)=INDEX(LINEST(Y,X),1,k - B14 + 1)

In PC Excel, the LINEST function returns a 1-by-4 array that contains the coefficients of a multiple regression equation in the order of X3, X2, X1, and the constant. The INDEX function displays a value from this array. Copy this formula to the right as needed.

B19(Mac)=INDEX(MMULT(MMULT(MINVERSE(MMULT (TRANPOSE(XI),XI)), TRANPOSE(XI)), Y),B14 + 1,1)

Because Mac Excel (through version 1.5) doesn't have the LINEST function, you must use arrays to generate the coefficients of the multiple regression equation. This array formula returns the coefficients in a 4-by-1 array in the order of the constant, X1, X2, and X3, and then the INDEX function displays the appropriate value. Copy this formula to the right as needed.

A21="T Statistic (df= "&n - k - 1&")"

This formula returns the value of the t-statistic's degrees of freedom (n - k - 1) as a label.

C23=AVERAGE(INDEX(Data,1,C\$14): INDEX(Data,ROWS(Data),C\$14))

C24=STDEV(INDEX(Data,1,C\$14): INDEX(Data,ROWS(Data),C\$14))

Copy these formulas to the right as needed. However, because the Y column contains a Y in row 14 rather than a number, this formula won't work for the Y values.

F23=AVERAGE(INDEX(Data,1,COLUMNS(Data)): INDEX(Data,ROWS(Data),COLUMNS(Data)))

F24=STDEV(INDEX(Data,1,COLUMNS(Data)): INDEX(Data,ROWS(Data),COLUMNS(Data)))

Use these two formulas to calculate the average and standard deviation of the Y value.

B28 1

This cell contains the value of 1 but is hidden by its number format ";;".

C28 35

The remaining cells in this row contain the forecasted values for the independent variables (the X values).

B29=MMULT(Est,TRANPOSE(b))

This array formula calculates the Y value by multiplying the estimated values of the independent variables by the coefficients of the regression equation.

C34=SUM((AvgY - MMULT(XI,TRANPOSE(b)))^2)

To find the sum of the squared deviations due to regression

(SSR) in this array formula, subtract the column of predicted Ys (generated here by the MMULT section of the formula) from the mean of the Ys (AvgY), square the results, and then sum the squares.

C35=SUM((Y - MMULT(XI,TRANPOSE(b)))^2)

To find the sum of the squared deviations caused by errors (SSE) in this array formula, subtract the column of predicted Ys (generated here by the MMULT section of the formula) from each value of Y, square the results, and then sum the squares.

C36=SUM((Y - AvgY)^2)

To find the total sum of the squared deviations (SST) in this array formula, subtract the average Y from each value of Y, square the results, and then sum the squares.

D34=k

The SSR degrees of freedom equals the number of independent variables.

D35=n - k - 1

The SSE degrees of freedom equals the total number of observations less the number of both the dependent and independent variables.

D36=n - 1

The SST degrees of freedom equals the total number of observations less the number of dependent variables. It also equals the sum of the previous 2 degrees of freedom.

E34=SSR/D34

The mean squared deviation due to regression (MSR) equals the sum of the squares due to regression divided by the SSR degrees of freedom.

E35=SSE/D35

The mean squared deviation caused by the error (MSE) equals the sum of the squares caused by the error divided by the SSE degrees of freedom.

A42=1 + A41

C40=1 + B40

Copy these formulas down or to the right as needed.

B41=(MMULT(TRANPOSE(Data - Avg),DataAvg)/ (TRANPOSE(Std)*Std))/(n - 1)

If you let U and W be any variables in the Data range, and you let u and w equal the value of the deviations from their means, their correlation coefficient is equal to $\text{Sum}(u \cdot w) / \sqrt{\text{Sum}(u^2) \cdot \text{Sum}(w^2)}$. This formula generates an array that contains all such combinations of correlations. To enter this formula, first highlight the range B41:E44, type the formula as shown, and then enter it by pressing Control-Shift and Enter. (In Mac Excel, hold down the Command key and then press Enter.)

C9=(SSE/(n - k - 1))^0.5

The standard error of the estimate equals the standard deviation of the error values. To find the standard deviation, divide the sum of the squares of the error terms by (n - k - 1) and then take the square root of the result.

C10=SSR/SST

The R-squared represents the proportion of all squared deviations that have been explained by the regression equation. That is, it's the simple ratio shown.

continued

C11 = MSR/MSE

The F value compares the mean sum from regression to the mean sum from errors.

B20 = SQRT(INDEX(MINVERSE(MMULT(TRANPOSE(X1), B\$14+1, B\$14+1)*\$C\$9^2)

Multiplying the MINVERSE portion of this array formula by the square of the standard error of the estimate ("sigma squared") returns the variance-covariance matrix. Taking the square roots of the diagonal elements of this matrix returns the standard deviations of each of the coefficients of the regression equation, which are more commonly referred to as the standard errors of the coefficients. When you've entered this formula in the one cell shown, copy it to the right as necessary.

C21 = C19/C20

The t-statistic equals each coefficient divided by its standard error.

coefficient equals 0 if there is no linear relationship between the variables.

This correlation matrix helps the controller uncover a potential problem with her regression analysis: Her forecast may be unreliable if two or more independent variables are closely correlated, a condition that statisticians call *multicollinearity*. In the spreadsheet, however, the correlation matrix shows that none of the independent variables have a correlation coefficient greater than 0.1461. Therefore, multicollinearity isn't a problem for her because, as a rule of thumb, these problems arise only when correlation coefficients are greater than 0.70 or less than -0.70.

Suppose, however, that the controller had included two additional independent variables in her analysis: sales of monitors for personal computers, and corporate bankruptcies. If she had, she probably would have found that sales of personal computers show a high and positive correlation with the sales of monitors for personal computers and that business profits show a high and negative correlation with corporate bankruptcies (as profits go up, bankruptcies go down). She would therefore eliminate these variables, for two reasons. From a statistical standpoint, they create multicollinearity problems. From a practical standpoint, these two variables add little to the analysis, and there is no need to go to the work and expense of including them.

Creating the Worksheet

To create figure 3, first open a new worksheet. Turn off its gridlines and set the manual calculation mode. This figure contains no formulas. Enter the labels, data, and formatting as shown. Notice that column B contains a column of 1s. The matrix formulas used in figure 4 won't work properly if this column is missing. If you want to hide this column after you've entered it, do so by assigning the number format ";;;" to the column.

The current version of Mac Excel (1.5) cannot draw the shaded borders in figure 3. Instead, I suggest Mac Excel users substitute a row of Xs for the shading. To do so, highlight the shaded area, select Format Alignment, choose Fill, and then enter X in the leftmost cell.

Define the range Input as =\$B\$7:\$F\$20. This range extends

from the borders above and below the data and from the column of 1s to the last column of data. After you've assigned the range name, save your spreadsheet using the name MR_DATA.XLS.

To create figure 4, first open a new worksheet and turn off its gridlines. Enter all labels and borders shown in the figure before entering its names and formulas. Enter all range-name definitions shown in table 1 for the figure. Of course, many of these ranges have no values associated with them yet, but this will cause no problem.

I've arranged the spreadsheet in figure 4 in a logical sequence for reading the results of a regression analysis, not in a sequence convenient for entering the formulas. Table 2 shows the sequence to follow when you enter the figure's formulas. When you follow this sequence, each formula you enter builds on formulas entered previously.

Cell B19 of figure 4 contains the only instance where the Mac and PC versions of Excel use different formulas. As table 2 shows for this cell, the PC version uses the LINEST function, which returns the coefficients of a multiple regression equation. But because the current version of Mac Excel lacks this function, you must substitute an array formula. Using matrix notation, this formula is as follows:

$$b = (X1'X1)^{-1} X1'Y$$

In this formula, b is the 4-by-1 array of the coefficients of a multiple regression equation, X1 and Y are ranges defined in table 1, the apostrophe means to transpose the array, and ⁻¹ means to find the inverse of the array.

When you've completed figure 4, save it using the name MR_3. This name stands for multiple regression using three independent variables.

Roll Your Own

To enter your own data into figure 3, you will probably need to modify its size. When you do, be sure to adjust both figures 3 and 4, if necessary, so each has the same number of independent variables.

When you adjust figure 4, the correlation matrix will give you a problem initially, because when you try to add rows or columns to the matrix, you get an error message that says "Can't change part of an array." To work around this problem, highlight the matrix, click on the formula in the formula bar, and press Control-Enter (Option-Enter in Mac Excel). The correlation matrix will then return a #VALUE! error. Insert the additional row and column and add the new headings.

To change the error values into a working matrix, highlight the matrix that now contains five rows and columns, click on the formula in the formula bar, and press Control-Enter (Command-Enter in Mac Excel).

When you recalculate, the matrix should return the correct values. But if it still returns a #VALUE! error, check that all numbered headings are correct and that you have five columns of data in your version of figure 3.

When you first try to create and modify figures 3 and 4, you'll probably see that #VALUE! error more than once—I certainly did. But as you use arrays, you'll quickly learn that they're easy to use and correct. Soon, you'll wonder how you ever got along without their incredible power. ■

Charles W. Kyd spent 10 years as a chief financial officer of high-tech companies, and he is now a writer and consultant. This article has been adapted from his new book, The Microsoft Excel Business Sourcebook (Microsoft Press, 1988). He can be reached on BIX c/o "editors."

2500 WEST COUNTY ROAD 42 • #5 • BURNSVILLE, MN 55337 • (612) 894-0595

A Small Case For BIG Performance!!!

TOSHIBA



CALL
T1000
T1200F
T1200H
T3100
T3200
T5100

CALL

ZENITH

SUPERSPORT



Dual Floppy
CALL
20 MB HD
CALL
SUPERSPORT
286/20
CALL

mitsubishi



New!

MP286L/20

- 11" Diagonal Black & White Display
- 20 MB Hard Disk
- 12 MHz 80286
- 1.4 MB Floppy Drive

Introductory Price

\$2695.00

Dual Floppy (1.4 MB) Model

\$2195.00

New!

From MegaHertz

Easy Talk 3270

3270 Emulation Card for Toshiba Laptops; Fully supports IRMA & IBM Emulation. Auto-Config. - No Jumper Changes required. Includes software for 3270 and IND/FILE Transfer Support

\$599.00

Easy EGA

EGA Card for Toshiba T1200 and T3100 Laptops. Supports MDA, HGC, CGA & EGA

\$299.00

Easy Talk E2400

2400 Baud Modem for the Epson Equity LT

\$239.00

Weltec . . .

External 5.25" FDD

\$199

Specify TOSHIBA, ZENITH or NEC*

**No cable w/NEC Drive - Cable included in NEC Laptop Box*

MHz INTERNAL MODEMS

1200 Baud \$139 2400 Baud \$239

Specify:

Toshiba, NEC EL/HD,
Zenith 181/183 or SupersPort

WonUnder

Single card expansion slot for **\$299**
the T1100+, T1200, T3100/20 & T5100

Diconix 150P Portable Printer **\$299**
Laplink Plus **\$79**

When Purchased with any Laptop

- Competitive Price
- Corporate Volume Discounts
- Net Terms to Qualified Corporate Accounts

Prices Subject to Change Without Notice

To Order Call:

FAX Number: 894-6175

(800) 255-4012

IN MN: (612) 894-0595

IT'S APT TO WRITE

The Abstract Planning Tool is an intelligent outliner that makes logical connections from your thoughts and ideas

Peter Wayner

I

f you don't want people to fall asleep while they're reading what you've written, there's plenty of careful planning to be done before you begin writing.

Most people organize their material with either an outline or index-card system. Many different outlining programs can help you handle this part of your writing process, but generally they are not much more than word processors that let you format your material in various ways. They rarely help you sketch out your ideas in the initial writing stages.

To make outlining more natural and precise, I have developed the Abstract Planning Tool (APT), a new system for writing that borrows many techniques from programming languages and their compilers. One significant difference between APT and other outlining programs is that this system understands logical connections. This feature is unique in that it allows you to think about the relationships between your ideas.

Birth of a Notion

Instructors of beginning programmers often tell their students that writing a good program is like writing a good essay. This advice was the inspiration for creating APT. To write a good essay, you must carefully define your topic at the beginning and

group the material into small, manageable sections. You should discuss subjects only after you have introduced the ideas on which the subjects depend. Finally, you must draw everything in your material together into a single cogent treatise at the end.

Languages like Pascal were specifically designed to force the programmer to write code that follows these structural guidelines. To a large extent, they have succeeded. There has been little focus, however, on using the structure of a well-defined programming language to help arrange the ideas for writing any type of material that requires logical organization.

Just as programmers aim to teach the machine a task, you begin a writing project by wanting to impart some information to the reader. The subject might be how Shakespeare drew heavily on the social and political tenor of Elizabethan England or how two numbers are relatively prime if, and only if, Euclid's algorithm returns a 1.

With this goal in mind, then, you outline your ideas and arrange them in a logical and reasonable order. If the outline is good, the piece will succeed and the reader will understand the topic. But if the outline is bad, the resulting material will be bad and the reader will end up confused and unsatisfied.

Unfortunately, there is no set outline pattern to require you to develop your ideas

continued

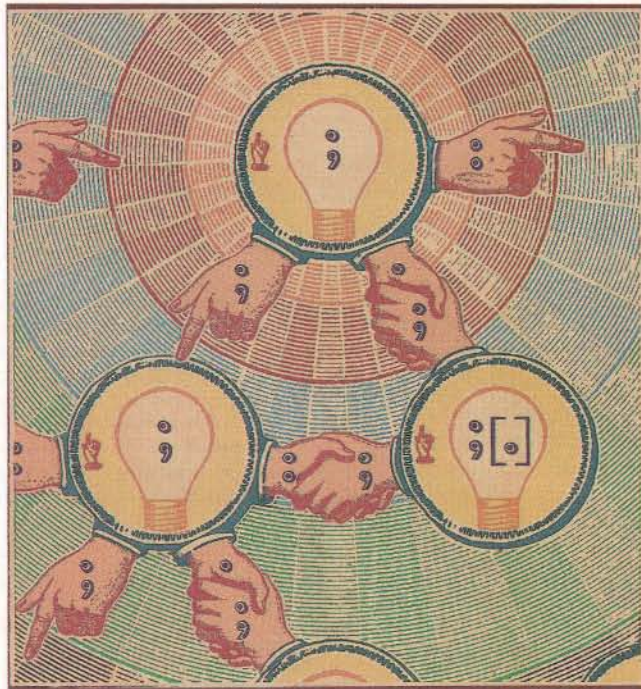

DATA RECOVERY

Successful Data Recovery:
October, 1987



Another
SUCCESS!

- Emergency data recovery
- Quality disk drive repair, sales & service
- Removable hard disk drives
- Rapid turn around time

see us at COMDEX



Rotating Memory Services

473 Sapena Court, #26
Santa Clara, CA 95054
1 (800) 333-3023
Fax (408) 988-1631

135 Marcus Boulevard
Hauppauge, NY 11788
(516) 435-2240
Fax (516) 435-8892

presenting

PADS SUPERSTATION *for* TOTAL INTEGRATION

Now you can obtain complete cradle-to-grave performance from your personal computer CAD system when performing electronic packaging design. From schematic capture to printed circuit design, to 100% completion autorouting capabilities, it's all here. We already offer the best selling PCB design software in the industry, and now you have one more reason you should be using PADS: *Total Integration*. Call our Sales Hotline today to receive a free Integrated Evaluation Package for the PADS-SUPERSTATION.

call today!

In MA: (508) 486-8929
Outside MA: (800) 255-7814

CAD
Software, Inc.
119 Russell St.
Littleton, MA 01460

carefully. Thus, when you spontaneously create an outline, you may end up with one that is hopelessly convoluted and has little or no structure. In this situation, you may overlook defining terms that need definition or you may turn lines of argument into loops by introducing facts and ideas too early or too late. As the writer, you must bear the burden and responsibility for producing a well-conceived argument.

APT is an attempt to provide writers with the power to generate structurally sound outlines by casting ideas in a quasi-mathematical or quasi-logical form. The APT compiler takes these abstractions and converts them into a simple, sound outline just as a Pascal compiler converts a list of code words into a working program. The APT compiler requires you to define all your ideas at the beginning and carefully connect them in equations. You can still produce a bad outline, just as a programmer can inadvertently generate code that will loop forever, but the structure of APT makes you think through many of the potential problems in advance.

continued

IDEAS

Slavery; {The use of slaves on southern plantations.}
Southern farming; {Economy of the South depends on large-scale plantation farming.}
Plantation labor; {Plantation farming of tobacco and sugar is labor-intensive. Automation for these processes is unavailable.}
Northern factories; {The northern economy is dominated by factories and high-technology manufacturing.}
Automation; {Automation of northern factories reduces the need for labor.}
Northern farming; {The northern soil is more suited to grains and other crops easily harvested by new automated machines.}
Economic differences; {The North has a factory economy while the South relies on labor-intensive farming.}
Tariff; {Hawley-Smoot bill raises tariffs on imported goods.}
Civil War; {War between northern and southern United States (1861-1865).}
Farming differences; {The differences between the two systems.}

CONNECTORS

helps:LEFT;
leads to:LEFT;
and;
or;
does not help;
requires:RIGHT;
different than.

CONNECTIONS

Automation helps northern farming;
Automation helps northern factories;
Automation does not help plantation labor;
Plantation labor requires slavery;
Southern farming requires plantation labor;
Tariff helps northern factories; (farming differences = northern farming different from southern farming)
Leads to economic differences; (farming differences and economic differences) leads to Civil War.

Figure 1: Using a text editor or word processor, you can create a text file to be fed into APT. The statements must be arranged under the headings *Ideas*, *Connectors*, and *Connections*.

See our all-new 24-pin printers.



Why build a printer that can print standing on its head when all you want is outstanding letter quality?

The answer is better quality printing.

We made our new 300 Series 24-pin printers more rugged than they have to be and more reliable than ever. We built in a patented optical sensor and linked it with a unique rack and pinion printhead drive.

So you get more accurate printhead positioning. And that means outstanding letter quality.

All in a printer so stable it works upside down.

But even right side up, you get letter quality printing this good.

Our engineers call this "championship specs." More than 3 million loyal users call it rugged reliability. And it shows in the quality and performance of every printer and modem we make.

Call 1-800-OKIDATA for the dealer nearest you.

Circle 239 on Reader Service Card

OKIDATA®
an OKI AMERICA company

We put business on paper

OKIDATA is a registered trademark of Oki America, Inc.
Marque déposée de Oki America, Inc.

Protects while you type!

- Remains in Place while you use your computer.
- Avoids Costly Repairs. Protects delicate electronics from dust, spills, smoke, ashes, staples.
- Soft, Flexible, retains normal keyboard feel.
- Washable, Durable High-Tech Polymer lasts years.
- Hundreds of Models. SafeSkin is available for most PCs, laptops, workstations and clone keyboards.
- Office • Home • Factory • Classroom • Laboratory

List Price \$29.95. Please call or write for free color brochure. Dealer inquiries encouraged.

SafeSkin™

Keyboard Protector

Merritt Computer Products, Inc./4561 S. Westmoreland
Dallas, Texas 75237/(214) 339-0753 • Fax (214) 339-1313

FORTRAN for the 80386

- Source Level Symbolic Debugging
- Uses All Available Memory
- Runs in the 32-bit Protected Mode
- Royalty Free License on Developed Programs
- DOS Support Library with Source code

Put the full power of the 80386 into your programs. Our SVS FORTRAN-386 compiler breaks DOS's 16-bit instruction and 640K memory limit. With SVS you can cut a typical program's run-time in half, while using up to 16 Megabytes of memory. SVS fully supports both the Intel 80287/80387 and the Weitek 1167 math co-processors. SVS FORTRAN-386 needs the Phar Lap-386 Linker.

Supporting Software Tools:

SSP(Scitech Scientific Package) with Source Code Included
Mathematical and Statistical Routines ~ Fast Fourier Transforms (FFT)
~Specialized Matrix-Inversion Routines ~ Integration Utilities ~ Polynomial Roots~Nonparametric Statistics

SPP(Scitech Plotting Package) with Source Code Included
Supports CGA, EGA, MCGA, VGA, Hercules and AT&T 6300 graphic displays. Plots can be created and displayed or saved in a disk file with provision for enlarging, reducing, translating and rotating the original plot.

MAT(Maintainability Analysis Tool)

MAT analyzes and diagnoses your FORTRAN programs, documents each module's interface, including all intercommunicating modules and generates cross-reference tables. MAT provides the information you need to make your programs more reliable and easier to maintain.

Prices:

SVS FORTRAN-386.....	\$695
SVS PASCAL-386.....	\$695
Phar Lap-386 ASM/LINK.....	\$495
Scitech Scientific Package.....	\$325
Scitech Plotting Package.....	\$325
Maintainability Analysis Tool.....	\$595

For more information call:

1-800-346-5159

In CA call (415) 960-5931

SAIC
Science Applications
International Corporation

5150 El Camino Real, Suite C-31
Los Altos, California 94022

An APT Example

Assume you are writing an essay on the economic causes of the American Civil War. APT helps you handle this by getting you to organize your thoughts into three segments: Ideas, Connectors, and Connections (see figure 1).

In the Ideas segment, you list the principal ideas of your paper, each followed by a semicolon. The compiler considers the words between semicolons as a token, a separate entity that represents each idea or connector. The same word can appear in different tokens, and one token can be a prefix of another. You can include additional thoughts and explanations between brackets, and the program will ignore these words.

The Connectors segment defines various words that will join two ideas. They are stored as separate tokens that may contain words from other tokens and other connectors as prefixes. In figure 1, for example, "helps" and "different from" are connectors. "Helps greatly" is also a perfectly acceptable connector. The compiler treats it differently than "helps." The parser's current design limits you from using the same word in both an idea and a connector. You should not find this situation too much trouble, though, because ideas will generally consist of nouns, and connectors will generally consist of verbs.

There are three different types of connectors. Ordinary ones (also called symmetric) place no restrictions on the order the two ideas will take in the outline, while left and right connectors force the compiler to develop either the left or the right side of the equation first.

In figure 1, the program defines the verb "helps" to be a left connector. When the compiler reaches the clause "automation helps northern factories," it places the left side of the equation, "automation," first in the outline. The link "helps" forces the topic of "automation" to be developed before "northern factories." If the connector is a right one, the right side comes first. "Requires" is a right connector, so in the phrase "plantation labor requires slavery," in the final outline, "slavery" will come first.

You specify whether a connector is left or right by placing a colon immediately after it and writing the word left or right in capital letters. Unspecified tokens are assumed to be symmetric. In figure 1, "or" is a symmetric token.

In the Connections segment, you draw together your ideas in pairs with connectors. Each of these new idea-connector-idea clauses forms a new idea, and you can link these clauses with nested parentheses in patterns such as "(idea-connector-idea) connector-idea." The first connector idea in parentheses now acts as a new idea. If you plan carefully, then when the ideas and connections are defined, the resultant clauses may come close to being grammatically correct. In figure 1, I defined "does not help" as a connector so it could join two ideas together in an English-like sentence.

The program takes a text file for input. You can create the file with any editor or word processor that stores the words in a simple text-file format with no control characters or escape sequences. You need to make the files look exactly like figure 1, using the words IDEAS, CONNECTORS, CONNECTIONS, LEFT, and RIGHT.

Semicolons must separate the different ideas, connectors, and phrases, but a period must come after the last item in each segment. The program asks for the names of the input and output files. The output file will contain all the error messages.

The compiler encourages free-form thinking by accepting Ideas, Connectors, or Connections segments in practically any order. It only requires that the ideas and connectors used in a clause be defined in a previous section. Two outlines can easily be combined by cutting and pasting complete segments from

continued

Concurrent DOS 386

Think small in a big way

When you think multiuser/multitasking, think Concurrent™ DOS 386, the big name in small systems from Digital Research®, architects of the first standard operating system for personal computers. Now, Concurrent DOS 386 allows multiple users to share peripherals, files and applications, using serial terminal workstations linked by RS-232 cables to the system. It's fast, reliable and economical.

The big news today is small systems

Concurrent DOS 386 meets the increasing demands placed on small systems by supporting multiple DOS programs on both the system console and attached terminals. You can run popular programs such as Lotus® 1-2-3®, dBase® III, WordPerfect® and many more, with full math coprocessor support. The system runs up to 255 tasks simultaneously, with full intertask communications and byte-level record, file and device locking.

For people who hate waiting in line

Concurrent DOS 386 brings you all the remarkable speed and power of the Intel® 80386 processor. A prioritized pre-emptive scheduler allows task execution

and intertask communication by several users at near full processor speed while letting some tasks "interrupt" others according to the needs of each user.

A small system with a big memory

Concurrent DOS 386 gives you access to four gigabytes of linear physical memory. Its powerful memory paging capability fully supports the Expanded Memory Specification with no additional hardware or software.

Menus at a touch

Now you can create and customize menus, while programmable function keys let you condense complex commands to a single keystroke. The file manager runs standard operating system functions, plus you have an on-line help facility, text editor and support for DOS-based device drivers.

Multiuser color graphics

Now with the introduction of the newest member of the Concurrent DOS family, Concurrent DOS 386/Multiuser Graphics Edition, your demands for high-resolution EGA bit-mapped graphics in the workstation environment can

be met. Take advantage of advanced technology allowing you to run popular DOS-based graphics programs on individual workstations as well as on the system console without sacrificing system performance. Ask us about this exciting new version of Concurrent DOS 386.

All you have to remember is Concurrent DOS 386

Concurrent DOS 386 from Digital Research is the name to remember when it comes to 386 technology. The power and versatility of Concurrent DOS 386 are giving a new meaning to the word multiuser.

**CALL DIGITAL RESEARCH AT
1-800-443-4200 AND ASK FOR OUR
CONCURRENT DOS PROGRAMMER
INFORMATION KIT.**

CONCURRENT DOS 386: SHARING THE SYSTEM AFFORDABLY

Digital Research and the Digital Research logo are registered trademarks, and Concurrent is a trademark of Digital Research Inc. Other product names are registered trademarks or trademarks of their respective owners. Specifications are subject to change without notice. Copyright © 1988, Digital Research Inc. All rights reserved.

 **DIGITAL RESEARCH®**

Describe: slavery
Describe: plantation labor
Show how: plantation labor requires slavery
Describe: southern farming
Show how: southern farming requires plantation labor
Describe: northern farming
Show how: farming differences = northern farming different from southern farming
Describe: economic differences
Show how: farming differences lead to economic differences
Describe: automation
Show how: automation does not help plantation labor
Describe: northern factories
Show how: automation helps northern factories
Describe: tariff
Show how: tariff helps northern factories
Show how: automation helps northern farming
Show how: farming differences and economic differences
Describe: Civil War
Show how: (farming differences and economic differences) leads to Civil War

Figure 2: The outline produced by APT from the text in figure 1.

IDEAS

Definition of right triangle; [a triangle with one right angle.]
 Pythagorean theorem; [a squared plus b squared equals c squared.]
 Definition of sine; [sine is the ratio between the opposite side and the hypotenuse]
 Definition of cosine; [cosine is the ratio between the adjacent side and the hypotenuse]
 Transcendental identity. [sine(x) squared + cosine(x) squared = 1]

CONNECTORS

and;
 implies:LEFT.

CONNECTIONS

Definition of right triangle implies Pythagorean theorem;
 (Pythagorean theorem and (definition of sine and definition of cosine)) implies transcendental identity.

Figure 3: You can use APT for outlining material that needs to be precisely organized, such as mathematical proofs. The outline shown here is a proof of a trigonometric identity.

one into another. You just need to make sure all the necessary ideas and connectors are carried along into the new outline.

How the Outliner Organizes

When the APT compiler finishes reading the tokens, it tries to create an outline using the basic ideas and the connections that must be made between them. It starts by selecting one of the clauses in the Connections segment and stepping through the ideas in it one by one. The ideas that should be joined together are placed one after the other. Then the connection between two ideas is inserted into the outline immediately after the ideas are defined.

Figure 2 shows the results of running the outline in figure 1 through APT. When the compiler develops the clause "plantation labor requires slavery," it asks you to describe first slavery, then plantation labor. Right after these two ideas are introduced, it asks you to show how they are connected—that is, how plantation labor requires slavery. The words "describe" and "show how" are two stock phrases the compiler uses when it creates the final outline.

The outliner takes the list of ideas and organizes them. Initially, it chooses the clause that holds the first idea on the Idea list and develops those thoughts. Then it chooses the next clause containing the idea that is closest to the beginning of the Idea list. APT continues with this pattern until all the clauses are processed. It breaks any tie by choosing the clause that occurs first in the Connections section. Thus, "slavery" winds up first in the outline because you placed it first in your list of ideas.

After the system is finished with the first clause, it moves on and processes clause after clause until the program is done. If an idea appears in several clauses, the outliner will ask you to describe it only once. After that, the outliner will assume the concept is familiar. When you run your first input through the outliner, you should get the results shown in figure 2.

As the program organizes the ideas within each clause, it checks for left and right connectors and starts with the ideas on the appropriate side of the connector first. When it comes to ideas joined by symmetric connectors, it places the ideas in the outline in the same order as they are defined in the Ideas segment. This rule gives you some control over the final order of the outline, but the program will resort to the rule only after it finishes placing all ideas close to the other ideas with which they are being connected.

The next version will include an option that prevents the outliner from even considering using the topic on the right side of the left connector before the left side is used, and vice versa. In this case, there would be a dependency relationship between the clauses. The program would not develop a clause until all the other clauses it depends on are developed. Such a feature would be useful in situations requiring rigorous logical development, such as mathematical proofs. Figure 3 is a good example.

In figure 3, "implies" forces the left side, the necessary condition, to be developed before the right side. No matter how you rearrange the ideas, the compiler ensures that the left side of each connector "implies" comes before the right. It also places the first clause, "definition of right triangle implies Pythagorean theorem," before the second clause that uses "Pythagorean theorem" as a necessary condition on the left side of "implies." It wouldn't make sense to consider the second clause before the first clause is proven.

You can also break up the outline into a sequence of short Ideas, Connectors, and Connections segments so the definition of an idea is close to its use in a connection. This allows you to break the outline into more manageable segments—a process

continued

Make your programs millions of times smarter

More and more, programmers and workstation builders are using DESQview 2.0 as a development tool. The reason is simple. They can create powerful, multitasking solutions today for the millions of DOS PCs in use today. Solutions comparable to those promised for tomorrow by OS/2.

The API Advantage

Programmers who take advantage of DESQview's API (Application Program Interface) get access to the powerful capabilities built into DESQview—multitasking, windowing, intertask communications, mailboxes, shared programs, memory management, mousing, data transfer, menu-building and context sensitive help.

Bells and Whistles

A program taking advantage of the DESQview 2.0 API can spawn subtasks for performing background operations or run processes for loading and running other programs concurrently. It can schedule processing after an interval or at a certain time. It can use DESQview's intertask communications to rapidly exchange data between programs, share common code and data; or interrupt at critical events. It can use DESQview's menuing and mousing capabilities to create menus. And there's lots more it can do.

Some of the applications under development right now using DESQview 2.0 API Tools: CAD, medical systems, insurance, 3270 mainframe communications, network management, real estate, typesetting, point of sale, education, commodity trading, stock trading and online voting.

80386 Power

80386 programmers can take advantage of the 80386's protected mode for large programs, yet run on DOS and multitask in DESQview—side by side with other 80386 and DOS programs. The breakthroughs that make this possible: DOS Extenders from PharLap Software and AI Architects and DESQview support of these DOS extenders.

DESQview Developer Support

So if you are a developer, looking to create programs with mainframe capabilities, but wanting to sell into the existing base of millions of DOS PCs, we can be very helpful. We offer DESQview API Tools for assembler or C programmers: a debugger, a Reference Manual. And lots more tools on the way.

Plus, we offer DESQview API Developers Conferences. Come learn about the DESQview 2.0 API and 80386 DOS Extenders. Meet 80386 experts as well as those smart people who are creating DESQview 2.0 API workstation solutions.

For more information call or write us.

Bringing New Power to DOS. DESQview 2.0 API Toolkit.

The logo for Quarterdeck, featuring the word "Quarterdeck" in a bold, red, sans-serif font. To the left of the text is a stylized graphic consisting of several parallel diagonal lines of varying lengths, creating a sense of motion or a deck.

Quarterdeck Office Systems, 150 Pico Blvd., Santa Monica, CA 90405
(213) 392 9851

IDEAS

Marie;
Jean-Phillipe;
François.

CONNECTORS

loves;
is married to;
doesn't know that.

CONNECTIONS

Marie loves François;
Marie is married to Jean-Phillipe;
Jean-Phillipe doesn't know that (Marie loves François);
François doesn't know that (Marie is married to Jean-Phillipe).

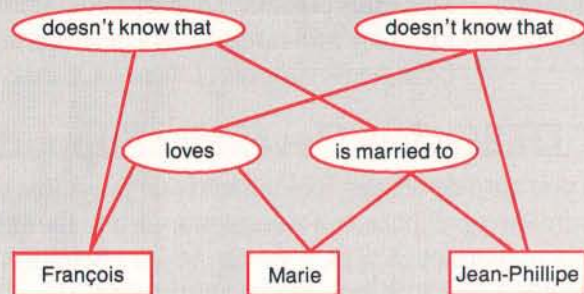

Figure 4: The outline generator performs its work by representing the ideas in each clause as nodes. As more and more links are created, a directed acyclic graph, such as this one outlining a movie plot, is constructed. Each connection is added to the graph by creating a new node with pointers to the two nodes it connects.

Describe: Marie

Describe: Jean-Phillipe

Show how: Marie is married to Jean-Phillipe

Describe: François

Show how: François doesn't know that (Marie is married to Jean-Phillipe)

Figure 5: The outline produced from the acyclic graph in figure 4. The program produces this outline by searching downward from the root (the highest node in each clause). When it locates two ideas, it walks back up the structure, joining them, and continues making all the connections until it reaches the root again.

roughly equivalent to defining a subroutine, but it does not include any notion of global and local ideas. Everything is global.

APT's Algorithm

The outline generator performs its work by creating a structure called an acyclic graph. A different node represents each idea. The program adds each connection by generating a new node with pointers to the two nodes it connects, as shown in figure 4. This new node is said to be "higher" than the two nodes it joins. The highest node is the last one entered in the graph for each clause. The connections are shown as two lines from the connector pointing downward to the ideas that are joined.

The program easily produces an outline from this structure. The highest node in each clause is known as the root. The program develops clauses by searching downward from the root. The idea nodes in each clause are at the foundation level. Every connector made is higher. When the program finds two ideas, it moves back up, joining them, and continues to make all the connections until it reaches the root again, as shown in figure 5. At each node, the program checks to see if the node is a left or right connector. If it is either, the outliner chooses the appropriate branch to be examined before the other. Otherwise, it picks the branch—either the left or the right—that leads to the first idea on the list. If it finds a node that another clause has used before, it stops here and moves back up the tree.

The outliner chooses between clauses by examining the positions of the idea nodes in the Ideas list. It picks the clause that includes the earliest idea defined in the APT program. This feature gives you some control over the order in which your ideas appear. If you want to rearrange your paper and move "farming differences," for example, so that this subject appears earlier in your material, you can move this idea to the top of the Ideas segment, and the outliner will do its best to accommodate the change.

The parser builds the tree with the help of symbol tables. In APT's present design, each word is a separate entity that is stored in a symbol table. Each token is saved as a list of words in its own table. As it constructs the directed acyclic graph, the program maintains a list of idea-connector-idea triplets already entered in the graph and checks to see if the particular phrase being processed is already there. If so, the program uses the existing location in the graph; if not, it constructs a new one.

Ordinarily, ideas end up as nodes at the bottom of the graph, but this doesn't have to be so. An equal sign can attach the idea to a node much higher in the graph.

For example, in figure 6, the equal sign connects the phrase "Joyce's Oeuvre" with the small tree representing three of his major books. Now these books can be referred to by the token Joyce's Oeuvre, and the token will represent the three. The system asks you to introduce the three books only once, when it first comes to Joyce's Oeuvre in a branch. From then on, it refers to the books as Joyce's Oeuvre.

You can use APT for many applications that require planning. Construction projects, for example, have phases that depend on one another, such as "the first floor requires a foundation before it can be built." You can easily convert these scenarios for APT's use by listing every step as an idea and connecting them with left or right connectors such as "must precede" or "requires." APT will try to arrange it so that connected stages of the project appear near each other in the outline.

Strengths and Weaknesses

At this point, it might appear as if this tool is only useful for disciples of Bertrand Russell and others who think that all

continued

Get your work done before 1991?

The future of personal computing is clear. More powerful PCs. Easier to use PCs. With graphics and character-based programs working side by side. Talking to each other. Multitasking. Windowing. Menuing. Mousing. Getting your work done easier and faster.

Have it all now.

DESQview™ is the operating environment that gives DOS the capabilities of OS/2™. And it lets you, with your trusty 8088, 8086, 80286, or 80386 PC, leap to the productivity of the next generation. For not much money. And without throwing out your favorite software.

Add DESQview to your PC and it quickly finds your programs and lists them on menus. So you can just point to the program, using keyboard or mouse, to start it up. DESQview knows where that program lives. And what command loads it.

For those who have trouble remembering DOS commands, it adds menus to DOS. It even lets you sort your files and mark specific files to be copied, backed-up, or deleted—all without having to leave the program you're in.

Best of all, DESQview accomplishes all this with a substantial speed advantage over any alternative environment.

Multitask beyond 640K.

When you want to use several programs

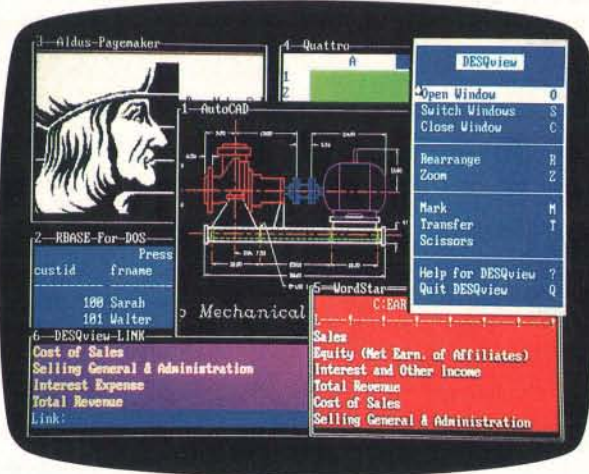

For programmers, DESQview's API, with its strengths in inter-task communications and multitasking, brings a quick and easy way to adapt to the future. With the API's mailboxes and shared programs, programmers are able to design programs running on DOS with capabilities like those of OS/2.

together, you don't have to leave your current program. Just open the next program. View your programs in windows or full screen. Open more programs than you have memory for. And multitask them. In 640K. Or if you own a special EMS 4.0 or EEMS memory board, or a 386 PC, DESQview lets you break

through the DOS 640K barrier for multitasking. You can start 1-2-3 calculating and tell Paradox to print mailing labels while you're writing a report in Word Perfect, or laying out a newsletter in Ventura Publisher, or designing a building in AutoCAD.

DESQview even lets you transfer text, numbers, and fields of information between programs.

Fulfill the 386 promise.

For 80836 PC users, DESQview becomes a 386 control program when used in conjunction with Quarterdeck's Expanded Memory Manager (QEMM)-386—giving faster multitasking as well as virtual windowing support.

And when you use DESQview on an IBM PS/2™ Model 50 or 60 with QEMM-50/60 and the IBM Memory Expansion Option, DESQview gives you multitasking beyond 640K.

Experts are voting for DESQview. And over a million users, too.

If all of this sounds like promises you've been hearing for future systems, then you can understand why over a million users have chosen DESQview. And why PC



Magazine gave DESQview its Editor's Choice Award for "The Best Alternative to OS/2," why readers of InfoWorld twice voted DESQview "Product of the Year" why, by popular vote at Comdex

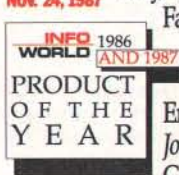

Fall for the last two years in a row, DESQview was selected as "Best PC Environment" in PC Tech Journal's Systems Builder Contest.

DESQview lets you have it all now.

DESQVIEW SYSTEM REQUIREMENTS:

IBM Personal Computer and 100% compatibles (with 8086, 8088, 80286, or 80386 processors) with monochrome or color display; IBM Personal System/2* Memory: 640K recommended; for DESQview itself 0-145K* Expanded Memory (Optional): expanded memory boards compatible with the Intel AboveBoard; enhanced expanded memory boards compatible with the AST RAMpage; EMS 4.0 expanded memory boards* Disk: two diskette drives or one diskette drive and a hard disk* Graphics Card (Optional): Hercules, IBM Color/ Graphics (CGA), IBM Enhanced Graphics (EGA), IBM Personal System/2 Advanced Graphics (VGA)* Mouse (Optional): Mouse Systems, Microsoft and compatibles* Modem for Auto-Dialer (Optional): Hayes or compatible* Operating System: PC-DOS 2.0-3.3; MS-DOS 2.0-3.2* Software: Most PC-DOS and MS-DOS application programs; programs specific to Microsoft Windows 1.03-2.03, GEM 1.1-3.0, IBM TopView 1.1* Media: DESQview 2.0 is available on either 5-1/4" or 3-1/2" floppy diskette.

YES!
I need increased productivity now!

Qty	Product	Format	Price Each	Totals
	DESQview 2.0	<input type="checkbox"/> 5-1/4 <input type="checkbox"/> 3-1/2	\$129.95	
	QEMM-386	<input type="checkbox"/> 5-1/4 <input type="checkbox"/> 3-1/2	\$59.95	
	QEMM-50/60	<input type="checkbox"/> 5-1/4 <input type="checkbox"/> 3-1/2	\$59.95	
Shipping & Handling \$5 in USA/ \$10 outside USA				
Calif Residents add 6.5%				
Grand Total				

Name _____
 Address _____
 City _____ State _____ Zip _____
 Payment Method Visa MasterCard Expiration ____/____
 Account # _____

Quarterdeck

150 Pico Boulevard, Santa Monica, CA 90405
(213) 392-9851

Want to save Time, Money,
& Headaches?

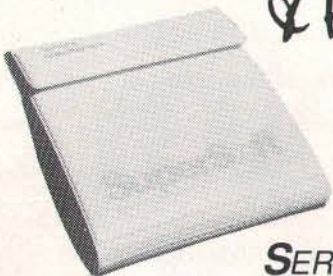

GET SUPERSOFT'S
SERVICE DIAGNOSTICS

All the software, alignment diskettes, parallel/serial wrap-around plugs, ROM POSTs and extensive, professional documentation to provide the most comprehensive testing available for IBM PCs, XTs, ATs and *all compatibles* under DOS or Stand Alone. No other diagnostics offers such in-depth testing on as many different types of equipment by isolating problems to the board and chip level.

NEW: SuperSoft's ROM POST performs the most advanced **Power-on-Self-Test** available for system boards that are compatible with the IBM ROM BIOS. It works even in circumstances when the Service Diagnostics diskette cannot be loaded.

NEW: 386 diagnostics for hybrids and PS/2s!

For over nine years, major manufacturers have been relying on SuperSoft's diagnostics software to help them and their customers repair microcomputers. End users have been relying on SuperSoft's Diagnostics II for the most thorough hardware error isolation available. Now versions of Service Diagnostics are available to save everyone (including every serious repair technician) time, money, and headaches in fixing their computers, even non-IBM equipment.

All CPUs & Numeric Co-processors	All Color Graphics & Monochrome Monitors
System Expansion & Extended Memory	Parallel & Serial Ports
Floppy, Fixed & Non-standard Disk Drives	Mono, CGA, Hercules & EGA Adapters
Standard & Non-standard Printers	All Keyboards & the 8042 Controller
System Board: DMA, Timers, Interrupt, Real-time Clock & CMOS config. RAM	

Join the ranks of XEROX, NCR, CDC, SONY, PRIME, ... who have bundled SuperSoft's diagnostics with their microcomputers at no risk because of our 30 day money back guarantee.

Service Diagnostics for PC, PC/XT, and compatibles only\$169
Alignment Diskette for PC, PC/XT and compatibles (48 tpi drives)\$ 50
Wrap-around Plug for PC, PC/XT and compatibles (parallel and serial)	..\$ 30
Service Diagnostics for AT and compatibles only\$169
Alignment Diskette for AT and compatibles (96 tpi drives)\$ 50
Wrap-around Plug for AT (serial)\$ 15
ROM POST for PC, PC/XT and compatibles only\$245
ROM POST for AT and compatibles only\$245
Service Diagnostics: The KIT (includes all of the above—save \$502)\$495
Service Diagnostics for 386 or V2, V30, or Harris, etc. (please specify)\$195
Diagnostics II is the solution to the service problems of users of all CP/M-80, CP/M-86 and MS-DOS computers\$125
ROM POST for PS/2 and compatibles only\$245
Alignment Diskette for PS/2 and compatibles (3.5 inch)\$ 50

To order, call 800-678-3600 or 408-745-0234
FAX 408-745-0231, or write SuperSoft.

your microcomputer repair solution

SuperSoft

FIRST IN SOFTWARE TECHNOLOGY P.O. Box 611328, San Jose, CA 95161-1328 (408) 745-0234 Telex 270365

SUPERSOFT is a registered trademark of SuperSoft, Inc.; CDC of Control Data Corp.; IBM PC, AT & XT of International Business Machines Corp.; MS-DOS of MicroSoft Corp.; NEC of NEC Information Systems, Inc.; PRIME of PRIME INC.; Sony of Sony Corp.

IDEAS

The Dubliners;
Ulysses;
Finnegan's Wake;
Joyce's Oeuvre;
The city of Dublin;
A literary version of Dublin.

CONNECTORS

rises from;
centers around;
and.

CONNECTIONS

Joyce's Oeuvre = The Dubliners and Ulysses and
Finnegan's Wake;
Joyce's Oeuvre centers around the city of Dublin;
A literary version of Dublin rises from Joyce's Oeuvre.

Figure 6: With APT, you can group parts of the outline together using an equal sign. In this example, the equal sign connects three of Joyce's major books so they can therefore be referred to by the token "Joyce's Oeuvre."

knowledge can be atomized and neatly connected. This is not necessarily the case. Inside the system, each connector is represented as a pointer in a graph; but outside, the connector is just a word. The connection can be as strong as the word "implies" or as ephemeral as the nebulous phrase "might have something to do with." The nature of the link depends entirely on your choice of words.

This is one of the strengths of the APT system. It lets you be as colloquial or as proper as you wish. Your ideas might be sketchy slang or well-thought-out parts of a sentence. But, in the end, the system will do the work and arrange everything as best as it can. It lets you concentrate on making lists of ideas and thinking through the best way to join the ideas before you begin to write.

You might find learning to link your ideas difficult. But many people who've used the system say that before they learned it, their outlines were merely lists of ideas without firm connections between them. They would link the topics as they wrote and often make substantial revisions to the outline. The APT system helps you organize your material earlier, when you can more easily experiment and change things.

Many people, especially nontechnical writers, may balk at using such a logical way of planning and outlining. They may say, "Good writing isn't mathematics." True, some literature may be free-flowing and not strictly structured, but most writing must have a logical structure so it can be understood.

APT forces you to think through the details of your writing project. But because the machine does the organizing, the program frees you from worrying about the overall structure. With luck, you will discover that joining ideas is a more natural way to construct an outline. Once that is done, all you have to do is the writing. ■

Editor's note: *The source code for APT is available in a variety of formats. See page 3 for details. The code was written with Lightspeed Pascal; however, minimal changes should allow it to work with other versions of Pascal.*

Peter Wayner is reading toward a Ph.D. in computer science at Cornell University. He can be reached on BIX c/o "editors."

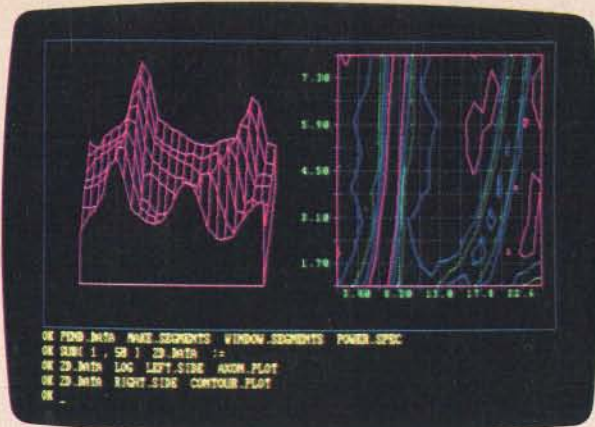

Single commands like CONTOUR.PLOT instantly generate presentation-quality graphics.

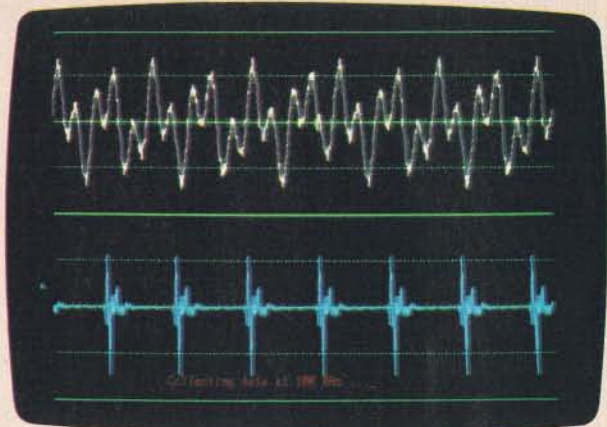

With proper hardware, ASYST acquires data at rates of up to 250KHz.



It takes just one command and 47 milliseconds to calculate the inverse of a general 9 x 9 matrix.

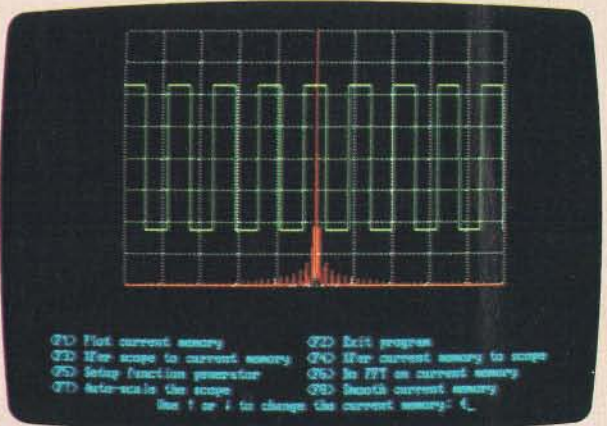

Join the thousands of users who get significantly faster solutions with ASYST.*

Screen Tests.

Go ahead.
Try this with any other single PC software package.

Sure, you could create these screens by using several scientific software packages. (Of course, you'd have to learn several different systems and convert your data files a few times.) But we did it all with just one, integrated, scientific software tool. A tool that can handle all your needs—data acquisition, analysis, and graphics—ASYST.

ASYST gives you full control of your data. Within one, unique, interactive programming environment you have access to high-level commands that allow you to perform functions like instrument interfacing and control, FFTs, smoothing, integration, differentiation, curve fitting, statistics, and matrix and polynomial operations.

But even though the ASYST function set is extensive, you're not tied to it. You can expand and customize the functionality of ASYST by tailoring its capabilities to your needs. And you'll find, as thousands of satisfied users have, that you don't have to be a professional programmer to use it.

And just in case you need it, you'll appreciate our 60 days of free technical support. Ongoing support is available.

Test ASYST on your own screen with our 30-day no-risk offer. Call 1-800-348-0033.

A complete system:

- Data analysis and statistics
- Acquisition (A/D, D/A, and Digital I/O)
- Instrument interfacing and control (IEEE-488/GPIB and RS-232)
- High-performance graphics

System Developers: Ask about the ASYST run-time and User site licenses.

*1024 point complex FFT calculated in 422 milliseconds. All benchmarks based on a 20MHz 386 computer with 857 coprocessor.

Circle 34 on Reader Service Card

ASYST
SOFTWARE TECHNOLOGIES, INC.

100 Corporate Woods, Rochester, NY 14623
1-800-348-0033 or 716-272-0070

ASYST is a trademark of Asyst Software Technologies, Inc.
©1988 Asyst Software Technologies, Inc.

NOVEMBER 1988 • BYTE • 185

The Hot Performers.

“Solid performance and low price make this system an excellent value.”
—InfoWorld

ME 386-20
Tower

ME 386-18

ME 386-20

20 MHz 80386-20 processor Microsoft OS/2 and DOS compatible 1 MB 32-bit RAM running at “0” wait state (upgradable to 8 MB) Socket for 80387/80287 math co-processor High performance NCL floppy/hard disk controller 1.2 MB floppy disk drive CMOS clock/calendar with battery back-up Enhanced keyboard

\$2350

Upright Case
Add \$300



ME 386-18

18 MHz 80386 processor Microsoft OS/2 and DOS compatible 512K 32-bit memory on board Two 32-bit expansion slots Socket for 80387 math co-processor High-performance NCL floppy/hard disk controller 1.2 MB floppy disk drive CMOS clock/calendar Enhanced AT keyboard

\$1799

★ SPECIAL ★

ME V20 64K (upgradable to 640K) 360K floppy disk drive Monochrome graphics card Monochrome monitor Keyboard Complete system...\$499.00

HOT PORTABLES

ME Roadrunner

12 MHz 80286 processor Socket for 80287 math co-processor 640K memory (1 MB option) New Super-Twist LCD with Backlit and Reverse; 640 x 200 dots (640 x 400 option); 80 char. x 25 lines Monochrome/Color graphics card for external monitor 6 expansion slots Floppy/hard disk controller Serial/parallel/clock-calendar 1.2 MB floppy disk drive 20 MB hard disk (30, 40, or 60 MB optional) 12-function AT style keyboard 110/220V auto-switchable 20 pounds

\$1799

Roadrunner Plus (386)

Intel 80387 processor 6/16 MHz clock speed 1 MB of memory Socket for math co-processor Floppy/hard disk controller 1.2 MB high capacity floppy disk drive 42 MB fast access hard disk (60 MB optional) Serial/parallel ports Color/mono display card for external monitor New Super-Twist LCD with Backlit and Reverse; 640 x 400 dots; 80 characters x 25 lines 6 expansion slots 12-function keyboard 110/220V auto-switchable 20 pounds

\$3399

ME 286-12

8/12 MHz 80286 processor 512K memory (upgradable to 1 MB on board) “0” wait state option (s.i. 15.3) Microsoft OS/2 and DOS compatible 8 I/O expansion slots High-performance NCL floppy/hard disk controller 1.2 MB floppy disk drive CMOS clock/calendar Enhanced keyboard

\$899

The Network Solution

ELS Network for two-to-four users. Increase your company's productivity without making a big increase in expenditures. Complete software... **\$499**

Call for all Novell Products

Prices and availability subject to change without notice.



CALL TOLL-FREE

(800) MICRO-21
in Calif. (714) 662-1973

ME MICRO EXPRESS

2114 South Grand Avenue
Santa Ana, California 92705
Fax: (714) 662-1258 - Telex: 910 240 3029

Come See Us At COMDEX Booth #C607

PARALLELIZING PROLOG

Three approaches to running Prolog programs on multiprocessor machines

Dick Pountain

Once found only in academic environments, Prolog has graduated to the real world and is now available for just about every computer made. Applications developers are finding that Prolog's symbol-manipulation and built-in pattern-matching abilities make it particularly suited for programming expert systems, database query systems, and natural-language processing systems.

Such applications typically involve searching very large databases and need very fast computers to achieve adequate performance. They are therefore natural candidates for being sped up by parallel processing. Almost from its inception, Prolog researchers have wanted to implement the language on multiple CPUs so that the sequence of pattern matches that are involved in solving a Prolog goal would all be evaluated at the same time. Efficiency is not the sole rationale for this desire for parallelism; the philosophy of pure logic programming itself indicates that the order of evaluation of a program should not matter. What better way to escape from this order than by doing everything at the same time?

At a superficial glance, Prolog appears to be well suited to parallel evaluation. Prolog programs are descriptions of the problem rather than prescriptions for how to solve

it. There is nothing in the text of a Prolog program that explicitly states in what order its parts should be evaluated.

However, all is not so simple as it seems. Prolog has to run on real-life computers and is only an approximation to the timeless, purely logical style of programming. Prolog programs use variables to hold values and so have an execution history, however fleeting. Although many features of Prolog make it more suitable for parallel execution than conventional languages, running tasks in parallel requires mechanisms for communication and synchronization between processes—mechanisms that

are not present in current dialects of Prolog.

Research on parallel-logic programming languages is being pursued at a number of centers in the U.S., U.K., West Germany, Hungary, Portugal, and Australia, not forgetting, of course, the Japanese Fifth Generation Project, an important component of which is a parallel Prolog system. Recently, some implementations of parallel Prolog or Prolog-like languages have begun to filter out into the light of day, and at the 1988 CEBIT Electronics Fair in Hannover, West Germany, I encountered no less than three of them, each using different strategies.

CS-Prolog was developed by Ivan Futo and Janos Szeredi at the Computer Research Institute in Budapest, Hun-

continued



gary; Parsytec Prolog is from the German firm Parsytec; and the most radical solution to parallelizing Prolog, PARLOG, is a new language developed at Imperial College, London, by Keith Clark and Steven Gregory. (If you are not familiar with the structure of Prolog programs, the text box "Prolog Basics: Unification and Backtracking" on page 390 will set the stage for discussing parallelism in Prolog.)

The Old Order

Sequential Prolog uses a strategy called *depth-first, left-to-right* search, so that execution proceeds by first trying the clauses for a relation in sequence (down the page in the source code) and then, when a match is found, by trying the subgoals of the clause's body from left to right in sequence (across the page). People often prefer to talk about the OR and AND dimensions because the clauses of a Prolog program are connected by an implied logical OR, and the subgoals of a clause body by an implied AND (some dialects allow you to write this AND explicitly in place of commas).

The distinction between these two dimensions is important, as each requires different trade-offs to parallelize them, and it is possible to parallelize one dimension while leaving the other strictly sequential. In an OR-parallel Prolog, you would match a goal against all the clause heads simultaneously; the problem then amounts to choosing which one to evaluate, supposing more than one of them unifies. In an AND-parallel Prolog, you would test the clause heads in sequence as usual, but once one was unified, all the subgoals in its body would be evaluated simultaneously. The problem here is that since these subgoals may share variables, who gets to bind the variable? This is just the classic problem of communication and synchronization faced by all concurrent programmers. In both cases, the question of what happens to backtracking becomes a crucial matter. Let's now look at three different sets of solutions to these problems.

CS-Prolog

Communicating Sequential Prolog (CS-Prolog) works by adding the notion of time to Prolog, allowing you to suspend the execution of goals until certain conditions are met. CS-Prolog embodies a kind of AND parallelism, in the sense that subgoals can be concurrently processed by sending messages to activate other processes. This communication must be explicitly controlled by the programmer.

CS-Prolog runs on either a single-processor or multiprocessor implementation. In a single-processor system, CS-Prolog employs no actual or simulated parallelism, since there is never more than one process active at a time. However, CS-Prolog is currently being implemented on a network of INMOS transputers, and, in such an environment, each process is executed on a separate processor.

CS-Prolog adds a number of built-in predicates, the most important of which are `new()`, `send()`, `wait_for()`, and `hold()`. The predicate `new()` creates processes dynamically during a program run (a process is a Prolog goal that has its start time and end time specified but is otherwise evaluated just like an ordinary goal). The full syntax for a process creation is

```
new(Goal, Processname, Start, End).
```

The function `send(M, Processlist)` sends a message `M` to all the processes named in `Processlist`, and `wait_for(R)` suspends a process until it receives a message that will unify with `R`. A message can be any Prolog term. The function `hold(T)` suspends a process for a specified length of time `T`, while sus-

`pend(P)` suspends a process unconditionally so it can only be reactivated with `activate_suspended(P)`.

There now arises the problem of how to cope with backtracking in such a distributed system. CS-Prolog distinguishes two kinds of backtracking: local and global.

In local backtracking, a process does not pass a communication point, that is, a point at which the process sent or received a message; local backtracking is always permitted and does not affect any other processes.

In global backtracking, a process passes one or more communication points and thereby directly affects the execution of other processes. Whenever the backtrack reaches a point where the process had sent messages using `send()`, then *anti-messages* are sent to those same processes, causing them to backtrack as well. The backtracking of the original process continues. On the other hand, when backtracking arrives at a point where the process has received messages via a `wait_for()`, and if there are any matching messages still waiting to be processed, the first one is selected and execution proceeds forward again. If no messages are waiting, the process remains suspended.

It's possible for a deadlock to occur during global backtracking if all processes are suspended and there are no messages in transit. In this case, a global monitor process running on one of the transputers or on a host computer has to recognize the situation and intervene to break the deadlock; it does this by choosing one process and forcing it to backtrack further and repeating this treatment until some process arrives at a `send()`, which reactivates other processes.

Programming in CS-Prolog is in many ways reminiscent of concurrent procedural languages like Ada, Occam, or Modula-2. Brainware, a German software firm, is working on an MS-DOS version of CS-Prolog that will run on PC multitransputer boards.

Parsytec Prolog

Parsytec Prolog is a fully compiled Prolog that uses a form of restricted AND parallelism where the programmer explicitly labels the subgoals that are to be evaluated in parallel. Parsytec designed this Prolog to run on its transputer-based Megaframe parallel-processing computer, which allows the company to create a high-performance application environment for industrial and laboratory control. You can also run Parsytec Prolog sequentially.

The Parsytec compiler actually maps parallel calls onto a tree of processors, so that the first subgoal runs on the root processor, the second subgoal on the first child processor, and so on. At present, you must configure the physical tree by hand using fixed links before program loading. (A new version is in development that uses INMOS's digital switch chip to configure the tree electronically at run time.) You can use the predicate `par()` to determine the number of available processors and the dummy subgoal `idle()` for setting up time delays to make sure a real subgoal gets executed on a particular processor.

A parallel call in Parsytec Prolog looks like this:

```
goal(A,B) :- ( test subgoal_1(A) & subgoal_2(B) ).
```

The extensions to Prolog syntax are the `&` symbol, which replaces the comma to separate the subgoals of a parallel call, and the `|` symbol, called *guard*, which separates `test` from the body of the clause. If the condition `test` is true, then the two subgoals in the call body are evaluated in parallel; if false, the evaluation of the subgoals proceeds in a normal sequential

continued

Introducing...

MIRROR III

Full Spectrum Data Communications

From the occasional user to the experienced professional, today's PC communications software needs to cover the full spectrum.

Pre-programmed access to most popular dial-up information services • "Learn" mode to create your own log-on sequences • Dialing Directory • Installation and System Diagnostics • Comprehensive "HELP" system • 100% Crosstalk® XVI compatibility.

Background mode: Start a file transfer and switch to running another program while MIRROR III handles the transfer behind the scene.

Ultra High-Speed modem support (19,200 bps), or direct connect (up to 115,200 bps).

Host system connectivity with terminal emulations including: DEC VT 100/220 series, IBM 3101 (with block mode), Televideo 925 and Wyse-50.

File transfer protocols: XMODEM, YMODEM, KERMIT, Crosstalk, Hayes, CompuServe-B and ACT CommPressor™ (the latest in data compression).

PRISM: Introducing the most powerful data communications programming language. PRISM provides: Form/Menu generation; real, integer, string, and array variables; File I/O and the ability to integrate MIRROR III with foreground applications. A script file protection/compression utility is also provided.

Put the power of "Full Spectrum Data Communications" to work for you.
Order MIRROR III Today!

To order, Call: 1-800-634-8670
60-Day Money-back Guarantee

\$99.95

SOFTKLONE™

VISA/MasterCard/COD. \$5.00 for Shipping and Handling (\$8.00 for COD orders).
Florida residents add 6% sales tax.

MIRROR III is for use on IBM and 100% compatibles (including the IBM PS/2) running MS-DOS 2.0 or higher.

Crosstalk is a registered trademark of DCA, Inc./CommPressor™ is a trademark of ACT, Inc.

DISTRIBUTING CORP.
327 Office Plaza Drive
Tallahassee, Florida 32301
Telephone: (904) 878-8564
Telex: 6714280 KLON

Prolog Basics: Unification and Backtracking

Before understanding the three techniques for parallelizing Prolog, you need to understand the evaluation of a typical Prolog program. Using the Edinburgh syntax, you could define the Prolog relation `grandfather` as follows:

```
grandfather(X,G) :-
    father(P,G), mother(X,P).
grandfather(X,G) :-
    father(P,G), father(X,P).
```

What this says is that G is the grandfather of X if he is the father of X's mother or the father of X's father. The two lines beginning with `grandfather` are called *clauses*. The term `grandfather(X,G)` is the *head* of each clause, and the terms following the `:-` symbol make up the *body* of the clause. X, G, and P are variables. You can use this relation in conjunction with a database of facts about people's parents, such as

```
father(bill,tom).
father(tom,paul).
father(susan,tom).
father(sally,paul).
mother(bill,mary).
```

Then you could evaluate queries, or *goals*, like asking if Paul is Susan's grandfather:

```
? grandfather(susan,paul).
```

to which Prolog will reply yes. Alternately,

you can try to find all grandchildren of Paul.

```
? grandfather(Z, paul).
```

to which Prolog replies

```
Z = bill;
Z = susan;
no
```

When trying to solve such goals, Prolog attempts to *unify* the goal with the heads of all the clauses for the relation in question. Unification, which is the very heart of Prolog, is a mathematical technique that attempts to make two expressions identical by choosing suitable values for the variables they contain. When evaluating `grandfather(susan, paul)`, the Prolog interpreter tries to unify this expression with the first clause head and succeeds by making X = susan and G = paul (this process is called *binding* the variables). When a goal unifies with the head of a clause, Prolog then goes on to evaluate the body of that clause, taking each term in turn from left to right, but replacing any variables that have already been bound by their new values. These terms are called *subgoals* and are evaluated just like the original goal, by trying to unify them with the clause heads for their own relations. In the example, Prolog first tries `father(P, paul)`, which unifies with the second clause for `father` by making P = tom; then `mother(X,P)` is

evaluated and fails because Tom is not Susan's mother.

Although having failed to establish the truth of the clause body, Prolog does not give up. Instead it backtracks by undoing the binding of P in `father(P, paul)` and trying the next possibility, in this case P = sally, from the fourth clause. Sally is not Susan's mother, either, so the mother subgoal still fails, and there are no more possibilities for P. Prolog still perseveres by backtracking all the way; it undoes the bindings for X and G and tries the second clause for `grandfather`. This again unifies with X = susan, G = paul, and now the body of the clause succeeds with P = tom. This ability to backtrack lets Prolog find all the solutions to a query, as you will see if you trace the execution of `grandfather(Z,paul)` by hand.

In principle, the order of the clauses does not matter. You could shuffle the order of the `grandfather` or `father` clauses, and the goals would still succeed because of backtracking. However, backtracking takes time, and the order of the clauses *will* affect the speed of the program. If speed were the only consideration, you could eliminate the need for backtracking by trying all the possibilities at the same time, that is, in parallel, and dramatically increase performance. Unfortunately, not all Prolog programs are independent of order. It is quite easy to write programs in which the order of clauses or of subgoals affects the outcome of evaluation.

fashion. In a case like the above, where the subgoals share no variables at all, the test is redundant and may be replaced by true:

```
goal(A,B) :- ( true subgoal_1(A) & subgoal_2(B) ).
```

Backtracking is permitted but is always sequential; that is, & is ignored during backtracking.

To eliminate conflicts over variable bindings, subgoals can share variables only if the variables are bound and independent. Parsytec provides special predicates to test if variables are bound and independent: `ground()` and `indep()`. In the following example,

```
goal(A,B,C) :-
    ( ground(C) subgoal_1(A,C) & subgoal_2(B,C) ).
```

the variable C is shared between the two subgoals; `ground(C)` will be true if C is bound when the clause is called, and the

parallel evaluation is permitted; otherwise, it reverts to sequential evaluation. A similar predicate called `indep(A,B)` checks that two separate unbound variables have not sneakily been unified prior to the call.

The kind of AND parallelism employed by Parsytec requires very little alteration to the syntax of typical Prolog programs. As an example, here is the parallel version of the QuickSort program from the third edition of *Programming in Prolog* by Clocksin and Mellish:

```
split(H, [A|X], [A|X], Z) :-
    A < H, split(H,X,Y,Z).
split(H, [A|?X], Y, [A|Z]) :-
    H =< A, split(H,X,Y,Z).
split(_, [], [], []).
```

```
qsort([], []).
qsort([H|T], S) :-
```

continued



ML5000
Floppy Disk
Certifier

Are poor quality diskettes ruining your reputation? Introducing the MediaLogic Low Cost Solution

Not all disks are equal

Floppy disks that pass MediaLogic's stringent level of ANSI* tests prove that all disks are not equal. Even if they're tested to your specifications, the quality can vary from lot to lot—from supplier to supplier.

Now there's a low cost easy-to-use tool to test 3 1/2" and 5 1/4" floppy disks during incoming inspection and quality assurance that goes even beyond your own specifications.

The AT based ML5000 is the certifier chosen by OEMs because it was developed specifically for them. Up to four different disk drives can be configured to meet all your certification requirements. A high resolution color monitor displays results in real time and test data can be stored on hard disk for statistical analysis, as you need it. So when you want to evaluate diskette standards for duplication or re-evaluate your own specifications beyond source inspection, the ML5000 is the only certifier that offers more than other certification processes.

More choice of tests

In addition to precise amplitude, resolution, saturation curve and extra/missing pulse, the ML5000 also includes peak shift evaluation, ANSI and ECMA** modulation and overwrite capabilities, allowing you a greater choice of comparisons. These advanced technical capabilities go

*American National Standards Institute
**European Computer Manufacturers Association
AT is a registered trademark of IBM Corp.

beyond what you'd expect. Understanding what's available could make a significant impact on your future media handling operations.

When you think all disks are tested equally—think again. Ask the right questions. What certification methods does your media manufacturer use? Do they evaluate beyond the minimal extra pulse and missing pulse tests? Can returned disks be screened for disk or duplication defects? Technicalities. Lack of them could be the reason you're still getting burned on rejected and returned disks.

More than a floppy disk tester

■ When you add a 3 1/2" or 5 1/4" autoloader to the system you have a volume incoming inspection tester—capable of meeting the many requirements of your customers.

■ With a spin stand, the precision head positioning makes it a formatting and duplication analyzer. Or a production head tester. For head and media testing—it's a quality assurance tool.

■ And when you need to test 2 Mbyte, 4 Mbyte and barium ferrite media—the ML5000 can do it all.

MediaLogic offers many more options for companies who stake their reputation on the quality of the media they select—once we know what you're looking for. Whether you're

running quality assurance programs or adding your label to diskettes you think are tested, it pays to look at the industry standard product for quality control—the MediaLogic ML5000—before you purchase.

But don't take our word for it, ask your media manufacturer if they test to all ANSI standards—and then ask your customers what they prefer.

Contact your local representative and get all the facts about the ML5000 and the family of MediaLogic test products that are built for quality-conscious companies.

Corporate headquarters: MediaLogic Inc.,
310 South Street,
P.O. Box 2258,
Plainville, MA 02762, U.S.A.
(508) 695 2006

Representatives:
U.S.A. WME Systems,
Westlake Village, CA
(818) 706 0845

International Media Service International,
France
(33-1) 30.66.12.95

Japan Jastam Corporation,
Japan
(03) 558 2411

MEDIALOGIC

The most logical choice for
media manufacturers and OEMs
of quality certification

See us at COMDEX
Booth 1944 Bally's

```
split(H,T,A,B),
(true | qsort(A, A1) & qsort(B,B1)),
append(A1, [H|B1], S).
```

This version differs from the original only in the second subgoal of `qsort`. Parsytec reports that this program runs 2½ times faster on four transputers than on one, which means the parallelization is about 63 percent efficient here. QuickSort is not the ideal algorithm for parallel sorting because the two sublists produced by `split` are of arbitrary sizes, and so the parallel processors are not balanced in their work loads; an algorithm that shared the workload more fairly would give a better speedup.

You can simulate OR parallelism in a Parsytec Prolog by giving different names to what would normally be the clauses of a single relation and then invoking them all as AND-parallel subgoals. For example, so long as `X` and `Y` are only used as input (i.e., bound) parameters, `clause1`, `clause2`, and `clause3` will be executed in parallel, as shown:

```
clause1(A,B) :- ...
clause2(A, [B|C]) :- ...
clause3(A, []) :- ...

goal(X,Y) :-
(true | clause1(X,Y) &
 clause2(X,Y) & clause3(X,Y)).
```

This technique can be an effective way of speeding up searches of large Prolog *factbases*, such as you might use in an expert system.

PARLOG

PARLOG is not Prolog, but a parallel-logic programming language with many similarities to Prolog. It employs both AND and OR parallelism and also performs unification in parallel. It renounces backtracking, however, in favor of what is known as *committed choice* between clauses. The clauses of a relation all have an initial *guard computation*. PARLOG tries all the clauses in parallel, and only those whose guards succeed are

candidate clauses for evaluation. In PARLOG, the first candidate is chosen to be evaluated further; the program is said to *commit* to the use of this clause. PARLOG doesn't use backtracking and, therefore, finds only one solution to a goal.

In PARLOG, the guard computation consists of matching the clause head against the goal (as in ordinary Prolog) together with an optional test that can be placed before the clause body (like that in Parsytec Prolog). So, to commit to a clause, a goal must match the clause head, and the test (if present) must be true. To illustrate the syntax, here is the `split` relation from the QuickSort presented above, rewritten in PARLOG:

```
split(H, [A|X], [A|Y], Z) <- A < H : split(H, X, Y, Z).
split(H, [A|X], Y, [A|Z]) <- H = A : split(H, X, Y, Z).
split(_, [], [], []).
```

What was an ordinary subgoal in Prolog (e.g., `A < H`) has become a guard test here. The colon separates the guard calls from the body, and everything to the left of it is the guard computation. The `<-` symbol is equivalent to Prolog's `:-` symbol. PARLOG separates parallel conjunction of subgoals in a clause with a comma and employs the ampersand symbol to force sequential evaluation (exactly the opposite of the Parsytec syntax).

PARLOG handles the problem of binding variables in parallel with a binding mechanism that allows unification to be suspended, and by distinguishing between input and output variables. A PARLOG relation must have a mode declaration that fixes the direction of each of its variables, such as

```
mode split(H?, X?, Y|, Z|).
```

where the `?` means input and the `|` means output. The default mode for variables is input. The variables `H` and `X` carry values into a goal and will normally be bound in a call, while `Y` and `Z` return the answers and will normally be unbound in any call. A typical call might be `split(4, [1,5,6,4,2,7], X, Y)`, with the sublists returned in `X` and `Y`.

The rules for variable binding are as follows:

continued

Satellite Communication MICROSAT II Expansion Board

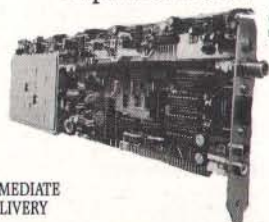

\$700

IMMEDIATE
DELIVERY

- For IBM PC/XT/AT and compatible.
- Satellite data receiver - 9600 baud.
- Satellite bulletin board.
- Satellite video and audio option - Add \$200

PERSONAL SPACE COMMUNICATIONS

707 Johnson Road, Blaine WA 98230
(604)597-6298 TLX 04-508306 FAX (604)597-6214

Circle 252 on Reader Service Card

BIOS SOURCE CODE

The **XT BiosKit** is a 270 page book with a diskette containing source code in C, plus utility programs to help you create a Bios. Now you can have a Bios with documentation for your own applications: modify boot-up, eliminate the keyboard, install security features, etc. Only \$99 complete. The **AT BiosKit** is only \$199, or get both Bioskits for \$279.

— XT-AT HANDBOOK —

The **XT-AT Handbook** is full of hardware and software information in a shirt pocket size book. Over 70 pages covering 38 subjects, including connectors, I/O maps, controller programming, DOS and DEBUG commands, board dimensions, character codes, hard disk drive types, and much more. Only \$9.95 each qty 1-4, five or more, \$5 each.

Annabooks

12145 Alta Carmel Ct. 250, Suite 262
San Diego, California 92128
(619) 271-9526



Circle 27 on Reader Service Card

UNIPRO™ UNIVERSAL PROGRAMMER AND MEMORY/TTL IC TESTER FOR PC/XT/AT



E(EPROM (16K-1MB)
PAL (20 & 24 pins)
BIPOLAR
8741/42/48/49/50 CPU
87(C)5144 CPU
DYNAMIC/STATIC RAM &
TTL TESTER
Option: 4 Socket adaptor

only \$585 complete

Other products available. Individual programmers for E(EPROM (up to 1MB), PAL, BIPOLAR, 8748 series, 8751 series, Memory/TTL Tester, and gang programmers with 4, 8, & 16 sockets. Also industrial quality EPROM Eraser with timer and safety switch is available (erases 30 of 28 pin eeproms at a time).

OEM & Distributor welcome.
10% educational discount

473 Sapena Ct. #24
Santa Clara, CA 95054

Order Line - outside CA
1-800-541-1975

Tech Line (408) 727-6995
FAX (408) 727-6996

XELTEK
VISA
M/C
AMEX

Circle 362 on Reader Service Card



"The Dataworld 286 [12MHz] AT compatible...[is]... the fastest machine of the nine tested in that review [July 1988]." (September 27, 1988).

and ... speed and excellent compatibility... hundreds of dollars less expensive than other AT compatible.



EDITOR'S CHOICE

NOW!
20MHz 286
SI = 22.5

"Marvelously cheap, powerful alternative ... outperformed the other 286's ..."

(October 11, 1988)



DATA-286 12MHz

80286 running at 8/12Mhz, 0/1 wait state
Phoenix BIOS std. (Award BIOS opt.)
512KB of RAM, expandable to 1MB on board
Socket for 80287-8, -10
200W power supply
Real-time clock with battery backup
1.2MB floppy disk drive
Floppy/hard disk controller
(1:1 interleave controllers available)
101-key keyboard with "click"
Mono card w/parallel port (720x348)
TTL monitor with tilt/swivel base

\$1195



Portacom II

80286 running at 8/12Mhz, 0/1 wait state
Phoenix BIOS std. (Award BIOS opt.)
512KB of RAM, expandable to 1MB on board
Socket for 80287-8, -10
Real-time clock with battery backup
1.44MB 3.5" floppy disk drive
20MB, 39ms, self-parking hard drive
102-key keyboard with "click"
Supertwist backlit LCD, 640x400 res.
RGB/monochrome output port
Weighs under 20 Lbs.
1.2MB external floppy drive opt.
Carrying case available

\$1975

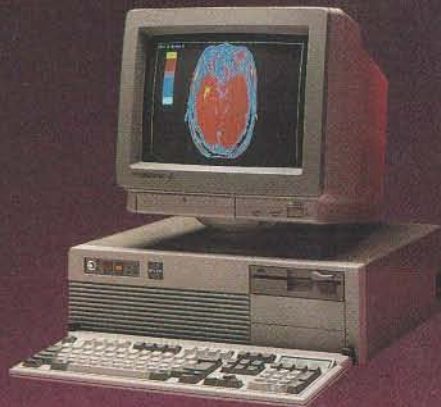

DATA-286 20MHz

80286 running at 10/20Mhz
AWARD BIOS std.
1MB of RAM, exp. to 2MB on board
EMS 4.0 support for memory over 1MB
Socket for 80287
200W power supply
Real-time clock with battery backup
1.2MB floppy disk drive
1:1 interleave floppy/hard disk controller
101-key keyboard with "click"
Mono card w/parallel port (720x348)
TTL monitor with tilt/swivel base

\$1555

COMPLETE 10MHz DESKTOP SYSTEMS FROM \$945.00



Vertical Case

Front panel on/off switch
220W power supply
6 half-height drive bays
Dimensions: 16 3/4"(D) x
7 3/8"(W) x 25 5/8"(H)
Available for 286-/386- models



DATA-386

4.77/6/8/16MHz (20MHz opt.)
1MB of RAM, exp. to 10MB
Phoenix BIOS std. (Award opt.)
220W power supply
1.2MB floppy disk drive
Floppy/hard disk controller
101-key keyboard with "click"
Five 16 and two 8-bit slots
Mono card and monitor **\$1995**



Portacom I

80286 8/12MHz, 0/1 wait
Phoenix BIOS std. (Award opt.)
512K RAM (exp. to 1MB)
200W power supply
1.2MB 5.25" floppy drive
20MB hard disk drive
Supertwist backlit LCD
RGB output port
5 expansion slots
1 parallel, 2 serial ports **\$1875**



Dataworld Keyboard

101-key enhanced layout
L-shaped large return key
Integrated dust cover (paper rest)

\$89



Color-coded key set for WordPerfect available



Prices subject to change. No charge for credit card, check, C.O.D. 30 day moneyback guarantee (Shipping charges non-refundable).

International/overseas inquiries welcome

Calif. 1-800-722-7734 INFO: (213) 695-3777

Non-Calif. 1-800-722-7702 TECH: (213) 699-8250

Monday through Friday, 7 A.M. to 6 P.M. Saturday 9 A.M. to 3 P.M. PST.

3733 San Gabriel River Parkway, Pico Rivera, CA 90660-1495

A PREFERRED COMPUTER SYSTEM



Company Information

Brainware, GmbH
Gustav-Meyer-Allee 25
1000 Berlin 65
West Germany
(030) 463-3058
Inquiry 968.

Parallel Systems Technology Ltd. (Parsytec)
Jülicher Strasse 338
D-5100 Aachen
West Germany
(241) 166000
Inquiry 969.

The PARLOG Group Secretary
Computing Dept.
Imperial College
London SW7 2AZ, U.K.
(01) 589-5111
Inquiry 970.

- No output variables will be bound until after the caller commits to a clause.
- All the input variables are unified in parallel, and only variables in the clause head, not the caller, can become bound. If unification would require binding a variable in the caller, then unification of that variable only will be suspended until another call provides a value for the variable.
- Similarly, guard tests cannot bind any variables in the caller and will suspend if they attempt it.
- Commitment to a clause cannot happen while such an input match or guard test is suspended.
- Once a clause is committed to, then all the output variables are unified with the clause head in parallel with evaluation of the subgoals in the clause body.

Though these rules might sound complicated when expressed in such terms, what underlies them is simply a "one-way traffic" system; inputs can only go in, and outputs can only come out.

This subtle binding strategy provides all the communication and synchronization needed in PARLOG in a way that is quite transparent to the programmer. No rolling back or undoing of variable bindings is ever necessary, because PARLOG variables are never bound more than once; this allows for a small and efficient implementation. Even better, the shared-variable problem ceases to be a problem and becomes an asset. Shared variables now become communication channels between processes, where a process is the evaluation of any subgoal in a parallel conjunction. Moreover, these channels are self-synchronizing (just like those in the Occam programming language), with receivers waiting patiently until a value is ready from the sender. The mode declarations of a program define a data-flow network in which the progress of execution is controlled by the availability of its data.

To try to illustrate how this works, consider a call to the `split` relation embedded in a parallel clause body:

```
mode feeder(X);
mode consumer1(X?).
```

```
mode consumer2(X?).
```

```
....feeder(List), split(4, List,X,Y), consumer1(X),
consumer2(Y).
```

The second input argument of this call to `split` is not bound, so when the call is matched in parallel with the `split` clauses, all three attempted matches will suspend, because each would require binding `List` to something. Hence, the call to `split` cannot commit. Both `consumer1` and `consumer2` suspend, too, because their arguments are of mode input and are unbound. The only part of the evaluation that is not suspended is `feeder`, which must bind its output, `List`, to some value (otherwise it results in deadlock). If the value bound to `List` is a nonvariable, `split` can proceed to commit to a clause and produce its outputs, to be consumed in turn by `consumer1` and `consumer2`. Even if `feeder` binds `List` to a term containing variables (say, `[E|L]`), the input of `split` can still proceed since the binding took place elsewhere, and it would match both `split` clause 1 and 2 with `A` bound to `E` and `X` bound to `L`; now, however, the guard tests will suspend until a nonvariable binding for `E` is supplied from elsewhere (`H` is already bound to 4).

PARLOG enables some powerful programming techniques. For example, a process can produce as its output a list of terms containing variables and then suspend on one or more of these variables. This list acts as a list of messages sent to another process, and when the second process binds one of the variables, it is, in effect, returning a reply to the sender. This method, known as *back communication*, can be used to implement object-oriented message-passing systems very elegantly.

The binding scheme is not completely foolproof, however. Since guards can contain calls to user-defined relations, it's impossible for the language itself to enforce the delayed binding rule. PARLOG provides a primitive called `data(X)`, which causes suspension of binding. You can employ it in writing safe guards, but you might still ignore it and write *unsafe guards* that will bind variables in the caller. Research continues into compile-time and run-time checks for such unsafe guards.

Implementations of PARLOG for Sun workstations and the VAX already exist, and a simulated parallel version for the IBM PC has been demonstrated. Several PARLOG systems for multiprocessors are currently being developed.

The Parallel Debate

Highly parallel Prolog-like languages are likely to be enormously important in the quest for more intelligent computers. It is too soon yet to say which is the best solution for parallelizing Prolog, if indeed any one solution can be the best. Research is still proceeding mainly at the implementation level, and it will be some time before much serious application experience is accumulated. To further complicate matters, the design of parallel-processing hardware is also in its infancy, with no single architecture a clear winner.

The subject is bound to generate plenty of controversy because compromises are involved, and because Prolog purists can be very zealous. For example, is the abandonment of non-determinacy in PARLOG too high a price to pay for its elegant synchronization mechanism? I would say not; some will disagree. Others may judge the synchronization mechanism in CS-Prolog too explicit and nondeclarative. But, then, any language that doesn't generate controversy is probably dead. ■

Dick Pountain is a BYTE contributing editor, a technical author, and a software consultant living in London, England. You can contact him on BIX as "dickp."

SHECOM COMPUTERS

10 MHZ 286

Mono System

- Intel 80286 6/10 MHz clock
- 640K RAM (upgradeable to 1 MEG)
- 1.2 MB 5.25" floppy drive
- 1 parallel - 1 serial I/O port
- 200 watt power supply
- 14" monochrome monitor
- 101 enhanced keyboard
- Real-time clock calendar w/battery
- 2 year warranty
- Oper. sys. w/manual & tutorial

\$1,195

- 1 MEG RAM up-grade. \$260
- For RGB color monitor/card. add \$180
- For EGA color monitor/card. add \$380
- For Multiscan monitor
- With 800X600 contrl card. . . \$480

6-8-10-12 MHZ 286 System

Monochrome

- Intel 80286 6/12 MHz clock
- 1 MEG RAM
- 1.2 MB 5.25" floppy drive
- 1 parallel - 1 serial I/O ports
- 200 watt power supply
- 101 enhanced keyboard
- 14" TTL monochrome monitor
- Real-time clock calendar w/battery
- 2 year warranty
- Oper. sys. w/manual & tutorial

\$1,595

- For RGB color monitor/card. add \$180
- For EGA color monitor/card. add \$380
- For Multiscan monitor
- With 800X600 contrl card. . . \$480

16 MHZ 386

Mono System

- 16 Intel 80386 CPU .1 MEG RAM
- 1.2 MB 5.25" floppy drive
- 40 MB 28 MS (fast) hard drive
- 101 enhanced keyboard
- 1 parallel - 1 serial I/O ports
- 200 watt power supply
- 14" TTL monochrome monitor
- Real-time clock calendar w/battery
- 2 year warranty
- Oper. sys. w/manual & tutorial

\$2,750

- 386 Color System**
- For EGA HI-REZ monitor. \$380
- For Multiscan monitor
- With 800X600 card. \$480

8088-TURBO SYSTEMS

- 5/8 MHz-1 floppy-mono-
clk/cal-256K. \$645
- 5/8 MHz same as above
w/640K. \$785
- 5/10 MHz same as above
+2 floppies. \$895
- 5/10 MHz as above +RGB \$10,900
- 5/10 MHz as above +EGA. \$12,850
- 2 year warranty
- Oper. sys. w/manual & tutorial

TOSHIBA

Laptop Computers

- T1100 plus 5/8 MHz w/640k. . \$1,480
- T1200 as above + 20 MB h.dr. \$ CALL
(New w/backlite twist LCD)
- T3100/20 w/20 MB hard drive \$2,990
- T3200 6/12 MHz 286
w/40 MB. \$3,695
- T5100 8/16 MHz 386
w/40 MB. \$4,795

ONE YEAR WARRANTY

LAZER PRINTERS

- HP Laser Jet. \$1,750
- Panasonic 4450. \$1,595
- Toshi Pagelaser-12. \$2,650

SCANNERS

- Panasonic. \$995
(With contrl card & software)

IBM PS2

- 30-002 10MHz 8086 2 drives. . . \$1,250
- 30-021 10MHz 8086 20mb HD. . . \$1,695
- 50Z-031 10MHz 286 30mb HD. . . \$2,950
- 50Z-061 10MHz 286 60mb HD. . . \$3,400
- 70-E61 16MHz 286 60mb HD. . . \$4,435
- 70-121 20MHz 286 120mb HD. . . \$5,915
- 8503 12" monochrome monitor. . \$ 205
- 8513 12" color monitor. \$ 545
- 8513 14" color monitor. \$ 475
- 8514 16" color monitor. \$1,250
- 5.25" 1.2mb external drive. . . . 255
- Pro-printer II 80col 200cps. . . . 440
- Pro-printer X-24 80col 240cps. . . 650

IBM & PS/2 are registered Trade Marks of International Business Machine Corp. USA

COMPAQ

- Deskpro 286-20 12 MHz 20mb HD. \$2,520
- Deskpro 286-40 12 MHz 40mb HD. . \$3,150
- Deskpro 386-60 20 MHz 60mb HD. . \$5,875
- Deskpro 386-130 20 MHz 130mb HD. \$7,235
- VDU Board. \$ 170
- VGA Board. \$ 525
- 11" Amber or Green Monitor. . . . \$ 230
- 14" Videographic Color Monitor. . \$ 565
- Portable-II/4 8MHz 20mb HD. . . \$2,950
- Portable-III/20 12MHz 20mb HD. . \$4,850
- Portable-386/40 20MHz 40mb HD. . \$6,355
- 512k-2mb upgrade kit for 286. . . . \$ 405
- 1-2mb upgrade kit for 386. \$ 595

Compaq & Deskpro are the registered trade marks of Compaq Computer Corporation USA

CHIPS - CHIPS - CHIPS

- Simm—Sipp—Modules. \$ CALL
- 256-120/100/80ns. \$ CALL
- 1 MEG all speeds. \$ CALL
- 287 Math-Co's all speeds. \$ CALL
- 387 Math-Co 16 & 20 MHz. \$ CALL
- 80387 16 MHz. \$ CALL
- 80387 20 MHz. \$ CALL
- 2754/256 EPROMS. \$ CALL

DRAMS SRAMS ALSO AVAILABLE

COMPUTER ACCESSORY SECTION

TAPE BACKUPS & ADD-ONS

- Irwin-120/5 20 MB XT/AT. \$380
- Irwin-145 20 MB AT Internal. . . . \$515
- Archive 40 MB XT/AT. \$ CALL
- Archive 80 MB Internal. \$ CALL
- Archive 60 MB External. \$ CALL
- 1200 Bauds internal modem. \$ 85
- 1200 Bauds external modem. . . . \$155
- 2400 Bauds internal modem. \$180
- 2400 Bauds external modem. . . . \$240
- MS DOX 3.3 with GWBASIC & manual. . \$105
- OS/2 ver1 oper sys & manual. . . . \$280
- 2mb XT/AT/PS2 Rampage with 512k on. . \$450
- 800x600 Genoa super EGA card. . . . 160
- 800x600 Genoa 5100 super VGA card. . 370
- 1024x768 Genoa 5200 super VGA hi-res. 520
- 13" Technika PGA/VGA/EGA monitor/std. 440
- 15" Idek MGA/PGA/VGA/EGA/CGA monitor. 610
- 13" Sony 1302 multiscan monitor .26m. \$645
- 13" Sony 1303 multiscan monitor .37m. \$510
- 14" phosphor white monochrome monitor. \$145

HARD DRIVES

- ST-225 20mb half height 65ms. . . \$255
- ST-238 30mb half height 65ms. . . \$290
- ST-251-2 40mb hh 40ms. \$395
- ST-251-1 40mb hh 28ms. \$475
- ST-4096 80mb full height 28ms \$750
- Miniscribe 8425 20mb 3.5" 28ms. \$345
- Miniscribe 3053 40mb hh 28ms. . . \$590
- Miniscribe 6085 80mb fh 28ms. . . \$790

FLOPPIES

- Toshi/Fuji/Epson 360 K. \$ 75
- Epson/Nec 1.2 MB. \$ 95
- Toshi/Panasonic 760 K. \$110
- Nec/Toshi 1.4 MB. \$120

CONTROLLER CARDS

- 20/30 MB cntrl card. \$ 50
- 20/30 WD AT C/Card. \$ 90
- 20/30 WD RLL Card. \$ 60
- 20/30 WD Adpt RLL. \$ 55

PRINTERS

Panasonic

- KX1080i 144cps draft/28cps NLQ+cond. mode . . . \$180
- KX1091i 192cps draft/38cps NLQ+cond. mode . . . \$215
- KX1092i 240cps draft/48cps NLQ+cond. mode . . . \$329
- KX1592i 180cps draft/38cps NLQ+cond. mode . . . \$429
- KX1595 240cps draft/51cps NLQ+cond. mode . . . \$459
- KX1524 240cps draft/160cps text+80LQ+cond. . . \$580

TOSHIBA

- P321SL 216 cps draft/72cps LQ 3 fonts built-in. . \$ 95
- P341SL 216 cps draft/72cps LQ 3 fonts built-in . . \$ 625
- P351SX 360 cps draft/120cps LQ 6 fonts built-in . \$1,025
- Color upgrade for P351SX. \$230

(ALL PRINTERS INCLUDE 6' CABLE)

OKIDATA

- ML182+ 180/30cps NLQ. \$ 245
- ML192+ 200/40cps NLQ. \$ 360
- ML292 240/100cps NLQ. \$ 495
- ML390 24-pin 350cps. \$ 510
- ML391 wide carriage. \$ 690

SHECOM COMPUTERS, INC.

22755-G Savi Ranch Parkway
Yorba Linda, CA 92886
FAX (818) 912-5017

Call before you buy and
SAVE! SAVE! SAVE!

Most orders shipped with 48 hours or less

HOURS M-F 8 a.m.—6 p.m. SAT 11 a.m.—3 p.m. PACIFIC TIME

Ask for our Desktop Publishing
CAD/CAM/CAE System Packages &
Apple & Add-Ons & Enhancements

Prices subject to
change without notice

INQUIRIES 714-637-4800

TECH SUPPORT 714-637-5921



SALES ORDERS CALL 1-800-366-4433

PICK BIX BRAINS

... With a 10 Day Trial Membership

If you've thought about joining **BIX** before but weren't sure it was what you needed, now is the time to try it. Because now for a limited time, we're inviting you to try **BIX** for 10 days. If at any time during this 10 day trial period you don't feel **BIX** has made you a more knowledgeable microcomputer user, we'll refund your entire registration fee. You pay only for time spent on the system.* (See log-on instructions for hourly rates).

Explore **BIX** in your home or office. Put its power to work for you and unleash your full microcomputer potential — programming, designing, specifying, researching — and more.

Try **BIX** for 10 full days and see what it can do for you. Explore more than 160 conferences. Access vendor support. Speak to expert consultants. Research new products and systems, and download public domain software.

Prepare yourself for success

It takes a sharp mind and hard work to stay ahead, and having the right tools helps.

Today, you can put one of the most powerful instruments for career advancement to work for you: **BIX**.

- Learn about new products before they hit the market.
- Get quality marketplace feedback on the products you're thinking of purchasing before you invest.
- Research problems and find the solutions that no one else has been able to render.
- Access some of the most advanced public domain software available in the industry.
- Increase your working knowledge of micros to make more confident purchasing decisions and recommendations.

Join **BIX** and arm yourself with the latest in microcomputer-related information

BIX's exclusive *Microbytes* newswire gives you complete, daily, up-to-date computer industry information. You'll gain insight from **BYTE** editors and writers who analyze new products and their potential impact, inform you of the latest mergers and acquisitions, and report late-breaking news from important seminars and conferences.

Talk to colleagues worldwide

You'll stay on top of your company's

business with **BIX's** electronic mail service.

"Talk" to your east coast, west coast — even European — contacts all in the same day.

Or, simply communicate with other **BIX** users worldwide. Share information and ideas privately, or in conference.

Choose any option for online access with a one time \$39 membership fee

- Use MasterCard, VISA or American Express and begin your 10 day trial use of **BIX** right now.
- The 10 day trial also applies if you open an individual pre-paid account on **BIX**. Trial commences once we open your account and notify you.
- Other billing options including qualified corporate accounts are available. (Sorry, our 10 day trial is not available for these accounts.) Call or write **BIX** for details.

Use credit cards for immediate access or call the **BIX** Helpline for information on any other payment option at, 1-800-227-2983 (from U.S. and Canada) 603-924-7681 (in New Hampshire and elsewhere).

Act now! Our 10 day trial offer is subject to cancellation at any time.

*To notify **BIX** that you wish to discontinue service at any time during the trial period, call the **BIX** Helpline, and your entire membership fee will be refunded.

****BIX** can be accessed via Tymnet throughout the U.S. and Canada. For the Tymnet number nearest you, call the **BIX** Helpline or Tymnet at 1-800-336-0149.

†If your local Tymnet number is a toll call you will receive additional charges from your local phone company at their prevailing rate.

††Continental U.S. Tymnet rates. Rates from other areas are available from **BIX**.

BIX is easy to join

To log-on to **BIX**, simply:

Set your computer's telecommunications program for full-duplex, 8-bit characters, no parity, 1 stop bit OR 7-bit characters, even parity, 1 stop bit. Use 300 or 1200 baud.

Call your Tymnet number ** and respond as follows:

Tymnet Prompt	You Enter
Garble or request for "terminal identifier"	a
login:	bix<CR>
BIX logo/name:	bix.038 <CR>

Callers outside the U.S. who have a communicating computer or terminal and a packet switching account with their host country phone system

can reach **BIX** by entering 310690157800. To commence registration, enter the code listed at the **BIX** logo/name: prompt.

After you register, you'll automatically be taken to the **BIX** Learn Conference, an online tutorial that will show you how to begin using the system immediately. Time spent in the Learn Conference is FREE. Complete system documentation will be sent to you within a few days.

Access time will be billed at the following hourly rates.†

Off-Peak Time \$11/hr. (\$9 **BIX**, \$2 Tymnet)††
(7 PM - 6 AM weekdays, all day weekends and holidays)

Peak Time \$20/hr. (\$12 **BIX**, \$8 Tymnet)††
(6 AM - 7 PM weekdays)

BIX

BYTE INFORMATION EXCHANGE

One Phoenix Mill Lane
Peterborough, NH 03458

RAMpak™ for your Compaq!

MicroWay is your best source for the software and hardware you need to get true 32-bit speed out of your 386 machine.

Since many of our users have been having difficulty obtaining memory to upgrade their DESKPROs, we decided to add a 386/20 one megabyte upgrade module to our product line. The RAMpak™ is Compaq compatible and can be used to extend your 386/20 from one to four megabytes. MicroWay's "SlotSaver" combines an mW1167 with a VGA card for the 20 MHz model. We also sell the 25 MHz Weitek 3167 for the DESKPRO 386/25.

Additionally, we have mW1167 slotless numeric coprocessor cards for Acer, ALR, AT&T, Compaq, Dell, Everex, HP, Micronics, NCR, Olivetti, Tandy and Wyse 386 systems. We will soon offer an mW1167 that runs in the Micro Channel of the IBM model 70 and 80.

Dr. Robert Atwell, a leading defense scientist, calculates that NDP Fortran-386 is currently saving him \$12,000 per month in rentals of VAX hardware and software while doubling his productivity!

Fred Ziegler of AspenTech in Cambridge, Mass. reports, "I ported 900,000 lines of Fortran source in two weeks without a single problem!" AspenTech's Chemical Modeling System is in use on mainframes worldwide and is probably the largest application to ever run on an Intel processor.

Dr. Jerry Ginsberg of Georgia Tech reports, "My problems run a factor of six faster using NDP Fortran-386 on an mW1167 equipped 386/20 than they do on my MicroVAX II."

Our NDP compilers and NDP utilities are the key to taking advantage of the two to five-fold increase in speed that the mW1167 provides. The compilers generate mainframe style code, while our utilities simplify ports from either the PC or the mainframe world. A new utility enables our NDP compilers to call HALO 88.

If you are curious about the benefits of the NDP/mW1167 approach, consider the following (price estimates are for complete systems):

Coprocessor	Speed (Flops)	Prices
80287-10	80,000	\$3,000
80387-20	440,000	\$5,000
mW1167-20	2,100,000	\$6,000

When driven by a 32-bit compiler, the mW1167 approaches the speed of a \$600,000 VAX 8650! In fact, many of our users have reported increases in turnaround of 2 to 4 times that of their VAX! Call us for complete details.

32-Bit Compilers and Tools

NDP Fortran-386™ and NDP C-386™ Compilers generate globally optimized, mainframe quality code and run in 386 protected mode under Phar Lap extended MS-DOS, UNIX, or XENIX. The memory model employed uses 2 segments, each of which can be up to 4 gigabytes. They generate code for the 80287, 80387, or mW1167. Both include high speed EGA graphics extensions written in C that perform BASIC-like screen operations.

- **NDP Fortran-386™** Full implementation of FORTRAN-77 with Berkeley 4.2, VAX/VMS and Fortran-66 extensions. \$595
- **NDP C-386™** Full implementation of AT&T's PCC with MS and ANSI extensions. ... \$595

NDP Package Pricing:

387FastPAK: NDP Compiler, Phar Lap and 80387 Coprocessor
16 MHz: \$1299
20 MHz: \$1499

1167FastPAK: NDP Compiler, Phar Lap and mW1167 Coprocessor
16 MHz: \$1695
20 MHz: \$2295

Phar Lap Development Tools \$495
Virtual Memory Extension \$295

NDP Windows™ — NDP Windows includes 80 functions that let you create, store, and recall menus and windows. It works with NDP C-386 and drives all the popular graphics adapters: Library: \$125, C Source: \$250

NDP Plot™ — Calcomp compatible plot package that is callable from NDP Fortran. It includes drivers for the most popular plotters and printers and works with CGA, Hercules, EGA and VGA \$325

NDP/FFT™ — Includes 40 fast running, hand coded algorithms for single and double dimensioned FFTs which take advantage of the 32-bit addressing of the 386 or your hard disk. Callable from NDP Fortran with mW1167 and 80387 support \$250
387FFT for 16-bit compilers \$250

HALO 88 to NDP Graphics Interface — This module enables you to call graphics routines in HALO 88 from NDP Fortran or C \$100

MicroWay® 80386 Support (508) 746-7341

Parallel Processing

Monoputer™

The world's most popular transputer development product runs all MicroWay transputer software using either a T414 or T800. The T800 processor has built-in numerics and provides performance comparable to an 80386 running at 20 MHz with an mW1167. The new 3L Parallel C and Fortran compilers make this an especially attractive porting environment. Can be upgraded to 2 megabytes.

Monoputer with T414 (0 MB) \$995
Monoputer with T800 (0 MB) \$1495

Quadputer™

This board for the XT, AT, or 386 can be purchased with 2, 3 or 4 transputers and 1, 4 or 8 megabytes of memory per transputer. Two or more Quadputers can be linked together to build networks with mainframe power which use up to 100 or more transputers. One customer's application has gone from 8 hours on a mainframe to 16 minutes on a system containing five Quadputers from \$3495

Transputer Compilers and Applications

MicroWay offers Parallel languages for the Monoputer and Quadputer.

Logical Systems Parallel C \$595
MicroWay Occam2 \$495
3L Parallel C \$895
3L Parallel Fortran \$895
MicroWay Prolog Interpreter \$750
mField — A specialty finite element analysis package targeted at transputer networks. Ideally suited to take advantage of the six megaflop speed of the Quadputer ... \$1600
T800/NAG™ (See NDP/NAG) \$895

387BASIC™ — MicroWay's new 16-bit Microsoft compatible Basic compiler generates the smallest EXE files and the fastest running numeric code on the market \$249

Compaq 386/20/25 Add-Ons

RAMpak™ — One megabyte 32-bit memory module fits in Compaq memory slot . . . CALL
mW1167™ — Built at MicroWay using Weitek components and includes an 80387 socket.
mW1167-16 \$995
mW1167-20 \$1595
mW1167/VGA-20 "SlotSaver" \$1995
Weitek 3167 25MHz \$1995
80387-20 \$675
80387-25 \$795

Numeric Coprocessors

8087 \$99
8087-2 \$145
80287-8 \$239
80287-10 \$279
80387-16 \$450
80387-20 \$675
80387-25 \$795
287Turbo-12 (for AT compatibles) \$450
256K 100ns DRAM CALL
256K SIMMS \$119
1 MB SIMMS \$450
(All of our Intel coprocessors include 87Test.)

Intelligent Serial Controllers

MicroWay's AT4™, AT8™, and AT16™ are the fastest 80186-based intelligent serial controllers on the market. They come with drivers for UNIX, XENIX, and PC MOS.
AT4 ... \$795 AT8 ... \$995 AT16 ... \$1295

32-Bit Applications

PSTAT-386 — This mainframe statistics package has been used by government and industry for 20 years. The full version was ported. Requires 4 to 6 megabytes of memory: \$1495

NDP/NAG™ — Features a library of 268 engineering and scientific numerical algorithms. Callable from NDP or 3L Fortran \$895

12 MHz PC Accelerators

FastCACHE-286 12 MHz \$299
SuperCACHE-286 12 MHz \$399
FastCACHE-286 9 MHz \$199

MicroWay

World Leader in PC Numerics

P.O. Box 79, Kingston, MA 02364 USA (508) 746-7341
32 High St., Kingston-Upon-Thames, U.K., 01-541-5466
USA FAX 617-934-2414 Australia 02-439-8400 Germany 069-75-1428

Part 2

A SUPERCOMPUTER

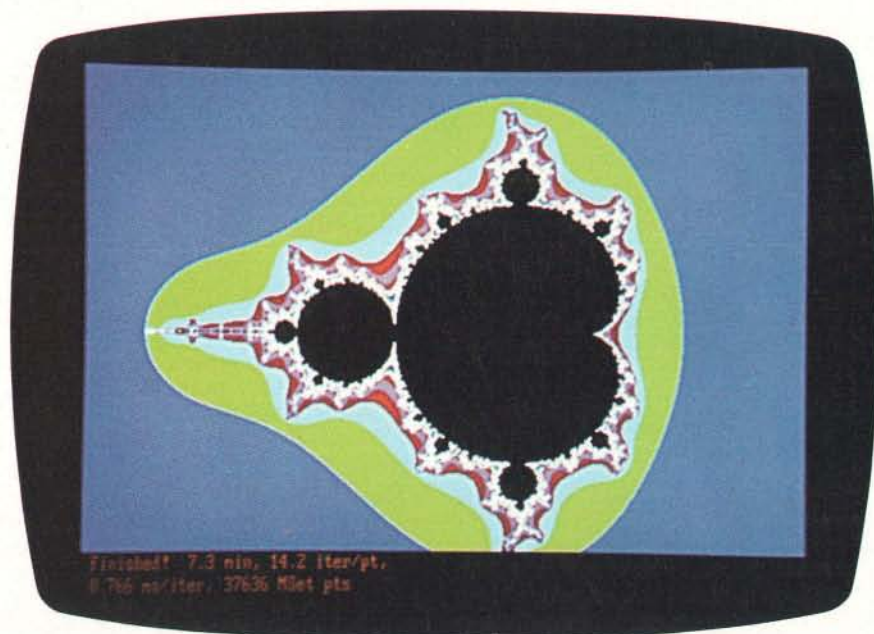

Steve continues the supercomputer project with a look at the Mandelbrot set

Photo 1: The complete Mandelbrot set, as displayed by an EGA monitor (no magnification).

In the first part of this article, I explored the limits of computer performance and described several multiprocessor architectures. In the next two parts, I will describe the Circuit Cellar Mandelbrot engine, a small-scale supercomputer designed to produce the familiar Mandelbrot set images much faster than is possible with an affordable scalar processor.

This installment deals with overall design issues and the algorithms and methods used in the software.

Picking the Problem

Many of the letters that prompted this project detailed the letter writer's favorite fantasy computer. Some of the projects were awesome in scope, featuring multitudes of bit-slice processors, ganged up with megabytes of static RAM and kilobytes of custom microcode!

As I explained last month, the Mandelbrot set calculations are nearly ideal for a multiprocessor because the problem

can be divided among any number of processors and there is no need to communicate between processors during the solution. (I could have tackled North American weather forecasting, but the resulting project would have been out of the reach of nearly everyone.)

But a Circuit Cellar project is a blend of the challenging and the commonplace. It must be challenging enough to be interesting and informative, but it must use relatively commonplace components so that interested readers will be able to afford it. Building a supercomputer out of the latest custom LSI components would certainly be challenging, but few could afford the resulting hardware.

The cost of a multiprocessor is controlled by two major factors: the cost of each individual processor element and the level of communication between them. Element cost is obvious: If a single element costs \$500, how many people would be willing to buy 64 of them? The level of communication determines how many ports each element must have and how complex those ports must be.

The Circuit Cellar Mandelbrot engine uses Intel 8751 processors rather than the 8088 or 80286 chips found in IBM PCs, ATs, and compatibles. The 8751 is similar to the 8031 used in many of my Circuit Cellar projects during the last few years, except that it contains 4K bytes of on-chip EPROM for program storage. Although processors in the 8051 family are often thought of as simple controllers, you are about to see what happens when a bunch of them concentrate on a single task: The engine becomes a beehive of activity!

There are several compelling reasons for choosing a processor from the 8051 family: performance, capability, and price. The performance with a standard 12-MHz crystal is just under 1 million instructions per second because most instructions take one or two cycles of 12 clock periods each. The chip includes a

continued

bidirectional serial port and extensive interrupt support, as well as a reasonably competent instruction set. Finally, a processor element can be a single-chip 8751 or an 8031 with an external EPROM, depending on whether cost or board space is more important; the cost per element ranges from under \$10 to \$40.

Figure 1 shows a block diagram of the

Mandelbrot engine and the connection to the AT controller. The engine can include any number of processor elements between 1 and 255, and performance increases smoothly with the number of elements. The AT connection uses a standard serial port for data transfer, with the port control lines handling handshaking and array resets.

Listing 1: (a) Pseudocode for the Mandelbrot set program kernel. (b) The same code without the SQRT function.

(a)

```
(Given a complex point c and an
iteration limit K)
z = 0+0i
count = 0
while (count <= K) and
  (SQRT (Re(z)^2 + Im(z)^2) < 2.0)
  z = z2 + c
  count = count + 1
end while
```

(b)

```
(Given a complex point c and an
iteration limit K)
z = 0+0i
count = 0
while (count <= K) and
  ((Re(z)2 + Im(z)2) < 4.0)
  z = z2 + c
  count = count + 1
end while
```

The Complex Plane

Photo 1 shows the entire Mandelbrot set displayed on an EGA monitor. You can look at the image as either a mathematical object or the output of a computer program, but you've got to understand both views to know how the Mandelbrot engine works.

Discovered by Benoit Mandelbrot, an IBM Fellow at the Thomas J. Watson Research Center, the Mandelbrot set is probably the best-known example of a fractal figure. Indeed, for many people, "Mandelbrot set" is synonymous with "fractal" and constitutes their only brush with complex numbers.

Mathematically, the Mandelbrot set is a set of points in the complex plane. A complex point *c* is in the Mandelbrot set if the magnitude of *z* in iterative formula

$$z = z^2 + c$$

(starting with $z = 0 + 0i$) remains finite after an infinite number of iterations.

The text box on page 404 gives a brief introduction to complex numbers and arithmetic for those of you who may be a little shaky on the subject. Pay particular attention to the process of squaring a complex number, because it's central to the algorithm.

The criterion for determining whether a given point is in the set should give you pause. No computer can run through an infinite number of iterations in a finite amount of time, so we can never be certain that a point is in the set. The best we can do is show that a given point is definitely not in the set, but that is sufficient to create all the pretty pictures.

It turns out that if the magnitude of *z* exceeds 2.0 after any iteration, it will eventually "blow up" to infinity after some additional number of iterations; therefore, that point is definitely not a member of the Mandelbrot set. If it remains below 2.0 for all the iterations we attempt, the best we can say is that it hasn't blown up yet and that the point may be a member of the set.

The test becomes more reliable with more iterations. For example, if one point blows up after 2 iterations and its neighbor survives 1000 iterations, the second one is probably a Mandelbrot set point. The iteration limit must be the same for all the points in a given image, although the particular value depends on where that image lies in the complex plane.

The algorithm behind the Mandelbrot set is shown in listing 1a. As you can see, despite the foregoing discussion, it's simple enough to fit on only a few lines—the

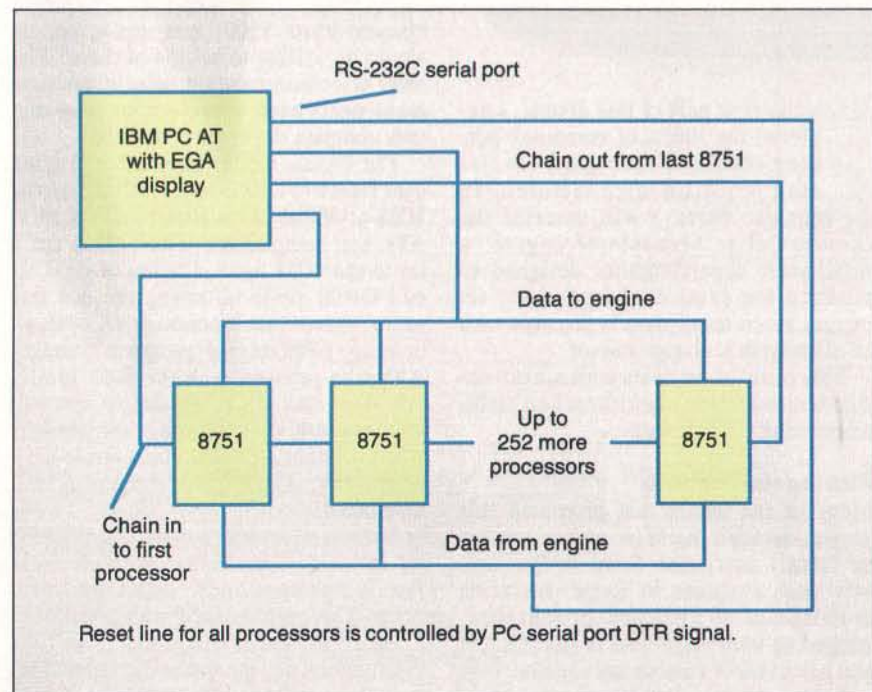

Figure 1: A block diagram of the Circuit Cellar Mandelbrot engine.

sort of program I like.

Figuring the magnitude of a complex number requires a square root, but that is a difficult and time-consuming operation for a microprocessor. Fortunately, we can avoid extracting a square root by simply changing the comparison: Whenever the magnitude exceeds 2.0, the square of the magnitude will exceed 4.0. Listing 1b shows the revised loop.

Determining whether a point is in the Mandelbrot set is simply a matter of evaluating the algorithm in listing 1b until it terminates. If the final count is less than the iteration limit, the point is definitely not in the Mandelbrot set. If the count equals the iteration limit, the point is either in the set or the limit is too low to rule it out; in either case, we assume that the point is in the set.

By convention, all the points in the Mandelbrot set are colored black. The iteration count for the remaining points selects one of the colors available on the display, so the rainbow hues are a direct indication of the size of the iteration count. The blue pixels in photo 1 had the fewest iterations, the green ones had more, and so on up to the bright white pixels adjacent to the central black area marking the set proper.

Floating Points

The center of the image in photo 1 lies at $-0.5 + 0i$ in the complex plane, and the horizontal axis is about 3.6 units long. The EGA was in 640- by 350-pixel mode, so 224,000 separate pixels are shown on the screen. You have to evaluate the algorithm in listing 1 at each one of those points, so you can see why Mandelbrot set images take so long to create.

Because the entire area of the Mandelbrot set must lie within a circle 2.0 units in radius centered on the origin (think about it for a while), the calculations must be done with numbers that can represent fractions. The familiar integer variables used for most purposes in programs simply do not have the range of values needed for the Mandelbrot set.

Because IBM designed the original PC with a socket for a math coprocessor, nearly everyone is familiar with floating-point numbers. In fact, that single design decision may have had more to do with the spread of PCs in the engineering domain than any other; for the first time, floating-point math on a small computer wasn't prohibitively slow.

But it turns out that floating-point numbers are not well suited for the Mandelbrot set calculations, despite the fact that they are quite easy to use. The Mandelbrot engine uses real numbers, to be

sure, but they have a fixed-point representation rather than floating-point. To explain why, I must first detour into floating-point numbers and return via fixed points.

All numeric values within a computer are represented by a fixed number of bits. Remember that a single byte of 8 bits can take on 256 different values, and that 2 bytes can count 65,536 values. The C programming language (and others, as well) allows long integers that have 4 bytes and about 4×10^9 different values. The key idea is that a given number of bits can take on only a fixed number of different values.

The mathematical definition of a real number poses a problem for computer implementations. Between any two real numbers, no matter how close together, are an infinite number of other real numbers. Representing an infinite quantity requires an infinite number of bits, so computers simply can't represent all the real numbers correctly.

Floating-point numbers represent "lots" of real numbers in a "few" bits. The trick is similar to the scientific notation I used just above. Instead of writing 4,000,000,000, I used 4×10^9 and saved quite a bit of space. Each floating-point number has three parts: the mantissa, the sign, and the exponent. The mantissa encodes the significant figures of the real number, the sign tells you if the mantissa is positive or negative, and the exponent represents the magnitude.

Figure 2 shows the floating-point equivalents of some common numbers. Note that the exponent is actually an ex-

ponent of 2 rather than the 10 used in scientific notation. The exponent is selected so that the mantissa is always between 0.5 and 1.0, which you can see by comparing the values for 1, 0.5, and 0.25. Because the decimal point (or, more exactly, the binary point) can be located anywhere in the mantissa, the representation is called floating-point.

Figure 3 shows the IEEE standard format for the floating-point numbers

continued

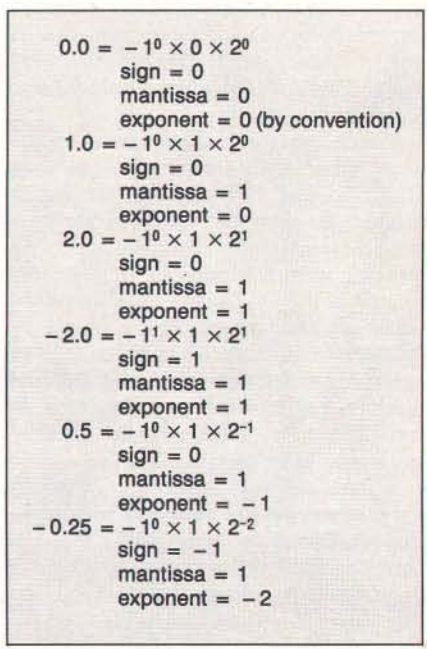

Figure 2: Some common numbers written in the floating-point format.

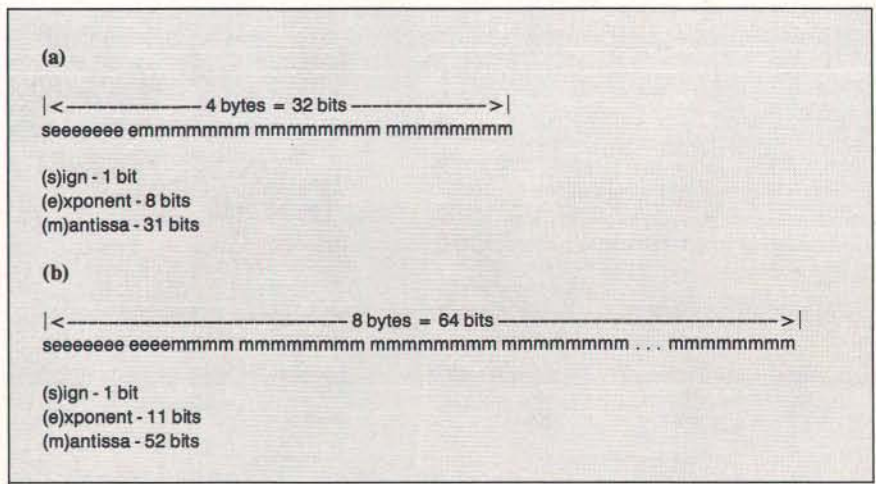

Figure 3: IEEE standard floating-point formats. (a) The format for 4-byte floating-point numbers (float). This representation has a range of $\pm 3.4 \times 10^{-38}$ to $\pm 3.4 \times 10^{38}$ and a precision of six to seven decimal digits. (b) The 8-byte double format, which has a range of $\pm 1.7 \times 100^{-308}$ to $\pm 1.7 \times 10^{308}$ and a precision of 15 to 16 decimal digits.

known to Microsoft C programmers as float and double variables. C programs typically use double variables whenever floating-point numbers are required, but there's a trap for the unwary in this practice.

Many common real-world programming problems are well behaved, in that the real numbers are all within a few orders of magnitude of each other. For example, in electrical engineering, the range of values extends from about 10^{-15} to 10^{12} or so (1 femtofarad to 1 gigahertz, for example). Calculations tend not to exceed these bounds, so programmers can get away with double variables most of the time.

Mandelbrot set calculations, on the other hand, require more precision than even doubles can provide. Photos 2a through 2c show the spike on the left-hand edge of the Mandelbrot set in increasing magnification. As you can see, there's not much change in structure as you zoom in on the set. This is one of the defining characteristics of a fractal figure. The level of detail and overall structure are similar at all magnifications. In some sense, the picture is the same regardless of the magnification.

To contrast this with ordinary objects, try magnifying the period at the end of this sentence by a factor of 10,000. The period is about 0.015 inch across, so the disk would be 150 inches in diameter. The difference in structure between the page and the period should be obvious.

Photo 2c magnifies the tip of the spike by 10^{12} . This is a magnification almost beyond comparison, but here's an analogy: The mean distance between the earth and sun is 92×10^6 miles or 5.83×10^{12} inches. One inch magnified by a factor of 10^{12} is one-fifth of the way to the sun.

Pixels in photo 1 are 0.0056 (3.6/640) units across, while pixels in photo 2c are 5.6×10^{-15} units across. The horizontal coordinates of the left edge of the spike are about 2.0 in both pictures, so you are looking at a single picture that spans 15 orders of magnitude. Recall that float variables have only six digits of precision, and you will begin to see why they would be inadequate.

Because the Mandelbrot set calculations use the results of one iteration as the source for the next pass, there is an inevitable loss of precision in the calculations. This is often called truncation error, because the true value of a real number must be truncated to fit within the available precision. The size of the truncation error increases with the number of iterations and is roughly the loga-

rithm of the iteration count.

The calculations in photo 1 were carried out with an iteration limit of 64, so about two digits ($\log 64 = 1.8$) of precision were lost to truncation near the black areas marking the Mandelbrot set. Many interesting images require hundreds of iterations, so the precision loss can exceed three or four digits.

If the image requires 15 digits of preci-

sion just to represent the coordinates and 4 digits to contain the truncation error, what happens when the program uses float variables having only 6 digits? The answer is painfully obvious: See photo 3. Some of you have seen this effect in your programs, and now you know what caused the failure.

Using double variables doesn't solve the problem. Photo 2a needs about 18

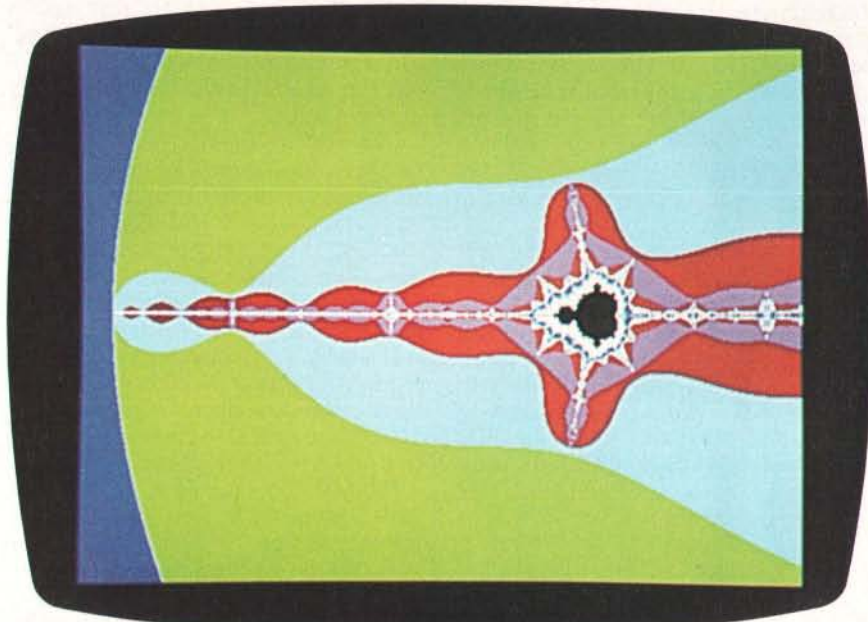

Photo 2a: The "spike" at the left end of the set magnified 10 times.

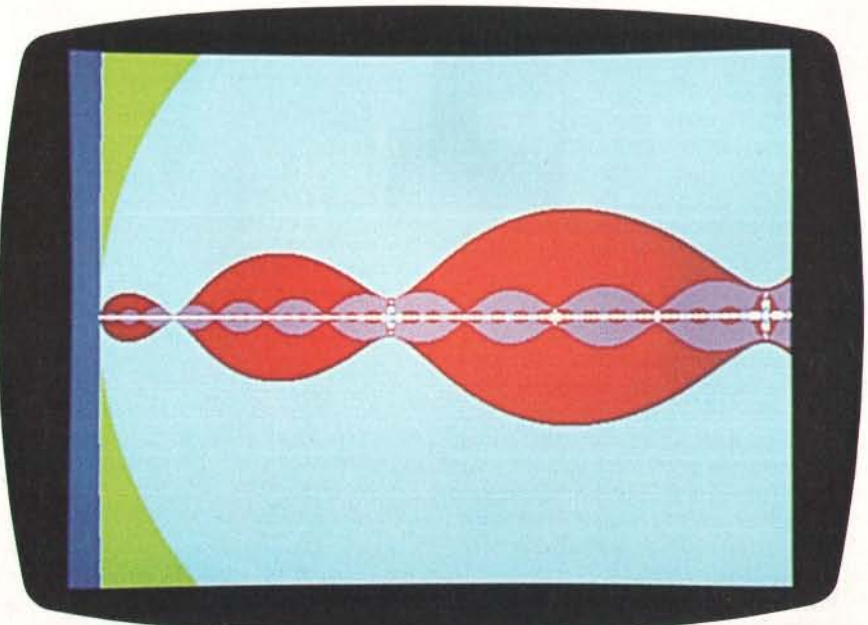

Photo 2b: The "spike" at the left end of the set magnified 100 times.

digits of precision, which is 2 or 3 more than double numbers can offer. What can you do?

Fixed Precision

Although the Mandelbrot set calculations require high precision, they don't require a large dynamic range. The entire Mandelbrot set lies within coordinates of +2.0 to -2.0, and the largest

useful magnitude is only 4.0; some of the exponent bits in float and double numbers are wasted. Being able to represent numbers as large as 10^{308} is no advantage in these calculations.

Figure 4 shows how real numbers are encoded in the Mandelbrot engine. There is no exponent, so there is no way to "float" the binary point in the mantissa. With the binary point in a predeter-

mined location, these numbers are *fixed-point* numbers. The values are stored in two's complement notation, rather than the sign-magnitude used in IEEE floating-point numbers. The complete value occupies the same number of bytes as a double number, but it has at least three more digits of precision.

It turns out that fixed-point number programs are both simpler and faster than floating-point code, simply because there's no need to work with the exponent. Simplicity is particularly important in the Mandelbrot engine, because the code is written in 8051 assembly language.

Fixed-point addition is also easy to understand. Listing 2 shows the 8051 code needed to add two fixed-point numbers, given two pointers to the start of each number. The loop simply adds corresponding bytes and propagates any carries to the left.

It's worth noting that the 8051, despite its Intel heritage, stores 2-byte integers with the high-order byte in the low-order address, so the addition proceeds downward from the high addresses. This is the convention used by Motorola processors and is exactly opposite from the Intel 8088 family. As you might expect, there are conversion routines in the AT driver code to convert from the 8088 convention (low byte first) to the 8051 convention (high byte first).

Although addition is simple, multiplication and division are not. I was able to skip division because the Mandelbrot set calculations didn't need it, but multiplication was essential. The 8051 instruction set includes a multiply that produces a 16-bit product from two 8-bit inputs in only 4 microseconds (μ s), but combining the partial products into the final answer took some tricky coding.

Multiplying two 8-byte fixed-point numbers produces a 16-byte product. A little pencil work will show you that there are 64 multiplies and 56 2-byte additions to combine the partial products. Because each addition can generate a carry into the next byte, there are a considerable number of additional steps to propagate the carries throughout the partial products. Finally, the product has to be aligned so that the binary point is in the right location (if the point can't float, the number must).

Normal extended-precision multiplication routines use a series of nested loops to handle the repetitive calculations. Because this routine is used four times in each iteration, I coded it as a monster macro that creates about 2.5K

continued

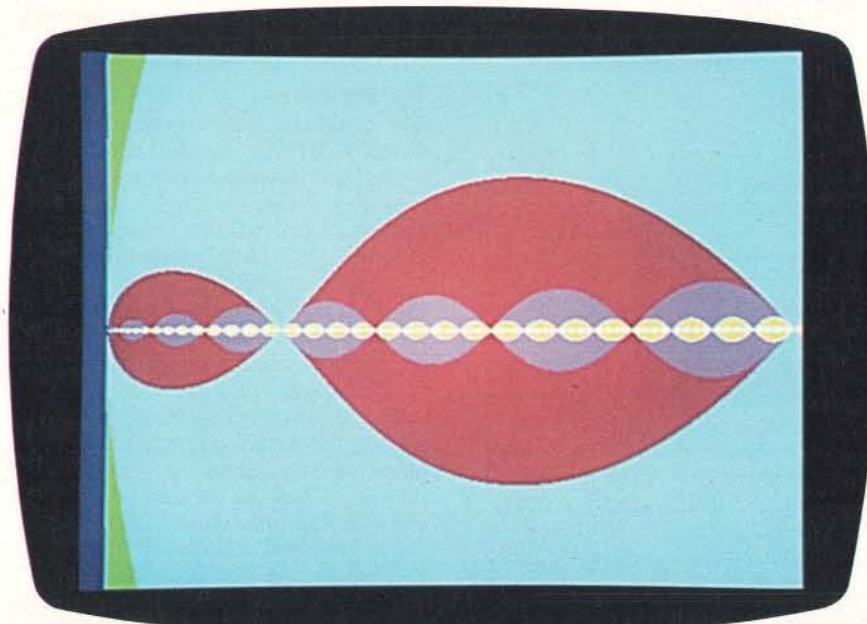

Photo 2c: The "spike" at the left end of the set magnified 10^{12} times.

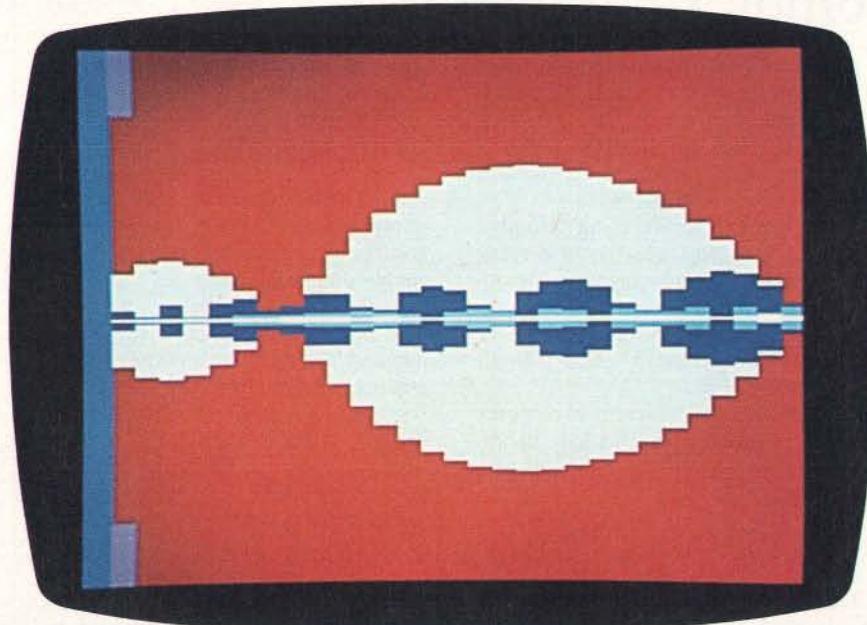

Photo 3: Using float variables while performing the same magnification as in Photo 2c (10^{12} times) makes precision loss due to truncation obvious.

bytes of straight-line code. Space considerations prohibit printing such an incredible bulk here, but it's available for your inspection on the Circuit Cellar BBS.

Because the dynamic range is so low, many of the math routines check their inputs to prevent overflows. For example,

the squaring routine will flag an attempt to square a number greater than 2.0. Unlike most math routines (which signal an error), that overflow simply indicates that the magnitude of a complex number will exceed 4.0, so the Mandelbrot calculations for that case are finished.

Back in the bad old days, when computers filled rooms with racks of vacuum tubes, there were no math coprocessors. A great deal of work went into creating algorithms that could use fixed-point numbers to give useful results. Having to deal with a little of that analysis for this project made me appreciate the early pioneers a whole lot more.

Now that you have an appreciation for the calculations behind the Mandelbrot set, I can describe how the engine actually works.

The Big Picture

Any computer system must have some means to get data in, select and run programs, and get the results back out. A general-purpose multiprocessor (if that isn't an oxymoron) must have extensive I/O facilities and a programming language that supports the array of processors. But, as I said in the beginning, I'm not interested in supporting all the software that's needed for a general-purpose supercomputer.

The Mandelbrot engine is dedicated to solving the iterative formula that computes the Mandelbrot set. That dedication simplifies the process of selecting and running programs: There is but a single program! The Intel 8751 single-chip microcontroller is an ideal processor element, because that program is burned into the on-chip EPROM. Once

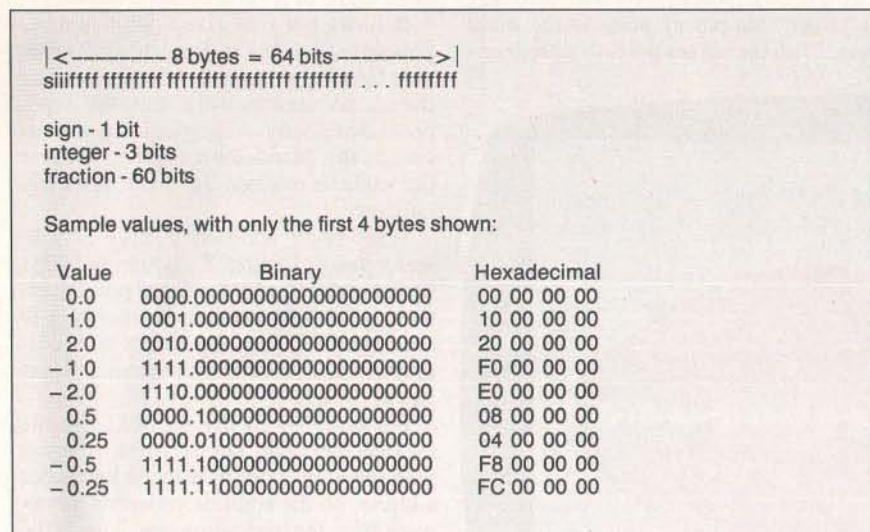

Figure 4: Circuit Cellar Mandelbrot engine fixed-point numbers. Each number occupies 8 bytes of storage and has a range of -8.0 to +7.999... and a precision of 19 decimal digits. In Intel 8051 code, the high-order byte is stored in the lowest address; this is the reverse of the convention used in other Intel processors. Values are stored in two's complement notation. The implied binary point does not occupy a bit location.

Complex Numbers

A complex number is made up of two separate numbers, which, for historic reasons, are called the real and imaginary components. The imaginary component is distinguished by a lower-case *i* either before or after the number. For example,

$$1 + 2i \text{ or } 1 + i2$$

is a complex number with a real part of 1 and an imaginary part of 2. The real and imaginary components are rarely integers, so you'll often see complex numbers written with decimal fractions:

$$1.2345 + 0.4321i$$

Electrical engineers often use *j* instead of *i*, because the symbol for electric current is *i*.

Because complex numbers have two components, they can be plotted on a

plane, with the real component along the *x* (horizontal) axis and the imaginary component along the *y* (vertical) axis. This plane is often referred to as the complex plane because it contains all possible complex numbers.

Adding and subtracting complex numbers is a simple matter of keeping track of the real and imaginary components separately. For example, the sum $(1 + 2i) + (3 + 4i)$ evaluates to $4 + 6i$, while the difference $(1 + 2i) - (3 + 4i)$ becomes $-2 - 2i$.

Forming the square of a complex number is a somewhat trickier operation. Squaring the number $3 + 4i$ proceeds in this fashion:

$$(3 + 4i)^2 = (3 + 4i) \times (3 + 4i) = 3 \times 3 + 3 \times 4i + 3 \times 4i + 4i \times 4i = 9 + 12i + 12i + 16i^2 = 9 + 24i - 16 = -7 + 24i$$

Simplifying $(16i)^2$ to -16 uses the fact that *i* denotes the square root of -1 ,

which is why the imaginary component is called "imaginary"—it isn't one of the numbers we use in the real world.

I'll avoid describing complex division because the Mandelbrot formulas don't need it. If you're interested, your local library probably has a book on complex numbers that shows how division of complex numbers works.

Each complex number has a magnitude that represents the "size" of the number. The magnitude of the complex number *z* is given by the formula

$$\text{Mag}(z) = \{(\text{Re}(z)^2 + \text{Im}(z)^2)\}$$

where $\text{Re}(z)$ and $\text{Im}(z)$ denote the real and imaginary components, respectively. The magnitude is simply the hypotenuse of a right triangle with sides $\text{Re}(z)$ and $\text{Im}(z)$. For example, the magnitude of $3 + 4i$ is $\text{Mag}(3 + 4i) = \{(\text{Re}(3 + 4i))^2 + \text{Im}(3 + 4i)^2\} = \{(3^2 + 4^2)\} = \{(9 + 16)\} = \{25\} = 5$.

programmed, the chip doesn't need a disk drive or tape drive to get started; simply turn on the power and release the reset line, and the program is up and running immediately.

The issues of data communication are not so simply resolved. Once again, though, because we are dealing only with the Mandelbrot set, there is little need for interprocessor communication during the computations. Although the 8751 includes an on-chip serial port, there isn't enough room for a general-purpose network, and there isn't enough space in the EPROM for much of a network operating system.

Refer back to figure 1 to see how the communications are handled. All the 8751 serial inputs are connected together and driven by the AT's serial output. Similarly, all the 8751 serial outputs are connected together to drive the AT's serial input. Of course, there are communication buffers along the way to ensure that the ports are not overloaded.

Each processor has a unique ID number assigned during the initialization sequence, which I'll describe next month. The AT can address a message to any number of processors in the array. If the message goes to a single processor, all other elements ignore the message and continue with their computations.

It's easy enough to control transmissions from the AT to the engine's processors, because there is only one sender on the line. Getting information back without collisions between processors could be very complicated, but another characteristic of the Mandelbrot set calculations came to our rescue.

Despite the exquisite precision required during the enormous number of calculations in each engine, the results can be summed up in 1 or 2 bytes. Polling each processor for its result didn't make any sense, because the necessary handshaking would reduce the effective data rate by at least a factor of 4. Some coordination is required, though, because the processors must return their results in a known sequence.

The "chain-in" line shown in figure 1 organizes the output communications. It daisy chains through all the processors in the engine, so the AT is connected to the first processor, which drives the second, which drives the third, and so on to the last processor, which is connected back to the AT. The key to this is the 8751 program, which will output its result only when its chain-in line is active, then toggle its chain-out line when transmission is complete.

The AT driver program gets ready to

receive a set of results, then toggles its chain-out line. The first processor sends its result, then the second, and so forth through the array. The last processor sends its result and toggles the AT's chain-in line, which tells the AT that all results are complete. The cycle repeats when the AT is ready for the next set.

Because the driver program knows

how the processors were assigned to pixels, it can put the results into the right places. The actual screen painting occurs between sets of pixels to reduce the loop overhead, so the results are metered out of the engine in bursts. The 8751 program will send only 1 byte if the iteration limit is less than 256, which reduces the

continued

Listing 2: The 8051 code to add two fixed-point numbers.

```

;-----
; Add two long integers
; R0 points to the high order byte of the target
; R1 points to the high order byte of the source
; Mashes A, B, and R1
; Returns R0 unchanged
NUMLEN EQU 8 ; bytes per fixed point number
long_add PROC
PUBLIC long_add
MOV A,R0 ; point to end of target
ADD A,#NUMLEN-1
MOV R0,A
MOV A,R1 ; point to end of source
ADD A,#NUMLEN-1
MOV R1,A
MOV B,#NUMLEN ; number to add
CLR C ; set up for loop
L?loop EQU $
MOV A,@R0 ; pick up target
ADDC A,@R1 ; tack on buffer
MOV @R0,A ; drop into target
DEC R0 ; tick pointers
DEC R1
DJNZ B,L?loop ; repeat for all bytes
RET
long_add ENDP

```

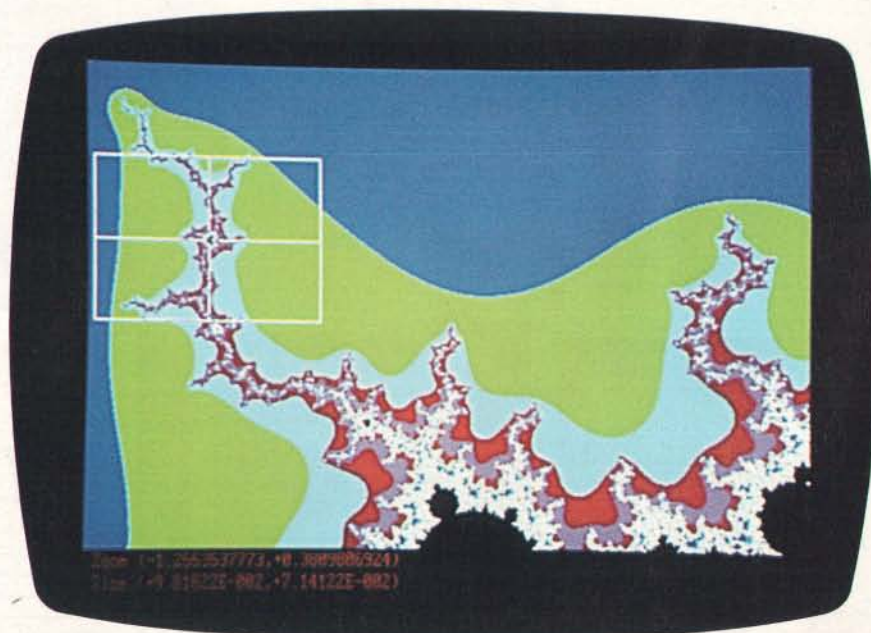

Photo 4: The driver program's zoom box. It is possible for you to home in on an interesting part of the array and magnify it.

data transmission time by a factor of 2 for most images.

You may wonder why I would pick a serial link instead of a parallel port. The answer is simple: It works! A standard RS-232C serial link can send 1 byte in about 380 μ s at 28,800 bits per second. Compared to the time required to compute that byte, the transmission time is small. Only for trivial pictures does the transmission time for the full array approach the computation time.

You might also wonder what effect the daisy chain has on the result throughput. After all, all the down-chain processors must wait on any processor that's not ready when its chain-in signal becomes active. I'll discuss performance next month, but suffice it to say that it's not all that bad. The processors already polled have started on their next set of computations, and the remaining processors are probably still running through the current iterations. Only in the case where one processor hits a point in the Mandelbrot set while all others are outside does this delay become significant.

Because results from the Mandelbrot set calculations are shown on a graphics

display, it's only natural that you should use a graphical means to select which part of the array to view. The driver program creates an overall view of the array, shown in photo 4.

Coming Attractions

Now that you understand how the Circuit Cellar Mandelbrot engine works, I can describe the actual hardware used to build it. In the final part of the series, I'll cover the hardware construction and the AT driver program needed to get the images up on the screen. ■

To receive information about the Circuit Cellar Ink publication for hardware designers and developers, please circle 100 on the Reader Service inquiry card at the back of the magazine.

Special thanks to Ed Nisley and Merrill Lathers for their expert contributions to this project.

Editor's Note: Steve often refers to previous Circuit Cellar articles. Most of these past articles are available in book form from BYTE Books, McGraw-Hill Book Co., P.O. Box 400, Hightstown, NJ 08250.

Ciarcia's Circuit Cellar, Volume I covers articles in BYTE from September 1977 through November 1978. *Volume II* covers December 1978 through June 1980. *Volume III* covers July 1980 through December 1981. *Volume IV* covers January 1982 through June 1983. *Volume V* covers July 1983 through December 1984. *Volume VI* covers January 1985 through June 1986.

There is a multiline Circuit Cellar bulletin board system (running TBBS 2.0M) that supports past and present projects in BYTE and Ink. You are invited to call and exchange ideas and comments with other Circuit Cellar supporters. The 300-/1200-/2400-bps BBS is on-line 24 hours a day at (203) 871-1988.

Steve Ciarcia (pronounced "see-ARE-see-ah") is an electronics engineer and computer consultant with experience in process control, digital design, nuclear instrumentation, and product development. The author of several books on electronics, he can be reached on BIX as "sciarcia."

Your questions and comments are welcome. Write to: Editor, BYTE, One Phoenix Mill Lane, Peterborough, NH 03458.

Limited Edition **BYTE** Collector Prints

#G \$55



Programmable Hardware

#H \$55



Word Processor

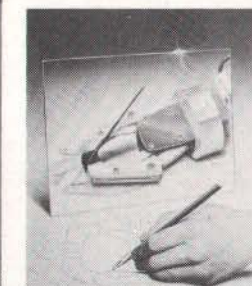

Intelligent Reflections

#A \$90



Technological Breakthrough

#C \$60

Popular *Byte* cover artist Robert Tinney proudly offers these distinctive 16" x 20" Limited Edition Prints. Each is an exquisite, full-color reproduction, and is part of an edition strictly limited to 1000 prints. The museum-quality paper is an acid-free, 100% cotton fiber stock, ensuring brilliance and durability for decades to come. Robert Tinney personally inspects, signs and numbers each individual print, along with a Certificate of Authenticity which verifies the number limit and the destruction of the press plates.

The price of each print is indicated at left; if your order exceeds \$100, deduct 15%. Prints are shipped flat via UPS Blue Label, and carry an unconditional 30-day guarantee. For VISA, MasterCard or AmEx orders, call 1-318-826-3003. Order now!

ORDER FORM

Qty	#	Title	Amount
_____	_____	_____	\$ _____
_____	_____	_____	\$ _____
_____	_____	_____	\$ _____
_____	_____	_____	\$ _____
If your order exceeds \$100, deduct 15%.			\$ _____
\$4 postage & handling (\$25 overseas).			\$ _____
Total			\$ _____

I have enclosed a check or money order to Robert Tinney Graphics. (Must be drawn on a U.S. Bank, no foreign collection, please.)

Bill me VISA MasterCard American Express account

Card No.: _____ Expires: _____

Name: _____

Address: _____

City: _____ State: _____ Zip: _____

Country: _____

Send a brochure showing your other prints.



ROBERT TINNEY GRAPHICS
P.O. Box 778
Washington, LA 70589

The \$4,500⁰⁰ Sun™/Apollo™/VAX™

(Only faster—and it's all yours!)

Suddenly your PC/XT/AT has the computing power of a mini or technical workstation.

Definicon's coprocessors are single-board computers that slip into one expansion slot of any IBM-compatible—and turn it into your personal, desktop, 32-bit *power* machine. You can choose clock speeds from 12.5 to 25 MHz, with 1 to 16 megabytes of RAM.

That means the exact, cost-efficient power you need—for single units or whole systems—at prices from only \$1,349 to \$15,920.

We also offer boards for parallel processing and graphics. Plus software. And all combine the user-friendly MS-DOS advantages of your PC with supercharged power that's yours alone, shared with no one.

If you, or those you manage, have a voracious need for computing power, you *must* get the whole story.

Call Darby Liddin at Definicon right now.

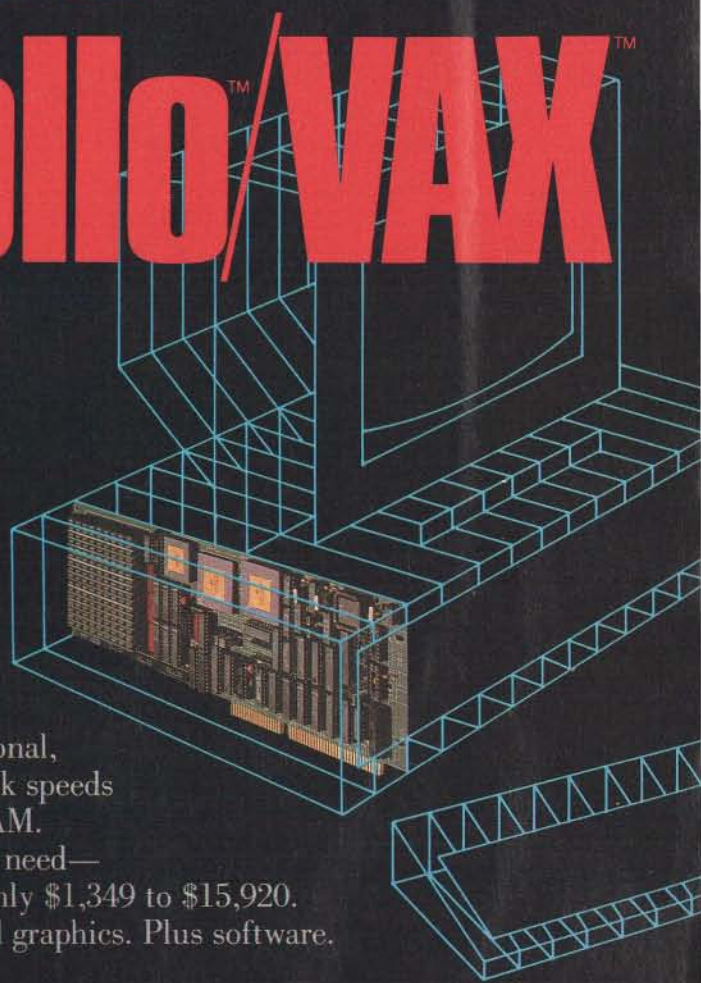

DEFINICON

Get Aboard Tomorrow

Definicon Systems, Inc.
1100 Business Center Circle
Newbury Park, CA 91320
(805) 499-0652

UK: 1-498-0704 France: 1-69-307000 Germany: 49-89-572062

Circle 96 on Reader Service Card (DEALERS: 97)

PolyAWK™ – The Toolbox Language.™

MS-DOS For C, Pascal, Assembly & BASIC Programmers. OS/2

We call PolyAWK our "toolbox" language because it is a general-purpose language that can replace a host of specialized tools or programs. You will still use your standard language (C, Pascal, Assembler or other modular language) to develop applications, but you will write your own specialized development tools and programs with this versatile, simple and powerful language. Like thousands of others, you will soon find PolyAWK to be an indispensable part of your toolbox.

A True Implementation Under MS-DOS & OS/2

Bell Labs brought the world UNIX and C, and now professional programmers are discovering AWK. AWK was originally developed for UNIX by Alfred Aho, Richard Weinberger & Brian Kernighan of Bell Labs. Now PolyAWK gives MS-DOS programmers a true implementation of this valuable "new" programming tool. PolyAWK fully conforms to the AWK standard as defined by the original authors in their book, *The AWK Programming Language*.

A Pattern Matching Language

PolyAWK is a powerful pattern matching language for writing short programs to handle common text manipulation and data conversion tasks, multiple input files, dynamic regular expressions, and user-defined functions. A PolyAWK program consists of a sequence of patterns and actions that tell what to look for in the input data and what to do when it's found. PolyAWK searches a set of files for lines matched by any of the patterns. When a matching line is found, the corresponding action is performed. A pattern can select lines by combinations of regular expressions and comparison operations on strings, numbers, fields, variables, and array elements. Actions may perform arbitrary processing on selected lines. The action language looks like C, but there are no declarations, and strings and numbers are built-in data types.

Saves You Time & Effort

The most compelling reason to use PolyAWK is that you can literally accomplish in a few lines of code what may take pages in C, Pascal or Assembler. Programmers spend a lot of time writing code to perform simple, mechanical data manipulation — changing the format of data, checking its validity, finding items with some property, adding up numbers and printing reports. It is time consuming to have to write a special-purpose program in a standard

PolyAWK Comes With The Definitive Book On AWK...



\$199 OS/2

\$ 99 MS-DOS

Requires MS-DOS 2.0 or above or OS/2 & 256K RAM

When you order PolyAWK you receive a copy of *The AWK Programming Language* written by the authors of the original UNIX-based AWK. The book begins with a tutorial that shows how easy AWK is to use, followed by a comprehensive manual. Because PolyAWK is a complete implementation of AWK as defined by the book's authors, you will use this book as the manual for PolyAWK.

You can purchase PolyAWK and the book, *The AWK Programming Language* for \$99 (MS-DOS) or \$199 (OS/2). Purchase both the MS-DOS and OS/2 versions for \$249 and save \$49 (includes one book). If you already have the book, you can order PolyAWK software only for \$85 (MS-DOS) or \$185 (OS/2), which is \$14 off the regular purchase price. (The book serves as the User's Manual, so you should already have a copy of the book if you are ordering the software only.)

PolyShell Bonus For MS-DOS!

PolyShell gives you 57 of the most useful UNIX commands and utilities under MS-DOS in less than 20K. You can still use MS-DOS commands at any time and exit or restart PolyShell without rebooting. MS-DOS programmers — discover what you have been missing! UNIX programmers — switch to MS-DOS painlessly! PolyShell and PolyAWK are each \$99 when ordered separately. Save \$50 by ordering the PolyShell + PolyAWK combination package for \$149 (MS-DOS only). *Not copy-protected.*

30-Day Money Back Guarantee

Credit Card Orders:

1-800-547-4000

Ask for Dept. BYT

Send Checks and P.O.s To:

POLYTRON Corporation

1700 NW 167th Place, Beaverton, OR 97006

(503) 645-1150 — FAX: (503) 645-4576

language like C or Pascal each time such a task comes up. With PolyAWK, you can handle such tasks with very short programs, often only one or two lines long.

Prototype With PolyAWK, Translate To Another Language

The brevity of expression and convenience of operations make PolyAWK valuable for prototyping even large-sized programs. You start with a few lines, then refine the program, experimenting with designs by trying alternatives until you get the desired result. Since programs are short, it's easy to get started and easy to start over when experience suggests a different direction. PolyAWK has even been used for software engineering courses because it's possible to experiment with designs much more readily than with larger languages. It's straightforward to translate a PolyAWK program into another language once the design is right.

Very Concise Code

Where program development time is more important than run time, AWK is hard to beat. These AWK characteristics let you write short and concise programs:

- The implicit input loop and the pattern-action paradigm simplify and often entirely eliminate control flow.
- Field splitting parses the most common forms of input, while numbers and strings and the coercions between them handle the most common data types.
- Associative arrays use ordinary strings as the index in the array and offer an easy way to implement a single-key database.
- Regular expressions are a uniform notation for describing patterns of text.
- Default initialization and the absence of declarations shorten programs.

Large Model Implementation

PolyAWK is a large model implementation and can use all of available memory to run big programs or read files greater than 64K.

Math Support

PolyAWK also includes extensive support for math functions such as strings, integers, floating point numbers and transcendental functions (sin, log, etc.) for scientific applications. Conversion between these types is automatic and always optimized for speed without compromising accuracy.

POLYTRON

High Quality Software Since 1982



EMBEDDED LANGUAGES

ExTalk allows users to extend the capabilities of your application programs

Though the term "embedded languages" suggests a subject explored only by programmers, the topic is closer to home than you might think. Have you ever created your own custom log-on routine with your favorite communication package's script language? Or written a macro for your word processor to remove superfluous spaces between words? Script and macro programs are both embedded languages.

You could think of embedded languages as miniature programming environments within an application that permit the user to customize and extend the application beyond what its designers had anticipated. There are other examples of embedded languages (so called because the language is *embedded* within the larger application); for example, some database packages include embedded languages so extensive that most of your work with the package actually involves programming on a par with "traditional" high-level language development.

In this article, I am going to describe a simple language that I have designed that you can embed in your application program to provide a facility for users to extend the application. I call the language ExTalk. ExTalk is a fairly standard Algol-like procedural language with the expected control structures, like IF...THEN...ELSE, WHILE...DO, BEGIN...END, and functions with arguments. It also supports object-oriented programming with message passing and inheritance. If you've had experience with C, Pascal, or any of the modern versions of BASIC, then you'll most likely

be right at home with ExTalk's syntax.

In addition to providing normal programming constructs, ExTalk has a facility for extending the language with functions that are unique to the application it is embedded in. So, for example, if you're writing the world's next great CAD program, a user could call on this facility to access functions already built into your package for drawing polygons on the screen. Or perhaps you're building a communications program and you've already designed the routines for handling the Kermit protocol; ExTalk's extension capabilities would allow a user to call your Kermit routines from a communication's script to create a custom file-transfer program.

What's Inside

ExTalk consists of a compiler that translates ExTalk source programs into code for a virtual machine. This virtual machine code is then executed by an interpreter. This approach simplifies the process of porting ExTalk to other machines that support the C language (ExTalk is written entirely in C). It will work with any compiler that is compatible with K&R C. (If you've got the BDS C compiler, you're probably out of luck.) To add ExTalk to an application, you simply compile ExTalk's compiler and interpreter and link them into your application program.

As I mentioned earlier, ExTalk's syntax should be familiar to most programmers. An example of ExTalk code for the factorial function is shown in listing 1. This is the standard recursive implementation of the factorial function. Notice that there are no type declarations; in ExTalk, data is typed, not variables. Consequently, any variable or function parameter can take on any type of value.

To use this function, you need to compile it into *bytecode*, the instructions that the ExTalk interpreter understands. You compile the function through the ExTalk compiler, which stores the resulting code

as the value of the function name symbol—*factorial*, in this case. Listing 2 shows the code that the ExTalk compiler produces for the *factorial* function. (I've added comments to clarify the code.)

By careful examination of the code, you have probably deduced that the ExTalk virtual machine is a stack machine (see the text box "Inside ExTalk" on page 412). That is, instead of registers, the EVM's primary operating storage during instruction execution is a FIFO stack (see figure 1 for a diagram of the virtual machine's architecture).

Instructions always operate on the top few stack entries. For instance, the MUL instruction multiplies the top stack entry with the second stack entry and replaces both with the result. The LIT instruction moves a value from an array of literals associated with the compiled function to the top of the stack.

Each of the bytecode instructions consists of an op-code byte, possibly followed by one or more extension bytes. The MUL instruction takes just a single byte while the BRF (branch on false) instruction takes 3 bytes—one for the instruction, and two extension bytes to encode a 16-bit offset from the base of the function as the target for the branch.

The bytecode interpreter simply fetches each instruction and simulates the effect of that instruction, thereby creating the virtual machine. Some instructions move values to and from the stack; others load or store values into

continued

Listing 1: ExTalk listing for a function that computes the factorial of a number n.

```
Function factorial(n)
  If n = 0
    Then 1
    Else n * factorial(n - 1)
```

global symbols or function arguments.

You call the ExTalk bytecode interpreter with a single argument—specifically, the name of the function to execute. The function itself must not take any arguments, and its return value is discarded upon completion. The interpreter starts by creating a dummy stack frame for the named function and then transferring control to the function. If the function is compiled bytecode, the interpreter enters the instruction fetch cycle. If it is an extension function (which I'll describe in a moment), the

interpreter then calls the corresponding C function.

Extending the Language

For ExTalk to be useful as an embedded language, the developer must be able to extend it with functions specific to the application you decide to embed it in. You could do this by adding op codes for each application-specific function you want ExTalk to support, and then writing the additional C routines the bytecode interpreter will need to handle these new op codes. This has the advantage

that the interpreter will not require special code to dispatch to the application functions. However, it has the disadvantage that only a limited number of op codes are available (256, since ExTalk has an 8-bit op code), and ExTalk already uses some to define its rudimentary instructions.

I have chosen a different tack. Instead of adding op codes, I have introduced a new data type for application functions. When the bytecode interpreter executes a CALL instruction, it looks at the data type of the procedure being called. If the procedure is a compiled bytecode procedure, it invokes the interpreter recursively to execute the bytecodes that are associated with the called function. If the procedure is an application function, the bytecode interpreter retrieves the address of the C language procedure that handles the application function and calls that function. Since the C procedure has access to the EVM's stack, you can use that stack to pass arguments to and from ExTalk and the application functions.

An example of an application-specific function appears in listing 3. Since I wrote ExTalk on a Macintosh computer, this example shows how to draw a line in a Macintosh window.

The ExTalk compiler generates code that pushes the arguments on the stack from left to right. Since the stack grows from high memory to low memory, the arguments appear in reverse order on the stack. When an extension function is called, the last argument is on the top of the stack (in the stack element array `sp[0]`), and each preceding argument is at a higher location in the stack (the next-to-last argument is in `sp[1]`, and so on). Since the `LineTo` function takes two arguments, the first is in `sp[1]` and the second is in `sp[0]`.

First, the routine calls `chktype` to check the types of the two arguments. For `LineTo`, both arguments must be integers. Next, `LineTo` fetches the values of the arguments from the stack. Since ExTalk allows arguments of any type to be passed to functions, each value on the stack contains both a type field and a value field. The `chktype` macro checks the type field of the specified stack entry. When a routine fetches the value of a stack entry, it uses the value field. The expression `sp[1].v.v_integer` fetches the integer value of the second element on the stack.

After fetching the values of the two arguments, `LineTo` saves the current port, sets the port to the graphics window, and

continued

Listing 2: ExTalk virtual machine bytecode for the program in listing 1.

```

PUSH      ; make room on the stack
ARG 00    ; move argument zero to the stack
PUSH      ; make room on the stack
LIT 02    ; move literal 2 to the stack (0)
EQ        ; compare the top two stack entries
BRF L1    ; branch if they are not equal
LIT 03    ; move literal 3 to the stack (1)
BR L2     ; branch around the else clause
L1 ARG 00 ; move argument zero to the stack
PUSH      ; make room on the stack
VAR 04    ; move value of FACTORIAL to the stack
PUSH      ; make room on the stack
ARG 00    ; move argument zero to the stack
PUSH      ; make room on the stack
LIT 05    ; move literal 5 to the stack (1)
SUB       ; subtract the top two stack entries
CALL 01   ; call the FACTORIAL function
MUL       ; multiply the top two stack entries
L2 RETURN ; return from FACTORIAL
    
```

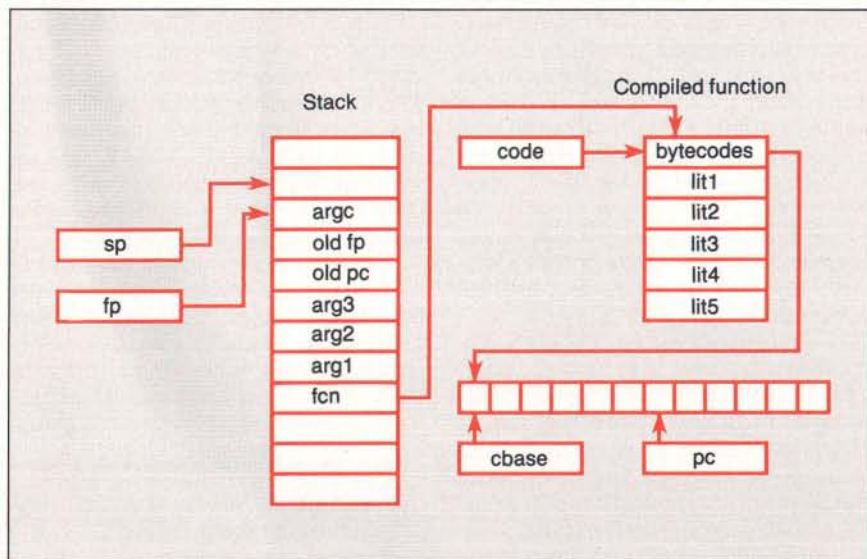

Figure 1: Inside the ExTalk virtual machine. The stack-pointer pseudoregister is `sp`, and the frame-pointer pseudoregister is `fp`. The pseudoregister `code` points to the current compiled function and is used for access to the literals. The `cbase` pseudoregister points to the base of the string of bytecodes associated with the current function, and `pc` points to the op code of the next bytecode instruction to execute.

Turn your favorite
C compiler into a
powerful database
manager with the

C/Database Toolchest



The **C/Database Toolchest™** adds sophisticated file management functions to your Power C™, Turbo C®, QuickC®, or Microsoft® C compiler. With the **C/Database Toolchest™**, your data requires much less disk space than with programs like dBASE®, and you can access your data much faster. Of course the full power of C provides you with an unlimited amount of programming flexibility.

The **C/Database Toolchest™** includes three major components:

- 1) An advanced B+tree library gives you instant access to your data.
- 2) A high-level ISAM library provides you with an easy-to-use C interface, and

3) A complete database manager (with C source code included) shows you how to create impressive applications.

You also receive a comprehensive 350 page manual and a utility for converting dBASE® files.

The **C/Database Toolchest™** supports features that you'd expect to find only in products costing ten times as much. Advanced features include variable length records, variable length keys, multiple keys per index, and multiple indexes stored in a single file. Your data files can contain an unlimited number of records, and each record can be as large as 32K bytes in length.

About the only thing that the **C/Database Toolchest™** doesn't do is cost you a lot of money. We've kept our price low so you can manage your budget as easily as your data.

Now Only \$19.95!

Order now by calling our toll free number or mail the coupon to:

Mix Software
1132 Commerce Drive
Richardson, TX 75081

1-800-333-0330

60 Day Money Back Guarantee

Not Copy Protected ■ Royalty Free

For technical support, please call:

1-214-783-6001



Order Coupon

Name _____
Street _____
City _____
State _____ Zip _____
Telephone _____
Paying By Money Order Check
 Visa MC AX Disc.
Card# _____
Exp. Date _____
Disk Size _____ 5 1/4" _____ 3 1/2"

Qty.	Product	Price	Subtotal
—	C/Database Toolchest.....	\$19.95	_____
—	C/Database Library Source..	\$10.00	_____
	B+tree & ISAM library source code		_____
	Add Shipping (\$5 USA, \$20 Foreign).....		_____
	Texas Residents Add 8% Sales Tax.....		_____
	Total Amount of Your Order.....		_____

Inside ExTalk

Following is a list of the instruction set for the ExTalk virtual machine. I've grouped the instructions based on operation and provided a brief description of each.

Branch Instructions:

BRT *nnnn* Branch on true
BRF *nnnn* Branch on false
BR *nnnn* Branch unconditionally

The branch instructions BRT, BRF, and BR take a 16-bit offset in the 2 bytes following the op-code byte. If the branch is taken, the new PC is determined by adding the offset to the base address of the bytecode string.

Constants and Variables:

LIT *nn* Load literal
VAR *nn* Load a variable value
SET *nn* Set the value of a variable

The LIT, VAR, and SET instructions take an 8-bit offset into the literal vector in the byte following the op-code byte.

Subroutine and Messaging:

CALL *nn* Call a function
SEND *nn* Send a message to an object
SENDSUPER *nn* Send a message to superclass of self
RETURN Return from a function

The CALL, SEND, and SENDSUPER instructions take the number of arguments in the byte following the op-code byte.

Arguments, Instances, and Class Variables:

ARG *nn* Load an argument value
ASET *nn* Set an argument value
IVAR *nn* Load an instance variable value
IVSET *nn* Set an instance variable
CVAR *nn* Load a class variable value
CVSET *nn* Set a class variable

The ARG, ASET, IVAR, IVSET, CVAR, and CVSET instructions take the argument, instance variable, or class variable number in the byte following the op-code byte.

Miscellaneous:

TRUE Load top of stack with true
FALSE Load top of stack with false
PUSH Push nil onto stack
NOT Logical negate top of stack
ADD Add top two stack entries
SUB Subtract top two stack entries
MUL Multiply top two stack entries
DIV Divide top two stack entries
REM Remainder of top two stack entries
BAND Bitwise AND of top two stack entries
BOR Bitwise OR of top two stack entries
BNOT Bitwise NOT of top stack entry
SHL Shift second stack entry left by first
SHR Shift second stack entry right by first
LT Compare top two entries for less than
EQ Compare top two entries for equal to
GT Compare top two entries for greater than

case-sensitive. It considers the symbols LINETO and LineTo to be identical.)

A typical application would probably contain several hundred application-specific functions. A spreadsheet might have functions for computing sums and averages of ranges of cells, while a communications program might have functions for controlling the modem and sending and receiving strings of characters. These functions could be implemented either as extension functions, like LineTo above, or as functions in ExTalk itself built on top of the lower-level extension functions, as I did with the square function.

In either case, ExTalk, along with the application-specific extension functions, gives the user much more control over the behavior of the application than would be possible without an extension language. The user can add new functions to the application without having to wait for the next release of the application. Thus, you give the user much more flexibility in tailoring the application to suit his or her needs without having to resort to the kitchen sink approach.

The ExTalk Compiler

The ExTalk compiler reads a text file containing ExTalk source code and sends the compiled result to memory. You call the compiler with a single argument that is simply the name of the file to compile. Functions are compiled, and the resulting function is stored as the value of the function name symbol.

The compiler consists of a lexical scanner, a parser, and a code generator. It makes a single pass over the source code. The parser is an ordinary recursive descent type, and it generates bytecodes during the parse rather than building an intermediate representation of the program. Listing 5 shows the part of the compiler that handles the "+" and "-" operators.

First, ExTalk calls the `do_expr3()` function to parse and generate code for the expression to the left of the operator. Then, using the `token()` function, it fetches the next token to see if it is either a "+" or a "-." If it is, the program generates a PUSH instruction to reserve space on the run-time stack for the second operand and then calls `do_expr3()` to parse the expression to the right of the operator. After parsing the right-hand expression, ExTalk generates the instruction that will perform the operation (addition or subtraction) on the two values that are left on the top of the stack.

continued

draws the line. Finally, the routine restores the saved port (using the `SetPort()` routine), pops the arguments off the stack, stores the return value on the top of the stack, and exits.

To make the LineTo function available to ExTalk programs, you must enter it into the symbol table. You do this with the following:

```
add_function("LINETO",
            ex_lineto);
```

This adds the symbol LINETO to the symbol table and sets its value to be the address of the C function `ex_lineto`. Now, all references to the symbol LINETO will refer to this extension function.

You can now use the LineTo function in ExTalk just like any built-in function. Listing 4 shows an ExTalk function that draws a square using the LineTo function and the MoveTo function, which is defined using the same method I showed with LineTo. (Notice that ExTalk is not

I N T R O D U C I N G

Incra

THE INCREMENTAL ASSEMBLER DEVELOPMENT ENVIRONMENT

a Revolution in Assembler Programming

A complete, integrated macro assembler development environment for the 8086 family of processors under DOS. Including a powerful window-oriented source debugger, syntax checking editor, fast linker, and the FIRST INCREMENTAL ASSEMBLER.

Other assembler development cycles look like this:

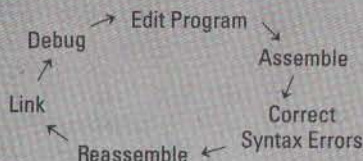

Cycle Time: 2-20 minutes (or more)

The INCRA development cycle looks like this:

Edit ↔ Debug

Cycle Time: Less than 1 Second!

With other systems, the development cycle for large programs can take several minutes involving a lot of tedious hopping from one program to another. The INCRA Assembly development environment is completely integrated, everything you need to develop assembler programs or routines for programs in other languages, is available at the touch of a key. With INCRA you go from program entry and editing to debugging instantly because the INCRA assembler is INCREMENTAL. It updates the executable code as soon as you change the source – in milliseconds. And the powerful INCRA debug window is always available at the push of a key to trace through the program. If you find a mistake, just flip to the editor and correct it, then flip to the debugger and continue testing.

The INCRA editor checks your assembler syntax as you enter, giving intelligent error messages that make it clear what was wrong and how to fix it – you never have to worry about waiting 5 minutes for a program to assemble, only to find you have to do it all over because you forgot to put in a comma! INCRA

also contains a fast, integrated linker that can quickly pull in procedures from other modules and libraries at the push of a button. The INCRA incremental assembler works just as well on linked programs as on single modules, so you can develop large, multi-module programs, and mixed language programs with ease. And with INCRA, macros expand as soon as you enter them, no need to wait for assembly to see if the macro expanded the way you thought it would! If there's a mistake, just edit the macro call, and the macro will immediately reflect the changes.

If you're a serious programmer working with assembler, INCRA's power and speed will make your life easier. If you're just learning assembler, INCRA's ease of use will make it exciting and fun!

If you've always thought of assembler programming as slow, time-consuming, complicated and tedious, wait till you get your hands on INCRA. You'll be saying assembler development with INCRA is Fast... **\$180⁰⁰** Efficient... FUN!

*If you do any assembler programming at all...
Incra is the tool to use.*

SYSTEM REQUIREMENTS: IBM® PC OR COMPATIBLE WITH 256K

Incra Features:

Incremental Assembler

- ☆ Complete macro assembler
- ☆ Supports 8086/88, 80186, 80286, 8087, 80287
- ☆ Also operates in batch mode (faster than MASM 5.0)
- ☆ Compatible with MASM 5.0 (will assemble most MASM 5.0 programs without changes)

Editor

- ☆ Full Screen, fully featured
- ☆ Syntax checking
- ☆ Automatic INCREMENTAL assembly
- ☆ Customizable Options
- ☆ Unique line buffer for moving and re-ordering lines
- ☆ Super fast search and page
- ☆ Instantly generates .exe and .obj files
- ☆ Template program files
- ☆ Lots more!

Debugger

- ☆ Window-oriented – see all data, registers, flags, and executing source lines (with comments) at a glance
- ☆ Fully symbolic (no need to declare publics)
- ☆ Single step, multiple breakpoints, conditional breakpoints, check-trace
- ☆ Highlights changes to registers, flags & data at each step
- ☆ Powerful symbolic data display options
- ☆ Save and restore data display definitions
- ☆ Disassemble with symbolic names
- ☆ Flip to and from your program's display screen
- ☆ Lots more!

Linker

- ☆ Faster than MASM 5.0
- ☆ Link incra files, regular .obj files, and libraries

Macros

- ☆ Full macro capabilities
- ☆ Macros can be instantly expanded in the editor to inspect resulting source
- ☆ Full conditional assembly is supported

Calculator

- ☆ Available at all times
- ☆ Complete set of arithmetic and logical operations
- ☆ All program constant and offset values are available as operands
- ☆ Hex, decimal, octal, binary, ascii results and operands accepted

Options

- ☆ Change environment features such as screen colors, cursor type, tabs, processor type, etc.
- ☆ Save options permanently

Help

- ☆ Pop-up command descriptions available at all times

To order: Call (U.S.A. or Canada)

1-800-387-8722

or send check or money order to:

daystar
COMPUTING

25 Warrender Ave., Suite 909
Islington, Ontario Canada
M9B 5Z4
(dealer inquiries welcome)

Listing 3: An ExTalk application-specific function. This routine uses the Macintosh LineTo routine to draw a line from the current pen position to the position given by the top two arguments of the ExTalk machine's stack.

```

/* ex_lineto - application function 'lineto' */
int ex_lineto()
{
    WindowPtr save;
    int h,v;
    chktype(0,DT_INTEGER);
    chktype(1,DT_INTEGER);
    h = sp[1].v.v_integer;
    v = sp[0].v.v_integer;
    GetPort(&save);
    LineTo(h,v);
    SetPort(save);
    sp += 2;
    sp->v_type = DT_NIL;
}

```

Listing 4: Drawing a square using the routine defined in listing 3.

```

Function square(x,y,size)
Begin
    MoveTo(x,y);
    LineTo(x+size,y);
    LineTo(x+size,y+size);
    LineTo(x,y+size);
    LineTo(x,y);
End

```

Listing 5: This routine in the ExTalk compiler contains the parsing for "+" and "-" operators within an expression.

```

do_expr2()
{
    int tkn;
    do_expr3();
    while ((tkn = token()) == '+'
        || tkn == '-')
        switch (tkn) {
            case '+':
                putcbyte(OP_PUSH);
                do_expr3();
                putcbyte(OP_ADD);
                break;
            case '-':
                putcbyte(OP_PUSH);
                do_expr3();
                putcbyte(OP_SUB);
                break;
        }
    stoken (tkn);
}

```

Listing 6: Defining classes within ExTalk. This code defines a class called Square.

```

Class Square
IVars x,y,size;
CMethod [self new_x: xx y: yy size: ss]
    [[super new] init_x: xx y: yy size: ss]
Method [self init_x: xx y: yy size: ss]
Begin
    x := xx; y := yy;
    size := ss;
    self;
End
Method [self show]
Begin
    MoveTo(x,y);
    LineTo(x+size,y);
    LineTo(x+size,y+size);
    LineTo(x,y+size);
    LineTo(x,y);
    self;
End
Method [self x: xx y: yy]
begin
    x := xx;
    y := yy;
    self;
end;

```

ExTalk repeats this process until it no longer finds a "+" or a "-", and then calls the stoken() function, which saves the current token so that the next call to token() won't lose whatever token do_expr2() didn't match.

Object-Oriented Programming

I designed ExTalk to support object-oriented programming. In addition to being able to define functions, you can also define classes of objects in ExTalk. Listing 6 is an illustration of an ExTalk class definition.

This class definition describes a class called Square with instance variables x, y, and size. Each instance of this class will have values for each of the instance variables. Instances respond to the message show by displaying the square, and to the message x:y: by moving the square to a new location. The Square class itself responds to the message new_x:y:size: by creating a new instance and then initializing its instance variables.

A message expression consists of an open bracket followed by an expression that evaluates to the object that is to receive the message. In the case of unary messages, the receiver is followed by the message selector. The message show is an example of a unary message (a message with no arguments).

In the case of messages that take argu-
continued

Receive a
FREE*
SIVA
386
SYSTEM

with the purchase of \$2995++ of software or \$4995++ of hardware.

Standard 386 Features:

- 32-bit Intel 80386-16 CPU.
- 1MB of 32-bit RAM on board. System expandable to 16MB.
- 8/16/20 MHz Keyboard selectable.
- ST-251-I Seagate 40MB Formatted 28 ms high speed, with ultra high speed Controller 1:1 interleave.
- 1.2MB High Capacity Floppy Drive.
- Super deluxe heavy duty tower case with 6 half-height drive openings.
- High-resolution 12" Non-Glare Amber Display. Tilt and Swivel base, Hercules-compatible Adapter.
- 101 Key Enhanced Keyboard, Pleasant "Tactile/Click" Feel.
- 80287/387 Math-Coprocessors optional.
- Fully compatible with virtually all XT/AT and 386 software.

Upgrades for your FREE 386 System:

- VGA Color Upgrade — add only \$495.
- 20 MHz CPU Upgrade — add only \$195.
- Call for all other options and upgrades.

Choose Your Hardware

A hardware purchase of \$4995 or more is required to receive the SIVA 386 System FREE.

- | | |
|---|--------|
| • QMS PS 800II Postscript Laser Printer | \$5995 |
| • QMS PS 810 Postscript Laser Printer | \$4995 |
| • CDC WREN IV 300MB SCSI Hard drive with Controller | \$2595 |
| • CDC WREN III 155MB SCSI Hard drive with Controller | \$1795 |
| • CDC WREN II 86MB ST506 Hard drive with HD/FD Controller | \$ 895 |
| • Eight Port RS232 Intelligent Card with Xenix Driver | \$ 995 |
| • 32-Bit 8MB Memory Expansion Board | \$2997 |
| • Intel 80387 — 16 Coprocessor | \$ 495 |

Software

- | | |
|---|--------|
| • Complete SCO Xenix System (including Operating System, Developing System and Text Processing System for 80386-based System) | \$1595 |
| • SCO Lyrix System | \$ 595 |
| • SCO Professional | \$ 895 |
| • SCO Integra | \$1295 |
| • SCO Foxbase Plus | \$ 995 |
| • SCO VP/IX (integrated DOS environment — two users) | \$ 495 |
| • Language & Development Tools | CALL |
| • Networking & Communication Packages | CALL |

A software purchase of \$2995 or more is required to receive your FREE SIVA 386 System. Mix and match to meet your needs!

Prices are for Industry Standard 80386-based Computers. For all other systems and items please call:

1-800-252-4212

VNS America Corp.

Suite 270, 910 Boston Post Road
 Marlboro, Massachusetts 01752 U.S.A.
 In Massachusetts 508-460-0016
 FAX: 508-481-2218

*Offer good until December 31, 1988.

Circle 355 on Reader Service Card

SOME ASSEMBLY REQUIRED

1	Exxon	25	Standard Oil (Ohio)	49	Consolidated Foods
2	General Motors	26	AT&T Technologies	50	Lockheed
3	Mobil	27	Boeing	51	Georgia-Pacific
4	Ford Motor	28	Dow Chemical	52	Monsanto
5	IBM	29	Allied	53	W.R. Grace
6	Texaco	30	Eastman Kodak	54	Signal Companies
7	E.I. du Pont	31	Unocal	55	Anheuser-Busch
8	Standard Oil (Ind.)	32	Goodyear	56	Nabisco Brands
9	Standard Oil of Cal.	33	Dart & Kraft	57	Johnson & Johnson
10	General Electric	34	Westinghouse Elec.	58	Coastal
11	Gulf Oil	35	Philip Morris	59	Raytheon
12	Atlantic Richfield	36	Beatrice Foods	60	Honeywell
13	Shell Oil	37	Union Carbide	61	Charter
14	Occidental Petroleum	38	Xerox	62	General Mills
15	U.S. Steel	39	Amerada Hess	63	TRW
16	Phillips Petroleum	40	Union Pacific	64	Caterpillar Tractor
17	Sun	41	General Foods	65	Aluminum Co. of Amer.
18	United Technologies	42	McDonnell Douglas	66	Sperry
19	Tenneco	43	Rockwell Int.	67	Gulf & Western Ind.
20	ITT	44	PepsiCo	68	Continental Group
21	Chrysler	45	Ashland Oil	69	Bethlehem Steel
22	Procter & Gamble	46	General Dynamics	70	Weyerhaeuser
23	R.J. Reynolds Ind.	47	3M	71	Ralston Purina
24	Getty Oil	48	Coca-Cola	72	Colgate-Palmolive

27 million Americans can't read. And guess who pays the price.

While American business is trying to stay competitive with foreign companies, it's paying an added penalty. The penalty of double-digit illiteracy.

Believe it or not, 27 million American adults can't read and write. Another 47 million are literate on only the most minimal level. That adds up to almost one third of our entire population... and probably a disturbing number of *your* employees.

What does illiteracy cost you? Get out your calculator. Illiterate adults make up 50%-75% of our unemployed. Every year they cost us an estimated \$237 billion in lost earnings. They swell our welfare costs by \$6 billion annually and diminish our tax revenues by \$8 billion.

Illiteracy costs you through your community, too. It robs the place where you work and live of its resources. It undermines the potential of the people who make your products and the people who buy them. No dollar figure can be assigned to this. But over the years, this may be the costliest loss of all.

What can your company do about this? It can join in local efforts to fight illiteracy. It can volunteer company dollars and facilities for better school and tutorial programs. It can invest in a more literate community.

The first step is to call the Coalition for Literacy at **1-800-228-8813** or fill out the coupon below. Do it today. You may find it's the greatest cost-saving measure your company has ever taken.

**A literate
America
is a good
investment.**



Coalition for Literacy

- I want my company to join the fight against illiteracy.
Please send brochure with additional information
- We want to discuss funding the Coalition for Literacy
Please have a representative contact me

Name _____

Title _____

Company _____

Address _____

City _____ State _____ Zip _____

Phone _____

Please return to: Coalition for Literacy
Business Division
PO Box 81826
Lincoln, NE 68501 1826

ments, each argument is preceded by a keyword. The string resulting from combining all the keywords is the selector. For instance, the message [mysquare x: 10 y: 20] will move mysquare to (10,20). The selector for this message is the string x:y:, and the arguments are 10 and 20.

Here is an example of creating a new instance of the class Square:

```
mysquare := [Square new_x: 100 y:
             200 size: 20]
```

Once you have created an instance of the Square class and stored it as the value of the symbol mysquare, you can display it using this expression:

```
[mysquare show]
```

You can move it to a new location using this expression:

```
[mysquare x: 100 y: 200]
```

You can use objects to model parts of the application. For instance, a word processing program might have classes of objects to represent chapters, paragraphs, and footnotes. A communications program could use objects to represent conferences and messages during communications with an on-line service like BIX. See the August 1986 BYTE for a complete description of object-oriented programming.

Portable Simplicity

ExTalk is a simple language that can be embedded in an application to provide user programmability. It is easily understood by people who are familiar with C, Pascal, or modern versions of BASIC, and its implementation is portable across different machines and operating systems. It should be useful to developers who want to add an embedded language to their applications.

Next Month

Rick Grehan returns with a series on large database management using keyed files. ■

Editor's note: *ExTalk* is available in a variety of formats. See page 3 for details.

David Betz is the author of the popular XLisp programming language. He can be reached on BIX as "dbetz."

Your questions and comments are welcome. Write to: Editor, BYTE, One Phoenix Mill Lane, Peterborough, NH 03458.

Brand Names • Great Prices • Quick Delivery



**EXPO SUPER TURBO
30 MB SYSTEM**

\$885

10 MHz

- 512K
- 360K FLOPPY DR.
- 20 MB SEAGATE HARD DRIVE

- MONO/GRAPHICS/PARALLEL
- HI-RES AMBER MONITOR
- AT KEYBOARD



**EXPO 286/10
\$1395**

12 MHz
\$1410

- 80286 10MHz SPEED
- 640K RAM (1MB CALL)
- 1.2 MB FLOPPY
- 40 MB HARD DRIVE
- WD CONTROLLER
- MONO MONITOR SYSTEM
- KEYBOARD



AT&T 6300 WGS

\$1495

40 MB System \$1697

- 360K Floppy Drive
- 640K Ram
- 30 MB Hard Drive

- Monochrome Display
- High Res. Graphics
- Parallel, Serial & Clock



NX-1000
Multiple Font
Friction/Tractor
Paper Parking
144 CPS/36 CPS

\$179

PRINTERS	CPS	COL	\$
NX-15	120/30	136	\$329
ND-10	180/45	80	\$299
ND-15	180/45	136	\$389
NR-10	240/60	80	\$329
Cable			\$ 10



SERIAL MOUSE

\$75

GENIUS MOUSE SERIAL

\$59



- 20MB w/Controller **\$265**
- 30MB w/Controller **\$285**
- 30MB ST-4038 **\$485**
- 40MB ST-251 **\$395**
- 40MB ST-251-1 **\$485**
- 80 MB ST-4096 **CALL**
- 130 OR 230 MB (13MS) **CALL**
- PS/2 HARD DRIVE UP GRADE **CALL**

INCLUDES: Bootable from Hard Disk, Controller, Cables, Hardware, Easy Instructions, Software, 1 Year Warranty

AT DRIVES

- 80 Meg ST4096\$739
- 40 Meg ST251-1\$449

EVEREX MODEMS \$79

- 1200 BAUD\$79
- 2400 BAUD INT\$169



**MITSUBISHI DIAMOND SCAN
14" MULTISYNC MONITOR W/GENOA
EGA 800x600
RES**

SPECIAL COMBO PAK

- Genoa Super EGA Card
- 100% Multi Sync Compatible
- CGA Double Scan
- 800x600 • Drivers for Auto CAD, Windows, GEM, Ventura, Pagemaker & more. • 100% IBM EGA Compatible • 132 Column Drivers for Lotus 1-2-3 & Symphony • 80x60 Desktop Publishing



Genoa EGA Adapter **\$195**
(if bought separate)



- 1410C 640X350\$409
- 1430C 640X350469
- 1371 Diamond Scan 800x560499
- 1409C 640x200299



- 1453 EGA 640x350\$359
- Mono Tilt 'N' Swivel\$89

EGA Display Adapter
\$469



**EBS PORTABLE
10MHz SPEED**

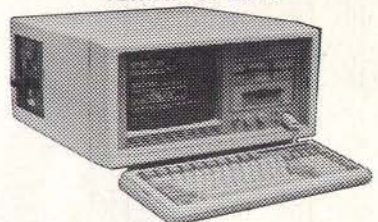

\$1397 COMPLETE
WITH 20 MB SEAGATE SYSTEM

- 8088-1P 4.77/10 MHz SPEED
- 360 K FLOPPY DRIVE
- 20 MB SEAGATE HARD DRIVE
- MONO/GRAPHICS/PARALLEL
- HI-RES AMBER MONITOR
- SERIAL/PAR/CLOCK/GAME

40 MB SYSTEM COMPLETE **\$1550**
CALL FOR 286 & 386 MODEL

**EBS PORTABLE IV
286/12 MHz**

\$1495



- 80286/12MHz CPU
- 1.2 MEG. FLOPPY DRIVE
- 640K RAM (1MB RAM ADD \$195)
- HI-RES LCD DISPLAY
- 640X200 PIXEL (80X25 LINES)
- 5 EXPANSION SLOT
- EXTERNAL RGB/COLOR PORT
- DIMENSIONS
8 1/4(H) x 9 1/2(W) x 15 1/4(D)

20 MEG SEAGATE SYSTEM **\$1695**

40 MEG SEAGATE SYSTEM **\$1895**

FUJITSU

- 360K 1/2HT 5.25"\$79
- 1.2M 1/2HT 5.25"\$95
- 720K 1/2HT 5.25"\$99

VIDEO ADAPTERS

- Paradise EGA.....\$115
- Monographic w/Port.....\$59
- Colorgraphic w/Port.....\$69

**WESTERN DIGITAL
ENHANCED PERIPHERALS**

- 16 Bit Fixed/Floppy
- Controlled WAHZ\$115
- 16 Bit Fixed Disk Controller WAH...\$109
- Cable Set\$9
- EGA 640x350\$115
- RLL XT Controller\$89
- XT Controller.....\$79

CALL FREE

ORDER LINES ONLY



1-800-622-EXPO

INQUIRE 713-784-0990

SERVICE 713-784-7817

COMPUTER EXPO

TEXAS # 1 IBM™ COMPATIBLE COMPUTER CENTER

Returned items must be as new, without modifications or damages, with all manuals and warranty card, and in original packaging. Returned items must include a return authorization number on the shipping label. NO CREDIT issued after 30 days from the date of original shipment.

THIS AD WAS TYPESET ON A LOW COST LASER PRINTER USING

A *FREEDOM*
OF
*PRESS*TM
B **C** **D** **E** **F** **G** **H** **I** **J** **K** **L** **M** **N** **O** **P** **Q** **R** **S** **T** **U** **V** **W** **X** **Y** **Z**

Dyna Computer Gives You **FREEDOM OF PRESS**TM

Set Your Printer's PostScript® Potential Free.

Without going on a spending spree.

Now you can do PostScript® on most 24 wire dot matrix, laser printer and ink jet printers and avoid the outlandish prices of postscript printers.

YOU CAN DO ALL OF THIS FOR ONLY \$495

Freedom of Press works with any desktop publishing software that generates its output in the PostScript® language. That includes such popular programs as PageMaker® and Ventura® as well as virtually all other text-and-graphic software now available.

You'll find Freedom of Press just as versatile when it comes to typefaces: there are 35 high quality outlines equivalent to those found on the LaserWriter Plus®. And Freedom of Press typefaces can be scaled to any type size and rotated to any angle. Freedom of Press supports the vast majority of laser printers and 24 wire dot matrix printers as well as the ink jet printers. Now that's versatility.

Freedom of Press is a highly advanced program that incorporates many advantages found only in the most sophisticated imaging systems. For example, it uses the highest quality font scaling available, not just simple reduction/enlargement of a single image. And no matter what your printer, you can be sure Freedom of Press will let you obtain the highest resolution it is capable of producing.

Its Low Cost. A new PostScript-ready laser printer can run you as much as \$7000. But Freedom of Press lists for just \$495. It's easy to install and to use, thanks to features like automatic printing and bar-graph interpretation and imaging status. CALL FOR YOUR LOCAL DEALER TO RECEIVE FURTHER INFORMATION

Dyna Computer is proud to be distributing high quality software created by a proven company. Freedom of Press is made by custom applications inc. (CAI), the same company that supplies many leading printer manufacturers with their PostScript language interpreters. CAI's experience in such demanding areas as phototypesetting translates into proven, professional software for you. In addition Dyna Computer brings you seven years of computer manufacturing innovations and distribution experience to your automation needs. Our new 30Mhz 386 cache tower computer systems and AT upgrade board offers you the "one step ahead" performance you would expect from one of the first compatible manufacturers in the United States. Whether its Freedom of Press™ or the Fastest 386 systems on the market, Dyna Computer is the right place to go. One other thing. Dyna's prices ..are right and so is our service. If you can't afford to buy a 386, there is a good chance we can arrange a lease for you. GIVE US A CALL AND LETS TALK ABOUT IT.

FREEDOM OF THE PRESS™. BROUGHT TO YOU BY DYNA COMPUTER, A COMPATIBLE MANUFACTURER THATS ONE STEP AHEAD. CALL ABOUT FREEDOM OF PRESS™ OR OUR NEW 30MHZ CACHE 386. IT GETS AN SI RATING O F 36.3 AND ITS GREAT FOR DESK TOP PUBLISHING APPLICATIONS. PHONE 408-943-0100.

Freedom of Press is a trademark of Custom Applications, Inc. The following are trade marks of their owners: PostScript-Adobe Systems, Inc.; Page Maker-Aldus Corp.; Ventura-Ventura Software, Inc.; LaserWriter Plus-Apple Computer, Inc.

DYNA
COMPUTER

3081 NORTH FIRST ST., SAN JOSE, CA 95134

(408) 943-0100 FAX (408) 943-0642

ADDING DIMENSION

Here's a technique that provides the fastest possible access to an array element in C

Many of today's popular programming languages support the multidimensional arrays used in graphics, modeling, and simulation or even for locating a specific position on a screen. Most implementations of BASIC do; Turbo Pascal does; FORTRAN does; but C does not. Is there any way around this omission? You bet there is. You can implement `DIMENSION A (N,M)` and `X=A(I,J)` in C, and not through a pseudo-dimensional substitute either. I know, because I've done it.

If you have a compiler that supports structure return, you can also write statements such as

```
X = matrix_operator(A,B);
```

where A, B, and X are matrix structures and operator can be multiply, add, inverse, and so forth. Most important, the function `matrix_operator()` can dynamically dimension X, and you can access elements by applying the simple bracketed-integer access format.

Problem Evaluation

To analyze the problem, consider the basic two-dimensional array of floating-point numbers or matrix. If you declare it as

```
double array[n][m];
```

then there will be a minimum of $n \times m$ double units of storage allocated at compile time in the current storage class. With this method, you must set n and m

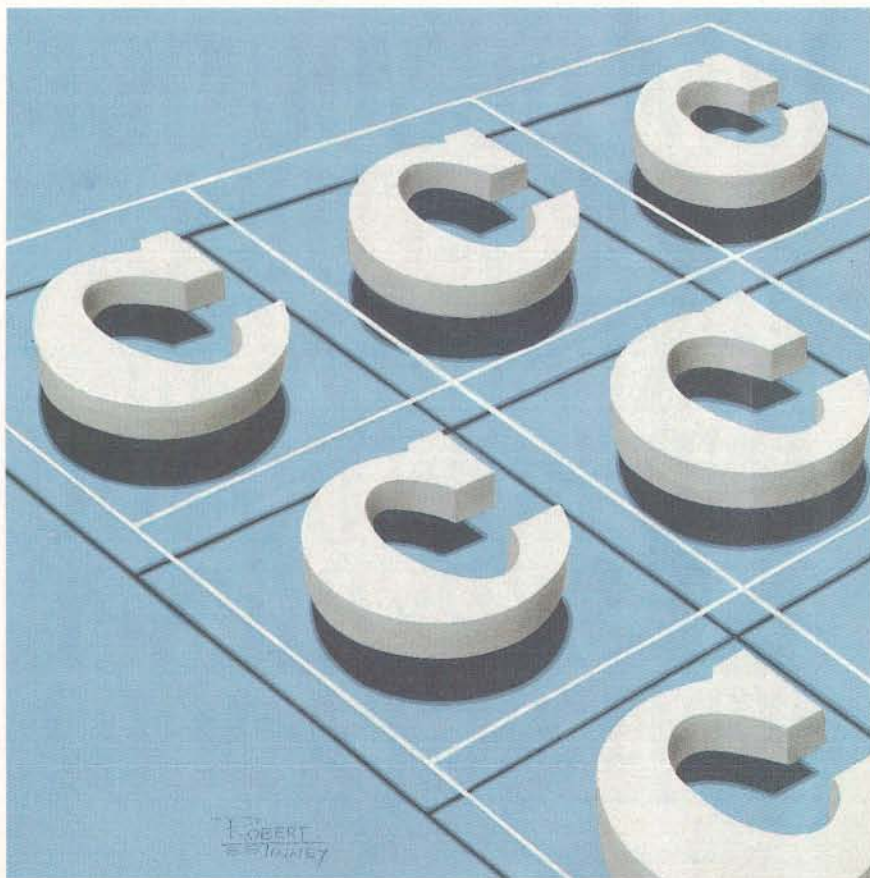

constant before compiling, a statement that would be illegal in C if n and m were variable. As a consequence, you must allocate memory whose size will depend on the maximum size of array expected. Moreover, if this array is declared as local storage class, then it may consume valuable stack space.

A Pseudomultidimensional Dynamic Array

There is a simple way you can create a pseudomultidimensional dynamic array by using the `malloc()` function with a pointer to the desired storage unit. Consider the array whose label is A. The fol-

lowing method transforms A into a one-dimensional array with multidimensions `dim_1, dim_2, ...`

```
double *A;
A = (double *)
    malloc(sizeof(double)
           * dim_1 * dim_2 * ...)
```

According to the rules of C, you can only access elements in this type of array by one index: `x = A[q];`

This method, therefore, has a major drawback; to access individual elements, you must present array size variables

continued

dim_1, dim_2, and so on at every indexing operation, multiply them by the corresponding index, then add them together to reduce to the required offset q that corresponds to the linear array A . For example, if you wanted to extract $A(i,j, \dots, k)$, you would write

```
x = A[ (i * dim_1) + (j * dim_2)
      + ... + k ];
```

Although this method is feasible, it can be-

come awkward even when you try a simple operation such as matrix multiplication.

The One-Dimensional Array

To evolve a general method for elegantly handling multidimensional dynamic arrays, you first construct a memory-allocation function so the allocated memory can be accessed by integer indices. You do this with the `calloc()` function.

If an array has only one dimension of n , you can use this simple solution:

```
double *A;
A = (double *)
    calloc(n, sizeof(double));
```

As in the previous pseudomultidimensional case, you can access the i th element by $x = A[i]$; . Once interaction with A is no longer required, you can free the memory with

```
free((char *) A);
```

The Two-Dimensional Array

In order to create a two-dimensional array of size $n \times m$, you must declare a pointer to an array of pointers to the desired storage units by writing

```
double **A;
```

and you must give the pointer variable A memory space for n pointers of size *pointer to double*:

```
A = (double **)
    calloc(n, sizeof(double *));
```

You can access each of the n pointers to *double* by an index, as in the one-dimensional example. The key here is that you must give each of these n pointers memory space for its corresponding m storage units, effectively creating an n -quantity of m -size one-dimensional array containing the desired storage units:

```
for (j = 0; j <= n - 1; ++j)
{
    A[j] = (double *)
        calloc(m, sizeof(double));
}
```

Combine these three sections into a function, and you're finished. Since accessing is done via indirection, the order in which you establish pointers is important. You must give allocation to the highest-level pointer first so the next-level pointer can know of its predecessor's existence. Again, according to the rules of C, you can express the "pointer to pointer to double" variable A as $A[][]$, thus reaching down to the smallest unit—in this particular case, a double. Thus, you can obtain the (i, j) th element by writing $x = A[i][j]$; of the dynamically allocated array A of size n, m . This statement is the corresponding free function to complement the two-dimensional allocation function.

To free the allocated memory, you use a freeing order that is the reverse of the allocation order. Thus, all the memory used by A would be freed accordingly:

continued

HOW DO YOU GET A JOB WITHOUT EXPERIENCE? AND HOW DO YOU GET EXPERIENCE WITHOUT A JOB?

Most young people have one answer to this problem. They avoid it until they're out of college. But they could be getting solid work experience while they're still in college. With your company's help. And ours.

We're Co-op Education. A nationwide program that helps college students get real jobs for real pay, while they're getting an education.

But we can't do it without you.

Those real jobs have to come from real companies. Like yours.

For more information on how you can participate in this valuable program, write Co-op Education, Box 775E, Boston, MA 02115.

Not only will you be giving students a chance to earn money and pick up the most valuable kind of knowledge, you'll be giving yourselves a chance to pick up the most valuable kind of employee.

Co-op Education.

You earn a future when you earn a degree.



A Public Service of This Publication ©1987 National Commission for Cooperative Education

Buy with

Confidence

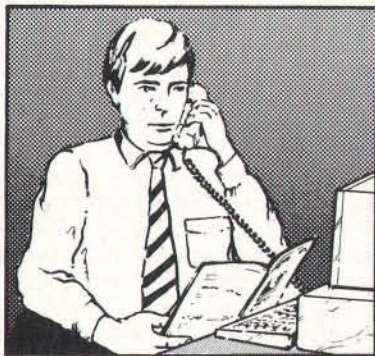

In an effort to make your telephone purchasing a more successful and pleasurable activity, The Microcomputer Marketing Council of the Direct Marketing Association, Inc. offers this advice, "A knowledgeable buyer will be a successful buyer." These are specific facts you should know about the prospective seller before placing an order:

Ask These Important Questions

- How long has the company been in business?
- Does the company offer technical assistance?
- Is there a service facility?
- Are manufacturer's warranties handled through the company?
- Does the seller have formal return and refund policies?
- Is there an additional charge for use of credit cards?
- Are credit card charges held until time of shipment?
- What are shipping costs for items ordered?

Reputable computer dealers will answer all these questions to your satisfaction. Don't settle for less when buying your computer hardware, software, peripherals and supplies.

Purchasing Guidelines

- State as completely and accurately as you can what merchandise you want including brand name, model number, catalog number.
- Establish that the item is in stock and confirm shipping date.
- Confirm that the price is as advertised.
- Obtain an order number and identification of the sales representative.
- Make a record of your order, noting exact price including shipping, date of order, promised shipping date and order number.

If you ever have a problem, remember to deal first with the seller. If you cannot resolve the problem, write to MAIL ORDER ACTION LINE, c/o DMA, 6 E. 43rd St., New York, NY 10017.

This message is brought to you by:

the MICROCOMPUTER
MARKETING COUNCIL
of the Direct Marketing
Association, Inc.
6 E. 43rd St.,
New York, NY 10017

MMC
MICROCOMPUTER
MARKETING COUNCIL
of the Direct Marketing Association, Inc.

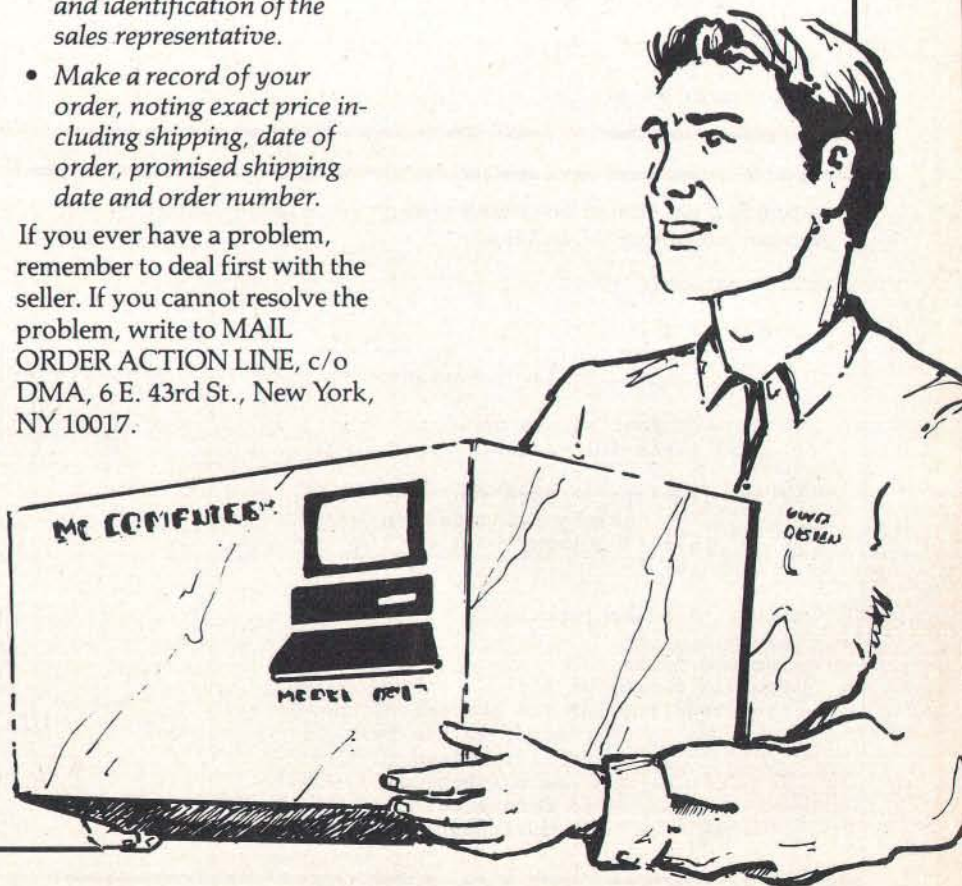

```
for (j = n - 1; j >= 0; j--)
{
    free((char *) A[j]);
}
free((char *) A);
```

Note that the rightmost dimension of *m* is not required. This is because the last call to `calloc()` in the allocation function manages unit storage internally. `A[][]` is a scalar and not a pointer, whereas `A`

and `A[]` were established as pointers and therefore can be the only ones freed.

Listing 1: This listing illustrates the dimensioning function for a three-dimensional array `A(m,n,p)`.

```
double *** A;

A = (double ***) calloc(n, sizeof
                        (double**));
for (j = 0; j <= n - 1; j++)
{
    A[j] = (double **) calloc(m,
                             sizeof(double *));
    for (i = 0; i <= m - 1; i++)
    {
        A[j][i] = (double *) calloc(p,
                                     sizeof(double));
    }
}
```

Listing 2: This is the corresponding three-dimensional freeing function.

```
for (j = n - 1; j >= 0; j--)
{
    for (i = m - 1; i >= 0; i--)
    {
        free((char *) A[j][i]);
    }
    free((char *) A[j]);
}
free((char *) A);
```

Listing 3: If you want to have access to an array created by another function, you can use this technique.

```
main_function()
{
    double ** X;
    X = other_function(); /* [X]
                          is dimensioned. */
    .
    . /* Your access to what
       . was [A] via pointer [X]. */
    .
    matrix_free(X); /* Here you free
                    memory allocated by */
} /* other_function() to clean the
   heap. */

double ** other_function()
{
    double ** A;
    matrix_dimension(A);
    return(A); /* The address of the
               array in the heap */
} /* is returned to the
   main_function() */
/* before pointer A
   disappears. */
```

The General Case

For the three-dimensional array `A(m,n,p)`, you would use the dimensioning function in listing 1. You should see a pattern emerging that can be carried to any number of dimensions.

You can access the (*i, j, k*) element by `x = A[i][j][k]`. The corresponding three-dimensional freeing function is shown in listing 2. As before, the rightmost dimension is not required.

With this method, you should watch for a number of things regarding the use of the `calloc()` and `free()` functions. Be aware that `calloc()` allocates memory in the "heap." This means that if you create a dynamic array `A` within your function, even if the pointer variable `A` were declared local, that array should be freed upon exit from your function.

The reason for this operation is that heap management generally is handled by the operating system, and memory allocated there is not recovered automatically on exit from the allocating function as local stack variables would be. Moreover, the scope of the pointer variable `A` is only function-wide, and when the function is exited, the variable's address information is gone.

The remaining problem is that, to the operating system, the allocated portion of memory still seems occupied. Therefore, subsequent calls to your function will pile up memory in the heap until there is no more memory available. Your function, however, will continue to operate properly, but only up to that point.

This restriction would be imposed in a situation where you want to have access to an array created by another function. To overcome it, you apply a technique similar to the pseudocode in listing 3.

Now you have the complete solution. The upshot of this method is that only one pointer is passed as argument, not the entire array. There may be instances where you require a copy of the original array, and you can easily program according to C rules.

A Note for 8086 Programmers

A key advantage of this method for 8086-type segmented memory is that when you compile your program for the large memory model, each indexed pointer will be assigned its own data segment, because it is treated as a far variable. That is, the declaration

```
double **A;
```

continued

INTRODUCING THE FIRST LOADER WITH SMARTS!

PROLOADER II

A 3rd GENERATION TECHNOLOGY



A complete package
from \$1,595.00

PROLOADER II is CONVERTIBLE
3.5" and 5.25", the same loader does both

Converts from one disk size
to the other in seconds

PROLOADER II is FLEXIBLE

*All disk drive types and
multiple disk formats supported

*Interfaces for IBM™, Apple™ and Macintosh™

PROLOADER II is RELIABLE

*Revolutionary disk loading method
creates a new standard in reliability

VAULT'S PROLOADER II

*Born of a company that has duplicated
over 4,000,000 disks.*

** Designed from experience.*



Contact VAULT CORPORATION at
2192 Anchor Court, Unit "C", Newbury Park, CA 91320
or call TOLLFREE
800-445-0193 (Nationwide) or 800-821-8638 (California)

PROLOK™

ROMLOK™

HDPROLOK™

FILELOK™

TECHLINE™

UNILOK™

PROLOADER II IS A TRADEMARK OF VAULT CORPORATION. IBM IS A TRADEMARK OF INTERNATIONAL BUSINESS MACHINES CORP. APPLE and MACINTOSH ARE TRADEMARKS OF APPLE COMPUTER
COPYRIGHT ©1988 VAULT CORPORATION

Circle 347 on Reader Service Card

NOVEMBER 1988 • BYTE 423



RS-232/422

Make your computer into a serial data analyser by plugging in our hardware/software.

→ COMSCOPE →

No internal changes required, just plug into two serial ports on your IBM XT/AT or compatible and run our software (we have extra serial ports available). Provides data code conversion & capturing, saving to disk files. For passive data collection or generating messages and capturing reply. At this price there is no excuse not to have one! C/ w 120V adaptor.....\$399

AI INDUSTRIAL AUTOMATION INC.
P.O. Box 8019 Blaine, WA 98230 FAX: 604-946-0343
Phone: 604-946-4523 or 604-270-9614

Circle 161 on Reader Service Card

ON TARGET ASSOCIATES

Products and Services
for Design and Manufacturing Engineers.

- Micro Channel Design Consulting
- Prototype Cards
- Newsletter
- ASIC's
- Extender Cards
- Adapter Bracket Sets
- Burn-in Mother Boards

PS/2

We will move your PC/XT/AT products to the Micro Channel, or create your new design.

CALL: (408) 980-7118
for our Free catalog

ON TARGET TARGET
...the PS/2 leaders.

PS/2 and Micro Channel are trademarks of IBM Corp.

Circle 241 on Reader Service Card

UNIVERSAL LOGIC PROGRAMMER

- PROGRAMS, READS, DUPLICATES, TESTS AND SECURES HUNDREDS OF 20- AND 24-PIN DEVICES
- 23 UNIVERSAL PIN DRIVERS WITH INDEPENDENT DAC, ADC & SLEW FUNCTIONS PROGRAM ALMOST ANY LOGIC DEVICE
- MENU DRIVEN OPERATION IS EASY TO LEARN AND QUICK TO OPERATE
- CONNECTS TO ANY IBM COMPATIBLE COMPUTER VIA PARALLEL PRINTER PORT
- EDITS FUSE DATA & TEST VECTORS WITH FULL SCREEN EDITOR
- TESTS WITH VECTORS & SECURES AFTER PROGRAMMING
- SUPPORTS ALL POPULAR PLD DEVELOPMENT SOFTWARE
- GOLD TEXT TOOL ZIF IC SOCKET
- ONLINE HELP FUNCTION
- MONEY BACK GUARANTEE
- SELF CALIBRATING
- TOLL-FREE TECH SUPPORT
- JEDEC FILE IN/OUTPUT
- UPDATABLE VIA FLOPPY
- ONE YEAR WARRANTY
- EPROM PROGRAMMERS ALSO
- SAME DAY SHIPMENT
- JUST \$798

CALL FOR FREE DEMO DISK 800/225-2102

BP MICROSYSTEMS
10681 HADDINGTON #190 HOUSTON, TX 77043
713/461-9430 TLX: 1561477 FAX: 713/461-7413

Circle 54 on Reader Service Card

EPROM PROGRAMMER

\$ 3 4 9



THE EP-1'S A GREAT VALUE AND HERE'S WHY:

- READS, PROGRAMS, COPIES OVER 350 EPROM AND EEPROMS FROM 30 MFG'S INCLUDING 2716-27513, 2804-28256, 27011
- READS/WITES INTEL, MOTOROLA, STRAIGHT HEX & BINARY
- OPTIONAL HEADS PROGRAM INTEL 874X, 8751, 87C51, 8755
- MENU-DRIVEN CHIP SELECTION BY MFG & P/N; NO MODULES
- FAST, SLOW, QUICK PULSE PROGRAMMING ALGORITHMS
- SPLITS FILES BY BASE ADDRESS AND ODD/EVEN (16 & 32 BIT)
- ALL INTELLIGENCE IN UNIT, Z80 MICROPROCESSOR BASED
- 5, 12.5, 21.25 V PROGRAMMING FOR CMOS & -A SUFFIX PARTS
- FREE PC-DOS SOFTWARE
- RS232 TO ANY COMPUTER
- GOLD TEXT TOOL ZIF SOCKET
- 8 BAUD RATES TO 38,400
- MONEY BACK GUARANTEE
- ONE YEAR WARRANTY
- 2 FREE FIRMWARE UPDATES
- SAME DAY SHIPMENT
- CHECKSUMS SUPPORTED
- UV ERASERS FROM \$34.95

CALL TODAY FOR MORE INFORMATION
800/225-2102

BP MICROSYSTEMS
10681 HADDINGTON #190, HOUSTON, TX 77043
713/461-9430 TLX: 1561477 FAX: 713/461-7413

Circle 54 on Reader Service Card

16-BIT RESOLUTION ANALOG-TO-DIGITAL CONVERTER

12,000 SAMPLES/SEC for IBM PC, XT & AT

SINGLE PIECE PRICE \$475

We manufacture a broad line of data acquisition and control hardware and software for Apple and IBM computers.

Call for quotes on custom hardware or complete systems.

LAWSON LABS, INC.
5700 RAIBE ROAD
COLUMBIA FALLS, MT 59912
800-321-5355 or 406-387-5355



Circle 187 on Reader Service Card

8051 FAMILY EMULATORS



For info call:

Austria	02 22 38 76 38-0
Australia	02 654 1873
Denmark	02 65 81 11
Finland	See Sweden
France	01 69 412 801
Great Britain	01 464 2586
Israel	03 499034
Korea	02 784 7841
New Zealand	04 886 375
Norway	See Sweden
Portugal	01 83 56 70
Spain	03 217 2340
Switzerland	01 740 41 05
West Germany	08 131 16 87
Sweden	040 92 24 25
U.S.A.	408 866 1820

NOHAU CORPORATION
51 E. Campbell Ave., #107E
Campbell, CA 95008
(408) 866-1820

Circle 238 on Reader Service Card

becomes equivalent to
double far * far * A;

or "A is a far pointer to an array of far pointers to double."

You can calculate the total number of segments from the following formula:

$$\left[\sum_{i=1}^{k-1} A_i \right] + k$$

This formula shows a k -dimensional array where A_i are the dimensions of the array name with A_1 the leftmost and A_k the rightmost:

array_name[A₁][A₂]...[A_k]

Therefore, each indexed pointer can handle 64K bytes of your smallest unit. For the double case here, you can comfortably use all the available memory without resorting to special keywords for one matrix, so long as it is nearly square.

Fastest Possible Access

With this technique, you can create and use multidimensional arrays as easily as in other popular languages. Moreover, when you use C, your program accesses the individual storage units by indirection, as opposed to leaving open a possibility that the final pointer may be resolved by index multiplication. Thus, there is no doubt that you have the fastest possible access to a storage unit.

To get a better idea of how the technique is implemented, you can study the sample program. It uses the following matrix structure:

```
struct mat
{ double **a;
  /* "a" short for "array" */
  int rows;
  int cols; };
```

This structure holds a pointer and two integers that define the size of the matrix. Dynamic C contains an input, output, and do-something functions. ■

Editor's note: *Dynamic C* is available in a variety of formats. See page 3 for further details.

Christopher J. Batory is president of Micropath, a Montreal, Canada, firm specializing in radio-telecommunications software and services. He can be reached on BIX c/o "editors."

TRY THE NEW GENERATION FOR \$30

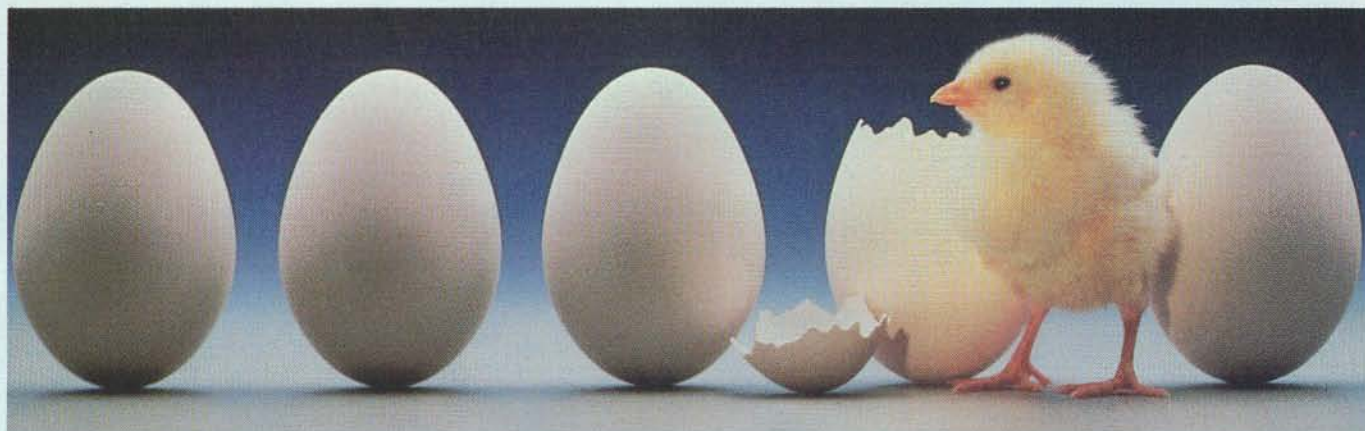

KNOWLEDGEPRO

KnowledgePro uses Topics to store "chunks of knowledge." Topics can contain data, **hypertext**, procedures, calculations, rules, lists and pictures. Using a dozen simple commands, non-programmers can use topics to explain complex procedures, rules or recommendations. Using the other 100 plus commands, professional programmers can create sophisticated expert system tools and applications quickly and easily.

HYPertext

Hypertext can be a powerful tool for organizing text, graphics and data, but without an underlying structure the user becomes lost in a maze of information. KnowledgePro adds structure, control and intelligence to create an exciting new teaching medium.

Once you've used **KnowledgePro** you'll never go back to your shell!

Q. Who's using it?

A. Engineers, Educators, Lawyers, Scientists, Managers, Authors, Bankers, Software Developers, Expert System Developers, Computer VARs and VADs, Trainers, Consultants, Experts in Agriculture, Manufacturing, Insurance, Petroleum, Government and many many more.

Q. What are they doing with it?

A. Intelligent tutorials, smart manuals, procedure guides, rule books, computer aided instruction, sales and promotion, data analysis, non-linear documents, text analysis, diagnostics, software front-ends, expert systems, training and education, hypertext authoring, case studies, insurance claim determination, investment analysis, intelligent forms - there seems to be no limit to the diversity of applications.

Q. What can I do with the demo system?

A. The KnowledgePro demonstration system comes with a 100 page manual and lots of examples to get you started. You can create and save small working knowledge bases. The only commands that you can't use are those for handling external files or chaining knowledge bases. We even credit your \$30 toward the cost of the full system.

Q. How much is the full development system?

A. KnowledgePro costs \$495 and there are no run-time charges, so you don't have to pay more when you distribute your applications. The Database Toolkit (for access to dBASE and Lotus 123 files) costs \$49 and the Graphics Toolkit (for access to PC Paintbrush pictures) costs \$89. Our KnowledgeMaker induction system (for creating rules from data) costs \$99. KnowledgePro runs on IBM PC, AT and PS/2 compatible machines with 640K memory.

TO ORDER Call 518-766-3000 (Amex, Visa, M/C accepted) or send \$30 + \$5 shipping & handling for the demo (\$38 total foreign) or \$495 + \$8 shipping & handling for the full system (\$553 total foreign) to Knowledge Garden, Inc., 473A Malden Bridge Road, Nassau, NY 12123. In NY State please add 7% sales tax.

KnowledgePro[®]

By Bev & Bill Thompson
The first Knowledge Processor.

published
by



In
association
with



KnowledgePro is a registered trademark of Knowledge Garden, Inc., Lotus 123 is a registered trademark of Lotus Development Corp., dBASE is a trademark of Ashton Tate. IBM is a registered trademark of International Business Machines Inc., KnowledgeMaker is a trademark of Knowledge Garden Inc. Photo Tcherevkoff ©

WAREHOUSE SALE

Order These Back Issues of *BYTE* and *Popular Computing* Before They're Gone Forever!

BYTE

Limited Quantities — Order Now!

	1979	1980	1981	1982	1983	1984	1985
January							
February							
March							
April							
May							
June							
July							
August							
September							
October							
November							
December							
Inside the IBM PCs							

\$4.00 U.S. includes shipping and handling
\$5.00 foreign includes shipping and handling

Available Issues

Popular Computing

Limited Quantities — Order Now!

	1982	1983	1984	1985
January				
February				
March				
April				
May				
June				
July				
August				
September				
October				
November				
December				
Special Guide to Computers				

\$3.00 U.S. includes shipping and handling
\$4.00 foreign includes shipping and handling

Special Bound Copies of BYTE

Volume I, Part 2— May 1976 through December 1976

Volume II, Part 1— January 1977 through June 1977

Volume III, Part 1— January 1978 through June 1978

Volume III, Part 2— July 1978 through December 1978

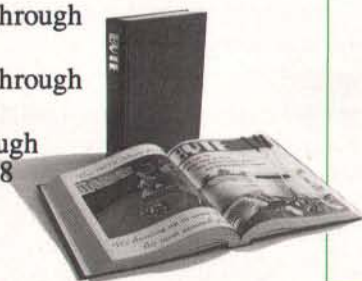

\$9.95 U.S. includes shipping and handling
\$11.95 foreign includes shipping and handling

Check enclosed. Payments from foreign countries must be made in U.S. funds payable at a U.S. bank.

Name _____

Address _____

City _____ State _____ Zip _____

Postcode _____ City _____

Country _____

Please indicate which issues you would like by checking (✓) the boxes.

Send requests with payments to:

BYTE Back Issues
One Phoenix Mill Lane
Peterborough, NH 03458
(603) 924-9281

Charge: VISA MasterCard

Card # _____

Exp. Date _____

Signature _____

BYTE

THE BUYER'S MART

A Directory of Products and Services

THE BUYER'S MART is a monthly advertising section which enables readers to easily locate suppliers by product category. As a unique feature, each BUYER'S MART ad includes a Reader Service number to assist interested readers in requesting information from participating advertisers.

RATES: 1x—\$475 3x—\$450 6x—\$425 12x—\$375
Prepayment must accompany each insertion. VISA/MC Accepted.

AD FORMAT: Each ad will be designed and typeset by BYTE. Advertisers must

furnish typewritten copy. Ads can include headline (23 characters maximum), descriptive text (250 characters is recommended, but up to 350 characters can be accommodated), plus company name, address and telephone number. Do not send logos or camera-ready artwork.

DEADLINE: Ad copy is due approximately 2 months prior to issue date. For example: November issue closes on September 9. Send your copy and payment to THE BUYER'S MART, BYTE Magazine, 1 Phoenix Mill Lane, Peterborough, NH 03458. For more information call Mark Stone at BYTE 603-924-3754.

ACCESSORIES

FREE CATALOG

Thousands of parts and new surplus electronic parts at super low prices. **FAST ORDER PROCESSING AND SHIPPING** (95% of all orders shipped within 48 hours).

CALL OR WRITE FOR A FREE CATALOG...

ALL ELECTRONICS CORPORATION
P.O. Box 567, Van Nuys, CA 91408-0567

1-800-826-5432

Inquiry 576.

ACCESSORIES

SMART PRINTER STAND

UNDERSTAND

is an attractive printer stand with switchable data conversion, surge suppression & power switch. Saves space & avoids clutter!

UNDERSTAND-PP:
\$295 (2 parallel in, 1 parallel out)

UNDERSTAND-PS:
\$395 (1 parallel & 1 serial in, 1 parallel out)

MAS Inc.

15941 S. Harlem Ave., Suite 333, Tinley Park, IL 60477
(815) 469-4501

Inquiry 581.

ARTIFICIAL INTELLIGENCE

muLISP™ 87 for MS-DOS

Fast, compact, efficient LISP programming environment. muLISP programs run 2 to 3 times faster & take 1/2 to 1/3 the space of other LISPs. 450 Common LISP functions, multi-window editing & debugging, flavors, graphics primitives, lessons & help, demo programs, comprehensive manual.

Soft Warehouse, Inc.

3615 Harding Ave., Suite 505, Honolulu, HI 96816
(808) 734-5801

Inquiry 585.

ARTIFICIAL INTELLIGENCE

EXPERT SYSTEM DEVELOPMENT

Get **AGNESS** to develop network based expert systems using multiple inference methods, the Merit scheme for efficient data collection, and unique explanation facilities. Use the **AGNESS C. talk Toolkit** to embed an expert system into your application under an object oriented environment.

Applied Information Systems, Inc.

2117 West Hoyt Ave., St. Paul, MN 55108

(612) 641-9947

Inquiry 582.

ATTORNEYS

FREE BROCHURE SOFTWARE COPYRIGHT PROTECTION IN FOREIGN COUNTRIES

If you sell or want to sell your software in other countries, write for information about international copyright, what it is and who it protects. Written for software developers, vendors, programmers, and company owners. **KNOW YOUR RIGHTS** in selling software in other countries.

DR. FREDRIC ABRAMSON, ATTORNEY AT LAW

Intellectual property and international business law
21155 Burnham Rd., Gaithersburg, MD 20879 (or)
2121 Wisconsin Ave., N.W., Suite 330, Washington D.C. 20012
Adm. in MD; not Adm. in D.C. 301-840-9733

Inquiry 586.

FREE UPS CATALOG

Protect your computer and make it last longer. Call or write today!

Best Power Technology, Inc.

World's largest manufacturer of uninterruptible power systems.

P.O. Box 280, Necedah, WI 54646
TOLL FREE (800) 356-5794 ext. 1005
or (608) 565-7200 ext. 1005

Inquiry 577.

BACKUP SYSTEMS

HD BAC-UP

THE EASIEST & FASTEST BACKUP UTILITY FOR PC/XT/AT & COMPATIBLES.

AFFORDABLE PRICE \$36.50.

EASY INSTALLATION & USE — REQUIRES NO KNOWLEDGE OF DOS — DAILY BACKUPS RUN IN A FRACTION OF THE TIME.

CALL FOR INFO & DEMO DISK 800-457-1313.

HI-TEC INDUSTRIES

6100 S. Fairfax Rd., Bloomington, IN 47401
812-824-8000

Inquiry 587.

CUT RIBBON COSTS!

Re-ink your printer ribbons quickly and easily. Do all cartridge ribbons with just one inker! For crisp, black professional print since 1982. You can choose from 3 models:

Manual E-Zee Inker — \$39.50

Electric E-Zee Inker — \$89.50

Ink Master (Electric) — \$159.00

1000's of satisfied users in 5 years. Money back guarantee.

BORG INDUSTRIES

525 MAIN ST., JANESVILLE, IA 50647

1-800-553-2404 In IOWA 319-987-2976

Inquiry 578.

SELF-INKING PRINTER RIBBON

Awarded United States Patent #4701062

Lasts 10-15 times longer than the conventional ribbon
For printers using 1/2" width open spool ribbon:

Okidata-82A-83A-84-92-93 Dec LA 180/120

Teletype-33_35 Dec LA 30/IBM 1443

Star Gemini 10X Teletype-Model 40

Extel T1 800/810, 820, 880

Contact us by mail, phone or telex and we will forward you a brochure.

CONTROLLED PRINTOUT DEVICES, INC.

POB 869, Baldwin Rd., Arden, NC 28704

(704) 684-9044 • TELEX: (FILMON-AREN) 577454

Inquiry 579.

NEW Expert System

FirstExpert - expert system generator. Ridiculously easy yet extremely powerful. No programming needed. Speed up business decisions and analysis. Information transferable to other environments. Amplifies Your Intelligence! An ingenious program for a sensational price. Many examples included.

\$99 Call or write for more information.

NovaCast Expert Systems

2530 Berryessa Rd., Suite 607, San Jose, CA 95132

(408) 272-4071 fax: (408) 437-7777

Inquiry 583.

BAR CODE

BAR CODES & BIG TEXT

On EPSON, IBM, OKI dot matrix or LaserJet. Design any format/size on ONE easy screen. 1-120 fields/label. 13 text sizes to 1" — readable at 50 ft. AIAG, MIL-STD, 2 of 5, 128, UPC/EAN, Code 39, etc. Color, Reverses, File Input, FAST—\$279. Other menu-driven bar code programs from \$49. 30 day \$ back.

Worthington Data Solutions

417-A Ingalls St., Santa Cruz, CA 95060

(800) 345-4220 In CA: (408) 458-9938

Companion and Extender

The **PS/2 COMPANION** lets you add an extra keyboard and monitor up to 150 feet away from your system unit. It comes complete with all connections and supports both color and monochrome monitors. Prices start at \$249 for a 25' unit. **EXTENDER** lets you move the keyboard and monitor up to 150 feet from the system unit. Prices start at \$149.

Cybox Corporation

2800-H Bob Wallace Ave., Huntsville, AL 35805

205-534-0011

Inquiry 580.

LISP on a MAC

Get all the functionality of the Franzlisp dialect of the Lisp language. \$20 purchases a 64K Lisp program, which will run on a MAC plus or equivalent. 1MB RAM recommended for this program. Send order to:

Oosson Software

Box 33113, Coon Rapids, MN 55433

Inquiry 584.

BAR CODE READERS

From the manufacturer for PC/XT/AT, & PS/2. Attaches as 2nd keyboard, reads as keyed data. External or bus install. With steel wand—\$399. Also Kimtron, Link, Wyse, & RS-232, Portables, Lasers, slot badge readers, and MagStripe too!
30 day \$ back.

Worthington Data Solutions

417-A Ingalls St., Santa Cruz, CA 95060

(800) 345-4220 In CA: (408) 458-9938

THE BUYER'S MART

BAR CODES

PRINT BAR CODES/BIG TEXT FROM YOUR PROGRAM

Add bar codes and big graphics text to your program. Print from ANY MS-DOS language. Bar codes: UPC, EAN, 2 of 5, MSI, Code 39, Epson, Oki, IBM dot matrix text up to 1/2". LaserJet up to 2". Font cartridges not required. \$159-\$239. 30 day \$\$ back.

Worthington Data Solutions

417-A Ingalls St., Santa Cruz, CA 95060
(800) 345-4220 In CA: (408) 458-9938

COMPLETE LINE OF BAR CODE PRODUCTS

- PrintBar II • PrintBar Softfonts
- PrintBar I • CodeScan 2000

FREE BROCHURES (916) 622-4640

Bear Rock Software Co.
6069 Enterprise Dr. Placerville, CA 95667

Inquiry 588.

BAR CODE SOLUTIONS

We make bar coding very easy with our complete line of readers. Our PC-Wand readers network, or work with your keyboard or terminal, or are carried around taking inventory, entering sales and clocking time. Our bar code label printing software packages work with MS-DOS or PC-DOS and most matrix or laser printers. We also sell pre-printed labels. Our hardware can work with nearly every computer in the world.

International Technologies & Systems Corp.
635-C North Berry St., Brea, CA 92621
(714) 990-1880 FAX: 714 990-2503 TLX 6502824734 MCI

Inquiry 589.

BAR CODE MADE EASY

PERCON® E-Z-READER® keyboard interfaces and multiuser RS-232 models make it easy to add bar code to virtually any computer/terminal WITHOUT SOFTWARE MODIFICATION. Immediate shipping. Two year warranty. Bar code printing software available. Call for details on fast, accurate, easy data entry. Substantial reseller discounts.

PERCON®

2190 W. 11th St., Eugene, OR 97402
(503) 344-1189

PC BAR CODE SPECIALISTS

Bar code readers designed for fast, reliable, cost effective data entry. Looks just like keyboard data! Choose from stainless steel wand or laser interface. Also, powerful Bar Code and Text printing software. Great warranty. Dealer inquiries welcome.

Seagull Scientific Systems

15127 N.E. 24th, Suite 333
Redmond, WA 98052

BAR CODE READERS

Among the industries best and most widely used barcode reader, reads all major barcode formats (code 39, 2 of 5, UPC/EAN, codabar), connects between keyboard & system, advanced CMOS uses keyboard power supply, connects to all IBM compatibles and DIN terminals, completely OS independent, software independent. Same day ship, 1 year warranty, 30 day satisfaction guarantee. CALL for prices too low to advertise.

Solutions Engineering Sales

8653 Georgia Ave., Silver Spring, MD 20910
800-635-6533

Inquiry 590.

BAR CODE

DATA INPUT DEVICES

Bar Code & Magnetic Stripe Readers for microcomputers & terminals, including IBM PS/2 & others, DEC, AT&T, CT, Wyse, Wang. All readers connect on the keyboard cable & are transparent to all software. Low cost bar code print programs & magnetic encoders are also available. GSA contract #GS00K87AGS5346.

TPS Electronics

4047 Transport, Palo Alto, CA 94303
415-856-6833 Telex 371-9097 TPS PLA

Inquiry 591.

BBS/PUBLIC DOMAIN

350+ New Titles Added Each Month

18+ Special Interest Forum message bases plus Real Time Conferencing. USA TODAY Decision-Line News Service. Quarterly Newsletter & BBS System Users Guide. PC Pursuit Accessible. Fee: \$10/3 Mo. — \$25/Yr.

9 Incoming lines. **FREE DEMO MODE**
(503) 761-8100 12/2400 N,8,1
RANDOM ACCESS Information Network
P.O. Box 16675, Portland OR 97216

Inquiry 592.

CAD/CAM

\$39.95 CAD

Fully featured, symbols, auto dimensioning, hatching, fillets, reads DXF, handles all but the largest drawings. Extremely powerful BASIC-like macros, on line manual plus so much more. Requires IBM XT/AT/PS2 with 640K and hard disk. 20,000 new users this year.

PAFEC INC.

5550 Technology Park, Norcross, GA 30092
1-800-52PAFEC (404) 441-9300

Inquiry 593.

CASE

Affordable CASE

A new concept in Computer Aided Engineering for developing PC/DOS applications! C Dispatcher generates fast, efficient C code for command and menu driven applications. Develop, document, and change easily. Many features. For many compilers. \$295.00 MC/Visa

Amaryllis Inc.

563 Wattaquodoc Rd., Bolton, MA 01740
(617) 365-5456

Inquiry 594.

FINITE STATE PROGRAM COMPILERS

Develop & document software faster, as state programs that execute quicker & use less memory: Ada, Basic, C, Fortran & Pascal.

IBM PC, XT, AT, PS/2 200K RAM Dos 2.0+
Price: \$175.00 per language (With Primer and Debugger)
AYECO 5025 Nassau Circle, Orlando
INCORPORATED FL 32808 (407) 295-0930

Inquiry 595.

PROTOTYPING TOOL

Build a working system model of your application with PC-PROTO. Very Fast. Very Flexible. No Programming Required. Screen Painter. Data Base Manager. Generate data dictionary, source code, documentation, programming specifications. Suitable for JAD as well. For PC, XT or AT. From \$149.00. MC/VISA.

Kärtech, Inc. (416) 656-2032
165 Pinewood Ave., Toronto, Ontario, Canada M6C 2V6

Inquiry 596.

CD/ROM

CD-ROM Drives & Titles Largest selection for PC & Mac.

Drives from \$699. Hundreds of titles from \$29.

Money-back Guarantee.

MC/VISA/AMEX accepted.

Call or write for free 88 page catalog.

Get it all from "The Bureau"

Bureau of Electronic Publishing
121 Norwood Ave., Upper Montclair, NJ 07043

(201) 746-3031

Inquiry 597.

Public Data on CD-ROMs

- Econ/Stats I — Prices, Employment
- Consu/Stats — BLS/Census 1984 consumer data
- Agri/Stats — Agricultural series
- Makes tables, DIF, or ASCII
- \$49 each, req. MS-DOS
- CD-ROM publishing services available

Hopkins Technology

421 Hazel Lane, Hopkins, MN 55343
(612) 931-9376 Compuserve 74017,614

Inquiry 598.

COMMUNICATIONS

MULTI-LINE PC-DOS BBS

The Bread Board System (TBBS). Secure, reliable, full-featured commercial information system for IBM XT/AT/386/PS2 or compatible. Menu editor allows customization by nonprogrammers. Kermit, X & Y. Modem. High performance allows up to 32 simultaneous callers. User audit trail. 300/1200/2400/9600 bps.

eSoft, Inc.

15200 E. Girard Ave. #250, Aurora, CO 80014
(303) 699-6565

Inquiry 599.

Bi-Directional File X-fers

Multi-Com telecommunications program offers the following.....

- Simultaneous Downloading/Uploading
- Send/Receive Console Messages During File Transfers
- 100% Line Utilization During Multi-File Transfers
- Uses Full Duplex ADLC Protocol
- More Efficient Than Xmodem, Kermit, etc.
- Saves Time and Cuts Connect Costs

Information & 5 1/4" Demo Disk \$500 + \$3 s/h

Program Pkg., 3 1/2" & 5 1/4" disks, manual \$49.95 + \$4 s/h

Multiplex Systems (412) 276-3374 24 hrs.

P.O. Box 16174, Pittsburgh, PA 15242

Inquiry 600.

FAX MACHINES \$395

MURATA FAX 1200/1800 \$795/925
SHARP FAX F0300/F0500 \$1195/1495
TOSHIBA FAX 30100/33000/3700 \$1088/1240/CALL
RICOH 10/20 \$1295/1595
CANON FAX 20 \$1279
PC/XT SYS.Receive/Transmit FAX+Scanner \$1595
PC/XT Telephone Answer & Voicemail \$1595

Prepay prices Visa/MC 2% cod 2% restock 20%

TELEPHONE PRODUCTS CENTER

23591 #213 El Toro Rd., El Toro, CA 92630 714/739-9555

Inquiry 601.

COMPUTER INSURANCE

INSURES YOUR COMPUTER

SAFEWARE provides full replacement of hardware, media and purchased software. As little as \$39 a year provides comprehensive coverage. Blanket coverage; no list of equipment needed. One call does it all. Call 8 am-10 pm ET. (Sat. 9 to 5)

TOLL FREE 1-800-848-3469

(Local 614-262-0559)

SAFEWARE, The Insurance Agency Inc.

Inquiry 602.

THE BUYER'S MART

COMPUTER RENTALS

RENTALS

WEEKLY MONTHLY YEARLY

\$189 PER MO.
**IBM - APPLE
 COMPAQ**
 Full Stock/Next Day Delivery
 Free Service & Maintenance
800 PC-RENTL
 IBM PS/2 Model 50

Inquiry 603

CROSS ASSEMBLERS

CROSS ASSEMBLERS

Universal Linker, Librarian
Targets for 36 Microprocessors
 Hosts: PC/MS DOS, micro VAX, VAX 8000
 Developed and supported at:
ENERTEC, INC.
 BOX 1312, Lansdale, PA 19446
215-362-0966 MC/VISA

Inquiry 604.

Professional Series

PseudoCode releases it's PseudoSam Professional Series of cross assemblers. Most popular processors. Macros, Conditional Assembly, and Include Files. Virtually unlimited size. For IBM PC's, MS-DOS 2.0 or greater. With manual for \$35.00. Each additional \$20.00. (MI res. 4% tax). Shipping \$5, Canada \$10, Foreign \$15. Visa/MC. (Dealer Inquiries Welcome).

Kore

6910 Patterson, Caledonia, MI 49316
616-791-9333

Inquiry 605.

FANTASTIC SIMULATORS

For the 8048, 8051, 8080, 8085, & Z80 families. Full function simulation including ALL MODES of interrupts. Built-in disassembler. Better than expensive I.C.E.'s.

CROSS ASSEMBLERS

We support the 8048, 8051, 8080/8085, 8096 & Z80 families. Just \$75 each.

Lear Com Company

2440 Kipling St./Ste. 206, Lakewood, CO 80125
303-232-2226

Inquiry 606.

CROSS ASSEMBLERS

Macros, PC Compatible, Relocatable, Conditionals, Fast, Reliable from **\$150**
 also: Disassemblers
 EPROM Programmer Board

MICROCOMPUTER TOOLS CO.

Phone (800) 443-0779

In CA (415) 825-4200

912 Hastings Dr., Concord, CA 94518

Inquiry 607.

680X0 Cross Assemblers

Now, inexpensive quality 680X0 Cross Assemblers that use your IBM PC or compatible. All versions include extensive listing facilities, up to 32 char labels, sorted symbol tables, INCLUDE files, PATH names, ORG, DC, DS, EQU, many other directives (except MACROS), printed manuals. Basic versions create S-records. Linking versions create either S-records or relocatable modules, and include a linker which creates S-records or binary output files. Not copy protected. Minimum requirements are 320K, DOS 2.0X, & 1-1/4" DSD. Basic 68000/68010—\$49.95 Linking 68000/68010—\$89.95 Basic 68020—\$69.95 Basic 68020/68881—\$129
 Checks, VISA, MC accepted. MN residents + 6% sales tax. No PO's or COD's, please.

RAVEN Computer Systems

Box 12116, St. Paul, MN 55112 (612) 636-0365

Inquiry 608.

CROSS ASSEMBLERS

Z80/HD64180

SLR Systems cross assemblers run on PC and are compatible with Microsoft M80/L80. \$195.00 for assembler and linker. We have CP/M emulator cards for PC. Up to 12.5 mhz Z80 clock speed, starting at \$249.95! Also Z80/HD64180 C compilers.

Z-World

1772 Picasso Ave., Davis, CA 95616 (916) 753-3722
 Please see our ads on page 442.

Inquiry 609.

DATA ACQUISITIONS SYS.

IT'S ABOUT TIME

Finally, a low cost (\$200) data acquisition system that's easy to talk to, (RS232/RS485). Use it for security systems, energy management, process control, education or home projects. Up to fifteen boards per serial port. Many low cost options available.

Specs:

8-8 bit A/D chnls, 8 digital I/O, prog. counter/timer, 12-24 Vdc power.

DA/M Corp. Ltd.

#140 17303-102 Ave., Edmonton, Alberta, CANADA, T5S 1J8
 403-486-3534 FAX 403-486-3535

Inquiry 610.

DATA CONVERSION

MEDIA CONVERSION/DATA TRANSLATION

More than just a straight dump or ASCII transfer!
Word Processing, DBMS, and Spreadsheet data on Disks or Tapes transferred directly into applications running on Mainframes, Minis, Micros, Dedicated Word Processors, Typesetters, and Electronic Publishing systems.
 IBM PS/2 & Macintosh supported
 #1 in the translation industry!

CompuData Translators, Inc.

3325 Wilshire Blvd., Suite 1202, Los Angeles, CA 90010
 (213) 387-4477 1-800-825-8251

Inquiry 611.

CONVERT

W-2's AND 1099's

TO MAGNETIC MEDIA

FOR IRS

FROM 75¢ PER RECORD

APPROVED SERVICE BUREAU

* * *

DataCopy Service of Texas

3306 W. Walnut #400, Garland, Texas 75042
 (214) 272-7751

Inquiry 612.

DATABASE MGMT SYSTEMS

SOFTWARE KIT PACKAGING

OEM supplier to one of the world's largest computer companies offers quality packaging and supplies for your software products. From diskettes to printed manuals. Quality products reflecting your company's image is our highest priority. Call or write.

COMPUTER LOGICS LIMITED

4845 Transit Road Unit K-8, Depew, NY 14043
 (716) 633-2810 Fax (716) 633-2813

Inquiry 613.

ID_ENTITY RELATIONAL DBMS

Full relational power without programming. Retrieve data in multiple tables easily. Modify table structures to speed queries. Import & Export data fast. Report writer. ID_ENTITY makes relational tasks other DBMS's avoid EASY. \$295 Reg. For limited time \$99 plus UPS.

Horizons Unlimited & Assocs.

1786 Michael Lane, Pacific Palisades, CA 90272
 (213) 454-4178

Inquiry 614.

DATABASE MGMT SYSTEMS

FREE TRIAL dBASE III CLON!!

"1 on 1 is a programmable relational DBMS. . . The menu mode is a fancier and more complete version of DBases's assistant mode. . . 1 on 1 = 3!! is a great deal for those who would be glad to have a dBASE III PLUS clone!"

** PC MAGAZINE 5/17/88 **

Free 30 day trial full program USA only or Buy now get free upgrade. Money back guarantee \$69 + \$5. S/H chkl/Amex. CAN +\$4. Other +\$10. Call or write:

1 on 1 Computer Solutions

26 Finchwood Dr., Trumbull, CT 06611 203-375-0914
 dBASE III is a trademark of Ashton-TATE

Inquiry 615.

DATA/DISK CONVERSION

QUALITY CONVERSIONS

• Disk • Scanning • Tape

*TYPEWRITTEN \$33 per page to ASCII

*TYPESET 6-24 point Low Rates

(*WP Formats available)

IMAGES

Logos/Line Art/Glossies

1st Run Computer Services Inc.

1261 Broadway, Suite 508, New York, NY 10001

(212) 779-0800

Inquiry 616.

Get the Expertise You Need!

Disk/Disk • Tape/Disk • OCR

Over 1,000 formats! 3 1/2, 5 1/4, or 8 inch disks; 9 track mag tape; 10 MB Bernoulli cartridge. Data base and word processor translation. Specialists in Government Security Data. Call for free consultation.

Computer Conversions, Inc.

9580 Black Mtn. Rd., Ste J, San Diego, CA 92126

(619) 693-1697

Inquiry 617.

DISK CONVERSIONS

Media transfer to or from: IBM, Xerox, DEC, Wang, Lanier, CPT, Micom, NBI, CT, also WP, WS, MS/WRD, DW4, MM, Samna, DEC DX, MAS 11, Xerox-Writer, ASCII.

FREE TEST CONVERSION

CONVERSION SPECIALISTS

531 Main St., Ste. 835, El Segundo, CA 90245
 (213) 545-6551 (213) 322-6319

Inquiry 618.

DISK & TAPE CONVERSIONS

AUTOMATICALLY

SAVE TIME AND MONEY

Over 1000 formats from Mini, Micro Mainframe, Word Processors, & Typesetters.

TAPE Conversions as low as \$2300 MB

DISK Conversions as low as \$15.00 per Disk

Call or write TODAY for a cost saving quotation.

CREATIVE DATA SERVICES

1210 W. Latimer Ave., Campbell, CA 95008

(408) 866-6080

Inquiry 619.

DISK INTERCHANGE

SERVICE COMPANY

DISC specializes in transferring files between incompatible disk formats, and between disk and 9-track tape.

- Dedicated Word Processors
- Mini, Micro & Mainframe Computers
- 9-Track Tape (800, 1600 and 6250 BPI)
- MSDOS, CP/M, UNIX, DOS, PRODOS, TSX +, RT-11

2 Park Drive • Westford, MA 01886

(617) 692-0050

Inquiry 620.

THE BUYER'S MART

DATA/DISK CONVERSION

RUN HP SERIES 80 PROGRAMS ON IBM PC

Translator allows users to move programs written on Hewlett Packard 85, 86, 87, 9915 to IBM PC, AT, PS/2, compatibles and run them on Microsoft's powerful QuickBASIC 4.0. File copy utility included. HP BASIC program translation and disk file copy to PC's our specialty. Call us.

Oswego Software 312/554-3567
507 North Adams St. FAX 312/554-3575
Oswego, Illinois 60543 TELEX 858757

Inquiry 621.

CONVERSION SERVICES

Convert any 9 track magnetic tape to or from over 1000 formats including 3 1/2", 5 1/4", 8" disk formats & word processors. Disk to disk conversions also available. Call for more info. Introducing OCR Scanning Services.

Pivair Computing Services, Inc.
165 Arlington Hgts. Rd., Dept. #B
Buffalo Grove, IL 60089 (312) 459-6010

Inquiry 622.

DEMOS/TUTORIALS

INSTANT REPLAY III

Build Demos, Tutorials, Prototypes, Presentations, Music, Timed Keyboard Macros, and Menu Systems. Includes Screen Maker, Keystroke/Time Editor, Program Memorizer, and Animator. Rec'd Great Reviews! Simply the BEST! Not copy protected. No royalties. 60 day satisfaction money back guar. IBM and Compat. \$149.95 U.S. Chk/Cr. Crd. Demo Diskette \$5.00

NOSTRADAMUS, INC.
3191 South Valley Street (ste 252)
Salt Lake City, Utah 84109 (801) 487-9662

Inquiry 623.

DESKTOP PUBLISHING

HIGH RESOLUTION MONITOR

- Desktop Publishing and CAD low cost graphics subsystem
- Workstation Resolution for your IBM PC/XT or AT compatible
- 1024 x 768 paper white 14" flat screen
- Drivers for Ventura, Page Maker, Windows, GEM and AutoCAD
- Can coexist with another color graphics adapter
- Call NOW \$595 including graphics board, monitor and software
- VISA and MasterCard accepted

CATI INC
16840-B Joleen Way, Morgan Hill, CA 95037
HOT LINE 408-778-CATS

Inquiry 624.

Desktop Publishers!

When you need the best "no-nonsense" tools for **Screen Capture and Image Management**

Collage Display Utilities

Dynamic Grayscale, Image Browsing and Cataloging, and much, much more! Supports EGA, VGA, PS/2, CGA, Hercules, and MDA displays!

Suggested Retail price, only **\$89⁹⁵**
Inner Media, Inc. (603) 465-3216, -7195 Fax

Inquiry 625.

DISK COMPATIBILITY

IBM PC's USE Mac DISKS

MatchMaker lets you plug any Macintosh external floppy drive into an IBM PC. Half size card and software lets you copy to/from, view directory, initialize, or delete files on the Mac diskette. Works with PCs, XT's, AT's, and compatibles. *The easy way to move information!*

\$149.00 Visa/MC/COD/Chk.
Micro Solutions Computer Products
132 W. Lincoln Hwy., DeKalb, IL 60115 815/756-3411

Inquiry 626.

DISK DRIVES

HARD DISKS

MN6128	110 MB	28MS	\$699.
MN9380E	338 MB	16MS	\$2399.
MN6085	71 MB	28MS	\$545.
MC1355	150 MB	23MS	\$1299.
MC1335	71 MB	28MS	\$545.
ST4096	80 MB	28MS	\$525.
ST251	40 MB	40MS	\$329.
ST251-1	40 MB	28MS	\$379.

CPU INC (714) 870-9033

Inquiry 627.

PS/2 DRIVES FOR PC's AT's

CompatiKit/PC	\$329
CompatiKit/AT	\$269

Built-in floppy controllers—no problem. Supports multiple drives and formats. Lets your computer use IBM PS/2 1.4M diskettes *plus more!* Call for further information or to place an order. *VISA/MC/COD/CHECK.*

Micro Solutions Computer Products
132 W. Lincoln Hwy., DeKalb, IL 60115 815/756-3411

Inquiry 628.

DISK DUPE EQUIPMENT

DO YOUR OWN DUPLICATION

Copy 10,000 or only 10 in as little as 15 seconds each with famous Mountain Duplication equipment at the very best prices!! See us for all of your duplication equipment needs from Disks to Drives to Duplicators.

SYSTEMS SUPPORT DATA
223 North Royal Avenue, Front Royal, VA 22630
1-800-231-4355

Inquiry 629.

DISK DUPLICATION

SOFTWARE PRODUCTION

- Disk duplication
- All formats
- EVERLOCK copy protection
- Label/sleeve printing
- Full packaging services
- Warehousing
- Drop shipping
- Fulfillment
- 48-hour delivery
- Consultation & guidance

Star-Byte, Inc.
713 W. Main St., Lansdale, PA 19446
215-368-1200 800-243-1515

Inquiry 630.

DUPLICATION IS THE SINCEREST FORM OF FLATTERY

Let us Flatter you!!! See us for all disk duplication needs. 10 disks to 100,000 and more All formats—All systems. Best prices—Our own in-house printing of documentation—labels-sleeves.

SYSTEMS SUPPORT DATA
223 North Royal Avenue, Front Royal, VA 22630
1-800-231-4355

Inquiry 631.

DISKETTES

CHEAP DISKS!!!

Although this headline may not convey quality. . . . our 3 1/2" floppy disks do!

100% Certified
720k only 98¢
1.44 MEG only \$2.60

SYSTEMS SUPPORT DATA
223 North Royal Avenue, Front Royal, VA 22630
1-800-231-4355

Inquiry 632.

DUPLICATION SERVICES

SOFTWARE DUPLICATION

- One Stop Shopping
- Custom Packaging
- Copy Protection
- Technical Support
- Drop Shipping
- Fast Turnaround
- Competitive Pricing

SATISFACTION GUARANTEED
800-222-0490 NJ 201-462-7628

MEGAsoft

P.O. Box 710, Freehold, NJ 07728 See our ads on page 440.

Inquiry 633.

ELECTRONIC PROJECTS

BUILD TALKING ROBOT!

- Build B.E.R.T.© the Basic Educational Robot Trainer
- Featured in BYTE April & May / 87
- Even a child can program this talking Robot, built from off-the-shelf components
- Minimum Kit \$500.00 U.S.
- Complete Kit \$180.00 U.S.
- +10% S/H VISA welcomed
- For further information write to:

GoCo Dist.
Suite 806, 1146 Harwood St., Vancouver, B.C. Canada V6E 3V1
VISA orders only: 604-681-0595

Inquiry 634.

ENTERTAINMENT

★ ★ CHESS SPECTACULAR! ★ ★

At last a chess program designed for the new graphics standard. High resolution animation brings your EGA to life! Solves mate in 7. Huge opening book. Save/restart your games. Animated teaching mode. Select level. Take back/Change sides. On screen clock. **MUCH MORE! EGA Chess \$69.95 256K EGA/VGA 5.25" disk. VISA/MC**

CUBE Microsystems
P.O. Box 26064, Overland Park, KS 66225
(913) 649-6747

Inquiry 635.

HOOKED ON BLACKJACK?

Blackjack Players—improve your play with an inexpensive but good (IBG) Blackjack program. Plays ALL Casino games and options. Blackjack V1.00 includes: • on-line basic strategies • simple card counts. For you card-counters there is a Pro-Player Upgrade feature that allows YOUR card counts and YOUR strategies. Machine requirements: • IBM/PC compatible (256K) • PC-DOS V2.0 or later. • BLACKJACK program \$20.00 Pro-Player Upgrade add \$12.50 (Specify diskette size) Money back guarantee 30 days — allow 4 weeks for delivery. Mail check or money order to: (FL res. add 6%)

IBG SOFTWARE
P. O. Box 27-6354, Dept. B, Boca Raton, FL 33427-6354

Inquiry 636.

NEMESIS™ Go Master™

Go is a popular Oriental game of intellectual complexity and elegance. NEMESIS, recognized worldwide as the best Go program, is an ideal playmate and tutor. Pournelle's game of the month *twice*. "If you are interested in Go, buy this program." BYTE 7/87

Toyogo, Inc.
76 Bedford St., Ste. 34Y, Lexington, MA 02173
(617) 861-0488

Inquiry 637.

80 programs for IBM PC

Games, quizzes, trivia, utilities, antiviral, programming techniques, how to use DOS and BIOS. All in super fast assembly language. Includes source code and software license. DISK1—360K \$5 720K \$6 Book—\$18

Zipfast electronics
Box 12238, Lexington, KY 40581-2238

Inquiry 638.

THE BUYER'S MART

FLOW CHARTS

FLOW CHARTING II+ HELPS YOU!

Precise flowcharting is fast and simple with Flow Charting II+. Draw, edit and print perfect charts: bold and normal fonts, 26 shapes—95 sizes; fast entry of arrows, bypasses & connectors; Fast Insert Line; shrink screen displays 200-column chart; 40 column edit screen for detail work, much more!

PATTON & PATTON

81 Great Oaks Blvd., San Jose, CA 95119

1-800-525-0082 (Outside CA)

408-629-5376 (CA/Int'l)

Inquiry 639.

HARDWARE

TRAPPED BY YOUR ROM BIOS?

Update your PC/XT, 286 or 386 machines with the latest ROM BIOS from AWARD Software. Supports Enhanced Keyboards, VGA Graphics, Fast Processor Speeds, 35" Floppies, Networking, etc. Authorized Award Distributor

Call 1-800-423-3400

KOMPUTERWERK, INC.

851 Parkview Blvd., Pittsburgh, PA 15215

Inquiry 645.

INVENTORY MANAGEMENT

STOCK-MASTER 4.0

Commercial grade inventory management software at micro prices.

- Supports all 12 transaction types
- Trend Analysis
- Quality Control
- Multiple Locations
- Purchase Order Tracking
- Open Order Reporting
- Serial/Lot # Tracking
- Stock Status Reporting
- Activity History Analysis
- Bill of Materials
- Purchase Order Writing
- Order Entry
- Material Requirements
- On Line Inquiry

Applied Micro Business Systems, Inc.

177F Riverside Ave., Newport Beach, CA 92663 714-759-0582

Inquiry 651.

STRUCTURED FLOW CHART

NSChart creates Nassi-Shneiderman (structured) flowcharts from a simple PDL. Keywords define structures & text strings appear in the chart. Easy to create, even easier to revise! Automatic chart sizing, text centering. Translators from many languages available. For Mac and IBM PC.

SILTRONIX, INC.

P.O. Box 82544, San Diego, CA 92138

1-800-637-4888

Inquiry 640.

BUY ★ SELL ★ TRADE

Apple • Service Parts

- Accessories • Systems •

PRE-OWNED Electronics, Inc.

30 Clematis Avenue, Waltham, MA 02154

800-274-5343 FAX 617-891-3556

Service Centers and Dealers welcome

Inquiry 646.

HARDWARE

CHIP CHECKER

- 74/54 TTL + CMOS • 8000 Nat. + Signetics
- 14/4000 CMOS • 9000 TTL
- 14-24 Pin Chips • .3" + .6" IC widths

Tests/identifies over 650 digital chips with ANY type of output in seconds. Also tests popular RAM chips. IBM compatible version \$259. C128 + C64 version \$159.

DUNE SYSTEMS

2603 Willa Dr., St. Joseph, MI 49085

(616) 983-2352

Inquiry 641.

MEET with HERMIS™ SCI

A PC Digital Voice Recording/Reproduction System Adapter.

Features:

- a.) PC Half Card Size
- b.) LSI Voice Processor
- c.) 256K Memory
- d.) Record at 8K, 11K, 16K or 32Kbps
- e.) Mic, Headphone and Speaker Included
- f.) Bell 212A Model I/F
- g.) Full Software Control
- h.) Demo software written in 'C'

All features under \$600.00 + s&h VISA/MC

Sensory Communications, Inc.

800 Fawn Valley Dr., Allen, TX 75002

(214) 727-9385

Inquiry 647.

LAPTOP COMPUTERS

LAPTOP SPECIALS

Toshiba • Zenith • NEC • DATAVUE • SHARP • NEW! Hard drives available for Tandy 1400 LT & Toshiba 1100+ • AFFORDABLE 5 1/4" or 3 1/2" DRIVE UNITS for LAPTOPS & DESKTOPS • DICONIX PRINTERS • 788 card for T1000 • 2400 BAUD MODEMS for Laptops • Fast reliable and friendly service. For Low Pricing call

COMPUTER OPTIONS UNLIMITED

201-469-7678 (7 Days, 9 am-10 pm Eastern time)

Inquiry 652.

INDUSTRIAL STRENGTH SINGLE BOARD COMPUTER

Has optimum features for monitor + control applications: 16 Chan A/D • 4 RS232C/422 Ports • 48 Prog I/O Lines • 8 Opto INs • 8 HiDrive OUTs • 4 Timers • Watchdog • 104K Memory • 5.25 x 80 Options: Resident FORTH OS with Target Compiler, Editor, Assembler, + Auto Load/Start; 5 MHz 8085 • 4 Chan D/A • Battery Backed Clock/RAM • Networking • PC Support.

E-PAC 1000 + \$249.00 E-PAC 2000 + \$449.00

EMAC INC.

P.O. Box 2042, Carbondale IL 62902 (618) 529-4525

Inquiry 642.

68000 / 68020 / 68881 COMPLETE DEVELOPMENT SYSTEM

for the 68000, 68020 and 68881 chips—includes the chips, power supply, serial interface with software, 68000/68020 cross assembler (hosted on a PC), documentation, schematic, Operating System, cables. Special Price—\$1100.00

Phone URDA, Inc.

1-800-338-0517

Inquiry 648.

FREE CATALOG

Protect your computer power from black-outs, brown-outs, audio/video hash and surges! Complete line of low cost Emergency Power Supply units, Line Conditioners and Surge Suppressors prevent damage and loss of valuable data. Prevent errors, malfunctions and false printouts! Send for money saving catalog today.

INDUS-TOOL

730 W. Lake St., Chicago, IL 60606

Phone 312-648-2191

Inquiry 643.

HARDWARE/COPROCESSOR

SC/FOX™ PARALLEL COPROCESSOR

PC/XT/AT/386 plug-in board with Forth software. 10 MIPS operation, up to 50 MIPS burst. 64K to 1M byte memory. Uses Harris RTX 2000™ RISC realtime CPU with 1-cycle multiply, 1-cycle 14-priority interrupts, two 256-word stacks, three 16-bit timer/counters, 16-bit I/O bus. Ideal for real-time control, signal and image processing and multiple board operation. From \$1,995.

SILICON COMPOSERS, INC. (415) 322-8763

210 California Ave., Suite K, Palo Alto, CA 94306

Inquiry 649.

LAP-LINK

The ultimate solution for linking laptop computer with any IBM compatible desktop PC. 115,200 baud transfer rate—faster than any other product available. No installation necessary, easy to use split screen design. Includes incredible "universal cable" that connects any two computers. Transfer entire disks faster than a DOS copy command! Only \$129.95 including universal cable and both 3 1/2" and 5 1/4" disks. "Bridge" owners can trade in for only \$89.95 w/o cable.

Traveling Software, Inc.

18702 North Creek Parkway, Bothell WA 98011

1-800-343-8080 (206) 483-8088

Inquiry 654.

IMAGE PROCESSING

ZIP Image Processing

ZIP brings video image processing to the PC. Control ImageWise video digitizer, use 1 or 2 serial ports to capture/display images from any video source. Outstanding image display on EGA/EEGA/VGA in color and 64 gray levels.

Call (314) 962-7833 for VISA/MC, or send check \$79 + \$2 s/h. MO add 5.8%.

Hogware Company

470 Belleview, St Louis, MO 63119

(314) 962-7833

Inquiry 650.

LEGAL

LEGAL DOCUMENT MAKER

All pleadings and documents.

Any word processor software.

Free Brochure.

New! Supra II™.

TSC - The Software Company

P.O. Box 872687, Wasilla, AK 99687

(907) 373-6550

Inquiry 655.

PC CARDS/KITS

- 8 bit A/D card, 0-5V \$79
- 8 bit D/A card, 0-2.5V \$79
- Relay driver card, 8 outputs (3A) \$149
- Digital I/O (8 TTL Input/output) \$79
- JB XT computer kit w/monitor \$499
- FREE CATALOG—parts, kits, computers

JB COMPU-TRONIX

3816 N. Wadsworth Blvd., Wheat Ridge, CO 80033

(303) 425-9586

Inquiry 644.

THE BUYER'S MART

MAGAZINES ON DISK

COMBINATION SAMPLER 3 PC PRODUCTS - 4 DISKS - \$29

* **MAGAZETTE** — software for the whole family! Programs for education, recreation, home and business. \$14.85, 2 disks!
* **PC GAMES** — just for the fun of it! Every issue loaded with recreational software for all ages. \$9.95.
* **PC DISK QUARTERLY** — every issue a special edition! Tutorials and interactive books-on-disk. \$19.95.

SAMPLER: one of each (4 disks) only \$29—save over \$15.
CALL TOLL-FREE: VISA/MC/AmEx: **800-551-8383**
ext. 3210

I.B. Magazette 425 Edwards #1306, Shreveport LA 71101

Inquiry 656.

MARKETING

FREE BROCHURE & CATALOG

If you have a computer product that you're marketing... or thinking about marketing... we can help. We'll help you get free publicity from computer magazine editors, user groups and computer stores. Send for a free brochure today.

DP Directory, Inc.

525 Goodale Hill Road, Ste. 410, Glastonbury, CT 06033
(203) 659-1065

Inquiry 657.

MEMORY CHIPS

MEMORY CHIPS

41256-15-12-10.....	Call	51000 (1 Meg).....	Call
4164-15.....	Call	51258 for Compaq 386.....	Call
4164-12.....	Call	8087-3-2.....	Call
41126 Piggy Back for AT.....	Call	80287-6-8-10.....	Call
41464-12 (84Kx4).....	Call	80387.....	Call
414256 (256Kx4).....	Call	NEC-V-20-B.....	Call
2764,27128,27256,27512.....	Call	Mouse.....	Call

Prices subject to change

ESSKAY 718-353-3353

Inquiry 658.

MONITOR INTERFACE

DRIVE MULTIPLE MONITORS

with one PC using our VOPEX video port expanders. Featuring no loss of resolution or color, presentations are more dramatic. We have a VOPEX for PC, PS/2, MAC II & workstations. Units are available from 2 to 10 output ports.

NETWORK TECHNOLOGIES INC.

800-RGB-TECH or 216-543-1646 MC/VISA/AMEX
19145 Elizabeth St., Aurora, OH 44202

Inquiry 659.

PROGRAMMERS TOOLS

C or T Pascal Code Instantly

Complete database in just minutes. Draw & Paint your screen, show what fields to use for indexes—That's it—running source code in 6 seconds. Automatic context sensitive help, programmer docs on each program. \$389/TPascal ver. or \$499/TC or MS-C ver.

Call ASCII (800) 227-7681

Inquiry 660.

TLIB™ 4.0 Version Control

The best gets better! They loved TLIB 3.0: "packed with features... [does deltas] amazingly fast... excellent"—PC Tech Journal Sept 87. "has my highest recommendation"—R. Richardson, Computer Shopper Aug 87. Now TLIB 4.0 has: branching, more keywords, wildcards & file lists, revision merge, LAN and WORM drive support, more. MS/PC-DOS 2.x & 3.x \$99.95 + \$3 s&h. Visa/MC.

BURTON SYSTEMS SOFTWARE

P.O. Box 4156, Cary, NC 27519 (919) 856-0475

Inquiry 661.

PROGRAMMERS TOOLS

FORTRAN NAMELIST EMULATOR

NAMLST™ subroutine library provides Fortran programmers with an emulation of NAMELIST and associated read and write routines. Supports Fortran 77 data types, 31 character names, control of output line length, tab stops, paging, plus features not found in compilers with NAMELIST statements. Popular Fortran 77 compilers. Literature available. Price \$150.

Data Ready

4647 T Highway 280 E—Suite 150, Birmingham, AL 35242
(205) 991-6381

Inquiry 662.

DEVELOPMENT TOOLS

Professional Programmers Extender: Standard Mac interface, lists, printing, graphics, tiling. Extender GraphPac: Quality color graphs. Line, bar, semi-log, customizable symbols.

INVENTION SOFTWARE (313) 996-8108

Inquiry 663.

TURBO PLUS \$99.95

Programming tools for Turbo Pascal 4.0 Screen Painter, Code Generator, I/O Fields, Dynamic Menus, Programming Unit Libraries, Sample Programs, 280 Page Illustrated Manual. 60 Day Satisfaction Guarantee! Brochures & Demo Diskettes avail. Highly Favorable Reviews! IBM & Compatibles.

Nostradamus Inc.

3191 South Valley St. (Suite 252) Salt Lake City, UT 84109
(801) 487-9662

Inquiry 664.

Get INSIDE!

INSIDE! is a powerful software performance analysis tool for popular PC compilers. INSIDE! measures the execution time of every function or procedure with microsecond accuracy or computes how often each source line is executed. Simply compile your application and INSIDE! does the rest. \$75

Paradigm Systems Inc.

P.O. Box 152, Milford, MA 01757
(800) 537-5043 In MA: (508) 478-0499

Inquiry 665.

Modula-2

Graphics brings the widely used MetaWindow professional graphics library to users of JPI TopSpeed, Logitech, and other M2 compilers. Supports multiple fonts, image scaling, mouse tracking, many printers, and over 30 display adapters. Call for free demo. Only \$149 (\$189 with source). Includes MetaWindow package. From the creators of Repertoire (\$89), NetMod (\$69), Dynamatrix (\$69), EmsStorage (\$49), etc. MC/VISA/AMEX/COD.

PMI 4536 SE 50th, Portland, OR 97206
(503) 777-8844; TLX: 650-2691013

Inquiry 666.

FREE BUYER'S GUIDE

Programmer's Connection is an independent dealer representing more than 300 manufacturers with over 800 software products for IBM personal computers and compatibles. We have serviced the professional programmer since 1984 by offering sound advice and low prices. Call or write today to receive your FREE comprehensive Buyer's Guide.

Programmer's Connection US 800-336-1166
7249 Whipple Ave. NW Canada 800-225-1166
North Canton, OH 44720 International 216-494-3781

Inquiry 667.

PROGRAMMERS TOOLS

DISASSEMBLERS

MPU OBJECT CODE on your PC

Relocatable, symbolic disassemblers are now available for the Motorola, Intel, RCA, TI, Rockwell, & Zilog micro! Automatic label generation, assembly capability and much more. Call and ask for what you need.

RELMS™

P.O. Box 6719, San Jose, CA 95150
(408) 356-1210

TWX 910-379-0014 (800) 448-4880

Inquiry 668.

PUBLIC DOMAIN

OUTSTANDING IBM SOFTWARE ONLY \$2.75/DISK OR LESS

Our collection contains the latest versions of the Best Shareware and Public Domain Programs. Most are menu driven with full documentation. 350" format is also available. Orders shipped First Class Within 24 hours and Satisfaction is guaranteed. Write for free printed catalogue or send a 25¢ stamp for a disk catalogue.

A.C.L. (916) 973-1850

1621 Fulton Ave., Suite #35-B, Sacramento, CA 95825

Inquiry 669.

\$3.00 SOFTWARE FOR IBM PC

Hundreds to choose from, wordprocessors, databases, spreadsheets, games, lotto, communications, business, music, bible, art, education, language and useful utilities for making your computer easier to learn. Most programs have documentation on the disk.

WRITE FOR YOUR FREE CATALOG TODAY!

BEST BITS & BYTES

P.O. Box 8245, Dept. B, Van Nuys, CA 91409

In CA: (818) 781-9975 800-245-BYTE

Inquiry 670.

FREE SOFTWARE BEST OF PUBLIC DOMAIN & SHAREWARE.

Carefully selected and edited programs for I.B.M. Send S.A.S.E. for free catalog.

C.C.S., Inc. Dept. B1

P.O. Box 312, Lafayette Hill, PA 19444

Inquiry 671.

FREE CATALOG PUBLIC DOMAIN/SHAREWARE

• 400 IBM PC & compatibles disks •
• 200 Amiga disks • 125 Atari ST disks
PC disks as low as \$1.25 each, Amiga & ST as low as \$1.60 each! Rent or buy. Free shipping! Call toll free, write or circle reader service for FREE BIG CATALOG with full descriptions. Please specify computer—48 hr. turnaround!

Computer Solutions

P.O. Box 354—Dept. B, Mason, Michigan 48854
1-800-874-9375 (M-F 10-6 EST) 1-517-628-2943

Inquiry 672.

RENT SOFTWARE \$1/DISK

Rent Public Domain and User Supported Software for \$1 per diskfull or we'll copy. IBM (3½" also), Apple, C-64, Sanyo 550 and Mac. Sampler \$3. VISA/MC. 24 hr. info/order line. (619) 941-3244 or send #10 SASE (specify computer) Money Back Guarantee!

FutureSystems

Box 3040 (T), Vista, CA 92083

office: 10-6 PST Mon-Sat. (619) 941-9761

Inquiry 673.

THE BUYER'S MART

PUBLIC DOMAIN

FREE SOFTWARE

Buy or Rent \$1/disk

World's largest Free Software Library of IBM PC & Compatibles and Macintosh. Over 3000 programs for Religion, Utilities, Business, Com., Word Processor, Education, and Games on 5.4" and 3.5" format. Best quality, Lowest rate, and Fastest service. For fast free catalogue write to:

SOFTSHOPPE

P.O. Box 15022, Ann Arbor, MI 48106
(313) 763-8721

Inquiry 674.

FREE SOFTWARE

We send you 15-20 new IBM programs a month on 5 disks—FREE! You pay only \$5. shipping/handling. Annual membership reg. \$29.95. Join today for only \$9.95 and we'll send you over 30 programs on 10 disks as a bonus—FREE! No gimmicks—no catches!

toll free 800 669-2669 ext 348

SOFTWARE of the MONTH CLUB
we take visa/mastercard/amex

Inquiry 675.

SCANNING SERVICE

Signature Scanning Service

If you have a HP LaserJet Plus, Series II or compatible, have your signature made into a graphic macro. Save time! Save yourself from writer's cramp! Let your LaserJet sign those letters for you! Includes instructions for most popular word processors. One signature only \$50. Three or more, only \$40 each. Logos and letterheads also available from \$125. Send for free samples!

Orbit Enterprises, Inc.

P.O. Box 2875-BY, Glen Ellyn, IL 60137
(312) 469-3405

Inquiry 676.

SECURITY

TOTAL PRIVACY \$49

Powerful data protection for PC/AT—documents, databases, spreadsheets—any data. The Diary's DES and Ultra Fast encryption keep the curious out. Menu and command line modes. Comprehensive Help. Clear manual starts you quickly. \$49 introductory price. \$10 Demo. VISA/MC/COD. 90 day money back guarantee.

DIARY 1-800-87-DIARY

Toll Free Information 24 Hours a Day
Or write, P.O. Box 70443, Bellevue, WA 98007

Inquiry 677.

BIT-LOCK® SECURITY

Piracy SURVIVAL 5 YEARS proves effectiveness of powerful multilayered security. Rapid decryption algorithms. Reliable/small port transparent security device. PARALLEL or SERIAL port. Countdown and timeout options also available. KEY-LOK™ security at about 1/2 BIT-LOCK cost.

MICROCOMPUTER APPLICATIONS

3167 E. Otero Circle, Littleton, CO 80122
(303) 922-6410

Inquiry 678

COPY PROTECTION

The world's leading software manufacturers depend on Softguard copy protection systems. Your FREE DISKETTE introduces you to SuperLock™—invisible copy protection for IBM-PC (and compatibles) and Macintosh.

- Hard disk support
- Customized versions
- No source code changes
- LAN support
- New upgrades available

(408) 773-9680

SOFTGUARD SYSTEMS, INC.

710 Lakeway, Suite 200, Sunnyvale, CA 94086
FAX (408) 773-1405

Inquiry 679.

SOFTWARE/ACCOUNTING

BILLING+PAYROLL = \$199

ABP combines timekeeping, billing, and payroll function into one simple, easy to use software package. The user simply needs to enter timesheet information. Invoices and/or checks are then automatically available for printing directly off our system.

ASHLEY SOFTWARE

5010 North Bridges Drive, Alpharetta, GA 30201
(404) 475-2930

Inquiry 680.

dBASE BUSINESS TOOLS

- * General Ledger
- * Accounts Recvbl.
- * Order Entry
- * Sales Analysis
- * Purch Ord/Inventory
- * Accounts Payable
- * Job Costing
- * Job Estimating

\$99 EA. + s&h w/dBASE 2, 3 or 3+ SOURCE CODE

DATAMAR SYSTEMS™

4876-B Santa Monica Ave. Cr. Crd/Chk/COD
San Diego, CA 92107 (619) 223-3344

Inquiry 681.

SOFTWARE/BASIC

FREE CATALOG QUICK BASIC TOOLS

Why shop around for hard-to-find BASIC tools and utilities? Our FREE Catalog includes: FINALLY! Family of Products, Data Base, Graphics & Window Libraries, Screen Generators, and Utilities.

Call 1-800-423-3400

KOMPUTERWERK, INC.

851 Parkview Blvd., Pittsburgh, PA 15215

Inquiry 682.

SOFTWARE/BASIC TOOLS

QuickWindows

As seen in the Microsoft Value-Pack Catalog! Create windows, pop-up and pull-down menus, data-entry screens, and multiple-input dialog boxes quickly and easily. Full support of Microsoft mouse. Join the many Fortune 500 companies using QuickWindows and order your copy today. QuickWindows \$79. Advanced \$139. For Microsoft QuickBASIC or BASCOM. See pg.78, BYTE, March '88.

Software Interphase, Inc.

5 Bradley St., Suite 106 • Providence, RI 02908
(401) 274-5465 Call now for Free Demo Disk

Inquiry 683.

SOFTWARE/BUSINESS

DATA ENTRY SYSTEM

Heads-down data entry with two-pass verification for the PC/XT/AT - PS/2 & compatibles. Loaded with features like: Auto dup & skip, verify bypass, range checks, & table lookups. Fully menu driven only \$395. Call for free 30 day trial period.

COMPUTER KEYES

21929 Makah Rd., Woodway, WA 98020
(206) 776-6443 1-800-356-0203

Inquiry 684.

TSA88-TRANSPORTATION

A general-purpose system for solving transportation, assignment and shipment problems. Solves transportation problems with up to 510 origins and/or destinations by applying the Transportation Simplex Algorithm. Menu-driven with features similar to LP88. Requires 192K, \$149 with 8087 support user's guide. VISA/MC.

EASTERN SOFTWARE PRODUCTS, INC.

P.O. Box 15328, Alexandria, VA 22309
(703) 360-7600

Inquiry 684.

SOFTWARE/BUSINESS

dFELLER Inventory

Business inventory programs written in modifiable dBASE source code.

dFELLER Inventory \$150.00

Requires dBASE II or III, PC-DOS/CPM

dFELLER Plus \$200.00

with History and Purchase Orders

Requires dBASE III or dBASE III Plus (For Stockrooms)

Feller Associates

550 CR PPA, Route 3, Ishpeming, MI 49849
(906) 486-6024

Inquiry 685.

FINANCE MANAGER II

Easy to learn, fully integrated, menu-driven book-keeping system for small business and personal use. IBM PC, XT, AT, PS/2 or compatible. Try before you buy! General Ledger evaluation copy for only \$10!

CALL TODAY! (719) 528-8989

HOOPER INTERNATIONAL: PO Box 62219,
Colorado Springs, Colorado 80962

Inquiry 686.

1-2-3® + @RISK = Risk Analysis

Manage risk with @RISK 1-2-3 Add-In! An @RISK simulation automatically reflects thousands of "what-if" scenarios. View full range of possible outcomes. Monte Carlo simulation. Graphs in .PIC format. 30 new probability distribution @functions Now required for all Harvard MBAs. FREE DEMO

Palisade Corporation

2189 Elmira Road, Newfield, NY 14867
(607) 564-9993

Inquiry 687.

"HANDWRITING" BY COMPUTER

Now Trash-proof your mailings!

Unique new program "writes" letters and addresses envelopes in script. Many handwriting styles available including ordinary, calligraphy and even Thomas Jefferson! For IBM PC/XT/AT, compatibles and 24-pin dot matrix or HP laser printers.

Introductory Christmas card Special \$89

PC SOFTWARE SERVICES, INC.

16405 Bridge End Rd., Suite 102, Miami Lakes, FL 33014
(305) 362-9277

Inquiry 688.

SOFTWARE/CHURCH

PowerChurch Plus®

Fast, friendly, reliable church administration system. Full fund accounting, mailing lists, membership, contributions, attendance, word processing, accts. payable, payroll, multi-user support, and much more - all for \$695 complete. FREE demo version.

F1 SOFTWARE

P.O. Box 3096, Beverly Hills, CA 90212
(213) 854-0865

Inquiry 689.

ROMAR CHURCH SYSTEMS™

Membership-61 fields plus alternate addresses; labels, letters, reports any field(s). Offering-256 funds; optional pledge; statements; post to 255/yr. Finance-gen. ledger w/budget; up to 500 subtotals & 99 depts., month & YTD reports anytime for any month. Attendance-8 service times, 250 events per service; 60 consecutive weeks. Available for floppy, 3½ & hard disk. Ad too short! Write for free 48-page guide.

Romar Church Systems, Attn: BJB

P.O. Box 4211, Elkhart, IN 46514

(219) 262-2188

Inquiry 690.

THE BUYER'S MART

SOFTWARE/EDUCATION

FOREIGN LANGUAGES

Set 1: Spanish-English/English-Spanish \$49.95 (USA)
Set 2: Swedish-English/English-Swedish \$49.94 (USA)
Each set has: Translation dictionaries (20,000 words) to look up words instantly, find synonyms, add/delete words, and translate text files. Self-teaching, fill-in, multiple choice testing, errors recorded in dictionary, menu driven, a great learning aid. IBM comp. 128K, DOS 2.0, each set includes 3 DSDD disks.

WORLDWIDE-WORDS SOFTWARE
1260 Acropolis Dr., Lafayette, CO 80026, (303) 650-8818

Inquiry 691.

SOFTWARE/ENGINEERING

PRACTICAL ENGINEERING TOOLS Hobbyists—Students—Engineers

CIRCUIT DESIGN...CompDes, menu selections from basic electricity through circuit designs.
MATHEMATICS...CompMath, menu selections from general math through statistics.
ANALYSIS...CompView, Fourier Analysis of waveforms and filters. PC/MSDOS. \$49 each, VISA/MC

BSOFT SOFTWARE (614) 491-0832
444 Colton Rd., Columbus, OH 43207

Inquiry 692.

Affordable Engineering Software

FREE APPLICATION GUIDE & CATALOG
Circuit Analysis • Root Locus • Thermal Analysis • Plotter Drivers • Engineering Graphics • Signal Processing • Active/Passive Filter Design • Transfer Function/FFT Analysis • Logic Simulation • Microstrip Design • PC/MSDOS • Macintosh • VISA/MC

BV Engineering • Professional Software
2023 Chicago Ave., Suite B-13, Riverside, CA 92507
(714) 781-0252

Inquiry 693.

VERSATILE DSP & DISPLAY

PC DATA MASTER is a DOS shell which integrates a full set of signal processing functions: flexible graphics, data file math, DSP utilities, data sampling/generation, and interactive help. Support for CGA, EGA, VGA, Herc & AT&T. Add custom analysis or graphics functions easily using your favorite compiler. \$135. Toolkit \$45. Demo \$10.

Durham Technical Images
P.O. Box 72, Durham, New Hampshire 03824-0072
(603) 868-5774

Inquiry 694.

Engineer's Aide

Join the Desktop Engineering Revolution!

- Pipeline/Ductwork Sizing
- Orifice/Control Valve Sizing
- Pump/Fan/Compr. Sizing
- Project Financial Analysis
- Heat Exchanger Sizing
- Conversion Calculator
- Fluid Properties Library
- Specification Writer

Above programs in one stand alone integrated package for \$695. For IBM PC & Macintosh.

EPCON
1-800-367-3585 P.O. Box 270, Woodsfield, OH 43793

Inquiry 695.

• COMPOSITE ANALYSIS •

Menu driven program for analyzing composite laminates.

- Calculates fiber stresses & strains
- Graphical strength ratios
- Database includes Graphite, Kevlar & Fiberglass
- SI/US units; thermal & moisture effects

Send check/MO for \$225 or \$3 for demo disk to:

GS composites

7627 E.37th N. #706, Wichita, KS 67226

Inquiry 696.

434 B Y T E • NOVEMBER 1988

SOFTWARE/ENGINEERING

SOURCE CODE SOFTWARE

Mechanical, Civil, Electrical, Aerospace Engineering
All programs supplied with sourcecode in BASIC, C or FORTRAN. Written by professionals and educators from leading industries and universities. Educational discounts available. Send for Free catalog.

Kern International, Inc.
100 Weymouth St., Dept. B1, Rockland, MA 02370
(617) 871-9892

Inquiry 697.

TRICALC

Three Engineering Calculators in one MS.DOS software
Includes: 1) Full function Scientific calculator. 2) STAT Calculator with link to Lotus. Generate custom reports. 3) 512 step Programmable Calculator. 128 variables. Print the program and answers. Auto input error checking and context sensitive help. \$49.95.

14 day money-back guarantee if not delighted
MCAE Technologies, Inc.
3474 Nova Scotia Ave., San Jose, CA 95124
(408) 371-6095

Inquiry 698.

SIMULATION WITH GPSS/PC™

GPSS/PC™ is an IBM personal computer implementation of the popular mainframe simulation language GPSS. Graphics, animation and an extremely interactive environment allow a totally new view of your simulations. Simulate complex real-world systems with the most interactive and visual yet economical simulation software.

MINUTEMAN Software
P.O. Box 171/Y, Stow, Massachusetts, U.S.A.
(508) 897-5662 ext. 540 (800) 223-1430 ext. 540

Inquiry 699.

Circuit Analysis — SPICE

Non-linear DC & Transient; Linear AC.
* Version 3B1 with BSIM, GaAs, JFET, MOSFET, BJT, diode, etc. models, screen graphics, improved speed and convergence.
* PC Version 2G6 available at \$95.
Call, write, or check inquiry # for more info.

Northern Valley Software
28327 Rothrock Dr., Rancho Palos Verdes, CA 90274
(213) 541-3677

Inquiry 700.

FREE ENGINEERING MAGAZINE

Personal Engineering is a monthly magazine sent free of charge (USA only) to scientists/engineers who use PCs for technical applications. Topics each month include **Instrumentation • Data Acq/Control • Design Automation**. To receive a free sample issue and qualification form either circle below or send request on letterhead to:

Personal Engineering Communications
Box 1B21, Brookline, MA 02146

Inquiry 701.

EC-Ace ANALOG CIRCUIT ANALYSIS

You can afford to get started with EC-Ace, a subset of the powerful ECA-2 circuit simulator. Includes all the basics and built-in graphics.

- AC, DC, Temperature, Transient
- A full 525 pg. ECA-2 manual.
- Interactive, twice as fast as SPICE.

EC-Ace 2.31 IBM PC or Mac \$145.
Call 313-663-8810 for FREE DEMO
Tatum Labs, Inc.
1478 Mark Twain Ct., Ann Arbor, MI 48103

Inquiry 702.

SOFTWARE/FINANCIAL

"THE FINANCIAL PLANNER" SOFTWARE

SAVE 40% Retail \$99.95 -OUR PRICE \$59.95 (+ 2.00 SH)
PA residents add 6% tx. Menu Driven program w/print Manual

- Balance Checkbook
- Prepare Budgets
- Prepare Financial Statements
- Loan Amortization Schedule
- Manage Investments
- Plan Savings & more

Specify Apple Iic, Iic, Iiigs, IBM PC or Compatible.
CKS/MC/VISA SHIPPED UPS

SOFTECH INDUSTRIES, INC. 717-584-5191
RD 1, Bx 117A, Dept B901, Hughesville, PA 17737

Inquiry 703.

SOFTWARE/FORECAST

FORECAST PRO

An excellent forecasting package that uses *artificial intelligence* to help both the beginner and the experienced forecaster achieve top-notch results. Time series analysis techniques include exponential smoothing, Box-Jenkins, & dynamic regression.

CALL NOW FOR A FREE DEMO DISK!

Business Forecast Systems, Inc.
68 Leonard Street, Belmont, MA 02178
(617) 484-5050 TELEX #710-3201382

Inquiry 704.

SOFTWARE/GEOLOGICAL

GEOLOGICAL CATALOG

Geological software for log plotting, gridding/contouring, hydrology, digitizing, 3-D solid modelling, synthetic seismogram, fracture analysis, image processing, scout ticket manager, over 50 programs in catalog. Macintosh too! Please call, or write, for Free Catalog!

RockWare, Inc.
4251 Kipling St., Suite 595, Wheat Ridge, CO 80033 USA
(303) 423-5645

Inquiry 705.

SOFTWARE/GRAPHICS

TurboGeometry Library

Over 150 2&3 dimensional routines, includes Intersections, Transformations, Equations, HiddenLines, Perspective, Curves, Areas, Volumes, Clipping, Planes, Vectors, Distance, Polydecomp, IBM PC and Comp. MAC. MS-DOS 2+. Turbo Pascal, Turbo C, MSC & Turbo Pascal MAC. 400 pg. manual, source code. \$149.95 + 5.00 S&H. VISA, MC, Chk, PO. 30 Day guarantee.

Disk Software, Inc.
2116 E. Arapaho #487, Richardson, TX 75081
(214) 423-7288

Inquiry 706.

SEGS

SCIENTIFIC & ENGINEERING GRAPHICS SYSTEM

See "What's New" pg 82, BYTE June, 1988
Log, Data & Linear Axes; Curve Fitting & Smoothing 1-2-3 Interface; Numeric Spreadsheet. Supports all Video Standards, PC Printers & Plotters. 10 Curves w/5000 points each. Plus much more. Call Today.

Edmond Software
3817 Windover Drive 1-405-842-0058
Edmond, Oklahoma 73013 1-800-992-3425

Inquiry 706.

FPLOT PEN PLOTTER EMULATOR

Use your dot matrix or laser printer as an HP pen plotter. Fast hi-res output. Vary line width. Includes VPLOT virtual plotter utility to capture plotting commands. Supports NEC P5/P6, IBM Proprinter, Epson LQ/MX/FX, HP LaserJet. Uses Hercules, CGA, EGA or VGA for screen preview. \$64 check or m.o.

FPLOT CORPORATION
Suite 605, 24-16 Steinway St., Astoria, NY 11103
212-418-8469

Inquiry 707.

THE BUYER'S MART

SOFTWARE/SCIENTIFIC

Scientific/Engineering/Graphics Libraries

Turbo Pascal, Turbo C, Microsoft C
Send for FREE catalogue of software tools for Scientists and Engineers. Includes: Scientific subroutine libraries, device independent graphics libraries (including EGA, HP plotter and Laserjet support), scientific charting libraries, 3-D plotting library, data acquisition libraries, menu-driven process control software. Versions available for a variety of popular languages.

Quinn-Curtis

1191 Chestnut St., Unit 2-5, Newton, MA 02164
(617) 965-5660

Inquiry 726.

Scientific Software

Scientific CALCULATOR parallel processing & graphics, Sci.NOTEPAD free-form data management, DIALSEARCH literature searches, SCI.GRAPHPAD and SCI.STATPAD graphics-aided data analysis (log/semilog plots, error bars, curve fit, more). From \$85-On 5 1/4 and 3 1/2" MS-DOS disks. 30 day \$ back. VISA/MC/PO. Also see our ad under LANGUAGES.

Scientific LOGICS Inc.

21910 Alcazar Ave., Cupertino, CA 95014
(408) 446-3575 Compuserv 74017,663

Inquiry 727.

SOFTWARE/SECURITY

KEEP YOUR PC PRIVATE!

MicroLock PC Security Software protects MS-DOS files and programs from unauthorized access. MicroLock features unlimited passwords, Quick Encryption, Locks Directories, Hides files, Locks .EXE and .COM files, uses one simple control menu w/on-screen help!

Only \$89.95! (+\$3 s/h) 30 DAY MONEY BACK GUARANTEE
Check/Visa/MC

MicroNiche, Inc.

The Summit, Suite 110, 4350 Brownsboro Rd.
Louisville, KY 40207

Orders: (502) 893-4526 FAX: (502) 893-4503

Inquiry 728.

HANDS OFF THE PROGRAM®

- Locks Hard Disk - Restricts Floppy Use.
- Protects Subdirectories.
- Normal Use of DOS Commands and Application Software.
- IBM PC, XT, AT and True Compatibles.
- DOS V2.0 and Higher. Hard Disk System.
- Keep Other People's HANDS OFF Your System

- \$89.95 VISA/MC

SYSTEM CONSULTING, INC.

314 Canterbury Dr., Pittsburgh, PA 15238

(412) 963-1624

Inquiry 729.

SOFTWARE/SORT

OPT-TECH SORT/MERGE

Extremely fast Sort/Merge/Select utility. Run as an MS-DOS command or CALL as a subroutine. Supports most languages and filetypes including Btrieve and dBASE. Unlimited file sizes, multiple keys and much more! MS-DOS \$149. XENIX \$249.

(702) 588-3737

Opt-Tech Data Processing

P.O. Box 678 - Zephyr Cove, NV 89448

Inquiry 730.

SOFTWARE/TAX PREP

W-2 & 1099 ON FLOPPY

The MAG COLLECTION of programs make an IRS/SSA FORMAT floppy from a data entry screen or imported ASCII file. Includes manual and application forms.

- Used nation wide
- Menus, user friendly
- Step-by-step data entry
- Prints W-2 & 1099
- Free phone support
- PC compatible

Illinois Business Machines Inc.

Department MAG
1403 Box 310 Troy Rd., Edwardsville, IL 62025
PH. # (618) 692-8060

Inquiry 731.

436 B Y T E • NOVEMBER 1988

SOFTWARE/TOOLS

NATURAL LANGUAGE SOFTWARE

Use JAKE to create a front end to your database, game, or graphics program! JAKE translates English queries and commands into C function calls and data structures. JAKE offers context-sensitive semantic processing; interfaces easily; <64K mem.

\$495. INTERACTIVE DEMO \$10

ENGLISH KNOWLEDGE SYSTEMS, INC.

5525 Scotts Valley Dr. #22, Scotts Valley, CA 95066
(408) 438-6922

Inquiry 732.

STATISTICS

STATA

Statistics and graphics join to make STATA the most powerful package for the PC. No comparable program is as fast, friendly, and accurate. \$20 Demo. Quantity discount available. Call toll-free for more information. AX/VISA/MC.

1-800-STATAPC

Computing Resource Center

10801 National Boulevard, Los Angeles, CA 90064
(213) 470-4341

Inquiry 733.

THE SURVEY SYSTEM

An easy-to-use package designed specifically for questionnaire data. Produces banner format, cross tabs & related tables, statistics (incl. regression) & bar charts. Codes and reports answers to open-end questions. All reports are camera-ready for professional presentations. CRT interviewing option.

CREATIVE RESEARCH SYSTEMS

15 Lone Oak Ctr., Dept. B, Petaluma, CA 94952

707-765-1001

Inquiry 734.

STATPlan III

Easiest to use statistics program available. Complete range of statistics: curve fitting, crosstabs, correlation, multiple regression, t-tests, time-series analysis, etc. Graphics with printer/plotter output. Capable of handling up to 50,000 data points. Interfaces with Lotus files. Demo disk available. \$179.

The Futures Group

76 Eastern Blvd., Glastonbury, CT 06033
203/633-3501

Inquiry 734.

STATISTICS CATALOG!

If you need statistics for IBM PC or Apple II, call us and let our technical advisors help you find the statistics programs you need. Write or call now to get a FREE catalog of statistics and quality control software.

HUMAN SYSTEMS DYNAMICS

9010 Reseda Blvd., Ste. 222
Northridge, CA 91324

(800) 451-3030 (818) 993-8536 (CA)

Inquiry 735.

RESULTS NOT SIGNIFICANT?

Next time use EX-SAMPLE. Expert program estimates sample size using power analysis for comparisons of means, props, regression, ANOVA, chi-square, log-linear, LISREL, surveys, experiments, many more. Justify sample size to funding agencies, plan sampling budget. Can pay for itself in a single study. IBM/MS-DOS, \$195+s/h. (50% educ. disc.). VISA/MC/AMEX/PO, 30-day guarantee. Call now for FREE brochure.

The Idea Works, Inc.

100 West Briarwood, Columbia, MO 65203

1-800-537-4866

314-445-4554

Inquiry 736.

STATISTICS

NCSS

Professional, easy to use, menu driven statistical system. Used by over 5,000 researchers.

- 5.0 Statistical System—\$99
- 5.1 Graphics (2D & 3D)—\$59
- 5.3 Power Pac Supplement—\$49
- 5.4 Exp. Design/QC—\$49
- 5.5 Survival Analysis—\$59

We accept checks, PO's, Visa, MC. Add \$3 s/h.

NCSS-B

865 East 400 North, Kaysville, UT 84037
801-546-0445

Inquiry 737.

STATISTIX™ II

Comprehensive, powerful and incredibly easy-to-use. Full screen editor, transformations, linear models (ANOVA, regression, logit, PCA, etc), ARIMA, most standard stat procedures. Clear, well organized documentation. Satisfaction guaranteed. \$169 PC DOS, \$99 Apple II.

NH ANALYTICAL SOFTWARE

P.O. Box 13204, Roseville, MN 55113
(612) 631-2852

Inquiry 738.

EcStatic

\$49.95

A full featured statistical package that's powerful, convenient, astonishingly easy to use and extraordinarily inexpensive. At last! A statistical package that gives you the tools you need, the clarity you want and at a price you can afford. Ideal for researchers, professionals, and students. Volume discounts available. To order call or write to:

SomeWare In Vermont, Inc.

P.O. Box 215, Montpelier, VT 05602

1-800-451-4580 (496-3173 in Vermont)

Inquiry 739.

Spreadsheet Statistics

NEW! 23 comprehensive statistics and forecasting modules for analyzing LOTUS worksheets. Low cost \$24.95 each. Easy to use. Includes tutorial. Basic and advanced statistics with graphics and many user-definable options. Compare. Free brochure.

Walonick Associates, Inc.

6500 Nicollet Ave. S., Minneapolis, MN 55423

(612) 866-9022

Inquiry 740.

UTILITIES

BASIC FORMAT UTILITY +

FORMATS SOURCE CODE WITH BOLD VARIABLES, OR KEYWORDS, UNDERLINED LOOPS, OTHER OPTIONS. CROSS REFERENCE VARIABLES, CALLS, AND REDIRECTS. FAST ON SCREEN VARIABLE TRACE. NUMBER/UN-NUMBER UTILITY AIDS PROGRAM DEVELOPMENT FOR LATEST BASICS. \$25.00 (DOS 2+) MONEY BACK GUARANTEE

AVID COMPUTING

1012 MORSE AVE, #11, SUNNYVALE, CA 94086

(408) 747-0244

Inquiry 741.

Enhanced DOS Commands

Get directory listings of all files that don't match a template. Search all directories for files matching a template. New commands and new versions of existing commands, all with lots of variable options. Plus all commands accept special codes to reduce repetitive entries. Get the most from DOS with these time-saving routines. For MS-DOS/PCDOS 2.0 and higher. \$29.95

Driscoll Graphics

135 E. Church, P.O. Box 625, Clinton, MI 49236

Inquiry 742.

THE BUYER'S MART

UTILITIES

MATCH PRINTERS TO PC

For less than \$30 **MatchFont** and **Match-a-Printer** are great for foreign and scientific writings. Get all the characters you need from most programs and printers (Apple & Epson printers, daisywheels, etc.), Greek, French, Italian, Spanish, German, Swedish, Japanese, graphics... You name it! To receive a **FREE** demo disk use the inquiry # below or write to:

MATCH SOFTWARE

6426 Coldwater Canyon, North Hollywood, CA 91606-1113

Inquiry 743.

UTILITIES

LOGGER®

Logger, for IBM-PC and compatibles, tracks and reports: User, Time on, Time off, Directories used, Programs used, Program start/end time, and calculates totals. Tracks directories/files: Opened, Created, Renamed, Deleted. Completely transparent. **Retails for \$74.95** with quantity discounts available.

System Automation Software, Inc.

8555 16th St., Silver Spring, MD 20910
1-800-321-3267 or 1-301-565-8080

Inquiry 746.

WORD PROCESSING

FARSI / GREEK / ARABIC / RUSSIAN

Hebrew, all European, Scandinavian, plus either Hindi, Punjabi, Bengali, Gujarati, Tamil, Thai, Korean, Viet, or IPA. Full-featured multi-language word processor supports on-screen foreign characters and NLC printing with no hardware modifications. Includes Font Editor, \$355 dot matrix; \$150 add'l for laser; \$19 demo. S/H in U.S. incl'd. Req. PC, 640K, graphics. 30 day Guarantee. MC/VISA/AMEX

GAMMA PRODUCTIONS, INC.

710 Wilshire Blvd., Suite 609, Santa Monica, CA 90401
213/394-8622 Tlx: 5106008273 Gamma Pro SNM

Inquiry 749.

ATTENTION FORMAT VICTIMS!!!

REARGUARD password protects you from accidental formatting of your hard disk. **Not** memory resident **nor** modifies DOS. Completely **automated** installation. Manual and diskette provided.

ONLY \$29.00 + \$4.00 S/H VISA/M-C/COD UPS B/R

MICROBRIDGE COMPUTERS

655 Sky Way #125, San Carlos, CA 94070
Order toll free 1-800-523-8777

415-593-8777 (CA) 212-334-1858 (NY)
TELEX EZLINK 62873089 FAX 415-593-7675

Inquiry 744.

FastRetrieve®

FastRetrieve, for IBM-PC and compatibles, indexes your wordprocessing documents to instantly (< 1 sec.) retrieve text using your search expressions (boolean statements, phrases, spelling variations). Retrieved text can be edited, printed, and saved to disk. **Retails for \$99**. Discounts available.

System Automation Software, Inc.

8555 16th St., Silver Spring, MD 20910
1-800-321-3267 or 1-301-565-8080

Inquiry 747.

CARLOS?

It's a memory resident spelling checker and hyphenation utility to be used in addition to DisplayWrite, WordPerfect, MS Word, Xywrite, Nota Bene etc. Basing on real dictionaries it can be used to check as you type (on-line) and for spelling verification in documents. No line adjustment required. It fills in all possible (correct) hyphens. German development on high level quality. Dictionaries for German and US-English available. Additional languages possible. **International distributors:** Please contact

text & satz Datentechnik

Oldenburgeralle 62, D-1000 Berlin 19

Inquiry 750.

The NOVA UTILITIES

Twelve advanced DOS programs that are on every user's wish list. Disk editor, file recovery, point-and-shoot window directory manager, encrypt and compress files, DOS command line qualifiers, find, view, delete, move, copy, more! **Less than \$6 per program** at only **\$69.95** complete with 100+ page manual.

NOVA SOFTWARE, Inc.

P.O. Box 37464, Albuquerque, NM 87176 (505) 836-8400

Inquiry 745.

\$79.95!!

Order the **RED Utilities** now! Programs include: Disk cache speeds hard and floppy disks. Printer spooler. Batch file compiler speeds batch files. Path command for data files. Wild card exceptions. Sort directories. Over 10 more programs. IBM PC. Visa/MC. Send for free catalog.

The Wenham Software Company

5 Burley St., Wenham, MA 01984 (508) 774-7036

Inquiry 748.

PC-Write 3.0 — Shareware

Fast, full featured word processor for IBM PC. Now edits large files & multiple columns. Also spell check, mailmerge, networking, ASCII, and macros. Easy to use—optional menus. Supports 500 printers incl. lasers. Software, guide and tutorial on disk: \$16. Registration with manual, telesupport, newsletter and 2 updates: \$89.

90 day money back guarantee. VISA/MC.

Quicksoft

1-800-888-8088

219 First Ave. N., #224-BYTC, Seattle, WA 98109

Inquiry 396.

Recover deleted files fast!

Disk Explorer now includes automatic file recovery. You type in the deleted file's name, Disk Explorer finds and restores it. Disk Explorer also shows what's really on disk; view, change or create formats, change a file's status, change data in any sector. MS-DOS \$75 U.S. Check/Credit card welcome.

QUAID SOFTWARE LIMITED

45 Charles St. E. 3rd Fl.
Toronto, Ontario, Canada M4Y 1S2
(416) 961-8243

Advertise your computer products in
THE BUYER'S MART.

It's easy to get your sales message into print. Just send us typewritten copy or phone in your ad. And as a unique feature, every **BUYER'S MART** ad is assigned a reader service number which will provide your company with valuable inquiries.
Call Mark Stone for more information at 603-924-3754

BYTE/McGraw-Hill
One Phoenix Mill Lane
Peterborough, NH 03458

See our 16 page, four-color insert on pages 255-270
with New Products, Computer Peripherals and Much More!

COMPUTER PRODUCTS

Jameco IBM AT Compatible 16MHz 80286 NEAT Motherboard

- Expandable to 8MB RAM (Zero-K included)
- 8/12 or 8/16MHz switchable • Supports all NEAT functions including shadow RAM, EMS 4.0, RAM re-mapping and selectable wait states • 80287-10 Coprocessor capability
- Norton SI rating of 15.6
- AMI BIOS ROMs included
- One-year warranty



JE3010 8/12/16MHz NEAT (AT) . . \$499.95

— Additional Motherboards —

JE1001 4.77/8MHz (PC/XT) . . . \$ 89.95
JE1002 4.77/10MHz (PC/XT) . . . \$109.95
JE3005 8/12MHz (AT) \$329.95

Jameco IBM PC/XT/AT Compatible Keyboards



JE1016 Pictured

JE1015 Standard AT layout (XT/AT) . . \$59.95
JE1016 Enhanced layout (XT/AT) . . \$69.95

TEST EQUIPMENT

Metex M4650:

- Handheld, high accuracy
- 4 1/2 Digit LCD
- Manual ranging with Overload Protection
- Audible continuity tester
- Tests: AC/DC Voltage, Resistance, Continuity, Capacitance, Frequency
- One Year Warranty
- Size: 7"L x 3.5"W x 1.5"H



M4650 . . . \$99.95

JAMECO SOLDERLESS BREADBOARD SOCKETS

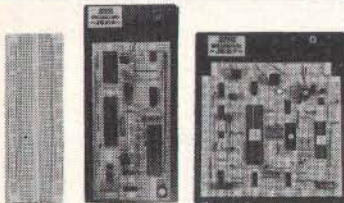

Part No.	Dim. L" x W"	Contact Points	Binding Posts	Price
JE20	6 1/2 x 3/4	200	0	\$ 2.95
JE21	3 1/4 x 2 1/4	400	0	\$ 4.95
JE22	6 1/2 x 1 1/4	630	0	\$ 5.95
JE23	6 1/2 x 2 1/4	830	0	\$ 7.95
JE24	6 1/2 x 3 1/4	1,360	2	\$14.95
JE25	6 1/2 x 4 1/4	1,660	3	\$22.95
JE26	6 1/2 x 5 1/4	2,390	4	\$27.95
JE27	7 1/4 x 7 1/2	3,220	4	\$37.95

DATA BOOKS

400041 NSC Linear Data Book-Vol. I (88) . . . \$14.95
400042 NSC Linear Data Book-Vol. II (88) . . . \$ 9.95
400043 NSC Linear Data Book-Vol. III (88) . . . \$ 9.95
210830 Intel Memory Handbook (88) \$17.95
230843 Intel Microsystem Hndbk. Set (88) . . . \$24.95

Jameco IBM PC/XT 8MHz Turbo Compatible Kit With 256K RAM

- Free! QAPLUS Diagnostic Software Included!
- Free! PC Write Word Processing Software Included!
- 256K RAM Included, Expandable to 640K
- 4.77 or 8MHz Switchable
- AMI BIOS ROM Included
- Save \$128.06



Build Your Own And LEARN!

Part No.	Description	Price
JE1001	4.77/8MHz Turbo Motherboard.	\$89.95
	(Zero-K RAM — includes AMI BIOS ROM)	
JE1010	Flip-Top Case.	34.95
JE1015	XT/AT Compatible Keyboard.	59.95
JE1020	5.25" DSDD Disk Drive (Black Bezel).	89.95
JE1030	150 Watt Power Supply.	59.95
JE1040	360K Floppy Controller.	29.95
JE1050	Mono/Graphics Card with Printer Port.	59.95
AMBER	12" Monochrome Amber Monitor.	99.95
41256-150	256K RAM (9 chips).	103.41

Save \$128.06 Regular List \$628.01
JE3002 IBM Compatible PC/XT 8MHz Turbo Kit. . . \$499.95

IBM COMPATIBLE DISPLAY MONITORS

12" Amber Monochrome — TTL Input, High Resolution (PC/XT/AT) AMBER.	\$99.95
14" RGB Color — CGA Compat. Amber/Green/Color Switchable, 640 x 200 Resolution (PC/XT/AT) CTX2410.	\$279.95
14" EGA Color — EGA/CGA Compatible, 720 x 350 Max. Resolution (PC/XT/AT) TM5154.	\$399.95

14" EGA Monitor and EGA Card — EGA compatible, 720 x 350 Max. Resolution — displays up to 16 colors (PC/XT/AT) JE1059 SAVE \$40.00!	\$519.95
14" Multiscan Color—VGA/PGC/EGA compat., 800 x 600 Max. Res. (PC/XT/AT) TM5155.	\$549.95

JAMECO IBM PC/XT/AT COMPATIBLE CARDS

Graphic Display Cards MGA, CGA or EGA! JE1050	
JE1050 Mono Graphics Card w/Printer Port (PC/XT/AT).	\$59.95
JE1052 Color Graphics Card w/Printer Port (PC/XT/AT).	\$49.95
JE1055 EGA Card with 256K Video RAM (PC/XT/AT).	\$159.95
JE1071 Multi I/O with Drive Controller and Mono Graphics (PC/XT).	\$119.95

Multifunction, I/O and Expansion Cards

JE1060 I/O Card with Serial, Game, Parallel Printer Port and Real Time Clock (PC/XT).	\$59.95
JE1061 RS232 Serial Half Card (PC/XT)	\$29.95
JE1062 RS232 Serial Half Card (AT).	\$34.95
JE1065 I/O Card w/Serial, Game & Parallel Printer Port (AT).	\$59.95
JE1081 2MB of expanded or extended memory (zero-K on-board) (AT).	\$119.95
JE1082 3MB of expanded or extended memory, parallel printer port, serial port and game port (zero-K on-board) (AT).	\$169.95

Floppy and Hard Disk Controller Cards

JE1041 20/40MB Hard Disk Controller Card (PC/XT).	\$79.95
JE1043 360K/720K/1.2MB/1.44MB Floppy Disk Cont. (PC/XT/AT) \$49.95	
JE1044 360K Floppy/Hard Disk Controller Card (PC/XT).	\$129.95
JE1045 360K/720K/1.2MB/1.44MB Floppy/Hard Disk Controller Card (AT).	\$149.95

COMPUTER PERIPHERALS

AMI 80386 Motherboards

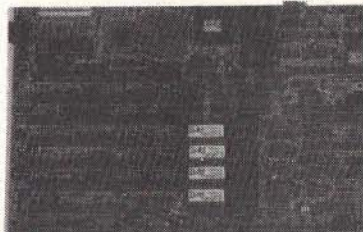

- Expandable to 2MB (Zero-K incl.) of 32-bit RAM with expansion board (included) • Expand an additional 8MB using the JE3030 (below, Zero-K incl.)
- XT footprint-AT compatible • 80387-16/20 capability • Built-in set-up and diagnostics • Includes AMI BIOS ROMs • One-year warranty

JE3020 16MHz 80386 (AT) . . . \$1399.95
JE3025 20MHz 80386 (AT) . . . \$1699.95
JE3030 8MB (Zero-K) Daughterboard . . \$299.95

Seagate 20,30 40 and 60MB Half Height Hard Disk Drives



ST225	20MB Drive only (PC/XT/AT)	\$224.95
ST225XT	20MB w/Controller (PC/XT)	\$269.95
ST225AT	20MB w/Controller (AT)	\$339.95
ST238	30MB Drive only (PC/XT/AT)	\$249.95
ST238AT	30MB w/Controller (PC/XT)	\$299.95
ST238XT	30MB w/Controller (AT)	\$389.95
ST251	40MB Drive only (PC/XT/AT)	\$429.95
ST251XT	40MB w/Cont. Card (PC/XT)	\$469.95
ST251AT	40MB w/Controller Card (AT)	\$539.95
ST251-1	40MB Fast 28ms (Drive only)	\$489.95
ST277	60MB Drive only (PC/XT/AT)	\$499.95
ST277XT	60MB w/Controller (PC/XT)	\$549.95
ST277AT	60MB w/Controller Card (AT)	\$639.95

40MB Tape Back-Up for IBM PC/XT/AT
DJ10 40MB Back-Up and Tape . . . \$349.95
TB40 40MB Tape Cartridge \$24.95

Jameco 5.25" PC/XT & AT Compatible Disk Drives

JE1022 (Pictured)

JE1020 360K Black Bzl. (PC/XT/AT) . . . \$ 89.95
JE1021 360K Beige Bzl. (PC/XT/AT) . . . \$ 89.95
JE1022 1.2MB Beige Bzl. (PC/XT/AT) . . \$109.95

3.5" PC/XT/AT Compatible Disk Drives

3.5" 720KB (Mounting Frame Included)
MF353B (PC/XT/AT) \$129.95 \$109.95
3.5" 1.44MB (Mounting Frame Included)
MF355B (PC/XT/AT) \$149.95 \$129.95

Datronics 2400/1200/300 Modems

NEW, Pocket Version!	
• Hayes command compatible • Bell 103/212A compatible • Auto-dial/auto-answer • FCC approved • 1-year warranty • Includes MaxiMite Communication Software (except 1200P)	
1200P 1200/300 Baud Pocket Modem.	\$ 99.95
1200H 1200/300 Baud Internal Modem.	\$ 69.95
2400S 2400/1200/300 Internal Modem.	\$129.95
1200C 1200/300 Baud External Modem.	\$ 99.95
2400E 2400/1200/300 External Modem	\$169.95

Data Sheets — 50¢ each
Prices Subject to Change

Send \$2.00 Postage for a
FREE 1989 CATALOG

FAX Numbers: 415-592-2503
or 415-595-2664

Telex: 176043

U.S. Funds Only

Shipping: Add 5% plus \$1.50 Insurance
(May vary according to weight)

California Residents:
Add 6%, 6 1/2% or 7%
Sales Tax

© 1988 Jameco Electronics 11/88



\$20 Minimum Order
IBM is a registered trademark of International Business Machines

Mail Order Electronics • Worldwide
Jameco
ELECTRONICS



1355 Shoreway Road, Belmont, California 94002

24 HOUR ORDER HOTLINE (415) 592-8097 • The Following Phone Lines Are Available From 7AM-5PM P.S.T.:

• Customer Service (415) 592-8121 • Technical Assistance (415) 592-9990 • Credit Department (415) 592-9983 • All Other Inquiries (415) 592-7108

NEW

MULTI-CHANNEL PS/2



COMMUNICATION BOARD

- Four Independent RS-232 Ports
- Flexible Interrupt/Address Options
- Discounts Available
- For Models 50, 60, 80

1-800-553-1170



478 E. Exchange St., Akron, OH 44304
 TEL: (216) 434-3154 FAX: (216) 434-1409
 TLX: 5101012726

Circle 266 on Reader Service Card

MULTI-CHANNEL RS-232



COMMUNICATION BOARD

- Eight Independent RS-232 Ports
- Flexible Interrupt/Address Options
- Comdriver Plus Software Included
- Discounts Available

1-800-553-1170



478 E. Exchange St., Akron, OH 44304
 TEL: (216) 434-3154 FAX: (216) 434-1409
 TLX: 5101012726

Circle 267 on Reader Service Card

FRAME GRABBERS

MODEL	RESOLUTION	PRICE with frame grab	PRICE without frame grab
HRT 256-4	256 x 256 x 4	495	NA
HRT 256-8	256 x 256 x 8	795	NA
HRT 512-8	512 x 512 x 8	995	NA
HRT 512-24	512 x 512 x 24	1995	1495

- CALL FOR DIFFERENT MODELS
- IBM PC/XT/AT COMPATIBLE
- DIGITALIZE IN REAL TIME
- COMPOSITE VIDEO IN
- 24 BIT RGB OUT except model HRT 256-4
- 16 level gray scale out
- SOFTWARE LIBRARY OF IMAGE ANALYSIS ROUTINES
- FREE SOFTWARE UPGRADES TO REGISTERED OWNERS
- FULL CREDIT ON UPGRADE PURCHASE IN FIRST YEAR
- RETURN OLD BOARD AND JUST PAY DIFFERENCE

INPUT DEVICES (optional)

Microsoft Mouse (bus or serial) \$99
 Bit Pad Plus by Summagraphics \$359



HRT

HIGH RES TECHNOLOGIES
 P.O. BOX 76
 LEWISTON, N.Y. 14092

PHONE 416-497-6493

FAX 416-497-1988

Circle 155 on Reader Service Card

MODULAR DATA ACQUISITION



- FOR IBM & Compatibles
- Flexible and Inexpensive
- Money Back Guarantee
- Free Technical Support

Fast Delivery
1-800-553-1170

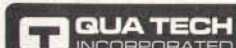

Leaders in Communication Technology
 478 E. Exchange St., Akron, OH 44304
 (216) 434-3154 TLX: 5101012726

Circle 268 on Reader Service Card

NEW

PARALLEL PORT FOR PS/2



MODELS 50, 60, 80

- LPT1, LPT2, LPT3
- Optional Serial Port
- OEM Pricing Available

1-800-553-1170

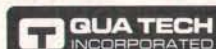

478 E. Exchange St., Akron, OH 44304
 TEL: (216) 434-3154 FAX: (216) 434-1409
 TLX: 5101012726

Circle 269 on Reader Service Card

Fix common problems fast!

You don't need to be an expert to diagnose and correct problems involving PC setup. All you need is HELPMETM software! More than 300 tests. On-screen help for understanding and correcting identified problems. Quick identification of system configuration and compatibility. \$99 plus shipping and handling. MC and VISA accepted. California Software Products, Inc., 525 N. Cabrillo Park Drive, Santa Ana, CA 92701 (714) 973-0440.

Circle 60 on Reader Service Card
(DEALERS: 61)

MAXELL

100% CERTIFIED
5 1/4" BULK DISKS

5 1/4" DS/DD 59¢

3 1/2" DS/DD 1.09

Price based on quantity of 300 includes sleeves, labels and tabs.

800-222-0490

In NJ 201-462-7628
FAX 201-462-5658

- 24 Hour Shipment •

MEGA Soft

P.O. Box 710, Freehold, NJ 07728

Circle 211 on Reader Service Card

**BUY QUALITY
FOR LESS!**

DYSAN

5 1/4" DS/DD 39¢

100% CERTIFIED
LIFETIME WARRANTY

Price based on quantity of 250 in bulk includes Tyvek sleeves and label kits.

800-222-0490

In NJ 201-462-7628
FAX 201-462-5658

- 24 HOUR SHIPMENT •

MEGA Soft

P.O. Box 710, Freehold, NJ 07728
Full service duplication facility

Circle 212 on Reader Service Card

CHIPCLOCK™

10-year clock/calendar IN A CHIP!

Easy plug-in ■ 10-year battery
 Never set date/time again
 No slot needed ■ 100% compatible

NOW WORKS WITH PS/2

CHIPCLOCK w/software NOW \$49.00

30-day money-back guarantee

COMPUQUEST INC.

801 Morse Ave. ■ Schaumburg, IL 60193

1-800-722-2353

1-312-529-2552 in IL

Circle 73 on Reader Service Card



We are proud to feature Top Performing Products at

LOW PRICES!

Computer Systems

Jade Turbo Xt 10 MHz	\$398
Jade Turbo 286 10 MHz	\$998
AST model 80/140/170	Call
Everex 386 16 MHz	\$1848
Everex 386 20 MHz	Call
Compaq DeskPro	Call
Compaq Portables	Call
IBM PS/2 models 30/50/60/80	Call

Disk Drives

360K half high	\$68
360K full high	\$88
TEAC 55 BV	\$78
1.2 MB for AT	\$88
3 1/2" 720K	\$88
3 1/2" 1.44 MB	\$118
5 1/4" ext. 360K for PS/2	\$218
5 1/4" ext. 1.2 MB for PS/2	\$258

Hard Disk Drives

10 MB w/controller	\$198
20 MB w/controller	\$268
30 MB w/controller	\$288
40 MB w/controller	\$398
40 MB for AT	\$338
ST 125 20 MB	\$248
ST 138 30 MB	\$298
ST 251-1 40 MB	\$368
ST 251-1 40 MB	\$448
ST 4096 80 MB	\$548

Tape Back-up

Mountain 40 MB XT	\$378
Mountain 40 MB AT	\$378
Mountain external 40 MB	\$498
CMS 60 MB tape	\$498

Monitors

Amdek 310A amber	\$98
Amdek 410A	\$158
14" amber flat screen	\$128
RGB 640 x 240 color	\$258
EGA 640 x 350 color	\$378
VGA 800 x 560	\$488
NEC MultiSync GS	\$188
NEC MultiSync II	\$588
NEC MultiSync Plus	\$888
NEC MultiSync XL	\$2068
Mitsubishi Diamond Scan	\$498
Zenith 1490 flat	\$608

Terminals

WYSE model 30	\$288
WYSE model 50	\$368
WYSE model 85	\$438

Keyboards

84 Key AT-Style	\$68
101 Key Enhanced	\$78

Printers

EPSON LX-800 9 PIN	\$188
EPSON FX-850	Call
EPSON FX-1050	Call
EPSON EX-800	Call
EPSON FX-286e	Call
EPSON LQ-500 24 PIN	\$338
EPSON LQ-850	Call
EPSON LQ-950	Call
EPSON LQ-1050	Call
EPSON LQ-2550	Call
EPSON SQ-2500	\$398

Okidata 320	\$338
Okidata 321	\$468
Okidata 390	\$468
Okidata 391	\$638
Okidata 393	\$928

Citizen 120D	\$158
Citizen 180D	\$168

NEC P2200	\$348
NEC P5200	\$518
NEC P5300	\$688

Toshiba 321 SL	\$488
Toshiba 341 SL	\$598
Toshiba 351 SX	\$948

Diconix 150 Portable	\$308
----------------------	-------

Daisywheel Printer

40 CPS Parallel and Serial	\$298
----------------------------	-------

Hewlett Packard DeskJet

DeskJet	\$698
128K PDP Desk RAM	\$98
EPSON emulation cartridge	\$68
TMS RM/HELV Soft Font	\$98
Ink cartridge	\$19

Hewlett Packard LaserJet

LaserJet II	\$1698
25 in One Font Cartridge	\$398
4 MB card w/o memory	\$188
1 MB memory card	\$348
2 MB memory card	\$648
4 MB memory card	\$1148
Toner cartridge	\$98

Buffers

EPSON/Comrex 128K	\$98
Quadram Microfazer 8K	\$128
Quadram Microfazer 64K	\$128
Quadram Microfazer 128K	\$228
Quadram Microfazer 512K	\$598
Logical Connection 256K	\$448
Logical Connection 512K	\$528

Joystick

Kraft 3 button Joystick	\$18
Kraft 3 button Joystick	\$28

Plotters

Roland DXY-885	\$898
Houston Instruments	Call
Hewlett Packard all models	Call
Cal Comp all models	Call

Scanner

Logitech Scan Man	\$248
Diamond Flower 3000	Call
Princeton LS-300	\$760
Hewlett Packard ScanJet	Call
Microtek all models	Call
Dest 1020/2020	Call

Digitizers

Summa Sketch 12 x 12	\$378
Summa Sketch 12 x 18	\$638
Kurta all models	Call
Cal Comp all models	Call

Mouse

with Software **\$29**

LogiTech

LogiMouse Bus	\$78
LogiMouse Serial	\$78
LogiMouse Hi-res	\$88

Mouse Systems

PC Mouse with Paint	\$88
---------------------	------

Microsoft

Mouse w/Paintbrush	\$98
Mouse w/CAD	\$108
Mouse w/Window	\$128

Complete PC

Complete Hand Scanner	\$178
Complete FAX Board	\$348
Complete Answering Machine	\$248

Switch Boxes

Parallel or Serial	
2 way AB	\$28
3 way ABC	\$38
4 way ABCD	\$58
5 way ABCDE	\$68
Crossover X	\$68
AutoSwitch 3 way	\$198
AutoSwitch 6 way	\$248

Cables

6' printer	\$12
10' printer	\$18
25' printer	\$28
9' serial	\$18
25' serial	\$28
50' serial	\$38
100' serial	\$58
Keyboard extender	\$12
Monitor extender	\$16
Printer extender	\$16

Modems

1200 internal w/software	\$58
2400 internal w/software	\$98
1200 external	\$88
2400 external	\$158
2400 PS/2 internal	\$178
Intel 2400B for PS/2	\$278

Intel

Above board PC 64K	\$268
Above board 286 512K	\$368
In board 386	\$1098
8087 5 MHz	\$98
8087-2 8 MHz	\$148
8087-1 10 MHz	\$198
80287-6 8 MHz	\$178
80287-8 10 MHz	\$238
80287-10 12 MHz	\$278
80387-16 16 MHz	\$448
80387-20 20 MHz	\$678
80387-25 25 MHz	\$878

Boards

Monographics w/Parallel	\$48
Color Graphics w/Parallel	\$48
EGA card	\$138
VGA card	\$248
AST EGA Par/Ser/Clock	\$168
Dual game port	\$18
XT I/O Par/Ser/Clk/Game	\$58
AT I/O Par/Ser/Clk/Game	\$58
360/720K 1.2/1.44 MB	\$48
AT FDD/HD controller	\$128
XT Hard Disk controller	\$58
AST SixPak Plus	\$118
AST XFormer	\$578
Intel Above board 286	\$378
Paradise auto EGA	\$158
Paradise VGA	\$258

Surge Protection

Isobar 4 outlet	\$48
Isobar 8 outlet	\$68
Isobar modem protector	\$24
S.L. Waber 6 outlet	\$18

TrippLite Battery Back-up

450 Watt UPS	\$398
750 Watt UPS	\$498
1200 Watt UPS	\$698

TrippLite Line Stabilizer

600 Watt LC	\$98
1200 Watt LC	\$158
1800 Watt LC	\$188

Accessories

Kensington Master Piece	\$88
Kensington Master Piece Plus	\$98
Vertical CPU stand	\$18
Keyboard drawer	\$58
Monitor Tilt-n-Swivel	\$18
Printer muffler 80	\$48
Printer muffler 132	\$68
Printer stand 80	\$9
Printer stand 132	\$14

4901 W. Rosecrans Ave. Box 5046
Hawthorne, California 90251-5046



California

Torrance, Santa Ana, Woodland Hills
Kearny Mesa, Sunnyvale

Texas

Addison, Houston

Georgia Arizona
Smyrna Phoenix

Not all items in stock at
our nine retail locations.



Place orders and use our technical support toll free!

Continental U.S.A. 1-800-421-5500/Inside California 1-800-262-1710

Fax machine 1-213-675-2522/All others 1-213-973-7707

We accept checks, credit card or purchase
orders from qualified firms and institutions.
No surcharge on credit card orders. CA., TX.
GA. & AZ. residents add sales tax. Prices and

availability subject to change without notice.
Shipping and handling charges via UPS
ground 50¢/lb. UPS air \$1.00/lb. Minimum
charge \$3.00.



UNIVERSAL E(E)PROM PROGRAMMER \$ 495

- No personality modules; Device selection by menu.
- Built-in Eraser/Timer option (\$50); Foam pad.
- Direct technical support; Full 1 year warranty.
- Stand alone duplication & verify (24/28 pins).
- Quick pulse algorithm (27256 under 60 sec).
- All 24/28 pin parts to 1 Mbit; CMOS; EEPROMS.
- 8741, 2, -4, -8, -8H, -9, -9H, -51, -C51, -52, -55, 9761 & more.
- IBM-PC, Apple, CPM or Unix driver; Autobaud RS232.
- Offset/split Hex, Binary, Intel & Motorola 8,16,32 bit.
- Kits from \$95. Manual with complete schematics. Call today for datasheets !!

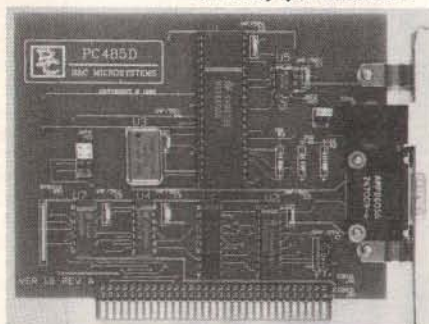

PC485D \$95

[RS 485/422 INTERFACE]

- Meets the EIA RS-485 standard for multipoint bus transmission and the EIA RS-422A standard.
- Can be configured as COM1 or COM2.
- Line terminators are jumper selectable.
- High speed differential drivers allow fast data transfer over long cables (over 4,000 ft). Max. Baud rate 56KB/115KB.
- Tri-state line drivers permit implementation of LANs.
- Two wire (half duplex) operation. DB9 or phonejack.
- Sample communication software available. (\$50)

PC488A \$145

[IEEE - 488 INTERFACE]

- Includes INSTALLABLE DOS DEVICE DRIVERS and software support for BASIC.
- Optional language support for C, PASCAL, FORTRAN and ASSEMBLY - \$50
- Selectable base I/O address, IRQ and DMA.
- CONTROLLER / TALKER / LISTENER capability.
- Customer support via dedicated 24 hours B&C Microsystems BULLETIN BOARD.
- Compatible with most IEEE-488 Software Packages for the IBM-PC (e.g. ASYSTANT GPIB, Lotus Measure, etc.).
- Hardware compatible with NI's GPIB - PCIIA.

PC488B \$345

**[IEEE - 488 CARD WITH]
[BUILT-IN BUS ANALYZER]**

- GPBASIC package complements IBM/Microsoft BASIC interpreter and compiler to create a programming environment similar to HP desktop computers.
- Additional libraries of over 20 high level 488 dedicated functions for C, Pascal or Fortran available (\$50).
- Powerful menu-driven bus analyzer, which can run in the foreground or in the background while 488 programs or commands are executed, features program stepping, break points and real time bus data capture (4k circular buffer).
- Instant toggling between foreground and Analyzer screen.
- Complete Talker/Listener/Controller capability.
- Dipswitch selectable Base Address, IRQ, DMA.

MC/VISA/AMEX

Call today for datasheets!

B&C MICROSYSTEMS INC.

355 West Olive Ave, Sunnyvale, CA 94086
PH: (408)730-5511 FAX: (408)730-5521 TELEX: 984185

PALMERASE™
World's Smallest UV Eraser

\$4995



PALMERASE™ can erase 20, 24, 28, and 40pin EPROMs in less than 3 minutes! Also, larger erasers are available to handle EPLDs, MICROs and other UV erasable devices. Please call today for more information on an eraser that's right for you.

LOGICAL DEVICES, INC.

1201 N.W. 65th Place, Ft. Lauderdale, FL 33309
1-800-331-7766 • in Florida: (305) 974-0967

Circle 189 on Reader Service Card
(DEALERS: 190)

"C"
for Z80 and HD64180
Microprocessor
Programming.

Source level debugging on a remote target!

Investigate our powerful PC-based, C compiler for embedded Z80 and HD64180 microprocessors... a compiler written for microprocessor engineers. Only \$495.00.

- Remote source debugger. \$195.00.
- Additional products: assemblers, linkers, single board computers.

Z-World
1772A Picasso Avenue
Davis, CA 95616
916 753-3722
Fax: 916 753-5141



In Germany: iSystem Tel: 08131/1687 "Z80 Specialists"

Circle 366 on Reader Service Card

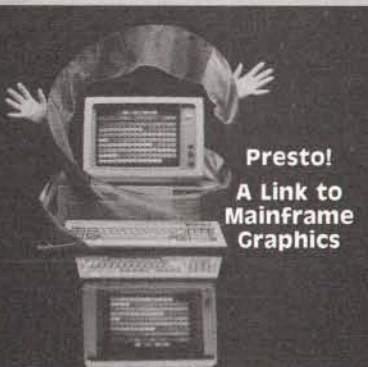

Presto!
A Link to
Mainframe
Graphics

Find out how our whole family of EMU-TEK graphics terminal emulation software makes good sense for the work you do. Call today for more information.

FTG DATA SYSTEMS

(714) 995-3900
(800) 962-3900 (800) 972-3900 (Calif.)
10801 Dale St., Suite M-2
Stanton, CA 90680

Circle 135 on Reader Service Card

the **HUSKY™**



EPROM
PLD
MICRO
GANG
SET

PC based PROGRAMMER
\$599.00*

*modules not included.

From A Name You Can Trust

LOGICAL DEVICES, INC.

1201 N.W. 65th Place, Ft. Lauderdale, FL 33309

1-800-331-7766 (305) 974-0967

Telex 383142 Fax (305) 974-8531

Circle 191 on Reader Service Card
(DEALERS: 192)

Z80 or HD64180



iC-80 In-Circuit Emulator

- Can be configured for Z80 or HD64180.
- C source code level debugging with our C compiler.
- Works with IBM-style PC.
- 64K overlay memory.
- Base price \$995.00. \$1340.00 including one probe and symbolic debug software.

Z-World, 1772 Picasso Ave, Davis, CA 95616

(916) 753-3722

Fax: (916) 753-5141.

In Germany: iSystem 08131/1687

Circle 367 on Reader Service Card

Terminal Emulation

TEK 4105 EM4105 \$349

- Tektronix 4105
- Tektronix 4010
- VT220, VT102
- Picture files
- VGA and EGA support
- High resolution hardcopy

VT220 EM220 \$169

- VT220, VT102 emulation
- File transfer
- 132 column modes
- Color support
- Hot key

■ ■ ■ **Diversified Computer Systems, Inc.**

3775 Iris Avenue, Suite 1B
Boulder, CO 80301 (303) 447-9251
FAX: 303-447-1406

Trademarks: VT102, VT220 - DEC; Tektronix - Tektronics Inc.

Circle 114 on Reader Service Card

Special !

COMPLETE-PC
ANSWERING MACHINE ... \$229
FAX -PC ... \$299
HAND SCANNER ... \$169

ups

ShipMate™ PC-Manifest System
\$199

**SAVE UP
TO 70%**

SINCE 1984

*It PAYS to
BUY-MHI!*

PRODUCTS NOT LISTED ... CALL!

CAD...etc.

PC & MAC

New Orders: 1-800-621-3999

AST Premium
286/386
Call

ZENITH 1490
FlatScreen
\$579

DRAFIX
1 Plus or 3D Module
Call

MITSUBISHI
Diamond Scan 40/70 Mb Disk
23ms
\$477 \$429

**VENTURA PAGE-
PUB 2.0 MAKER**
\$469 \$460

SWEET-P 600
6 Pen Plotter
\$589

DESIGN CAD
Standard or 3D
\$149

SMART MODEM
1200B Int. 2400B Int.
\$59 \$115

PANASONIC
1091-m2
\$195

SCANNERS
ScanMan or Complete PC
HandScanner
\$169

PRINTERS & LASERS

Canon BJ-130	689
Citizen 180-D	157
MSP-15E	295
MSP-40	269
MSP-45	389
MSP-50	345
MSP-55	440
Premiere 35	439
Tribute 124	439
Tribute 224	579
Diconix 150	299
HP LaserJet II	1690
JDL 850 Series	Call
NEC LC890	Call
Panasonic 1080i-m2	155
1091-m2	189
1592/1695	382/418
1524	515
Toshiba 321-SL	465
341-SL	609
351-SX	888
Others	Call

FastBack	75
FastBack Plus	85
FormTool	52
Freelance Plus	293
Fox Base Plus	179
GEM Draw Plus	159
Generic Cadd 3.0	48
Generic Cadd Others	Call
Harvard Graphics	255
In House Acct	107
Laplink Plus	74
Lighting Hard Disk Speedup	69

WANTED
Programs - original utilities,
applications, etc. Earn
royalties in just 90 days.
Mail or Fax your info to attn: Bill.
MS-DOS & MAC compatible only.

Ventura Publishing 2.0	469
VersaCad & Libraries	Call
Windows	Call
WordPerfect 5.0	Call
X-Tree Pro	58

DRIVES, MODEMS & FAX

Mitsubishi 40/70 Mb Hard Drive	
1/2 ht AT, 23ms	439
Panasonic FAX Board	689
Seagate ST225 w/card	260
ST238 30Mb w/card	285
Smart Modem 1200B int w/sw	58
2400B int w/sw	115
Toshiba 3.5 XT/AT 720k Drive	89
5.25 XT/AT 360k Drive	75
US Robotics Courier 2400	299

COMPUTERS

AST Premium 286 & 386	Call
Mitsubishi MP286L	Call
NEC Multispeed	1079
Multispeed EL II	1423
Multispeed HD	2209
Toshiba Laptops	Call
Zenith Laptops	Call

**LIGHTING Disk
SpeedUp**
Increase your Hard Disk
Speed as much as 40% !!!
\$69

DIGITIZERS & PLOTTERS

Calcomp 1023-GT	Call
1043-GT	5990
Digitizers	Call
Enter Sweet-p 600	598
Others	Call
Houston Instruments	Call
DMP 41/42	Call
DMP 51MP	3550
DMP 51/52MP	3200/2700
DMP 52	2300
DMP 56A	3800
DMP 61	Call
DMP 62	Call
MP Options	Call
Hitachi Puma Pad(10 Year Warranty)	
HG-12x12D-4	398
HG-12x12D-12	488
HG-15x15D-4	598
HG-15x15D-12	659
loline	Call
JDL 850 Series	Call
Kurta IS 12x12	285
IS 12x17	485
Summagraphics 12x12 Plus	335
18x12 Pro w/4 Butt & Stylus	569
Mac Bit Pad 12x12, 4But, Sty	299

BOARDS & NETWORKS

Adage AD10/4	1370
AD10/8L	2040
ArcNet	Call
Artist 8	1178
10/16	1920
12	2320
AST	Call
ATI EGA Wonder	169
VIP VGA	249
EtherNet Plus	Call
Genoa VGA 600x800	259
VGA 760x1024	379
Herules Graphics Plus	169
Intel AboveBoard 286/512k	359
AboveBoard PS 286/512k	388
Paradise EGA 480	Call
VGA Plus	Call
VGA Pro	Call
RasterOps Color Draw 24	319
ColorBoard 104	2484
ColorBoard 108	1162
Sigma Designs VGA	209
Tops Flashcard	143
Verticom	Call
Video 7 Vega Deluxe	177
V-Ram	Call

**Intel
coprocessors
genuine & new**

8087-2	132
80287-8 (<10MHz)	205
80287-10 (>=10MHz)	239
80387-16	Call
80387-20	Call
80387-25	549
80387-SX	398

MONITORS

Amdek 1280 & Card	639
210A	87
722EGA	431
Cornerstone	Call
Hitachi	Call
Mitsubishi Diamond Scan	479
Monitorm Viking	Call
NEC Multisync II	565
Multisync GS	185
Others	Call
RasterOps 1648s	1995
1948s	2949
Samsung	Call
Sigma Designs LaserView	Call
Sony Multiscan 1303	495
Zenith 1490 FlatScreen	579

SOFTWARE

AutoSketch®	59
BoeingGraph	195
By-Line	169
Carbon Copy Plus	103
Clipper	355
Copy II PC	18
Corefast	87
Dac Easy 3.0	58
dBase III+	355
DesignCad	149
Desklink	92
DesqView	69
Drafix 1 Plus	Call
Drafix 3D Mod & Options	Call
Dollars & SenDDS Back-Up Plus	33
Excell PC	281

Lotus 123 2.01	280
Lotus Agenda	Call
Managing Your Money	113
MathCad 2.0	199
MicroSoft Windows 2.0	56
MS-Dos 3.3	95
Norton Util 4.0	45
Novell Netware 286	Call
PageMaker 3.0	480
Paradox 2.0	391
PC Tools Deluxe	Call
PathMinder 4.0	55
Peachtree Accounting II	145
PFS: First Choice	77
PFS: First Publisher	54
PFS: Professional File	129
PFS: Professional Plan	51
PFS: Professional Write	102
Plan Perfect	185
Q&A	177
Q&A Write	115
Quattro	132
Rapid File	172
R:Base for DOS	419
ShipMate™ (ups Manifest)	199
SideKick Plus	Call
Smart Systemen	418
Sprint	115
Tops	101
Turbo Basic, C, or Pascal	57

Novell NetWare
Customiation ... CALL

HITACHI Digitizer
10 Year Warranty
HDG-1212D-4
Includes:
4-Butt Cursor, 1-Butt Pen
& Mouse Emulator.
\$398

**CAD CORNER
SPECIAL**
AST Premium 286/140
DiamondScan Monitor
Summagraphics 12x12 Plus
Intel 80287 Chip
\$3360

NEW! Optical Disk Interface / 40ms

Filesize up to 21 GigaBytes and limited by Disk Only. Speed resembles a 40ms Hard Drive. OptiDriver supports most Optical drives including ATG GigaDisk, ISI 525WC, LMSI LD-1200, Maxtor TXT 800S, Mitsubishi MW-5UJ, Optimum 1000, Optotech 5984, Panasonic LF-5000, Ricoh RO-5040W, Sony WDD-3000. Host Adapters supported include Adaptec, Future Domain, Rancho Technology, Scientific Micro Systems, and Western Digital. Opti-Driver is an applications interface for attaching optical disk drives to an IBM PC/XT/AT or compatible computer system. Low memory usage, approximately 50kb, is required for the master program. NASA is now a proud user of this revolutionary interface. Kit includes OptiDriver, Host Adapter, and Manual. Installs as drive "O" with batch file.

\$525 \$695 list

**Volume Bids
Welcome!**

VISA
MASTERCARD
PO's
Just Call First.

MHI Warehouse, Inc.
8129 N. 35th Ave. #2-306
Phoenix, AZ 85051

New Orders:
1-800-621-3999
Order Info: 602-997-8877

Fax: 602-943-3833

Pre-approved P.O.'s are welcome. Prices reflect cash discount and are subject to change without notice. Product compatibility, warranties, & claims are responsibility of manufacturer only. All returns are subject to a restocking fee. Personal/Company checks delay shipping. AZ orders only add 6.7% tax. Orders are processed same Day. International orders Call (602) 861-1090.

This could be the most productive phone number you call today. Toll free. 1 (800) 531-5369

(Or, if you prefer to FAX your order—1 (512) 344-2985.)

TrippLite® Battery Back-Ups

Protect your equipment and data by providing safe shut down time for your computer systems and other sensitive equipment during black or brown-outs. Data loss from one black-out can cost you hundreds, if not thousands of dollars. These units feature AC line spike and noise suppressors, status indicator lights and heavy gel-cell batteries—a regulated battery charger automatically restores battery to full charge when AC power returns.

\$1299.00

\$239.00 **\$299.00** **\$599.00** **\$799.00** **\$399.00**

BC-200 200-W **BC-325 325-W** **BC-750 750-W** **SC-BC-2000 2000-W** **BC-1200 1200-W** **BC-450 450-W**

This complete TrippLite® Series offers reliable battery back-up at an extremely low price.

TrippLite® Voltage Regulator—Line Conditioners

\$79.00 **\$149.00** **\$199.00**

LS-600 **LC-1200** **LC-1800**

TrippLite® Line Stabilizer/Conditioners automatically adjust varying input voltage to provide full voltage support during a low voltage condition while suppressing spikes and line noise.

Cable Assemblies

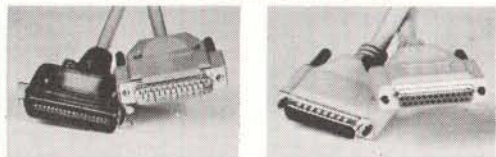

PC/AT Parallel Printer Cables			DB-25 - 25 Line Cables Male-Male		
Stock #	Length	Price	Stock #	Length	Price
PPC301-6	6 ft.	\$ 6.95	25MM-6	6 ft.	\$ 6.95
PPC301-10	10 ft.	7.95	25MM-10	10 ft.	7.95
PPC301-15	15 ft.	11.95	25MM-25	25 ft.	17.95
PPC301-25	25 ft.	17.95	25MM-50	50 ft.	33.95
PPC301-6RA	6 ft.	12.95	25MM-100	100 ft.	62.95

POPULAR CABLES DB-25 - 25 Line Cables Male-Female

Stock #	Description	Price	Stock #	Length	Price
MEC-6	Monitor Ext.	\$5.95	25MF-6	6 ft.	\$ 6.95
KEC-6	Keyboard Ext.	3.95	25MF-10	10 ft.	7.95
ACPC-03	Power Adapter	4.95	25MF-25	25 ft.	17.95
ATM-6	AT Modern Cable	5.95	25MF-50	50 ft.	33.95
	call Other cables available		25MF-100	100 ft.	62.95

Altex Electronics, Inc. "Your Electronics Supply House"

TERMS: Minimum order \$10.00. We accept Mastercard, Visa, and American Express at no additional charge. For C.O.D. orders, add \$2.20. For orders under \$100.00, add \$3.00 handling and actual UPS shipping charges. For orders over \$100.00, we pay handling charge—you pay actual UPS shipping charges plus insurance. Purchase orders accepted from approved accounts. All returns require an RMA# and are subject to a restocking fee. Texas residents add 7.5% sales tax. Prices subject to change and we are not responsible for typographical errors.

Store Hours: 8:00-6:00 M-F, 10:00-2:00 SAT CST
10731 Gulfdale, San Antonio, Texas 78216

OMNI Power Director



CC16-P \$79.95

TrippLites' ISOBAR command console provides the highest level of surge and noise suppression of any console unit on the market today. Features include 6 outlets, 5 lighted power switches, protection indicator light, 15 amp circuit breaker and 12-foot power cord.

Eprom Programmer

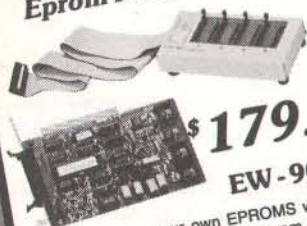

\$179.95
EW-904

You can program your own EPROMS with this EPROM programmer—it can program up to 4, 16K thru 512K EPROMS simultaneously—easy to use software is included.

Eprom Eraser



\$79.95

You can erase your EPROMS quickly and easily at home or workplace with this easy to use EPROM eraser with built-in timer. It features an adjustable exposure time with alarm and is static protected.

Without timer
LA-6A
\$59.95

Hard Drive Cases

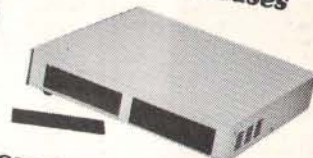

SDH-2H \$99.00

This sturdy metal cabinet is capable of handling up to two 1/2 height hard disk drives—supplies complete with fan, switching power supply and mounting hardware. (Drive cables not included) 14 7/8" W X 13 7/8" D X 2 3/8" H.

Switchboxes



These sturdy metal switchboxes allow you to share computers, printers and other peripherals quickly and easily. They have gold-plated contacts and are EMI-RFI protected.

DB-25 25 Line Switchboxes

Stock #	Description	Price
AB25-2	Two position	\$19.95
AB25-3	Three position	25.95
AB25-4	Four position	28.95
AB25-5	Five position	38.95
AB25-6	Six position	59.95
AB25-X	Cross over	29.95

Centronics 36 Line Switchboxes

Stock #	Description	Price
AB36-2	Two position	\$23.95
AB36-3	Three position	29.95
AB36-4	Four position	34.95
AB36-5	Five position	44.95
AB36-X	Cross over	37.95

We carry a complete line of switchboxes for your different requirements. Call for more information!

Compu\$ave



1-800-877-8855

BOARDS

Adv. Dig. Slave 545 Orchid Designer 329
 Alloy Slave 599 Panasonic Fax 642
 AST 5251-11E 545 Paradise 480 Auto 169
 AST Hot Shot 286 369 Paradise VGA+ 249
 ATI VGA Wonder SAVE Paradise VGA Pro 352
 ATI EGA Wonder 192 STB VGA EM 512K 299
 BOCA RAM AT 142 Sigma VGA H 242
 Genoa VGA HiRes 375 Video 7 V RAM 485
 Intel Above Board Call Video 7 Vega VGA 249
 Adaptec/Artist/Hercules/Metheus/Number 9 CALL
 Quadram/Talltree/West. Digital/Verticom/VMI CALL

DISK DRIVES

CDC 150 Mb 1,445 PlusCard 40Mb 655
 Miniscribe 40Mb 295 Seagate 20Mb Kit 262
 Miniscribe 6053 545 Seagate 30M bKit 279
 Miniscribe 71 Mb 635 Seagate ST251-1 435
 Mountain TD 4440 379 Seagate 4096 599
 PlusCard 20Mb 518 Toshiba 720 K, 3.5" Kit. 89
 AST/Archive/Alloy/Genoa/Iomega/Micropolis CALL
 Maynard/Maxtor/Tallgrass/Tecmar CALL

SOFTWARE

Carbon Copy+ 5.0 107 Multimate Advan. II 257
 Database III Plus 393 Paradox 2.0 412
 Fastback 711 94 Peachtree Complete 145
 First Publisher 2.0 75 Quattro 139
 Harvard Graph 2.1 254 R:Base for OS2 545
 LOTUS 123 CALL Symphony CALL
 Microsoft Excel-PC 289 Top for DOS 105
 Microsoft Works 96 Ventura Publisher 495
 Microsoft Word 4.0 209 WordPerfect 5.0 229

COMPUTERS

Acer 20 Mhz CALL Sharp 4502 1135
 AST Model 80 1575 Toshiba 1000 769
 AST Model 300 2777 Toshiba T1200F 1469
 AST Model 340 3999 Toshiba T1200H 2249
 Intel 25 Mhz CALL Toshiba 3100/20 2995
 NEC EL II 1450 Toshiba 3200 3750
 Packard Bell 12 Mhz 1279 Toshiba 5100 4899
 Samsung 20 Mhz 2899 Zenith Supersport 1625
 Samsung Laptops SAVE Zenith Supersport 286 3395
 Acer 80386: 16 Mhz / 0 Wait / 1 Mb Ram / 40 Mb 3299
 Mitsubishi 286: 12 Mhz / 40 Mb Hard Drive 1925
 Mitsubishi MP286 Laptop : 20 Mb 2337
 NEC Powermate Portables CALL
 Sperry PC IT : 512kb / 44Mb HD / Keyboard 2795
 Samsung S500 AT: 10Mhz / 40Mb Drive 1565
 Televideo 386: 16 Mhz / 2Mb / 1.2Mb Drive 2595
 Wyse 2108: 8 Mhz / 512Kb / 1.2Mb Drive 1195
 Wyse 2112: 12.5 Mhz / 1Mb / 1.2Mb Drive 1659
 Wyse 2214: 12.5 Mhz / 0 Wait / 1.2Mb Drive 1895
 Wyse 3216: 16 Mhz / 1Mb / 1.2Mb Drive / 0 Wait 2795
 Unisys 386: 16 Mhz / 1Mb / 1.2Mb Drive / 0 Wait 2695
 Altos & Other Models CALL

TERMINALS

Altos V 485 Televideo 965 412
 Adds 1010 299 Wyse 30 289
 IBM 3151 389 Wyse 50 355
 Kimtron KT-70 PC 359 Wyse 60 395
 Televideo 905 289 Wyse 85G 379
 Televideo 955 375 Wyse 99GT 469
 Visual/CIE/Link/Qume/Falco CALL

PLOTTERS

Calcomp 1023GT 3785 HP 7475 A 1395
 Calcomp 5902 3395 HP 7550 A 2895
 Calcomp 1044GT 10,245 HP 7595 7795
 Houston DMP 52 2399 Ioline 3700 3065
 Houston 41/42 2110 Ioline 4000 3995
 Houston 56A 3850 JDL 850 2869
 Houston 61 3025 Roland 980 1195
 Houston 62 4495 Roland 880 929
 Numonics/Taxan/Versatec/JDL/Other Models CALL

DIGITIZERS

Calcomp12 x12 365 Logitech HiRes Mouse 92
 Calcomp 44 x 60 3745 Kurta IS 3 CALL
 Calcomp36 x 48 3195 Kurta IS 8.5 x 11 249
 GTCO 24 x36 1945 Kurta IS 12 x 12 309
 GTCO 36 x 48 2395 Kurta IS 12 x 17 535
 Hitachi 11 x 11 439 Summa 12 x 12 + 348
 Logitech C7 Mouse 79 Summa 12 x 18 599

MODEMS

ATI ETC. 155 Practical 12001 65
 Anchor 2400E 145 Prometheus 2400B/2 129
 Avalex 1200 Ext 95 Prometheus 2400G 149
 Hayes 1200 279 Racal-Vadic 2400VP 388
 Hayes 2400 415 USR 2400E 345
 Incomm T2400 235 USR Courier 2400 299
 Migent Pocket 109 USR HST 9600 649
 Multitech 224 EH 388 USR Sportster 1200 85
 Multitech 224 EC 305 Ven-Tel 18000 939
 Novation Parrot 85 Zoom 2400 HC 139
 Avatech/Case/UDS/Other Models CALL

PRINTERS

Alps Allegro 24 354 NEC 5300 679
 Alps 324 E 745 NEC P5XL 835
 Canon BJ 130 669 NEC P9XL 1038
 Citizen120D 142 Panasonic 1080M2 165
 Citizen 180D 162 Panasonic 1091M2 189
 Citizen MSP 15E 319 Panasonic 1524 549
 Citizen MSP 55 505 Star NX-1000 171
 Fujitsu DL3400 525 Star NX-2400 318
 Okidata 320 345 Toshiba P351SX 979
 Okidata 393 959 Canon 811 Lazer 1565
 NEC 2200 328 NEC LC 890 3165
 NEC 5200 515 HP Lazer Jet II SAVE
 Brother/C.Itoh/Data Products/Diconix CALL
 Epson/Genicom/QMS/OTC/Variyper/TI CALL

MONITORS

Amdek 310A 69 PGS LM 300 539
 Amdek 1280 645 Samsung TTI 79
 Intercolor 19"VGA 1595 Sigma Laser 19" 1765
 Mitsubishi 1381A 509 Sony Multiscan Call
 Mitsubishi 20" Auto CALL Seiko 1430: 635
 NEC Multisync II 565 Tatung Multiscan 475
 NEC Multisync + 915 Taxon 770 + CALL
 NEC Multisync XL 2089 Thomson 4160 RGB 209
 NEC Multisync GS 179 Wyse 650 VGA 459
 PGS Ultra Sync 522 Wyse 700 678
 PGS UltraSync 16" 895 Zenith 1490 598
 Other Models CALL

SCANNERS

Datacopy 730 1095 PGS LS-300+ OCR 965
 AST / HP / Taxan / PC Hand Scanner CALL

HOURS: MON-FRI 7 AM-6 PM, SAT: 9 AM-2 PM. Prices reflect cash discounts and are subject to change without notice. We do not guarantee compatibility. DOA's Are repaired or replaced at our discretion. RMA required for all returns. Major credit cards and selected PO's are accepted. INTERNATIONAL ORDERS ARE WELCOME. CUSTOMER SERVICE (602)437-4856 - FAX (602)437-9685.

<h3>DATA SWITCHES</h3>  <p>\$19⁹⁵ UP</p> <p>DS-252 AB, 25 pin \$19⁹⁵ DS-254 ABCD, 25 pin \$29⁹⁵ DS-362 AB, Centronics \$24⁹⁵ DS-364 ABCD, Centronics \$34⁹⁵ DS-902 AB, 9 pin \$22⁹⁵ CB-252 Crossover, 25 pin \$29⁹⁵ CB-362 Crossover, Centronics \$34⁹⁵</p>	<h3>PRINTER CABLES</h3>  <p>\$4⁹⁵ UP</p> <p>PR-1806 6 foot \$4⁹⁵ PR-1810 10 foot \$7⁹⁵ PR-1815 15 foot \$11⁹⁵ PR-1825 25 foot \$19⁹⁵ PR-1850 50 foot \$34⁹⁵ PR-RT06 6 foot right-angle \$9⁹⁵</p>	<h3>FLOPPY DISK CABINET</h3>  <p>\$22⁹⁵</p> <ul style="list-style-type: none"> • 3 Drawers • Capacity 300 5 1/4" Diskettes • Sturdy wood-product construction with plastic drawers • 6 1/2" x 19 1/2" x 12 1/2" (HxWxD) • Will also hold compact discs • Part Number: WD-301 	<h3>COMPUTER COVERS</h3>  <p>\$4⁹⁵ UP</p> <p>CC-050 84-Key Keyboard \$4⁹⁵ CC-051 101-Key Keyboard \$4⁹⁵ CC-080 Printer \$5⁹⁵ CC-100 Computer and Monitor \$8⁹⁵ CC-132 Wide Carriage Printer \$6⁹⁵ CC-200 Monitor (small) \$5⁹⁵ CC-201 Monitor (large) \$6⁹⁵ CC-300 Computer (w/o Monitor) \$6⁹⁵</p>	<h3>SURGE PROTECTOR POWER STRIP</h3>  <p>\$9⁹⁵</p> <ul style="list-style-type: none"> • Six Outlets • Lighted Rocker Switch • 15 AMP Circuit Breaker • UL Approved • Part Number: SP-300 	<h3>Genius/Mouse GM6 + PACKAGE WITH DR. HALO III</h3>  <p>\$49⁹⁵</p> <ul style="list-style-type: none"> • Genius 3-button Dyna Mouse • Dr. Halo III Software • Menu Maker Software • Mouse Pad • Mouse Pocket • 100 - 800 dots per inch • 25 pin female connector • Part Number: SM-600
<h3>GENDER CHANGERS AND ADAPTERS</h3>  <p>\$4⁹⁵ UP</p> <p>GC-25MM DB25 M/M \$4⁹⁵ GC-25F DB25 F/F \$4⁹⁵ GC-09MM DB9 M/M \$4⁹⁵ GC-09F DB9 F/F \$4⁹⁵ FM-0925 DB9 F to DB25 M \$6⁹⁵ MF-0925 DB9 M to DB25 F \$6⁹⁵ FM-2536 DB25 F to 36 pin M \$7⁹⁵</p>	<h3>RS-232 MALE TO MALE CABLES</h3>  <p>\$5⁹⁵ UP</p> <p>MM-2503 3 foot \$5⁹⁵ MM-2506 6 foot \$6⁹⁵ MM-2510 10 foot \$8⁹⁵ MM-2515 15 foot \$11⁹⁵ MM-2525 25 foot \$19⁹⁵ MM-2550 50 foot \$34⁹⁵</p>	<h3>RS-232 MALE TO FEMALE CABLES</h3>  <p>\$6⁹⁵ UP</p> <p>MF-2506 6 foot \$6⁹⁵ MF-2510 10 foot \$8⁹⁵ MF-2515 15 foot \$11⁹⁵ MF-2525 25 foot \$19⁹⁵ MF-2550 50 foot \$34⁹⁵</p>	<h3>DISK DRIVE HEAD CLEANING KIT</h3>  <p>\$4⁹⁵ UP</p> <ul style="list-style-type: none"> • Easy to use • Contains cleaning diskettes and fluid • 15 cleanings DC-514 For 5 1/4" Drives \$4⁹⁵ DC-312 For 3 1/2" Drives \$5⁹⁵ 	<h3>SURGE PROTECTOR POWER CENTER</h3>  <p>\$29⁹⁵</p> <ul style="list-style-type: none"> • Six lighted rocker switches • 15 AMP Circuit Breaker • To be placed under monitor • 12 1/2" x 2 1/2" x 13 6/8" (HxWxD) • UL Approved • Part Number: SP-500 	<h3>HAND GRIP JOYSTICK</h3>  <p>\$24⁹⁵</p> <ul style="list-style-type: none"> • Three buttons • Suction cup feet • 4 1/4" foot cord • 15 pin male connector • For use with IBM's and compatibles JS-908 Joystick \$24⁹⁵ CD-215 Two Port Game Card \$16⁹⁵
<h3>36 PIN CENTRONICS MALE TO MALE CABLES</h3>  <p>\$7⁹⁵ UP</p> <p>MM-3606 6 foot \$7⁹⁵ MM-3610 10 foot \$9⁹⁵ MM-3615 15 foot \$12⁹⁵ MM-3625 25 foot \$19⁹⁵ MM-3650 50 foot \$34⁹⁵</p>	<h3>PS/2 ADAPTERS AND EXTENSION CABLES</h3>  <p>\$8⁹⁵ UP</p> <p>PS-0506 AT Keyboard to PS/2 Adapter \$9⁹⁵ PS-0915 DB9 Monitor to PS/2 Adapter \$9⁹⁵ PS-6915 6' DB9 to 15 pin \$11⁹⁵ PS-0606 6' PS/2 Keyboard Extension \$8⁹⁵ PS-1515 6' PS/2 Monitor Extension \$9⁹⁵</p>	<h3>MONITOR & KEYBOARD EXTENSION CABLES</h3>  <p>\$4⁹⁵ UP</p> <p>KB-0506 6' keyboard Ext. \$4⁹⁵ KB-0512 12' keyboard Ext. \$7⁹⁵ MR-0906 6' Monitor Ext. \$6⁹⁵ MR-0912 12' Monitor Ext. \$8⁹⁵</p>	<h3>COMPUTER FLOOR STAND</h3>  <p>\$14⁹⁵</p> <ul style="list-style-type: none"> • Adjustable Supports (4 1/4" to 7 1/4") • Accommodates both AT and XT compatibles • Molded Plastic Construction • Part Number: CS-200 	<h3>COMPUTER STAND KEYBOARD DRAWER</h3>  <p>\$34⁹⁵</p> <ul style="list-style-type: none"> • Reinforced 20 gauge steel platform • Ball bearing slides • Will hold keyboards up to 20 1/2" x 10 1/2" x 2 1/2" (WxDxH) • Overall dimensions: 22" x 15 1/2" x 3 1/2" (WxDxH) • Part Number: KD-100 	<h3>120 CAPACITY 5 1/4" DISKETTE CASE</h3>  <p>\$9⁹⁵</p> <ul style="list-style-type: none"> • DH-070 5 1/4" 70 capacity (lengthwise) \$6⁹⁵ • DH-120 5 1/4" 120 capacity (side by side) \$9⁹⁵ • DH-350 3 1/2" 50 capacity (lengthwise) \$6⁹⁵ • DH-351 3 1/2" 100 capacity (side by side) \$9⁹⁵

• VISA, MC, UPS COD, PREPAYMENT
 • SHIPPING: Exact UPS plus \$1.90 per order handling
 • COD'S: \$3.50 additional per shipping carton, cash or cashier's check
 • 15% restocking fee on return merchandise
 • Prices and availability subject to change

(916) 441-1568

HOURS: M-F 8 am - 5 pm PST

National Computer Accessories
 1609 Dreher Street, Unit E • Sacramento, CA 95814

DiskMASTER®

The Ultimate Diskette Value ...



Discover the Difference ...
2 FOR 1 LIFETIME WARRANTY

- ✓ Pkg'd in 6 different colors, bulk or boxed **COLOR**
- ✓ 100% tested and certified
- ✓ Guaranteed clipping level of 65% or above
- ✓ Includes tyvek envelopes (not paper), write protect tabs and user labels
- ✓ Quality at affordable prices

5-1/4" - 48 TPI DS-DD	BULK COLOR OR GRAY	DS-HD 96 TPI IBM-AT Compatible
.49		.90
.59	BOXED COLOR	.99

CENTECH® America's Premium Quality Color Diskettes

- ✓ TIMELESS WARRANTY
- ✓ 75%+ clipping level guaranteed
- ✓ Each disk 100% tested and certified
- ✓ 18 COLORS for data organization
- ✓ Pkgs. include sleeves, w/p tabs, & ID labels

5-1/4" - 48 TPI DS-DD	PLASTIC STORAGE BOX COLOR	DS-HD 96 TPI IBM-AT Compatible
.84		1.39
.63	BULK COLOR	1.15
3-1/2" - 135 TPI DS-DD COLOR	PLASTIC STORAGE BOX	3-1/2" - 135 TPI BLACK DS-HD
1.75		4.50

BASF

5-1/4" 48 TPI DS-DD	DS-HD 96 TPI IBM-AT Compatible
.64	.94
3-1/2" DS-HD	3-1/2" DS-DD
4.50	1.34

Call for best prices on Data Cartridges & Pelikan Ribbons

5-1/4" 48 TPI DS-DD	DS-HD 96 TPI IBM-AT Compatible
.72	1.48

Nashua

5-1/4" 48 TPI DS-DD	DS-HD 96 TPI IBM-AT Compatible
.47	*.84*

BULK

32¢ 5-1/4" DS/DD 48 TPI
Exceeds ANSI specifications + 6¢ FOR TYVEK

ORDERING INFORMATION

TERMS: P.O. orders accepted, government and schools on net 30. SHIPPING: U.S. orders add \$3.00 per 100 diskettes or fraction thereof, add \$3.00 for COD orders.

PRICE PROMISE: We will better any lower delivered price on the same products and quantities advertised nationally.

Toll Free Order Line: **1-800-233-2477** Information Line: **1-801-561-0092**

DISC INTERNATIONAL

SUPPLY COMPANY
1376 W. 8040 S. / WEST JORDAN, UT 84088
HRS: 8 AM TO 5 PM (MTN. TIME)



GANG/SET (E)EPROM MULTIPROGRAMMERS™

Model 135-E: **\$995.00***
Others from **\$345***

- Model 135 is a SET Programmer, GANG Duplicator, & UNIVERSAL Device Programmer.
- Programs virtually all 24, 28, & 32-pin (E)PROMs.
- RAM expandable to 2MegaByte.
- Optional support for 40-pin EPROMs, Bipolar PROMs, 40-pin Micros, & (E)PLD/GAL/FPLA's.
- DATA I/O* protocal compatibility.
- 18-Month WARRANTY & 12-Month FREE Device Updates.

1-800-523-1565

In Florida: 1-407-994-3520

BYTEK CORPORATION
1021 S. ROGERS CIR., BOCA RATON, FL 33487
FAX: (407) 994-3615 Telex: 4998369 BYTEK
* U.S. Prices only * DATA I/O is a registered Trademark of DATA I/O

Circle 57 on Reader Service Card

DYNAMIC RAMS

1MBIT 100ns	\$38.00
514256 100ns	\$49.00
41464 150ns	\$12.50
41256 100ns	\$13.25
41256 120ns	\$12.50
✓ 41256 150ns	\$10.95
✓ 51258 100ns	\$12.25
✓ 4164 150ns	\$ 2.95

* For high-speed, Zip, Picc, Serm Please Call!

PROCESSORS	IE PROMS
80387-16 16MHz \$415.00	27C512 200ns \$ 15.00
80287-10 10MHz \$265.00	27512 250ns \$ 12.95
80287-8 8MHz \$225.00	27C256 250ns \$ 5.50
80287-6 6MHz \$155.00	27256 250ns \$ 4.95
8087-1 10MHz \$198.00	27128A 250ns \$ 5.25
8087-2 8MHz \$142.00	27C64A 200ns \$ 4.95
8087 5MHz \$ 99.00	2784 250ns \$ 3.50
V-30 10MHz \$ 12.75	
V-20 8MHz \$ 17.00	
V-20 8MHz \$ 8.50	
	S. RAMS
	43256 120ns \$ 16.95
	4364 150ns \$ 13.50

I.C. EXPRESS

15358 Valley Blvd. City of Industry, CA 91746 Tel: 818-969-2688
ORDER TOLL FREE (Mon-Fri 8-5 PST)
(800) 892-8889 • (800) 882-8181
outside California outside California
CALL FOR CURRENT PRICES & VOLUME DISCOUNTS.
Price Shown for cash. MasterCard/VISA add 3%. Prices are subject to change.
Minimum order \$10.00. Shipping & Handling US\$ Ground \$6.00, Air \$7.00 (1 lb.)
ALL MERCHANDISE IS 100% GUARANTEED WITH PROMPT DELIVERY.

Circle 159 on Reader Service Card

9-TRACK MAG. TAPE SUBSYSTEM* FOR THE IBM PC/XT/AT AND...



For information interchange, backup and archival storage, AK Systems offers a 9-track, IBM format-compatible 1/2" magnetic tape subsystem for the IBM PC, featuring:

- IBM format 1600/3200 and 800 cpi.
- Software for PC-DOS, MS-DOS, XENIX.
- Also for AT&T, DEC, VAX, VME, S-100, RS-232, IEEE-488.

* formerly IBEX Mainstreamer
AKSystems
20741 Marilla St.
Chatsworth, CA 91311
(818) 709-6100
TWX: 910-465-2071

Write, phone or FAX for information.

Circle 14 on Reader Service Card

Add a Weather Station to your Computer.



You know how much you depend on your computer. With PC Weather Pro, your IBM PC, XT, AT or other compatible can give you the weather as well. And even keep a perpetual record. Includes hardware, software and weather instruments. Here's what you'll measure:

- Wind speed/direction
- Inside/outside temperature
- Barometric pressure
- Rainfall
- Other software options available.

Ask when you call.

ONLY **\$575** VISA/MC/AMEX accepted

TMI inc.
4000 Kruse Way Place
2-120, Lake Oswego, OR 97035
1-800-247-5712
In Oregon (503) 635-3966



Circle 338 on Reader Service Card

Tango™ Sets The Pace!

Tango's ease-of-use, rich functionality and crisp output have brought tens of thousands of boards to life, quickly and affordably.



Start-to-finish design tools include:

Tango-Schematic With Library Manager.	\$495
Tango-PCB 1 mil Grid, 9 Layers, Gerber Output.	\$495
Tango-Route Autoroutes 90+% Fast!	\$495
Tango-Tools 8 Money-Saving Utilities.	\$295

Let's discuss your design needs Toll-Free, or order a full function Evaluation Pkg. just \$10. VISA/MC.

800 433-7801 619/695-2000
Satisfaction guaranteed.

ACCEL Technologies, 7358 Trade St., San Diego, CA 92121

Circle 8 on Reader Service Card

RS-232C INTERFACE AND MONITORING EQUIPMENT CATALOG FROM B & B ELECTRONICS

WRITE OR CALL for YOUR FREE COMPREHENSIVE B & B ELECTRONICS CATALOG TODAY!



Pages and pages of photographs and illustrated, descriptive text for B&B's complete line of RS-232 converters, RS-422 converters, current loop converters, adapters, break-out boxes, data switches, data splitters, short haul modems, surge protectors, and much, much more. Most products meet FCC Part 15J.

Order direct from manufacturer TODAY... and SAVE

FREE

Your RS-232 needs for quality, service and competitive prices will be more than met by B&B ELECTRONICS. **Manufacturer to you, no middleman!** Money-back guarantee! Same-day shipment! One-year warranty on products! Technical support available.

Write For Your FREE Catalog Today!

B & B electronics
MANUFACTURING COMPANY

1502L Boyce Memorial Drive • P.O. Box 1040 • Ottawa, IL 61350
Phone: 815-434-0846

Circle 393 on Reader Service Card

What's New at AMERICAN DESIGN COMPONENTS?

"The Source" of the electro-mechanical components for the hobbyist.

We warehouse 60,000 items at American Design Components—expensive, often hard-to-find components for sale at a fraction of their original cost!

You'll find every part you need—either brand new or removed from equipment (RFE) in excellent condition. But quantities are limited. Order from this ad, or visit our retail showroom and find exactly what you need from the thousands of items on display.

OPEN MON.—SAT., 9-5

THERE'S NO RISK!
With our 90-day warranty, any purchase can be returned for any reason for full credit or refund.

12" EGA COLOR MONITOR
25 KHz — High Resolution



Perfect for text, CAD, & other graphics. 8-color display. Scanning frequency to 25KHz. Res.: 752 x 410. Input: 110/220V, 50/60Hz., 75W. Mounted in metal chassis. Works ideally w/the EGA "Wonder Card" (sold below). Diagram incl. Hitachi #CD1215-DTL

Item #18059 **\$129.00**

★ Also available in 14"
(Same specs as above.) Hitachi #CD1415-DTL
Item #18599 **\$149.00**

EGA WONDER CARD
(EGA/CGA/HGC & MDA Compatible)



Offers wide flexibility: displays all major software standards on any of the major monitor types. Incl.: connectors for EGA & RGB color monitors, TTL & composite monochrome monitors, RF modulator, PC portable, video in/out light pen & IBM feature connector. User-friendly manual; 132 column support for Lotus 1-2-3.

Item #19693 **New - \$229.00**

DYNAMIC MEMORY BOARD

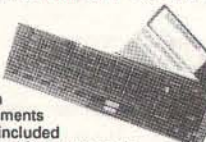

- ★ 0-256Kb memory in 64Kb increments
- ★ Software included
- ★ Fully socketed for easy upgrade (IBM parity checking)
- ★ Memdisk: simulates high-speed disk in RAM memory
- ★ Allows you to print while still using the computer

Technar #MU203010 (w/o RAM)
Item #19977 **New - \$29.95**

★ 64Kb RAM in sets of 8
Item #19983 **9 chips for \$17.50**

COMMODORE PLUS 4 COMPUTER



PLUS 4 — (Cust. Returns—Tested Good!)
Built-in software incl.: a word processor, spread sheet, graphics, & a filing system. Comes complete w/power supply & instruction manual.

Item #19202 **\$49.95**

THERMAL PRINTER
Dot Matrix—120 CPS



Print speed: 120 CPS; paper width: 8 1/2". 80/132 columns/line. With RS-232 IBM serial interface. Operates on 115/230V, 50/60Hz. Hewlett Packard #HP2671A

Item #19705 **\$79.00**
(Removed from working systems!)

5 1/4" FULL-HEIGHT HARD DISK DRIVES



40Mb (AT/XT Compat.)
High speed, 40 ms. access time. Quantum #Q540

Item #17765 **New - \$379.00**

10Mb (ST412 Compat.)
Major manufacturers — Get them while they last!

Item #17199 **\$99.00 ea.**

PC/XT/AT Compatible ENHANCED LAYOUT 101-KEY KEYBOARD



- ★ Membrane
- ★ 12 Function Keys
- ★ Separate Numerical Cursor
- ★ LED indicators for Scroll, Caps & Number locks
- ★ 1" inclination Foot Stand

Mfr. #29079
Item #19680 **New - \$49.95**

ANTI-GLARE SCREENS...



Glare & reflection filters that improve speed, accuracy & operator comfort...

IBM PC Monochrome Item #19215
IBM PC Color Item #19216
AT&T Monochrome Item #19223
Apple Macintosh Item #19225
Compaq Portable Item #19226

New - \$8.95 ea., 2/ \$15.00

Call or write with any other requirements...

STEPPING MOTORS FOR ROBOTICS...



Precision steppers with increments from 1 to 7.5° Steps up to 5,000 steps.

Item No.	Step Angle	DC Voltage	Torque oz./in.	Type	Mfr. & Part No.	Dimensions	Fig.	Price
5275	1.8°	1.8	72	PM 2Ø	Superior MO61-FF-6201B	2"L x 2 1/4" dia. x 2 1/2"H	1	\$19.95 ea. 2 for \$37.50
7630	1.8°	3.0	200	PM	Superior MO92-FT-402	2"L x 2 1/4" dia. x 2 1/2"H	1	\$34.50 ea. 2 for \$59.50
16410	1.8°	12.0	700*	PM	Applied Motion 4017-839	1 1/2"sq. x 1 1/4"D	2	\$9.95 ea. 2 for \$14.95
16406	3.6°	12.0	700*	PM	Applied Motion 4017-838	1 1/2"sq. x 1 1/4"D	2	\$9.95 ea. 2 for \$14.95
7014	7.5°	12.0	900*	PM	Mitsubishi 5S51-25DAYA	2 1/8"sq. x 1"D	3	\$10.95 ea. 2 for \$18.95

*Grams per Cm.

5 1/4" HALF-HT. HARD DISK DRIVES



10Mb (IBM® Compatible)
Mfr - NEC #D5124
Item #19704 **New - \$99.00**

20Mb (ST225 Compatable)
Mfr - Olivetti #EM5520/2
Tested-Like New!

Item #20060 **New - \$159.00**

115 CFM MUFFIN® FANS



115VAC, 60Hz., 21W., 28A., 3100 RPM, 5-blade model, aluminum housing. Can be mounted for blowing or exhaust. Dimen: 4 11/16" sq. x 1 1/2" deep

NEW - Mfr: IMC
Item #1864 **\$9.95**

USED - Mfr: Centaur/Howard
Item #5345 **\$5.95**

TTL MONITORS... HI-RES... (Open Frame)



12"-Monitor Kit Green phosphor. Input: 115VAC. Made up of sub assemblies: CRT, board, & transformer. (Hook-up diagram incl.)

Item #6811 **New - \$19.95**

15" Data Display/Monitor Kit Alpha numeric & graphics display. Green phosphor. Input power reg. 24VDC. Bandwidth: 22-72KHz. Consists of 2 subassemblies: CRT & board. (Hook-up diagram incl.) Wells Gardner #15V7025
Item #18171 **New - \$24.95**

5 1/4" FULL-HEIGHT DISK DRIVE (IBM® Compat.)



48 TPI, 40 Track, Double Side/Double Density
Tandon #TM100-2 or equiv.
Item #7928 **\$79.00 New**
2 for **\$150.00 New**

27 CFM MINI FANS



115VAC/60Hz., 12W., low noise-level fans. Can be mtd. for blowing or exhaust. Fits standard 3 1/2" relay rack. Impedance protected. 7 metal blades. Dim.: 3 1/8" sq. x 1 1/2" deep
Mfr - Rotron or equiv.
NEW - Item #13210 **\$7.95**
REE - Item #1873 **\$5.95**

SWITCHING POWER SUPPLY



DC Output: +5V @ 18A
-5V @ 2.5A
+12V @ 2.5A

Input: 115/230VAC, 50/60Hz.
Dim: 13"L x 4 1/2"W x 1 1/2"H
Mfr — Sola #39-139
Item #17210 **New - \$29.95**

... We carry a complete line of Computer & Game Accessories and Equipment!

3 1/2" MICROFLOPPY DISK DRIVE



1 Mb (unformatted), 135 TPI, 3 ms. access time. Power requirements: +12, +5 volts. Removed from operational computers — **TESTED — LIKE NEW!**
Mfr - NEC, model FD 1035
Item #17171 **\$79.00 ea.**
2 for **\$150.00**

EXTERNAL DISK DRIVE CHASSIS



With 60W power supply (fan cooled). Can accommodate:
2 full-hr. drives *our item #7928*
2 floppy drives #1904
1 hard drive & 1 floppy #13250
Input: 115/230V, 50/60 Hz.
Orig. for Burroughs computer.
Dim.: 11"W x 8"H x 12" deep

Item #14541 **\$59.50**

ADJUSTABLE POWER SUPPLY 0 - 16VDC



Input: 120VAC/60Hz., .6A. Output: variable, 0-16V, 16VDC max. @ 4.0A. UL approved; thermally protected. Has 'on/off' indicator light & front panel mtd. polarized jack. Perfect for use w/variable speed motors, fans, toys, etc.
Dim.: 6 5/8"W x 3 3/8"H x 3 1/2" deep
Mfr - Black & Decker #9321
Item #19585 **New - \$19.95**

AMERICAN DESIGN COMPONENTS, 815 FAIRVIEW AVE., P.O. BOX 220, FAIRVIEW, N.J. 07022

YES! Please send me the following items—

Item No.	How Many?	Description	Price	Total

Shipping & handling: we ship UPS unless otherwise specified. Add \$3 plus 10% of total. Canadian: \$3 plus P.O. cost. Charge only. Sales Tax (N.J. residents only, please add 6% of total)

FREE! Fall '88 Catalog with every order!

MINIMUM ORDER \$15.
Byte—1188

My check or money order is enclosed.
Charge my credit card.
 Visa Master Card Amex

Card No. _____
Exp. Date _____
Signature _____
Telephone: Area Code _____ Number _____
Name _____
Address _____
City _____
State _____ Zip _____

All inquiries and free catalog requests—call (201) 941-5000.

For all phone orders, call TOLL FREE 800-524-0809. In New Jersey call (201) 941-5000.



WE OFFER:

1. Same Day Service - All orders shipped, insured, within 24 hrs
2. Guaranteed Satisfaction - Lifetime warranty, 30-day return guarantee
3. In-stock Inventory - No delays, no disappointments
4. No Minimum Order - Quantity discounts also available
5. Pre-Approved Purchase Orders and Visa & MasterCard Accepted

AND GREAT PRICES!

- 5.25 Black Disks, DS/DD36 ea.
- 5.25 Color Disks, 8 Colors Available, DS/DD46 ea.
- 5.25 Black Disks, DS/HD82 ea.
- 5.25 Color Disks, 8 Colors Available, DS/HD94 ea.
- 3.5 Blue or Gray Disks, DS/DD1.12 ea.
- 3.5 Color Disks, 5 Colors Available, DS/DD1.28 ea.
- 3.5 High Density, Black only3.80 ea.

100% certified and tested. Error free lifetime warranty. All disks include generic white box, Tyvek sleeves, labels, write protect tabs, shrink wrapped.



CONTINUOUS FORM LABELS

Size	Across	Box Qty.	Price/1,000
2 3/4 x 7/16	1 across	10,000	\$1.95
2 3/4 x 7/16	4 across	20,000	\$1.95
2 1/2 x 15/16	1 across	5,000	\$2.18
2 1/2 x 15/16	3 across	15,000	\$1.98
2 3/4 x 2 3/4*	1 across	2,500	\$12.00
2 3/4 x 1-7/16	1 across	5,000	\$3.00
3 x 15/16	4 across	20,000	\$2.00
3 3 x 15/16	4 across	20,000	\$2.05
3 1/2 x 15/16	1 across	5,000	\$1.90
3 1/2 x 15/16	2 across	10,000	\$1.90
3 1/2 x 15/16	3 across	15,000	\$1.90
3 1/2 x 15/16	4 across	20,000	\$1.90
4 x 15/16	1 across	5,000	\$3.21
4 x 15/16	3 across	15,000	\$3.21
4 x 1-7/16	1 across	5,000	\$3.25
4 x 1-7/16	3 across	15,000	\$3.25

Prices quoted for full boxes only. * Designed for the 3 1/2" disk.

"The Quality Disk & Label Specialist Since 1982"
 1040 Broadway
 Westville, NJ 08093
609-456-6996
FAX# 609-456-7172
 All products assembled in the U.S.A.
 All orders F.O.B. Westville, NJ
 C.O.D. orders add \$2.20

Communications Analyzer



- Monitors and stores to disk RS232 async data in real time
- Dual line DCE over DTE format
- Perform action on any data pattern
- Interactive mode
- Fully configurable, includes cables
- For IBM/PC/XT/AT or compatibles



Palladian Technologies Incorporated \$395.00 demo \$10

1-800-537-5046 (301)576-0575

Circle 395 on Reader Service Card



Complete units as low as **\$35.**/mo.



XT, AT, & 386 Compatibles
 Not a Lease—You own it

- ★ 2,500 Service Centers!
- ★ Instant Credit!
- ★ Technical Support!

Call for Details
1-800-825-SAVE

Circle 25 on Reader Service Card

SAVE ON 9 TRACK TAPE SYSTEM



- Mainframe to PC Data Transfer
- High Speed Backup
- All Software, Complete System
- Service and Support, easy Installation

call (818) 343-6505 or write to:
CONTECH Computer Corp.
 P.O. Box 153 Tarzana, Calif. 91356

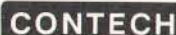

Circle 81 on Reader Service Card

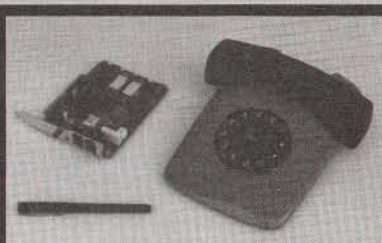

2400 BAUD \$95 MODEM

30 DAY FREE TRIAL

SUPERIOR PERFORMANCE . . . NOT ERRORS AND NOISE. WE CAN PROVE IT. NO COMPROMISE 2400, 1200, 300 BAUD MODEM. FULL FEATURED, HAYES COMPATIBLE IBM INTERNAL. • SOFTWARE INCLUDED • DEALERS INQUIRE • 30 DAY MONEY BACK TRIAL. CALL FOR DETAILS

CompuCom Corporation
 (800) ACT ON IT (408) 732-4500

Circle 72 on Reader Service Card

VOICE IN A BOX \$80.00 each Or as low as \$30.00 in OEM quantity



VOICE ON AN EPROM is really an exciting product. Now you can put your voice or special sound effect in a box smaller than a cigarette package. Yes, it is **Voice in a Box**. More precisely, you store your voice on an Eprom or Rom chip, and plug in the chip on our Voice Playback Board (VPB). That is it! You can now instantly playback the high quality digitized voice again and again.

Applications: There are thousands of them in use now for promotional voice messages. It is ideal for voice announcement, advertisement, sound effects, voice instructions, and security. For us, we record our child's voice on a chip and have it ready anytime we like to hear the sweet "mama". We call it a "Voice-Photo". Take a picture of your loved one's voice and the sound memory is there for you to recall. We even have people talking about putting their will on the chip!

The Voice Playback Board (VPB) is for playback of the voice on a chip. To record and program the voice you need the following on an IBM PC XT/AT Compatible System:
 Voice Development Software (VDS)\$156.00
 Digital Voice Card (DVC) for PC . . . \$35.00
 *Includes Speaker and voice processor.
 Microphone (\$20 impedance) . . . \$12.00
 Speaker (4 c. 1W with enclosure) . . . \$9.00
 The VDS development software allows you to record, playback your digitized voice on a PC XT/AT, and compatible. It also allows you to merge up to 16 voice segments to a voice data file. The data file can then be programmed into an Eprom chip using commercial available PC based Eprom Programmers.
CALL (416) 859-0370 TO ORDER FROM THE U.S. 1-800-263-7487
COMPUTER AGE LTD.
 P.O. BOX 730
 NOBLETON, ONT. L0G 1N0
 FAX 1-(416) 859-0772

Circle 76 on Reader Service Card

TurboFlow \$69

Flowchart drawing for IBM PC/XT/AT/PS2

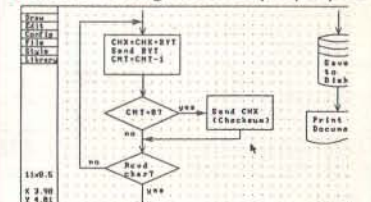

\$89 with Logitech mouse!

- Pop-up icon menus
- Variable size symbols
- Paper size to 34" x 44"
- Hercules mono, CGA, EGA
- HP-GL, DM/PL, SweetP Plotters
- Automatic PANning to scan drawing quickly
- IBM/EPSON, NEC, OKIDATA, HP LaserJet



Daytron Electronics Inc.
 610 S. sherman #104, Richardson, Tx 75081
 Add s&h (\$4 USA, \$20 foreign), Texas residents add 8% sales tax

Order Today! 1-214-669-2137

Money-back guarantee

Circle 93 on Reader Service Card

LOWEST PRICES FROM NEVADA'S LARGEST SINGLE COMPUTER OUTLET

CAT™ 8MHZ BASE SYSTEM

- 256K (Opt. 640K) • 150 Watt Power Supply • AT Style Keyboard
- 4.77 or 8 MHz Keyboard Selectable • FDC
- 8087 Socket • 360K Floppy Drive

\$39900



10MHZ ADD \$2500

COMPLETE SYSTEM CALL FOR PRICE
1 Year Warranty



CAT™ 286-10 BASE SYSTEM

- 512K Exp. to 1 MEG • 200 Watt Power Supply • AT Style Keyboard
- Western Digital Controller • 1.2 Meg Floppy • Legal Bios w/manuals • Systems Documentation • 1 yr war. • Clock/Calc

\$92900



386 SYSTEM CALL

COMPLETE SYSTEM CALL FOR PRICE
11.3 Nortons SI

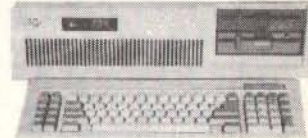

OPTION A
12" Mono Amber Monitor
Graphics Card w/par port

\$54600

OPTION B
640 x 200 Color Monitor
Graphics Card w/par port

\$71600

OPTION C
12" Mono Amber Monitor
Graphics Card w/par port
20 Meg Hard Drive

\$81900

OPTION A AT
12" Mono Amber Monitor
Graphics Card w/par port

\$107600

OPTION B AT
640 x 200 Color Monitor
Graphics Card w/par port

\$129900

OPTION C AT
12" Mono Amber Monitor
Graphics Card w/par port
20 Meg Hard Drive

\$139900

CALL (800) 654-7762 FIRST FOR GUARANTEED LOWEST PRICE

PRINTERS BY

6FT PARALLEL CABLE 1400

EPSON		
LX800	199	LQ 500 339
LX86E	329	LQ850 529
LX286E	429	LQ1050 749
EX800	439	FX850 349
LQ2500	839	FX1050 499

Panasonic

KXP1080I 144CPS	199	180D 180CPS 9 Pin 10" 179
KXP1091I 192CPS	229	MSP15E 160CPS 9 Pin 15" 369
KXP1092I 240CPS	379	MSP40 250CPS 9 Pin 10" 369

CITIZEN

Tractors — Sheet Feeders — Cables — Ribbons Available

VIDEO CARDS

Vega VIDEO SEVEN	17900
Everex EGA 640 x 350	12900
Vega VGA PS2 Compatible	34900
Everex VGA 640 x 400, 17 VGA Modes	24900
Everex PGA 640 x 480, 256/4096 Colors	62900
MEAD Monographics w/par port Hercules comp.	5800
MEAD Color graphics w/par port Hercules comp.	5800

ODD'S & END'S FROM MEAD

150 Watt Power Supply Direct PC Replacement	5400
200 Watt Power Supply Direct AT Replacement	7900
Dos 3.2 w/GW Basic	6900
Everex Ram Expansion for AT or XT starting at	5900

Seagate HARD DRIVES

1 YEAR WARRANTY
SETUP INSTRUCTIONS

COMPLETE KITS

ST125 20Meg 40 Mil 1/2 Ht	29900
ST225 20Meg w/cont. & Cables	26900
ST238 30Meg w/cont. & Cables	29900
ST251 40Meg 1/2 HT 40 Mil w/software	37900
ST251-1 40Meg, 28 Mil Sec	47900
ST277R 60MB 40 Mil 1/2 Ht	48900
ST4026 20Meg Full Ht 40 Mil	27900
ST4038 30Meg 40 Mil Full Ht	29900
ST4053 40MB 28 Mil Full Ht	51900
ST4096 80Meg Full HT w/software	64900

MODEMS BY EVEREX™

EV-920 EverCom 12 300/1200 bps Bitcom Software	7400
EV-940 EverCom 24 2400 Baud Int. Bitcom Software	13900
EV-945 External 2400 Baud	19900

For error correcting add \$10.00

Hayes Compatible Major Manufacturers

1200 Baud Internal w/Software	6900
1200 Baud External fully Hayes Compatible	9900
2400 Baud Internal 1/2 card w/software	12900
2400 Baud External Fully Hayes Compatible	12900

TAPE BACKUPS BY EVEREX™

40MB Mini Cartridge, 1.8MB/min, XT	35900
40MB Mini Cartridge, 3.6MB/min, AT	35900
40MB Streaming Cassette, 5MB/min w/cont.	53900
60MB Streaming Cassette, 5MB/min w/cont.	61900
60MB Streaming Cartridge, 5MB/min w/Full cont.	77900
125MB Streaming Cartridge, 5MB/min w/Full cont.	98900

External Add 19500

CONTROLLERS BY WESTERN DIGITAL

WX-1 8 Bit 1/2 Sized for XT	6900
WA-2 16 Bit Full Sized Hard/Floppy	11900
WD-27X 8 Bit RLL 1/2 Size	7900
WAH 16 Bit Hard Drive Controller	ONLY 12900
RA2 16 Bit RLL Hard/Floppy for AT	15900
MEAD Floppy Disk Controller for XT	2900
MEAD 1.2 Meg & 360K Controller for XT Hard/Floppy Cable Set	5900

MONITORS BY SAMSUNG

1252 12" Amber w/Tilt & Swivel Base	7900
1257 12" Amber Flat Screen 720 x 350	8900
1464 14" Color 640 x 200, 16 colors	23900
1453 14" EGA 640 x 350, 64 colors/31	36900
CN4551 Multisync EGA 720x480	43900

IBM CGA/VGA/PGA/EGA Compatible

FLOPPY DRIVES FROM YOUR LOW PRICE LEADER

360K 1/2 Ht. PC Compatible	6900
1.2 Meg Mitsubishi Black Face	7900
720K 3/2" Epson Drive w/5/4" mounting	8900
1.44 Meg 3/2" Drive w/5/4" mounting	11900
360K Tandon TM100-2 Full Ht.	8900
160K Tandon TM100-1 Full Ht.	3900

COPROCESSORS BY intel

LARGE QUANTITIES AVAILABLE

Intel 8087 5Mhz	9900
Intel 8087 8Mhz	13900
Intel 80287 6Mhz	17900
Intel 80287 8Mhz	23900
Intel 80287 10Mhz	27900
Intel 80387 16Mhz	39900
Intel 80387 20Mhz	69900

ALL ITEMS BELOW ARE REDUCED BELOW DEALERS COST*

LETTER QUALITY PRINTER

DAISYWHEEL PRINTER MANUFACTURED BY C.ITOH

Why pay \$1149 for a C.Itoh
STARWRITER™ F-10

When our 40 cps letter quality daisywheel printer from the same manufacturer is only

\$29900 ea. 100 for \$249 ea.

- #### OPTIONS
- 6 ft. Serial Cable \$ 1900
 - AT or XT RS232/Serial Interface 3900
 - Bidirectional Tractor 14900
 - Cut Sheet Feeder 19900

- #### STANDARD FEATURES
- 40 CPS • Accepts Paper to 15 inches • Form Length and Pitch Set from Control Panel
 - Industry compatible ribbon, printwheels and control commands • RS232 Serial Interface

RAM UPGRADES

1 YR. WARRANTY

4164 150 NS 295	41256 100 NS 1275	Simm Sipp Zipp
4164 120 NS 325	41256 80 NS 1375	256 x 9 100 NS 12900
4164 100 NS 345	4464 150 NS 1595	256 x 9 120 NS 11900
41256 150 NS 1145	1Meg x 1 120 NS 3700	1Meg x 8 120NS 44900
41256 120 NS 1175	1Meg x 1 100 NS 3900	1Meg x 9 120NS 49900

60 MEG TAPE BACKUP

- Wang Tec 60 Meg Drive
- Controller & Software

List 1195 Mead 499

AT BARE SYSTEM

- 10 MHz, 0 Wait State Mother Board
- AT Case and 200 Watt Power Supply
- 101 Enhanced Keyboard

List 799 Mead 429

10 MEG HARD DISK KIT

Includes Controller & Cables

- 1/2 Height • 80 Msec
- Brand New/Major Manufacturer

Mead 15900

40 MEG HARD DISK AT COMPATIBLE

- Full Height • 40 Msec
- 30 Day Warranty

Mead 27900 10 for 24900 ea

AT CASE

- 2 Bay Standard AT Style Case
- Keylock Power and Hard Drive LED's

List 99 Mead 3900

TAPE CASSETTE/CARTRIDGE

DC1000, 3M 900	DC300A Used 700
DC300XCP 45Meg 1400	CS600 2400
CS500 1900	

800-654-7762

SALES: 7 a.m.-6 p.m. PST

702-294-0204

CUSTOMER SERVICE / ORDER STATUS:
9 a.m.-4 p.m. PST

FAX 702-294-1168



NO SURCHARGE FOR MC/VISA

TERMS:

MC • VISA • COD • CASH
Purchase Orders from Qualified Firms
Personal Checks • AE add 4%

20% Restocking Fee on Non-Defective Returns



Trademarks are Registered with their respective Co.'s. Prices Subject to Change
*RAM not include. All are new, 90 Day warranties.

1000 Nevada Hwy. • Unit 101 • Boulder City, NV 89005

SHIPPING: (min. 6⁰⁰) UPS

3M *FREE! DataSaver ...
a \$13.95 diskette filler!!



DS-DD	Quantity Discounts Available	DS-HD
.69	5.25" 3M Diskettes ...	*1.45
1.49	3.50" 3M Diskettes ...	3.99
1.99	8.00" 3M Diskettes ...	2.25
.85*	3M Mark Q PC "Formatted" Disks	
.47	3M Highland Box Diskettes	
.52	3M No Logo Bulk, w/tyvek, labels w/p	
DC-1000	12.65	DC-300XLP 19.45
DC-2000	17.05	DC-600A 21.45
3M Mag. Tapes 2400' W-T-S		12.50
3M Mag. Tapes 1200' W-T-S		9.25
14.95	Data Defender 050 for 50 - 3 1/2"	Data Defender 070 for 70 - 5 1/4" w/keys 14.95

BASF *FREE Plastic Library Box



DS-DD	Quantity Discounts Available	DS-HD
.59*	5.25" BASF Diskettes ...	*.89
1.34	3.50" BASF Diskettes ...	3.79
1.79	8.00" BASF Diskettes ...	1.99

COLOR-CODED MODULAR FILING CASE FREE WITH EACH PURCHASE OF 25 BASF 3.50" Diskettes!

BASF Mag. Tapes 2400' W-T-S 11.95
 BASF Mag. Tapes 1200' W-T-S 7.99
 BASF No-Logo 5.25" DS/DD42

maxell

MD2-DMP	MD2-HDMP	MF2-DDM
5.25" DS/DD	5.25" DS/HD	3.50" DS/DD
.69*	1.49*	1.69

*IN PLASTIC BOX

Verbatim DataLife

5.25" DS/DD	5.25" DS/HD	3.50" DS/DD
.69*	1.29*	1.49

*FREE DataLifePlus Offer Inside

COLOR DISKS

5.25" DS/DD	3.50" DS/DD	3.50" DS/HD
.69*	1.59*	3.49

*IN PLASTIC BOX 2MB

3M

5.25" DS/DD	5.25" DS/HD	3.50" DS/DD
.69	1.49	1.69

Nashua

5.25" DS/DD	5.25" DS/HD	3.50" DS/DD
.46	.82	1.29

BULK Box of TEN 5.25" DS/DD with sleeves, labels and w/p tabs **3.35**

Black Disks	Color Disks
.29	5.25" DS/HD/48 TPI39
.69	5.25" DS/HD "AT"79
1.11	3.50" DS/HD/135 TPI ... 1.25

FREE SLEEVES, LABELS AND W/P TABS

RIBBONS STORAGE
—Please call for information—

TERMS: VISA, Mastercard or AMEX. COD only add \$3.00. Prepaid orders deduct 2% cash discount. PO's accepted from recognized institutions and corporations on Net 30. Bank draft, T/T or L/C acceptable. **Shipping:** \$4/100 or fewer disks. Reduced shipping charges on larger quantities. Price quoted for case (100 disks) quantities less than a case add 5%.

WE BEAT ANY PRICE!
Toll Free Order Line: **1-800-523-9681**
Information Line: **1-801-255-0080**
TLX-9102404712 FAX-801-572-3327

DISKOTECH
DISKCO TECHNOLOGIES, INC.
213 Cottage Avenue
P.O. Box 1339 Sandy, Utah 84091

PAL/EPROM PROGRAMMER for PC
VERSION 2 of Software and Hardware \$475

- Programs 20 and 24 pin MMIL, NS, TI, Altera, Cypress, Ricol/Parasac PALs, EPFL (UV erasable), polarity, and RA types.
- Functions Include: read, write, verify, protect, edit, print, and file load and save of program.
- JEDEC files supported.
- 2716-27312 EPROMs.
- Functions Include: read, write, verify, blank check, HI/LO split, edit in ASCII, HEX, or Decimal.
- INTEL Hex and Motorola 'S' Record file support.



200/100 MHz LOGIC ANALYZER for PC

LA27100	\$1299
LA27200	\$1899

- 24 Channel mode with 4K/channel • 6 Channel mode with 16K/channel
- Internal Rates from 200MHz(LA27200) or 100MHz(LA27100) to 250 Hz
- External Clock from DC to 50 MHz • 16 Level Triggering Sequence
- Threshold Voltage Level at TTL, ECL, or -8V to +14V variable • Data Display as Timing Diagram or State List • Save/Load Data and Setup Info.

(201) 994-6669
Link Computer Graphics, Inc.
4 Sparrow Dr., Livingston, NJ 07039



Circle 188 on Reader Service Card

Dynamic Electronics

23552 Commerce Center Dr. Suite L. Laguna Hills CA 92653

Stocking Distributor of Semiconductors

8087 • 5 • 8 • 10
80287 • 6 • 8 • 10 MEG
80387 • 16 • 20 MEG
256K • 64K • 128K • V20 • V30

Fast • Reliable • Everytime

Phone: 714-855-0411
Fax: 714-855-8504

No refund - exchange only - Exchange good for 30 days unless manufacturer warranties merchandise longer

Circle 115 on Reader Service Card (DEALERS: 116)

DATA ACQUISITION TO GO
INTERFACE FOR ANY COMPUTER
FREE IBM SOFTWARE



Connects via RS-232. Fully IBM compatible. Built-in BASIC. Stand alone capability. Expandable. Battery Option. Basic system: 16 ch. 12 bit A/D, 2 ch. D/A, 32 bit Digital I/O. Expansion boards available. Direct Bus units for many computers.

(201) 299-1615
P.O. Box 246, Morris Plains, NJ 07950

ELEXOR

Circle 120 on Reader Service Card

Precision Data Products™
P.O. Box 8367, Grand Rapids, MI 49518
MI: 800-632-2468
616-452-3457 FAX: 616-452-4914

3.5" Diskettes

HD 2.0 Megabyte \$2.95 ea.
DD 1.0 Megabyte 95¢ ea.

Fully Certified - Lifetime Warranty
Minimum 50 Diskettes

5.25" Diskettes

DSDD 29¢ ea.
FREE Envelopes & W/Tabs
Minimum 100 Diskettes

FOREIGN ORDERS INVITED
FREE CATALOG

Complete line of quality supplies for your computer.

S&H: (USA) \$4.00 first 100 or fewer disks, \$3.00 each succeeding 100 or fewer. Prices Subject to Change.

Toll Free: 800-258-0028



Circle 257 on Reader Service Card

Why waste time?
ACCELERATE with VCACHE™

HARD DISK ACCELERATOR

- Caching eliminates repetitive disk accesses
- Use up to 15 Mb of extended/expanded or 500 Kb of standard memory

DISKETTE ACCELERATOR
SCREEN ACCELERATOR

FAST - FRIENDLY - SAFE

VCACHE
GOLDEN BOW SYSTEMS

\$59.95
Add \$3 for shipping/handling California residents add 6% sales tax

2870 Fifth Avenue Suite 201 San Diego, CA 92103
800/284-3269



Circle 143 on Reader Service Card

! not only a printer buffer!

THIS IS THE MOST SOPHISTICATED
PRINTER BUFFER - MULTIPLEXOR - SWITCH

WITH TWO SEPARATE INPUTS (SERIAL AND PARALLEL) AND TWO SEPARATE OUTPUTS (SERIAL AND PARALLEL) CAN BE USED LIKE STANDARD BUFFER... WITH ANY INPUT TO ANY OUTPUT... BUT ALSO YOU CAN CONNECT 2 COMPUTERS TO 1 PRINTER OR 1 COMPUTER TO 2 PRINTERS OR 2 COMPUTERS AND 2 PRINTERS... AND MORE = 1 COMPUTER TO 3 PRINTERS OR 3 COMPUTERS TO 1 PRINTER

HIGH CAPACITY - 64 KB TO 256 KB AND - 256 KB TO 1 MB (MODELS A AND B) PAUSE, COPY AND RESET FUNCTIONS SERIAL PORTS WITH 1 OR A BIT WORD LENGTH, 1 OR 2 STOP BIT, PARITY, XON/XOFF, DTR, RTS.

DOB-A-64K \$ 195 DOB-B-256K \$ 255 (**)

(**) Power supply and parallel cables are included.

ALSO, WE HAVE THE MOST COMPLETE DATA CONVERTER UNIT CONVERTS RS232 SERIAL TO CENTRONICS PARALLEL OR VICE VERSA, JUST BY MOVING JUMPERS BAUD RATE AND PROTOCOL FULLY PROGRAMMABLE FROM 150 TO 19200 BAUDS INCLUDES: DTR, RTS, XON/XOFF, PARITY, etc

DCU \$ 80 (***)

(***) Power supply and cables NOT included

serial \leftrightarrow parallel bi-directional converter

INTECTRA Inc. - Dept. 232
2029 TERMINAL BLVD MOUNTAIN VIEW-CA-94043
(415) 967-8818 TX 345545



Circle 120 on Reader Service Card

TIMELINE INC.

ORDER DESK ONLY

Continental U.S.A.
(800) 872-8878

Inside California
(800) 223-9977

L.A. & Technical Info
(213) 217-8912

OEM INQUIRIES
WELCOME

SUPER SELL-A-THON

**8 MHz AT MOTHERBOARD-
512K MEMORY ON BOARD \$329.00**
8 SLOT (2 Eight bit, 6 Sixteen bit)
-Battery backed clock-Sockets for 1 Mb of RAM and 80287-WOW!
-1 Wait state-Hardware Selection of 6 or 8 MHz-Keylock sup-
ported, Reset switch, Front panel LED Indicator-BIOS included.

2/3 HEIGHT FLOPPY DISK DRIVE \$24.00!
-360K - DS/DD - REMEX RFD480
(Faceplate to make full Height:\$4.00)

1.2 Mb FLOPPY DRIVE FOR AT \$49.00
1/2 Height - Reads/Writes 360K disks

FLOPPY DISK DRIVE \$19.00
SEIKO 8640 FULL HEIGHT- 640K-
These drives are NEW and sold AS IS. 400 in stock. May require special software or other technical assistance to make them work. We have no manual or technical assistance for this product.

40 Mb HARD DRIVE \$225.00
Full Height QUANTUM 540 - 51 ms access time

CDI 12" GREEN MONITOR \$39.00
NON-ENCLOSED - HIGH RESOLUTION - TTL
-Horizontal sync: 15 to 32 KHz
-Vertical sync: 47 to 63 Hz (80 Hz optional)
-Vertical Performance: 1200 line center resolution
-35 MHz within 3db bandwidth

CONRAC 19" COLOR MONITOR \$1,200.00
7211C19 (Originally \$4600) Bandwidth: 100 Hz to 40 MHz
-Resolution: 1080x809
-Scan Rate: 15,750 to 36,750 lines/sec interlaced or non-interlaced
-High and Low input impedance

3 Megabyte Floppy Drives \$25
(Amlyn or Kodak Mfg.)-Runs with AT type or 8" HD Controller-
-KODAK has 160 tracks, 17 sectors per track. AMLYN has 154 tracks, 15 or 16 sectors per track. It is 2.35 or 2.6 Mb formatted. Can read 360K disks. Requires 50 pin, 8" cable.) -Standard 34 pin floppy drive interface - Controllers available for XT or AT add on to 4 floppy drvs.
-Program and file compatible, requires driver software. (505) 579-4496
Technical Assistance
KIT \$129.00 DRIVE, CONTROLLER, SOFTWARE, 1 MEDIA DISK

ROBOTIC LENS \$19.00
Great source of optical and electro-mechanical parts and systems including the basis for an infrared communications system.
Contains f1.4 - 12 to 72 mm (8x) zoom lens with auto focusing capability. DC motor driven or manual zoom and focus systems with precision gear reduction units, mechanical clutches, and high quality DC motors. DC rotary actuator controlled iris diaphragm unit.
Option Available: Infrared distance measuring system (focusing unit) with control electronics \$10.00.

TAPE BACKUP CARTRIDGES--
DC300 XIDEX \$10.00
(2 pc. minimum)
DC1000 No label \$5.00
(4 pc. minimum)

FULCRUM TRACK BALL \$89
• Stationary Mouse
• PC Magazine Editors
First Choice for CAD Use
New Menu Key
-Do Lotus 123
Wordperfect or your own menus

EPSON QX-10 MOTHERBOARD \$59.95
w/your choice: ASCII Keyboard (Enclosed) or MASCII (para)
Will work with any IBM compatible disk drive + CPU: XT/286/386/486 compatible, 4 MHz + Memory-RAM: 256K on board. C-MOS RAM: 2K. EPROM: 2/4/8K (for IPL) Clock: C-MOS real-time clock. Interface: Serial and Parallel. DMA: 7 channels. Interrupt levels: 15; Counter/timer: 6 channels. Card slots: 5. Compatible with any TTL monitor. Weight: 10 lbs. with enclosed keyboard, 8 lbs. with bare keyboard.

ADAPTEC 4000A SCSI Controller \$60.00
I/O for the ST412-506 Interface using MFM encoding

ZENITH 7" MONITOR \$29.95
Model DJ7/NK2
HIGH RESOLUTION AMBER
• Flat faceplate
• 900 lines at center
• 650 lines at corners
• Operates from 12VDC at T.4 amp
• Vertical input is 47 to 63 Hz
• Horizontal frequency: 15 KHz (adjustable)
• 22 MHz TYPICAL BANDWIDTH
For split video (TTL inputs) operation. Not composite video.
4 for \$99

POWER SUPPLY YOUR CHOICE! BLOWOUT! \$12.00
Minimum 2 per Order

Please check dimensions. These are open frame supplies.

188 Watt Switching Power Supply.

On/off switch in the front. Built in filter for easy power cord plug-in. Open frame, L-bracket type. Two 4-pin power plugs for floppy and/or hard disk drives.

Output: +5.05V @ 22A, +12.02V @ 4A, -12V @ .5A, +12.59 Reg. @ 1.5A D.C.

Dimensions: 13 1/2 L X 5 1/2 W X 2 3/4 H

Compower 130 Watt supply. Unit is open framed.

Output: +5V @ 5A, +12V @ 5A, -12V @ .5A
Dimensions: 8 1/2 L x 4 1/4 W x 2 1/2 H

Power Systems - 180 Watt supply. Unit is open framed with 2 four pin power connectors built onto the unit.

Output: +5V @ 20A, +12V @ 4A, -12V @ 5A
Dimensions: 9 1/2 L x 4 1/4 W x 2 1/2 H

THE RETURN OF THE SPY IN THE SKY
NEC UPD791D - (CHARGE COUPLED DEVICE) 4096 ELEMENT - LINEAR IMAGE SENSOR

The charge coupled device is soldered to a pre-amplifier board. (We sold out of the A/D board that accompanied the unit... They went fast!) Since this is an analog device, the circuitry to provide timing signals and convert analog outputs to digital MUST BE SUPPLIED BY THE PURCHASER to interface to a microprocessor based system.

Timing requirements could be determined from a NEC manual on the 791D or from the schematic on the A/D board. PLEASE NOTE: We have the A/D board schematic, but unfortunately, we do NOT have the NEC manual. Designed for page scanning applications including facsimile, (Optical character recognition and other imaging applications which require high resolution and high sensitivity)

NEC 5261 LASER TUBE \$99.00
(Same as 5260) 10 Milliwatt (Max Output)-5 Mw (minimum)

Tube is in cylindrical housing 15" long. Emits Red beam. -Class IIIb Laser-Random Polarization-Non-polarized Laser-Mode: TEM₀₀-Beam diam. at 1/e².83mm-Beam divergence: .96mrad-Operating Voltage: 2350V±100-Starting Voltage: <10KV-Operating Current: 6.5 mA

VGA Color Graphics Package

Possible Display Modes VGA Graphics:
800x560x16 colors 320x200x256 colors
640 x 480 x 16 colors 640 x 350 x 16 colors
640 x 200 x 16 colors 640 x 200 black and white
320 x 200 x 4 colors: 40 and 80 column character mode

The manufacturer of this monitor SET THE STANDARD FOR COLOR GRAPHICS. The card is an ATI improved VIP CARD. The package comes with user friendly manual and step-by-step instructions. One year warranty on the monitor. Two year warranty on the card.

\$649.00 UPDATE YOUR XT/ AT TO VGA GRAPHICS
Call for Qty. Discounts

Herules Graphics Compatible
• Max resolution (800x560)
• Bandwidth: 17 Mhz
• Software selectable to VGA, EGA, CGA, MDA, HGA
• Anti-reflective, coated non-interface flicker free screen .31 dot pitch

Minimum Order: \$20.00. Shipping & handling charges via UPS Ground: \$.50/lb. UPS Air: \$1.00/lb. Minimum Charge: \$4.00. We accept cashiers checks, MC or VISA. No personal check COD's. California residents add 6 1/2% sales tax. We are not responsible for typographical errors. All merchandise subject to prior sale. Phone orders welcome. Foreign Orders require special handling. Prices subject to change without notice.



1490 W. ARTESIA BLVD, GARDENA, CA 90247
Order Desk Only OEM Inquiries Welcome
Inside California Continental U.S.A. L.A. Area & Technical Info.
(800) 223-9977 (800) 872-8878 (213) 217-8912
15% Restocking fee for returned orders.



DEVICE PROGRAMMER
\$550 \$750



1 Megabit of DRAM, User upgradable to 32 Megabit 4x20 LCD Display, 3, 6 Zif socket, RS232, PARALLEL in and out 20 Key tactile keypad (not membrane). 32K internal EEPROM (easy firmware upgrades) QUICK PULSE ALGORITHM (27256 in 5 sec. 1 Megabit in 17 sec.) Completely stand alone, 10 day money back guarantee 2 year warranty, made in U.S.A. Technical support by phone, Complete manual and schematic.

NEEDHAM'S ELECTRONICS

4535 Orange Grove Ave., Sacramento, CA 95841
Call for more information
Phone (916) 924-8037 FAX (916) 972-9960
VISA/MC

Circle 236 on Reader Service Card

CHIP SHOP

**CALL FOR THE
LOWEST PRICES**

SAME DAY SHIPMENT

4164 8087
4128 80287
41256 80387
1 meg chips
V20, V30 and more

SABINA INTERNATIONAL, INC.

657 Brea Canyon Road, Suite 4, Walnut, CA 91789
Phone 1-800-2 SABINA
Phone 1-714-594-6336
FAX 714-595-4008

Circle 289 on Reader Service Card



The Bible Library™

29 titles: 9 bibles + 20 reference works on one CD-ROM laser disc. The most comprehensive Bible study tool available for the minister and layman..... \$495

CD-ROM/WORM OUTLET
Save While Supplies Last

AMDEK DRIVE \$639
HITACHI DRIVES 2 for 1 Sale
MS DOS & MAC SAV DISCOUNTED: Groliers, McGraw-Hill Science, Supermap, U.S. Atlas Geovision, Comstock — 449 photos, PC-SIG (25,000 programs), Public Domain — Alde (5,000 arced programs).

CALL 1-800-543-1734 ANYTIME

(716) 852-6711 One Day Service
C.O.D./AMEX/MC/VISA
JASON ENTERPRISE
Dept. D, 5459 Main Street
Williamsville, NY 14221

Circle 172 on Reader Service Card

THE ONLY SOURCE YOU'LL EVER NEED!

FAST 286

- 16 BIT CPU-80286-12 AMD (N80L286-12)
- FIVE 16 BIT SLOTS, THREE 8 BIT SLOTS
- 512K RAM, EXPANDABLE TO 4MEG ON BOARD
- EMS COMPATIBLE W/SOFTWARE
- LANDMARK SPEED TEST 16.1, NORTON ADVANCED SI 13.7
- AT SLIDE CASE W/POWER AND TURBO INDICATORS
- KEYBOARD LOCK
- 200 WATT POWER SUPPLY

- AWARD BIOS W/SETUP IN BIOS
- 1.2 MEG FLOPPY DRIVE
- HARD/FLOPPY CONTROLLER
- 101 ENHANCED KEYBOARD

BASE SYSTEM
\$959

- MONOCHROME SYSTEM \$1,089
- COLOR SYSTEM \$1,269
- EGA SYSTEM \$1,509

VERTICAL 386

- 32 BIT CPU-80386-16
- CPU SPEED 16MHz 0 WAIT STATE
- TWO 32 BIT SLOTS, FOUR 16BIT, TWO 8 BIT
- 1 MEG RAM, EXPANDABLE TO 4 MEG
- LANDMARK SPEED TEST 19.1
- VERTICAL CASE W/SPEED INDICATOR, POWER AND TURBO LEDS
- KEYBOARD LOCK
- 200 WATT POWER SUPPLY SWITCHABLE
- PHOENIX BIOS W/SETUP IN BIOS
- 1.2 MEG FLOPPY DRIVE
- HARD/FLOPPY CONTROLLER
- 101 ENHANCED KEYBOARD

- MONOCHROME SYSTEM \$2,419
- COLOR SYSTEM \$2,590
- EGA SYSTEM \$2,839

BASE SYSTEM
\$2,280



COMTRAD™
INTERNATIONAL CORP.

6306 NW 77CT., MIAMI, FLORIDA 33166

Free UPS GROUND SHIPPING IN THE CONTINENTAL USA

CALL FOR DETAILS (305) 593-2009 FAX (305) 477-8607

8051 SIMULATOR

for the IBM PC/XT/AT **\$99**

The 8051SIM software package assists in the debug of 8051 family programs. A screen oriented, menu command driven program, 8051SIM simulates the Intel 8051 family of single chip microcomputers. This learning tool also speeds up the development process.

8031 DryICE \$199

The 8051 Dry ICE is a hardware/software package that allows you to dump and modify memory; execute and trace 8051 family code in your target system. Hardware connects between target system and any serial port.

HTE HiTech Equipment Corporation
9560 Black Mountain Road
San Diego, CA 92126
(619) 566-1892

Circle 154 on Reader Service Card

Bullet Modem



- Turbo 2400 bps + MNP™ Class 5
Up to 7200 bps internal \$295
..... external \$395
- Up to 19,200 bps \$1,195
- 100% Error Free Data
- PSTN & Leased Lines, AT Command

E-Tech Research
3333 Bowers Avenue, # 165
Santa Clara, CA 95054
(408) 982-0270, FAX (408) 982-0272
Leader in High Performance Modems

Circle 128 on Reader Service Card

Statistical Software for OS/2 ?

Of course

General Statistical Analysis
Forecasting and Modeling
Quality Improvement

To find out more contact:

Scientific Computing Associates



Lincoln Center, Suite 106
4513 Lincoln Avenue
Liste, Illinois 60532

Telephone: 312-960-1698

Circle 295 on Reader Service Card

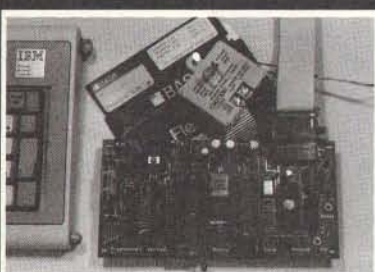

6805/6305 SINGLE CHIP MICROCOMPUTER DEVELOPMENT SYSTEMS

Each of three products allows the IBM PS2/PC/XT/AT to be used as a complete development system for the Motorola 6805 series single chip microcomputers. MCPM-1 supports the MC68705 family, MCPM-2 supports the MC1468705 family and MCPM-3 supports the MC68HC05 family. Each system is \$495 and includes a programming circuit board with driver, cross assembler and Simulator/Debugger software. A system is also available for the HITACHI 63705 ZTAT micro.

THE ENGINEERS COLLABORATIVE
Route 3, Box 8C, Barton, VT 05822
(802) 525-3458 FAX (802) 525-3451

Circle 122 on Reader Service Card

NEW! INSTANT TERMINAL

"EXACT TERMINAL EMULATION AND COMMUNICATIONS SOFTWARE"

- PRECISE EMULATION OF THE DEC VT52, VT100, VT102, VT220
- EXPANSION MODULES FOR OVER 40 EXACT EMULATIONS
- 9 FILE TRANSFER PROTOCOLS.
- EASY TO USE, QUICK TO INSTALL, AND MUCH MORE
- IBM PC, XT, AT, PS/2

FOR INFORMATION
800/548-9777

SOFTRONICS
303/593-9540
TELEX 450236

ONLY **\$97.50**

Circle 307 on Reader Service Card



System 1800 Basic System \$899
(MADE IN U.S.A. with quality)
• Intel 80286 CPU
• Fully compatible with IBM AT
• 50 MHz selectable, 8 slots
• 25K on 1M modular board
• 195 watt power supply 110/220
• Class/Enter, Everex HOPD opt.
• FCC class "B" approved
• 48 Hour factory high temp. dynamic burn-in
• 1.2 MEG Teac Dr. Maxi switch AT Keyboard
• Rom-AutoLoad, Lotus, Staris, Novell, all prop. Software
• 200 pages of documentation (written in U.S.A.)
• 80287 CO-Processor socket
• 40,000 units installed with customer report on file
• Made in U.S.A.
with 1 year warranty

Mono Sys. (Basic Sys. + Evergraphics 132 col. w/tp, 14" Everex Flat Mon.)	\$1079
EGA Sys. (Basic Sys. + Everex EGA card + 14" Everex EGA [130mm] Mon.)	\$1414
Super EGA Sys. (Basic Sys. + Everex EGA card + NEC Winbase 8050 [130mm] Mon.)	\$1700
System 1800 10MHz '286' 0 wait 512K, 25, 1F, KB, Base system	\$1099
System 1700 10MHz '286' 0 wait 1 meg RAM, KB, Base system	\$1345
System 2000 10MHz '386' 0 wait, 1 meg, KB, Base system	\$1850

Upgrade Options: (Call for Everex products not listed)

A. Seagate 204MB/72M Harddisk \$250/\$325 B. 3 1/2" @ 720/1.4K	\$105/\$145
C. Everex 5MB 386	\$ 95
D. Everex PROCKET 1200 B. Modem	\$109
E. Everex Super EGA (800 x 600)	\$189
F. Mega VGA card	\$289
G. Genex Super EGA (800 x 600)	\$219
H. Panasonic 1080 printer	\$399

Schwab Computer Center
"The Everex Store" — Authorized Everex Dealer
3280 El Camino Real, Santa Clara, CA 95051
408-241-1210 Fax # 408-241-1279
M-F 10-7, SAT 11-4
Prices change without notice

Circle 293 on Reader Service Card

Bulk Diskettes

(100) FOR ONLY

5 1/4" DS-DD **29¢** ea.

With Tyvek Sleeves & Write on Labels

*Old Retailer Delaware 1-800-451-1849
P.O. BOX 10247, WILMINGTON, DE. 19850
the **Diskette Connection™** Oklahoma 1-800-654-4058
P.O. BOX 1674, BETHANY, OK. 73008
Nevada 1-800-621-6221
P.O. BOX 12396, LAS VEGAS, NV. 89112
Minimum Order 25.99 - Visa, MasterCard accepted,
COD add 3.99. UPS delivery. US Mail for APO, FPO
AK, HI, or PR add 5% additional for PAL.

LASER TONER KITS

TONER KIT 80 #5397-09



62.00 EACH

• OPC KITS "CALL"

*Old Retailer Delaware 1-800-451-1849
P.O. BOX 10247, WILMINGTON, DE. 19850
the **Diskette Connection™** Oklahoma 1-800-654-4058
P.O. BOX 1674, BETHANY, OK. 73008
Nevada 1-800-621-6221
P.O. BOX 12396, LAS VEGAS, NV. 89112

Nashua™

5 1/4" Double Side	2 Boxes	5 Boxes	10 Boxes
	* 5 ²⁵	5 ¹⁰	5 ¹⁰
High Density	9 ²⁵	8 ⁹⁵	8 ⁷⁵

	2 Boxes	5 Boxes	10 Boxes
3 1/2" MF2	13 ⁵⁰	12 ⁹⁵	12 ⁵⁰
3 1/2" HD 2 MB	35 ⁹⁵	35 ⁵⁰	33 ⁹⁵

*Old Retailer Delaware 1-800-451-1849
P.O. BOX 10247, WILMINGTON, DE. 19850
the **Diskette Connection™** Oklahoma 1-800-654-4058
P.O. BOX 1674, BETHANY, OK. 73008
Nevada 1-800-621-6221
P.O. BOX 12396, LAS VEGAS, NV. 89112
TELEX #4933362 — FAX #405 495 4598

Minimum order \$20.00. No Surcharge on Visa MasterCard. COD orders add \$3.99. Surface Shipping UPS add \$3.99 per 100 for 3 1/2" or 5 1/4", add \$4.99 per 100 for 8" U.S. Mail delivery add 9%. *Prices subject to change without Notice.

SPEECH PRODUCTS

For PCs and compatibles
SYNTHESIZER—only \$79.95



The next versatile and best sounding speech product available for under \$400! The amazing **Speech Thing** provides text-to-speech as well as PCM and ADPCM speech and music reproduction. Comes with "Thing" D/A converter that attaches to the parallel printer port **outside** the computer—ideal for laptops. Will not interfere with normal printer operation. Also comes with audio amplifier/speaker and power adapter. Software includes two advanced text-to-speech programs, digitized speech and music files, full screen waveform editor, sampling music keyboard, special effects mixing board, and drivers so you can add speech and sound effects to programs written in BASIC, C, PASCAL, and others. Includes 54 page manual. **SPEECH THING—\$79.95.**

DIGITIZER—only \$89.95



The **Voice Master PC Digitizer** is a full 8-bit PCM sampler board. Fits in any available slot. Up to 15,000 samples per second. Input pre-amp has automatic gain control and 4.5 KHz low pass filter. Includes a quality headset microphone. Software included for recording and editing sound files for playback through **Speech Thing**. Also includes a real-time spectrum display and oscilloscope display as well as assembly language source listings for writing your own drivers. **BONUS:** Voice recognition program included which is callable via an interrupt vector. Demonstration program written in GWBASIC. **VOICE MASTER PC DIGITIZER—\$89.95.**

VOICE RECOGNITION—only \$49.95



A price/performance break-through! Equal in performance to other systems costing hundreds more \$\$\$! The amazing **Voice Master Key** program adds voice recognition to just about any program or application. You can voice command up to 256 keyboard macros. Fully TSR and occupies less than 64K. Instant response time and high recognition accuracy. Easy and fun to use—no compilers or editors required. Works with CAD, desktop publishing, word processor, spread sheet, even other TSR programs. A genuine productivity enhancer. **Voice Master Key** can also be called from within a program for adding voice recognition to custom applications. **Voice Master Key** requires the **Voice Master PC Digitizer** for operation. (Please note: **Voice Master Key** will not replace the keyboard or mouse except under certain circumstances. Not to be confused with the still unavailable "voice typewriter.") **VOICE MASTER KEY—\$49.95.**

BONUS OFFER! Buy **Voice Master Key** with **PC Digitizer** for only **\$129.95**—you save \$10!

BETTER BONUS OFFER! Buy all three: **Speech Thing**, **PC Digitizer**, and **Voice Master Key** for only **\$189.95**—you save \$20!

ALL OF THESE PRODUCTS ARE OF PROFESSIONAL QUALITY.

ORDER HOTLINE: (503) 342-1271

Monday-Friday, 8 AM to 5 PM Pacific Time

Add \$5 for shipping and handling on all orders. Add an additional \$3 for 2nd day delivery. All goods shipped UPS. Master Card and VISA, money order, cashiers check or personal checks accepted (allow a 3 week shipping delay when paying by personal check). Foreign inquiries contact Covox for C&F price quotes. Specify computer type when ordering. **30 DAY MONEY BACK GUARANTEE IF NOT COMPLETELY SATISFIED. ONE YEAR WARRANTY ON HARDWARE.** Call or write for **FREE** product catalog.



COVOX INC. 675-D CONGER ST.,
EUGENE, OREGON 97402 U.S.A.
TEL: 503-342-1271 FAX: 503-342-1283

AVPROM™ \$295

For IBM-PC's & compatibles, menu-driven AVPROM programs EPROMs up to 8x faster than serially-connected units (20 sec. for 2764).

- Programs 2716 thru 27512A.
- 4- and 10 socket gang versions too. Call for prices.

For complete specs, free 32 pg. development tool catalog, call

800-448-8500.
or 207-236-9055

AVOCET

SYSTEMS, INC.®

120 Union St., Rockport, ME 04856

REAL WORLD I/O For PC/XT/ATs

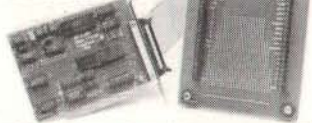

DG24 • 24-line digital I/O; 10 MHz 8255. **\$95**

AD500 • 8 channel 12-bit (plus sign) integrating A/D; programmable gains of 1, 10, & 100. Hi-Z input and 7 digital lines. **\$239**

AD100 • Single channel version of AD500 with 10 digital lines. **\$149**

AD200 • 4 channel, 125 uS, 12-bit A/D board. **\$239**

ADA300 • 8 channel, 25 uS, 8-bit A/D; single D/A; 24 TTL I/O lines (10 MHz 8255). **\$239**

DA600 • Fast settling dual 12-bit D/A. **\$169**

PD200 • Prototype/development board with address decoder, buffer, 100+ page application/project manual. **\$99**

XB40 • External connection/prototype board with cable. **\$49**

All boards include BASIC, Pascal, C, and Forth drivers. 30 day return; 1 year warranty. Call for "Real World Interfacing" application notes.

Real Time Devices, Inc.

P.O. Box 906 State College, PA 16804
(814) 234-8087

Circle 281 on Reader Service Card

OPTICAL DISKS



as featured in **PC WEEK 4/26/88**

- 800MB storage on single disk
 - connecting to any host via SCSI interface
 - Plug'n Play to any operating system
- only **\$4995** Limited time only

PANASONIC LS5000

\$2495 - 200 MB

OPTICAL MEDIA

For IBM & Panasonic Optical Drives - **\$52**

We carry a full line of **5 1/4" & 12" Optical Drives**

SKAN TEKNOLOGIES, INC.
optical storage systems
(212) 809-5570 (516) 295-2237

Circle 304 on Reader Service Card

9-Track Tape Subsystem for the IBM PC/XT/AT



Now you can exchange data files between your IBM PC and any mainframe or mini-computer using IBM compatible 1600 or 6250 BPI 9-Track tape. System can also be used for disk backup. Transfer rate is up to 4 magabytes per minute on PCs and compatibles. Subsystems include 7" or 10 1/2" streaming tape drive, tape coupler card and DOS compatible software. For more information, call us today!

QUALSTAR®

9621 Irondale Ave., Chatsworth, CA 91311
Telephone: (818) 882-5822

Circle 271 on Reader Service Card

SMART SWITCHES

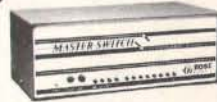

... at your command

Master Switch is sophisticated yet flexible. Several computers can access one another or share printers and modems. Use serial or parallel interfaces, up to nine ports. The buffer is expandable up to one megabyte. Access a job control menu from each computer to view the queue or cancel, hold, and release jobs. Many other features.

MasterNet software allows computer networking and electronic mail capabilities for PCs.

Other solutions from ROSE

- Printer Sharing
- Multiplexers
- Protocol Conversion
- Modems
- Buffering
- Manual Switches
- Micro to mainframe
- Cables

We design a variety of quality products for computer networking and data communication solutions guaranteed to work. Dealer and OEM inquiries are welcome.



ROSE
ELECTRONICS

P.O. BOX 742571 HOUSTON, TX 77274
CALL FOR CATALOG: 713 933 7673

Circle 287 on Reader Service Card
(DEALERS: 288)

Power Software

Batcom — Batch file compiler compiles your ".bat" files to ".exe" files to make them faster, more professional, and more capable. **\$49.95.**

REDCache — speeds hard disks by up to 7 times and floppy disks by up to 55 times. LIM EMS supported. **\$39.95.**

Spool — allows you to use your computer while your printer prints long documents. LIM EMS supported. **\$39.95.**

RED Utilities — Contains the three programs above plus protection from accidental hard disk formatting, sorted directories, text searching, DOS wild card exceptions, and much more. For IBM PC. **\$79.95.**

Check, COD, Visa, MasterCard.

Wenham Software Co.
5 Burley St.
Wenham, Ma. 01984
(508)-774-7036 **FREE** catalog.
Dealer inquiries invited.

Circle 359 on Reader Service Card

The Amazing A-BUS

NEW



An A-BUS system with two Motherboards
A-BUS adapter (IBM) in foreground

Plug into the future

With the A-BUS you can plug your PC (IBM, Apple, TRS-80) into a future of exciting new applications in the fields of control, monitoring, automation, sensing, robotics, etc.

Alpha's modular A-BUS offers a proven method to build your "custom" system today. Tomorrow, when you are ready to take another step, you will be able to add more functions. This is ideal for first time experimenting and teaching.

A-BUS control can be entirely done in simple BASIC or Pascal, and no knowledge of electronics is required!

An A-BUS system consists of the A-BUS adapter plugged into your computer and a cable to connect the Adapter to 1 or 2 A-BUS cards. The same cable will also fit an A-BUS Motherboard for expansion up to 25 cards in any combination.

The A-BUS is backed by Alpha's continuing support (our 11th year, 50000 customers in over 60 countries).

The complete set of A-BUS User's Manuals is available for \$10.

About the A-BUS:

- All the A-BUS cards are very easy to use with any language that can read or write to a Port or Memory. In BASIC, use INP and OUT (or PEEK and POKE with Apples and Tandy Color Computers)
- They are all compatible with each other. You can mix and match up to 25 cards to fit your application. Card addresses are easily set with jumpers.
- A-BUS cards are shipped with power supplies (except PD-123) and detailed manuals (including schematics and programming examples).

Relay Card

RE-140: \$129

Includes eight industrial relays. (3 amp contacts. SPST) individually controlled and latched. 8 LED's show status. Easy to use (OUT or POKE in BASIC). Card address is jumper selectable.

Reed Relay Card

RE-156: \$99

Same features as above, but uses 8 Reed Relays to switch low level signals (20mA max). Use as a channel selector, solid state relay driver, etc.

Analog Input Card

AD-142: \$129

Eight analog inputs. 0 to +5V range can be expanded to 100V by adding a resistor. 8 bit resolution (20mV). Conversion time 120us. Perfect to measure voltage, temperature, light levels, pressure, etc. Very easy to use.

12 Bit A/D Converter

AN-146: \$139

This analog to digital converter is accurate to .025%. Input range is -4V to +4V. Resolution: 1 millivolt. The on board amplifier boosts signals up to 50 times to read microvolts. Conversion time is 130ms. Ideal for thermocouple, strain gauge, etc. 1 channel. (Expand to 8 channels using the RE-156 card).

Digital Input Card

IN-141: \$59

The eight inputs are optically isolated, so it's safe and easy to connect any "on/off" devices, such as switches, thermostats, alarm loops, etc. to your computer. To read the eight inputs, simply use BASIC INP (or PEEK).

24 Line TTL I/O

DG-148: \$65

Connect 24 input or output signals (switches or any TTL device) to your computer. The card can be set for: input, latched output, strobed output, strobed input, and/or bidirectional strobed I/O. Uses the 8255A chip.

Clock with Alarm

CL-144: \$89

Powerful clock/calendar with: battery backup for Time, Date and Alarm setting (time and date); built in alarm relay, led and buzzer; timing to 1/100 second. Easy to use decimal format. Lithium battery included.

Touch Tone® Decoder

PH-145: \$79

Each tone is converted into a number which is stored on the board. Simply read the number with INP or POKE. Use for remote control projects, etc.

A-BUS Prototyping Card

PR-152: \$15

3 1/2 by 4 1/2 in. with power and ground bus. Fits up to 10 I.C.s

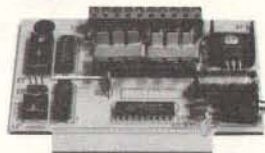

ST-143

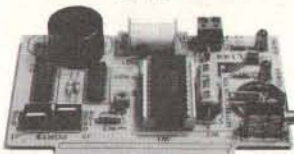

CL-144

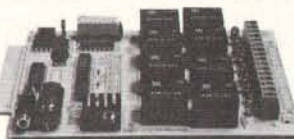

RE-140



IN-141

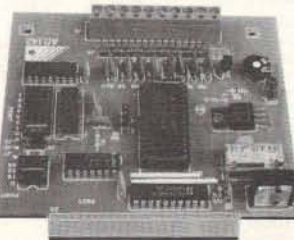

AD-142

Smart Stepper Controller sc-149: \$299

World's finest stepper controller. On board microprocessor controls 4 motors simultaneously. Incredibly, it accepts plain English commands like "Move arm 10.2 inches left". Many complex sequences can be defined as "macros" and stored in the on board memory. For each axis, you can control: coordinate (relative or absolute), ramping, speed, step type (half, full, wave), scale factor, units, holding power, etc. Many inputs: 8 limit & "wait until" switches, panic button, etc. On the fly reporting of position, speed, etc. On board drivers (350mA) for small steppers (MO-103). Send for SC-149 flyer.

Remote Control Keypad Option RC-121: \$49
To control the 4 motors directly, and "teach" sequences of motions.

Power Driver Board Option PD-123: \$89

Boost controller drive to 5 amps per phase. For two motors (eight drivers).

Breakout Board Option BB-122: \$19

For easy connection of 2 motors. 3 ft. cable ends with screw terminal board.

Stepper Motor Driver

ST-143: \$79

Stepper motors are the ultimate in motion control. The special package (below) includes everything you need to get familiar with them. Each card drives two stepper motors (12V, bidirectional, 4 phase, 350mA per phase).

Special Package: 2 motors (MO-103) + ST-143: PA-181: \$99

Stepper Motors MO-103: \$15 or 4 for \$39

Pancake type, 2 1/4" dia, 1/4" shaft, 7.5"/step, 4 phase bidirectional, 300 step/sec, 12V, 36 ohm, bipolar, 5 oz-in torque, same as Airpax K82701-P2.

Current Developments

Intelligent Voice Synthesizer, 14 Bit Analog to Digital converter, 4 Channel Digital to Analog converter, Counter Timer, Voice Recognition.

A-BUS Adapters for:

IBM PC, XT, AT and compatibles. Uses one short slot. AR-133...\$69

Tandy 1000, 1000 EX & SX, 1200, 3000. Uses one short slot. AR-133...\$69

Apple II, II+, IIe. Uses any slot. AR-134...\$49

TRS-80 Model 102, 200 Plugs into 40 pin "system bus". AR-136...\$69

Model 100. Uses 40 pin socket. (Socket is duplicated on adapter). AR-135...\$69

TRS-80 Mod 3, 4, 4 D. Fits 50 pin bus. (With hard disk, use Y-cable). AR-132...\$49

TRS-80 Model 4 P. Includes extra cable. (50 pin bus is recessed). AR-137...\$62

TRS-80 Model I. Plugs into 40 pin I/O bus on KB or E/I. AR-131...\$39

Color Computers (Tandy). Fits ROM slot. Multipak, or Y-cable. AR-138...\$49

A-BUS Cable (3 ft, 50 cond.)

CA-163: \$24

Connects the A-BUS adapter to one A-BUS card or to first Motherboard.

Special cable for two A-BUS cards: CA-162: \$34

A-BUS Motherboard

MB-120: \$99

Each Motherboard holds five A-BUS cards. A sixth connector allows a second Motherboard to be added to the first (with connecting cable CA-161: \$12). Up to five Motherboards can be joined this way to a single A-BUS adapter. Sturdy aluminum frame and card guides included.

Add \$3.00 per order for shipping.
Visa, MC, checks, M.O. welcome.
CT & NY residents add sales tax.
C. O. D. add \$3.00 extra.
Canada: shipping is \$5
Overseas add 10%



ALPHA Products

242-B West Avenue, Darien, CT 06820

Technical info: (203) 656-1806
Orders only 800 221-0916
Except in CT
Connecticut orders: (203) 348-9436
All lines open weekdays 9 to 5 Eastern time

EPROM PROGRAMMER CROSS ASSEMBLERS



MODEL
SX151

RS232C OR STAND ALONE (all models). Communication protocol: XMODEM, HEX, and BIN. Programs: EEPROMS, 2716 - 27512 and CMOS. Programs (w/adaptor): 25XX, 27101 (and above), 68701, 68705, 68764/6, 8741/2, 8744, 8748/9, 8751/2, 8755, 87252, and CMOS. More available soon. Model SX151 \$214 (assembled with case). Other models are available from \$49 (kit).

Cross assemblers by PseudoCode for IBM-PCs \$35. 280, 1802, 6502, 68001/2/3/5/8/9/11, 68000/8/10 8048/9, 8051/2, 8080/5, 8096, and more soon.



KORE, Inc.
6910 Patterson S.E.
Caledonia, MI 49316
(616) 791-9333

\$5 for shipping (USA), plus \$3.00 COD.

Circle 184 on Reader Service Card

PDK51



The \$595 Solution to 8051 Product Development

The PDK51 is a powerful and economical choice for the development of 8051-based systems. The PDK51 is used with an IBM-PC or equivalent and includes:

- SIBEC-II 8052 Basic Microcontroller
- SXA51 Cross Assembler
- ROM-Based Monitor/Debugger
- PROM Programmer
- Power Supplies
- Documentation, Tutorial and More

Call Now! (603) 469-3232



Binary Technology, Inc.

Main St., P.O. Box 67, Meriden, NH 03770

Circle 391 on Reader Service Card

Motion Control & Data Acquisition



on your IBM PC or Apple II
and all compatibles

Now for
MAC+ and SE

Smart 2 Axis Motion Controller: For many types of motors & encoders. New I.C. (from HP) allows changes & monitoring on the fly. Optically isolated. **W/SOFTWARE \$450** in U.S.
Four Axis Stepper Driver: With SOFTWARE & motor for instant automation. \$95.
Fast A/D Board: With programmed gain, 650 KHz, 4 inputs, \$220. Complete Scope hardware & SOFTWARE \$525. Also: 12 Bit A/D, Relay Driver, Real Time Clock. Circuit developers Project Book \$25.

How do you do it? Use our Local Applications Bus, LAB 40. One host adapter (\$150) supports up to 8 boards, like those above, on a 50 ft. ribbon cable.

Please call (415) 755-1978 for free literature.

Computer Continuum

75 Southgate Ave., Suite 6
Daly City, CA 94015

(415) 755-1978
Telex: 3727438
Night Modem: (415) 755-1524

ICs PROMPT DELIVERY!!!

SAME DAY SHIPPING (USUALLY)

QUANTITY ONE PRICES SHOWN FOR SEPT. 13, 1988

OUTSIDE OKLAHOMA: NO SALES TAX

DYNAMIC RAM			
1Mbit	1Mx9	85 ns	\$495.00
1Mbit	1Mx1	100 ns	38.50
41256	256Kx1	60 ns	14.50
41256	* 256Kx1	80 ns	13.75
41256	256Kx1	100 ns	13.75
51258	* 256Kx1	100 ns	12.95
41256	256Kx1	120 ns	12.75
41256	256Kx1	150 ns	11.75
41264	+ 64Kx4	120 ns	18.95
EPROM			
27C1000	128Kx8	150 ns	\$37.95
27C512	64Kx8	200 ns	13.95
27256	32Kx8	250 ns	7.25
27128	16Kx8	250 ns	6.60
STATIC RAM			
43256L-10	32Kx8	100 ns	\$18.95
6264P-12	8Kx8	120 ns	13.50

640K WOTHERBDD UPGRADE: Zenith 150,
IBM PC XT, Compaq Portable & Plus, hp Vectra

* STATIC
COLLIM
DRAM
* 2 PORT
VIDEO
RAM
80387-16
80387-20
80387-2
80387-8
\$245.00
\$160.00

OPEN 6 1/2 DAYS, 7:30 AM-10 PM. SHIP VIA FED-EX ON SAT.

WE EXPORT ONLY TO CANADA, GUAM, PUERTO RICO & VIRGIN ISLANDS

SAT DELIVERY INCLUDED ON FED-EX ORDERS RECEIVED BY: The 2nd Air \$6.3 (B) Fr. P.I. \$10.25 (1/B)
MasterCard/VISA or UPS CASH COD
Factory New, Prime Parts μ Proc. MICROPROCESSORS UNLIMITED, INC. 24,000 S. Peoria Ave. (918) 267-4961 BEGGS, OK 74421
No minimum order. Please note that prices are subject to change. Shipping & insurance extra. \$ up to \$1 for packing materials. Orders received by 9 PM CST can usually be delivered the next morning, via Federal Express Standard Air @ \$5.00, or guaranteed next day Priority One @ \$10.25!

Circle 219 on Reader Service Card

Get the whole story on graphics terminal emulation.



To find out more about software that lets your PC emulate TEKTRONIX™ 4105/6/7/9 and DEC VT100™ terminals, call or write:

GRAFPPOINT

4340 Stevens Creeks Blvd., Suite 280,
San Jose, CA 95129 (408) 249-7951

Circle 144 on Reader Service Card

HARD DISK CONTROLLERS

ADAPTEC		
PC/XT Controller ST506/412		\$45
2070 PC/XT to 506/412 RLL		\$69
2071 PC/XT to ST506 RLL (1 drive)		\$59
2072 PC/XT RLL		\$79
2370 PC/XT to ST506 RLL		\$99
3530 SCSI to Tape CMC 36		\$78
4000 SCSI to ST506/412		\$89
4000A SCSI to ST506/412		\$129
4070 SCSI to ST506/412 RLL		\$98
4520 SCSI to ESDI		\$98
5500 SCSI to ST506/412		\$125
5580 SCSI to SMD		\$175

XEBEC		
S1410 SASI Controller		\$89
S1420 SASI to 5 1/4" Floppy & Hard Disk Controller		\$29
Apple II, III+, IIE Host Adapter		\$29

OTHERS		
DTC 510A SASI controller		\$98
DTC 5187 AT to ST506/412, No Floppy		\$98
Konon DI-210 3 1/2" SASI to ST506/412 (Xebec 1410 clone)		\$89
WD 1002-SHD Xebec Compatible SASI Controller		\$109
Western Digital 1003WAH		\$119
Manuals	\$8 each	
Cables Available	Ask for Pricing	
Hard Drives 20-380 MB		Call

Computer Surplus Store
715 Sycamore Dr. • Milpitas, CA 95035
Phone: 408-434-1060
Fax: 408-434-0931
Tlx: 1561447
"We Buy and Sell!"

Circle 79 on Reader Service Card

IMAGING CARD



DV-01 GRAY SCALE FRAME GRABBER

Composite video in/out
256 x 240 resolution
Digitize/display at frame speed
256 gray levels in
16 Meg. color palette out
PC/XT/AT compatible

\$849.00 Complete with software
VISA/MC Demo Disk available

Control Vision
P.O. Box 596, Pittsburg, KS 66762
(316) 231-6647

Circle 82 on Reader Service Card

FREE!

Turn-key
PC Systems
Handbook

NEW 1988
Fall/Winter
Edition

Save Time and Money
Over 1000 Hard-to-find
Hardware and Software
Items of Special
Interest to Technical
PC Users:

- RS 232/IEEE 488 Networks & Stepping & Servo
- Motor Controls
- Ruggedized PCs
- Rack Mtg. 80286 & 80386
- Laboratory Automation
- 1 MHz A/D
- Digital Scopes to 200 MHz
- High Speed Bus Adapters
- Waveform Synthesizers
- Data Loggers
- PC Bus Expansion Chassis
- And Much More

Call or write for a FREE
handbook today!
203-786-5151 Ext. 101
(9:00 AM to 5:00 PM E.S.T.)



A How-to-Handbook that enables you to configure the BEST products from the world's leading PC hardware and software vendors into risk free turn-key system solutions that meet your needs.
Toll Free Hotline for application assistance and convenient one stop shopping at competitive prices. 100% Satisfaction Guaranteed.

CyberResearch Inc.
P.O. Box 9565, New Haven, CT 06536
Fax: 203-786-5023 Telex: 9102501037

Circle 87 on Reader Service Card

ZSTEM

VT220 D400
VT240
TERMINAL EMULATION

KEA SYSTEMS LTD.

#412 - 2150 West Broadway
Vancouver, B.C. CANADA, V6K 4L9
Tel: 604-732-7411 Telex: 04-352848 VCR
FAX: 604-732-0715
Order Toll Free (800) 663-8702

**KEA
SYSTEMS**

Circle 179 on Reader Service Card

California Digital

17700 Figueroa Street • Carson, California 90248



Color Monitor
Better Than
EGA
~~\$1095~~ **\$289**

Ideal for CAD/CAM and Desk Top publishing applications. The Roland CD/240 color monitor has a resolution of 720 pixels by 400 lines on a 31mm dot pitch 12" non-glare screen. VGA specifications in text mode EGA in graphic mode.

Comparable monitor and card packages retail at over \$1095. California Digital has made a special purchase and is able to offer the CD/240 and 132 column VGA/EGA graphic card for only \$389.

20" Analog Color
~~\$1895~~ **\$659**



Ever try gathering a classroom of students around a 12 inch monitor? This 20 inch analog RGB monitor is the ideal solution. High screen resolution of 1200 pixels by 950 lines allow extra fine detail without the dots looking like golf balls. 256 colors and VGA compatible. Super value originally sold for over \$2000. Only 350 available.

40 Meg. Tape Back-up
~~\$659~~ **\$239**



Head Crash, Power Spikes or just poor disk maintenance... don't loose data because you didn't back up. The All/40 is an expensive way to save and restore files in the event that your data has been destroyed. This 40 megabyte half height tape back is manufactured by North Americas largest producer of data retrieval equipment. To need to purchase a separate tape controller... the ALL/40 attaches directly to your existing floppy disk controller. Supplied software allows your computer to back up any time Day or Night. Come back in the morning and 40 megabytes of irreplaceable data has been stored on one Scotch DC/2000 data cassette. Back up entire hard disk, modified files only, or by file name. Loss of data is inevitable but when you are backed up on an ALL/40 its not a catastrophe.



	One	Two	Ten
TEC501 1/2 height sgl.side	49	39	35
TANDON 101/4 full ht. 96 TPI.	99	89	79
FUJITSU 5 1/4" half height	65	63	57
MITSUBISHI new 501 half ht.	119	109	105
MITSUBISHI 504A AT comp.	149	139	135
TEAC FD55BV half height	89	85	79
TEAC FD55FV 96 TPI, half ht.	119	109	105
TEAC FD55GF for IBM AT	109	105	99
PANASONIC 455 Half Height	109	99	89
PANASONIC 475 1.2 Meg./96	119	115	109
Switching power supply			49
Dual enclosure for 5 1/4" drives			59

3 1/2" DISK DRIVES			
SONY MP-53W 720K/Byte	129	125	119
SONY MP-73W, 2 Meg.	159	149	call
TEAC 35FN 720 K/Byte	129	119	115
TEAC 35HN/30, 2 Meg.	159	149	145
5 1/4" form factor kit			20

8" DISK DRIVES			
QUME 842 double sided	189	179	175
QUME 841 single sided	119	109	99
SHUGART 851R dbl. sided	319	309	299
REMAX RFD4000 dbl. sided	189	179	165
OLIVETTI 851	189	179	165

NEC/890 Laser Printer
~~\$3295~~ **\$3295**

PC Magazine has chosen the NEC-890 best laser printer of the year. (Jan. 12, 1988). And its obvious why... the printer is Postscript, Hewlett Packard, and Apple compatible, and comes standard with three megabytes of memory. The 890 accepts data from parallel, serial and Apple-Talk devices. NEC has also incorporated 40 built-in fonts along with two paper trays into this industrial quality laser printer.

- Hewlett Packard Laser II, 8 pages per minute..... \$1659
- QMS PS/810 2 Meg., 35 fonts, Postscript 8 pgs..... 3879
- Apple Laser Writer II..... 1899
- Texas Instruments 2115 Postscript 15 pgs..... 5426
- Quadram Quadlaser with 5 megabytes..... 2995

Hitachi CD-ROM
~~\$495~~ **\$495**



Compact disk is a relatively new medium for storage of read-only digital data. One removable disk is capable of storing over 500 megabyte of data on a disk the same size as an audio CD. The CDR-3500 will install in a PC in the space of one 5 1/4" drive. Other CD-ROM Products Available: Sony 510 internal \$539; Amdisk Laserdrive/1 system \$679; Hitachi CDR-1503SUY external with IBM host adapter and MS ext. DOS \$699; Panasonic WORM drive \$1895.

Summagraphics DIGITIZER
~~\$219~~ **\$219**

The Summagraphics Bit Pad is a 12 by 12 inch high resolution digitizer that easily connects to the serial port of your computer. Included four button cursor with crosshair sights is ideal for tracing, digitizing and menu selecting. While supplies last, California Digital is offering this \$595 Summagraphics Bit Pad digitizer for only \$219.

Hitachi 11 by 17 Plotter
~~\$895~~ **\$695**



The Hitachi 672/XD is a four color 11 by 17 (B size) plotter with superior accuracy and repeatability (.3mm). The 672 accepts HPGL 7475 commands and is both Centronics parallel and RS232C compatible. The 672 plots at a fast eight inches per second in axial direction and eleven inches at an angle of 45 degrees. The plotter also features a self contained digitizing function that allows data to be entered into your computer from printed graphs and blue prints. Four different color pens are supplied with the plotter but a wide variety of technical pens are available.

Heath H/89 Computer
~~\$179~~ **\$179**



Hard to believe... but we found a stash of brand new Zenith/Heath Model H/89 computers. These computers feature the Zilog Z-80 CPU and operate under CP/M. The unit incorporates a 12 inch green screen, three serial ports and one 5 1/4" disk drive. Zenith's original price was \$1895. We have 350 units available for sale, while supplies last we are offering the H/89 at only \$179. Word processing and communication software included.

Panasonic INFO CENTER
~~\$1395~~ **\$295**



Panasonic's Information Center is the perfect tool for any executive who is concerned about efficient use of time. Incorporated in a single sleek enclosure is a two line speakerphone with conference calling and 100 number auto dial phone directory. Transmit, receive and edit MS/DOS files via the self contained 1200 baud auto-Logon modem. Connects to your host computer, logs in and enters your security password all with one key stroke! Press another button and the InfoCenter is ready to auto receive (unattended) files to a 360K/byte disk drive. Insert the diskette into your PC and your ready work on information just received from your branch offices. Compact Telex terminal... Connect to Western Union and you're ready to transmit, receive and edit World wide Telex and TWX communications. Besides all this the InfoCenter doubles as a VT-100 nine inch amber screen terminal that is ready to connect to your PC or Minicomputer. Need hard copy...No problem. Connect any Centronic compatible device directly to the printer port, you're ready to output from screen, disk, modem or Telex. Time management, phone log, clock-calender appointment reminder alarm and memo pad are just a few of the features you can expect from the Panasonic IX-D4985 InfoCenter. One hundred page reference manual is available for \$10. May be applied to \$295 purchase price.

\$119 2400 Baud Modem

2400 baud with forward error correcting make the Moxon MAX/2400 an unbelievable value at only \$119. Fully compatible with the Hayes command set and CCITT V.22 standards. Error correcting, autobauding and "adaptive equalization" allow the MAX/2400 to maintain reliable data transmission over marginal phone lines. Manufactured by Moxon Systems, one of the Worlds largest producers of consumer electronics. Originally priced at \$295. While supplies last California Digital is offering the MAX/2400 at only \$119.

40 Megabyte Hard Disk Kit
~~\$397~~ **\$397**

Forty megabyte internal hard disk drive, controller and cables all for only \$397. The kit includes the a 40 milisecond Miniscribe 3650 drive and a half slot Western Digital controller.

Five Inch Winchester Disk Drives	
Price does not include controller.	each two+
SEAGATE 225 20 Meg. 1/2 Hr. 239	229
SEAGATE 238 30 Meg. RLL 259	249
SEAGATE 251/1 51 M. 28ms. 459	445
SEAGATE 4096 96 M. 35ms. 659	639
MINISCRIBE 8425 25 M 65ms 239	227
MINISCRIBE 3650 50M 61 ms. 419	399
MINISCRIBE 6085 90 meg. 795	779
MINISCRIBE 3053 25 ms. 1/2 ht. 459	439
FUJITSU 2242 55 M. 35mS. 1299	1279
FUJITSU 2243 86 M. 35mS. 1695	1619
RODIME RO-204E 53 Meg. 895	859
MAXTOR XT1140 140 Meg. 1595	1550
MAXTOR XT2190 192 Meg. 1919	1875
TOSHIBA MK5670 M. 30mS. 1289	1229
CONTROL DATA WREN "V" call	

Winchester Controllers for IBM/PC	
XEBEC 1220 with floppy controller	159
DTC 5150CX	119
OMTI 5527 RLL controller	99
ADAPTEC 2070 RLL controller	99
ADAPTEC 2372A 1/1 interleaf	159
WESTERN DIGITAL WD/1002WX2	89
WESTERN DIGITAL 1003WAH or WA2	139
WESTERN DIGITAL 1007/WA2 ESDI	239
SCSI/SASI Winchester Controllers	
XEBEC 1410A 5 1/4" foot print	239
WESTERN DIGITAL 1002-05E 5 1/4"	229
OMTI 20L	89

Winchester Accessories	
Dual floppy enc. and powersupply	59
Winchester enclosure and supply	139
Switching power supply	49



Every year since 1973, customers from virtually every nation in the free World have chosen California Digital for their data processing requirements. If its computer, California Digital has it... complete minisystem or just one microchip. California Digital offers over 10,000 unique computer products. Regardless of how specialized your data processing requirements... California Digital is your one stop shopping solution.

TECHNICAL & CALIFORNIA
(213) 217-0500
TOLL FREE ORDER LINE
(800) 421-5041

Telefax • (213) 217-1951

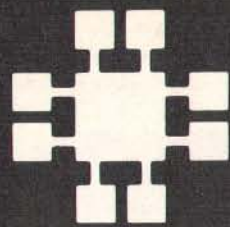

JDR Microdevices

MMC
MICROCOMPUTER
MARKETING COUNCIL
of the Direct Marketing Association, Inc.

• 30 DAY MONEY BACK GUARANTEE • 1 YEAR WARRANTY ON ALL PRODUCTS • TOLL-FREE TECHNICAL SUPPORT
• COMPLETE CUSTOMER SATISFACTION • SUPERIOR SERVICE • FRIENDLY, KNOWLEDGEABLE SALES STAFF

2400 BAUD MODEMS

\$129⁹⁵

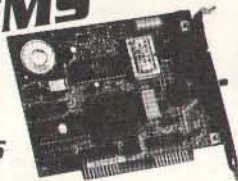

\$169⁹⁵



SAVE TIME AND TELEPHONE CHARGES WITH A HIGH SPEED 2400 BAUD MODEM FROM JDR.

INTERNAL 2400 BAUD

- AUTO DIAL ANSWER
 - SELF TEST ON POWER-UP
 - TOUCHTONE OR PULSE DIALING
 - HAYES & BELL SYSTEMS COMPATIBLE
 - FULL OR HALF DUPLEX
 - MIRROR II COMMUNICATIONS SOFTWARE INCLUDED
- PRO-24I** **\$129.95**
PRO-12I 1200 BAUD 1/2 CARD **\$69.95**
PRO-24M 2400 BAUD FOR PS/2 **\$249.95**

EXTERNAL 2400 BAUD

- 2400/1200/300 HAYES COMPATIBLE
 - 8 EASY-TO-READ STATUS LED'S
 - CALL PROGRESS MONITORING & ADJUSTABLE VOLUME
 - 2ND PHONE JACK FOR VOICE COMMUNICATIONS
 - REQUIRES SERIAL PORT & CABLE (OPTIONAL)
- PRO-24E** **\$169.95**
PRO-12E 1200 BAUD EXTERNAL **\$99.95**

APPLE/MACINTOSH MODEMS

- MACINTOSH 2400 BAUD EXTERNAL AS ABOVE WITH CABLE AND PROCOM-M SOFTWARE.
- PRO-24EM** **\$199.95**
PRO-24A APPLE II 2400 BAUD MODEM **\$179.95**
PRO-12A APPLE II 1200 BAUD MODEM **\$139.95**

POCKET MODEM

\$99⁹⁵



YOU'LL NEVER BE FAR FROM YOUR DATA WITH THIS 6 OUNCE HAND-HELD POCKET MODEM

- 1200/300 BAUD ■ BATTERY & AC POWER
 - SERIAL INTERFACE (DB25) ■ 4 STATUS INDICATORS
- PRO-12P**

KEYBOARDS

MODULAR CIRCUIT TECHNOLOGY

- ENHANCED STYLE LAYOUT
- AUTONSENSE FOR XT OR AT COMPATIBLES
 - LED INDICATORS ■ AUTO REPEAT FEATURE
 - SEPARATE CURSOR PAD
- BTC-5339** **\$79.95**

- 84 KEY LAYOUT**
- SOFTWARE AUTONSENSE FOR XT OR AT COMPATIBLES
 - LED INDICATORS ■ AUTO REPEAT
- BTC-5060** **\$59.95**

MAXI-SWITCH KEYBOARDS

- WITH TACTILE FEEDBACK
- MAX-5339** ENHANCED STYLE LAYOUT **\$84.95**
MAX-5060 84 KEY LAYOUT **\$64.95**

AUDIBLE "CLICK" KEYBOARD

- ENHANCED STYLE, 101 KEY KEYBOARD
 - LED INDICATORS ■ AUTO REPEAT
- K-103-A** **\$84.95**

HANDY SCANNER

\$249⁹⁵



INSTANT SCANNING OF IMAGES UP TO 4" WIDE

- 100, 200, 300, 400 DPI BOTH DIRECTIONS
 - B&W AND 3 HALF-TONE MODES
 - 32 LEVELS OF GRAY SCALE
 - HERCULES, CGA AND EGA COMPATIBLE
 - INCLUDES HALO DPE AND IMAGE EDITOR SOFTWARE
- HS-3000**

LOGITECH HIREZ MOUSE

\$129⁹⁵



HIGH RESOLUTION BUS MOUSE FOR BETTER RESPONSE AND LESS HAND MOVEMENT, IDEAL FOR CAD WORK

- 320 DPI ■ INCLUDES DRIVER, TEXT EDITOR & POP-UP MENUS
- NO PAD, POWER SUPPLY OR PORT REQUIRED

LOGITECH 3-BUTTON MOUSE

- PC MAGAZINE EDITORS CHOICE! ALL MODELS HAVE SERIAL SUPPORT (COM1/COM2), 200 D.P.I. RESOLUTION, LOTUS 1-2-3 SHELL, SELF-INSTALLING SOFTWARE AND "POINT EDITOR"
- LMOUSE** **\$79.95**
LMOUSE-P SERIAL MOUSE W/LOGIPAINT **\$89.95**
LMOUSE-BP BUS MOUSE W/LOGIPAINT **\$89.95**
LMOUSE-BPL BUS MOUSE W/PUBLISHER PKG **\$139.95**
LMOUSE-BPC BUS MOUSE W/LOGIPAINT/CAD **\$149.95**

CALL OUR 24-HOUR BBS (408) 374-2171

JDR'S ELECTRONIC BULLETIN BOARD OFFERS TECHNICAL SUPPORT, CONFERENCING AND MORE

CITIZEN PRINTER

\$219⁹⁵



A RELIABLE, FAST AND INEXPENSIVE ALL PURPOSE PRINTER THAT'S LOADED WITH FEATURES

- 9 PIN DOT MATRIX PRINT HEAD
 - 180 CPS DRAFT MODE, 29 CPS NLQ MODE
 - CENTRONICS PARALLEL INTERFACE, SERIAL OPTIONAL
 - DUAL PITCH, DOUBLESTRIKE, ITALICS & SUPERScript
 - EPSON FX & IBM GRAPHICS
 - COMPRESSED, EXPANDED & EMPHASIZED PRINT
 - DOT ADDRESSABLE GRAPHICS IN SIX DENSITIES
- CITIZEN-180D**
RC-180D REPLACEMENT RIBBON CARTRIDGE **6.95**

MOLDED CABLES

- CBL-PRINTER** PC PRINTER CABLE **\$9.95**
CBL-PRINTER-25 AS ABOVE - 25 FOOT **\$15.95**
CBL-PRINTER-RA RIGHT ANGLE PRINTER **\$15.95**
CBL-DB25-MM DB25 MALE TO DB25 MALE **\$9.95**
CBL-DB25-MF DB25 MALE TO DB25 FEMALE **\$9.95**
CBL-9-SERIAL 9 PIN TO 25 PIN SERIAL **\$6.95**
CBL-KBD-EXT KEYBOARD EXTENSION **\$7.95**
CBL-CNT-MM 36 PIN CENTRONICS-MM **\$14.95**
CBL-HD-20 20 PIN HARD DISK CABLE **\$3.95**
CBL-HD-34 34 PIN HARD DISK CABLE **\$4.95**
CBL-HD-34D 34 PIN DUAL HARD DISK **\$6.95**
CBL-FDC-EXT 37 PIN EXTERNAL FLOPPY **\$9.95**

VGA COMPATIBLE PACKAGE

\$649⁰⁰



- 800 X 560 MAXIMUM RESOLUTION
- 640 X 480 IN 16 COLORS
- 320 X 200 IN 256 COLORS
- IBM STYLE, ANALOG MONITOR
- FULLY VGA, EGA, CGA, HERCULES & MONOCHROME COMPATIBLE

NEC MULTISYNC II

\$599.95

- AUTO FREQUENCY ADJUSTMENT
- RESOLUTION AS HIGH AS 800 X 560

CASPER EGA

\$399.95

- 640 X 200/350 RESOLUTION ■ 31 MM DOT PITCH
- 14" BLACK MATRIX SCREEN ■ 16 COLORS

CASPER RGB

\$279.95

- COLOR GREEN AMBER SWITCH ■ .39MM DOT PITCH
- 640 X 240 RESOLUTION ■ 14" NON-GLARE SCREEN

SAMSUNG MONO

\$129.95

- 12" NON-GLARE LOW DISTORTION AMBER SCREEN
- 720 X 350 RESOLUTION ■ SWIVEL BASE

MONITOR STANDS

- MODEL MS-100** **\$12.95**
 ■ TILTS AND SWIVELS
MODEL MS-200 **\$39.95**
 ■ TILTS AND SWIVELS ■ BUILT-IN SURGE SUPPRESSOR
 ■ INDEPENDENTLY CONTROLS UP TO 5 AC OUTLETS

TOWER CASE

\$299⁹⁵

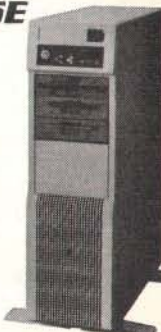

SAVE DESKSPACE AND ADD STYLE TO YOUR OFFICE WITH THIS SLEEK UPRIGHT DESIGN

- ACCOMMODATES ALL SIZES OF MOTHERBOARDS
- 250 WATT POWER SUPPLY INCLUDED
- MOUNTS FOR 3 FLOPPY & 4 HARD DRIVES
- TURBO & RESET SWITCH
- SPEED DISPLAY, POWER & DISK LED'S
- MOUNTING HARDWARE, FACEPLATES & SPEAKER INCLUDED

CASE-100

- CASE-FLIP** FOR 8088 MOTHERBOARDS **\$34.95**
CASE-SLIDE FOR 8088 MOTHERBOARDS **\$39.95**
CASE-70 FOR 286 MOTHERBOARDS **\$89.95**
CASE-JR MINI-286 W/POWER SUPPLY **\$149.95**

POWER SUPPLIES

- 135 WATT 110/220V** **\$59.95**
 ■ UL APPROVED
 ■ IBM XT COMPATIBLE
 ■ +5V, -15A, +12V 4.2A, -5V, .5A, -12V .5A
- PS-135**
- PS-150** 150W 110/220V **\$69.95**
- 200 WATT 110/220V** **\$89.95**
 ■ U.L. APPROVED
 ■ IBM AT COMPATIBLE
 ■ +5V 22A, +12V 8A, -5V .5A, -12V .5A
- PS-200**
- PS-250** 250 WATT 110/220V **\$129.95**



JDR MICRODEVICES AND THE JDR MICRODEVICES LOGO ARE REGISTERED TRADEMARKS OF JDR MICRODEVICES. IBM, AT, PS/2 ARE TRADEMARKS OF INTERNATIONAL BUSINESS MACHINES.

1.44 MB 3 1/2" DRIVE

\$149.95

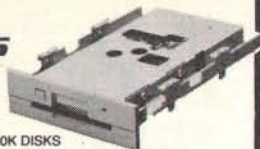

- ULTRA HIGH DENSITY
- ALSO WORKS WITH 720K DISKS
- FDD-1.44X BLACK FACEPLATE
- FDD-1.44A BEIGE FACEPLATE

1/2 HEIGHT FLOPPY DISK DRIVES

FD-55B	5-1/4" TEAC DS/DD 360K	\$99.95
FD-55G	5-1/4" TEAC DS/HD 1.2M	\$129.95
M2551A	5-1/4" FUJITSU DS/DD 360K	\$89.95
M2553K	5-1/4" FUJITSU DS/HD 1.2M	\$119.95
FDD-360	5-1/4" DS/DD 360K	\$69.95
FDD-1.2	5-1/4" DS/HD 1.2M	\$109.95
FDD-3.5A	3-1/2" MITSUBISHI DS/DD(BEIGE)	\$129.95
FDD-3.5X	3-1/2" MITSUBISHI DS/DD(BLACK)	\$129.95

TAPE BACK-UP DRIVES

AR5240X	ARCHIVE TAPE DRIVE -XT'S & AT'S	\$369.95
AR5540A	FASTER TAPE DRIVE -AT'S ONLY	\$369.95
AR340	40 MB TAPE CARTRIDGES	\$24.95

DISKETTES

N-MD2D	BOX OF 10 5-1/4" 360K DS/DD	\$6.95
N-MD2H	BOX OF 10 5-1/4" 1.2 MB DS/HD	\$13.95
N-3.5DS	BOX OF 10 3-1/2" 720K DS/DD	\$16.95
N-3.5HD	BOX OF 10 3-1/2" 1.44 MB DS/HD	\$49.95
N-MD2DBULK	360K DS/DD (MIN. 50 DISKS)	EA. 49¢

DRIVE ACCESSORIES

FD-ARAIL	MTG. RAILS FOR AT COMPATIBLE	\$2.95
FD-55FP	BEIGE FACEPLATE FOR TEAC DRIVES	\$2.95
FD-55MHW	HALF-HEIGHT MOUNTING HARDWARE	\$2.95
FD-5Y	Y-POWER ADAPTOR FOR DRIVES	\$2.95

Seagate HARD DISKS

Whatever your hard disk needs, we have reliable, high quality Seagate drives at the lowest prices available. Buy them alone, or with an MCT disk controller for even greater savings!



SIZE	MODEL	AVG. SPEED	HEIGHT	DRIVE ALONE	WITH MCT CONTROLLER			
					HDC	RLL	AFH	AFH-RLL
20MB	ST-225	65 ms	Half	\$225	\$269	-	\$339	-
30MB RLL	ST-238	65 ms	Half	\$249	-	\$299	-	\$389
40MB	ST-251	40 ms	Half	\$429	\$469	-	\$539	-
40MB	ST-251-1	28 ms	Half	\$529	\$569	-	\$639	-
60MB RLL	ST-277	40 ms	Half	\$499	-	\$549	-	\$639
30MB	ST-4038	40 ms	Full	\$559	\$603	-	\$659	-
80MB	ST-4096	28 ms	Full	\$895	\$939	-	\$995	-

NEW!! SIGMA VGA CARD

\$279.50

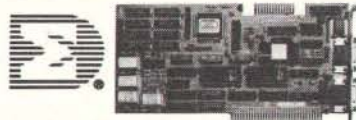

- 100% REGISTER COMPATIBLE VGA DISPLAY CARD
 - VGA, EGA, CGA, HGC & MDA COMPATIBLE
 - 320 X 200 IN 256 COLORS
 - 640 X 480, 800 X 600 IN 16 COLORS
 - 80 X 25, 132 X 44 TEXT MODES
 - SUPPORTS STANDARD DIGITAL & ANALOG MONITORS
 - UTILITY SOFTWARE INCLUDED
- MCT-VGA

“Your products and prices have kept us coming back now for two years...keep up the good work.”
—P.S., Sterling Heights, MI

“We'll continue to do business with you whenever we can.”
—James Hillegass, Minneapolis, MN

“...I will not hesitate to order anything from JDR —because I know your policy is to stand behind your products 100%.”
—Robert Rindy, Grand Forks, NB

“I found JDR's tech support to be responsive, helpful and honest.”
—N.G., Meadville, NY

INTERFACE CARDS

BY MODULAR CIRCUIT TECHNOLOGY

DRIVE CONTROLLERS

FLOPPY DISK CONTROLLER \$29.95
SINGLE SLOT CONTROL OF 4 FLOPPIES
■ INTERFACES UP TO 4 FDD'S TO AN IBM PC OR COMPATIBLE ■ SUPPORTS DS/DD AND DS/OD W/ DOS 3.2
MCT-FDC

1.2 MB FLOPPY CONTROLLER \$69.95
ADD VERSATILITY AND CAPACITY TO YOUR XT
■ SUPPORTS 2 DRIVES, CAN MIX 360K AND 1.2 MB
■ ALLOWS DATA TO FLOW FREELY FROM XT'S TO AT'S
MCT-FDC-1.2

FLOPPY/HARD CONTROLLER \$139.95
XT SYSTEM SHORT OF SLOTS? THIS CARD FREES ONE UP!
■ INTERFACES UP TO 2 FDD'S & 2 HDD'S, CABLING FOR 2 FDD/1HDD ■ SUPPORTS BOTH DS/DD & DS/OD W/DOS 3.2
MCT-FH

286/386 FLOPPY/HARD \$149.95
FLOPPY/HARD DISK CONTROL IN A TRUE AT DESIGN
■ SUPPORTS UP TO 2 360K/720K/1.2 MB FDD'S
■ SUPPORTS 2 HDD'S USING STANDARD TABLES
MCT-AFH

HARD DISK CONTROLLER \$79.95
HARD DISK CONTROL AT AN ECONOMICAL PRICE
■ SUPPORTS 16 DRIVE SIZES INCLUDING 10,20,30 & 40 MB
■ DIVIDE 1 LARGE DRIVE INTO 2 LOGICAL DRIVES
MCT-HDC

RLL CONTROLLER \$119.95
TRANSFER DATA 50% FASTER
■ SUPPORTS UP TO 2 RLL HARD DRIVES
■ DESIGNED FOR XT COMPATIBLES
MCT-RLL

286/386 FLOPPY/HARD RLL \$199.95
IMPROVE SPEED AND STORAGE OF YOUR AT COMPATIBLE
■ SUPPORTS UP TO 2 RLL HARD DISCS AND 2 FLOPPIES
■ SUPPORTS 360/720/1.2 MB FLOPPIES IN 5.25" & 3.5"
MCT-AFH-RLL

MULTIFUNCTION CARDS

MULTI I/O FLOPPY CONTROLLER \$79.95
A PERFECT COMPANION FOR OUR MOTHERBOARDS
■ SUPPORTS UP TO TWO 360K FLOPPIES, 720K W/ DOS 3.2
■ SERIAL, PARALLEL, GAME PORT, CLOCK/CALENDAR
MCT-MIO
MIO-SERIAL—2ND SERIAL PORT \$15.95

MULTI I/O CARD \$59.95
USE WITH MCT-FH FOR MINIMUM OF SLOTS USED
■ SERIAL PORT, CLOCK/CALENDAR WITH BATTERY
■ PARALLEL PORT ADDRESSABLE AS LPT1 OR LPT2
MCT-IO

286/386 MULTIFUNCTION \$139.95
ADDS UP TO 3 MB OF RAM TO YOUR AT
■ USER EXPANDABLE TO 1.5 MB OR 3 MB WITH OPTIONAL PIGGYBACK BOARD (OK INSTALLED) ■ INCLUDES SERIAL AND PARALLEL PORT
MCT-AMF
MCT-AMF-MC PIGGYBACK BOARD \$29.95
AMF-SERIAL 2ND SERIAL PORT \$24.95

286/386 MULTI I/O CARD \$59.95
USE WITH MCT-AFH MINIMUM OF SLOTS USED
■ SERIAL, PARALLEL AND GAME PORTS ■ USES 16450 SERIAL SUPPORT CHIPS FOR HIGH SPEED OPS
MCT-AIO
AIO-SERIAL 2ND SERIAL PORT \$24.95

MEMORY CARDS

576K RAM CARD \$59.95
A CONTIGUOUS MEMORY SOLUTION IN A SHORT SLOT
■ USER SELECTABLE CONFIGURATION UP TO 576K
■ USES 64K & 256K RAM CHIPS (OK INSTALLED)
MCT-RAM

EXPANDED MEMORY CARD \$129.95
2MB OF LOTUS INTEL MICROSOFT MEMORY FOR AN XT
■ CONFORMS TO LOTUS INTEL EMS ■ USER EXPANDABLE TO 2 MB ■ CAN BE USED AS EXPANDED OR CONVENTIONAL MEMORY, RAMDISK AND SPOOLER
MCT-EMS
MCT-AEMS 286/386 VERSION \$139.95

DISPLAY ADAPTORS

MONOCHROME GRAPHICS \$59.95
TRUE HERCULES COMPATIBILITY SUPPORTS LOTUS 1-2-3
■ PARALLEL PRINTER PORT CONFIGURES AS LPT1 OR LPT2 ■ USES VLSI CHIPS TO ENSURE RELIABILITY
MCT-MGP

EGA ADAPTOR \$149.95
100% IBM COMPATIBLE PASSES IBM EGA DIAGNOSTICS
■ 256K OF VIDEO RAM ALLOWS 640 X 350 IN 16 OF 64 COLORS ■ COMPATIBLE WITH COLOR AND MONOCHROME ADAPTORS ■ HERCULES COMPATIBLE
MCT-EGA

COLOR GRAPHICS ADAPTOR \$49.95
COMPATIBLE WITH IBM GRAPHICS STANDARDS
■ SUPPORTS RGB, COLOR, & COMPOSITE MONOCHROME
■ 640/320 X 200 RESOLUTION, LIGHT PEN INTERFACE
MCT-CG

MONOGRAPHICS MULTI I/O \$119.75
TOTAL SYSTEM CONTROL FROM A SINGLE SLOT!
■ CTRL 2 FLOPPIES, SERIAL, PARALLEL, GAME PORT, CLOCK CAL ■ RUN COLOR GRAPHICS SOFTWARE ON A MONOCHROME MONITOR
MCT-MGMI0

286/386 MONOGRAPHICS I/O \$99.95
VIDEO DISPLAY AND I/O FUNCTIONS IN ONE CARD
■ 720 X 348 RESOLUTION, 80 & 132 COLUMN TEXT
■ PARALLEL, SERIAL & GAME PORTS
MCT-MGAIO

BARGAIN HUNTER'S CORNER

MULTIFUNCTION CARD

- INCLUDES FULL ONE YEAR WARRANTY
- XT COMPATIBLE
- 638K DYNAMIC RAM USING 4184'S
- SERIAL PORT & PARALLEL PRINTER PORT
- GAME CONTROLLER PORT
- CLOCK/CALENDAR
- SOFTWARE FOR RAM DISK, PRINT SPOOLER AND CLOCK/CALENDAR

MCT-MF

ONLY \$59.95

SPECIAL ENDS 11/30/88



JDR MICRODEVICES, 110 KNOWLES DRIVE, LOS GATOS, CA 95030
LOCAL (408) 866-6200 FAX (408) 378-8927 TELEX 171-110

RETAIL STORE: 1256 SOUTH BASCOM AVE., SAN JOSE, CA (408) 947-8881
HOURS: M-F 9-7 SAT. 9-5 SUN. 12-4

ORDER TOLL FREE 800-538-5000

COPYRIGHT 1988 JDR MICRODEVICES

CONTINENTAL U.S. AND CANADA

TERMS: MINIMUM ORDER \$10.00 FOR SHIPPING AND HANDLING INCLUDE \$2.50 FOR UPS GROUND AND \$3.50 UPS AIR. ORDERS OVER 1 LB. AND FOREIGN ORDERS MAY REQUIRE ADDITIONAL SHIPPING CHARGES—PLEASE CONTACT THE SALES DEPARTMENT FOR THE AMOUNT. CA RESIDENTS MUST INCLUDE APPLICABLE SALES TAX. PRICES ARE SUBJECT TO CHANGE WITHOUT NOTICE. WE ARE NOT RESPONSIBLE FOR TYPOGRAPHICAL ERRORS. WE RESERVE THE RIGHT TO LIMIT QUANTITIES AND TO SUBSTITUTE MANUFACTURER. ALL MERCHANDISE SUBJECT TO PRIOR SALE. A FULL COPY OF OUR TERMS IS AVAILABLE UPON REQUEST. ITEMS PICTURED MAY ONLY BE REPRESENTATIVE.

BUILD YOUR OWN SYSTEM!

OVER 20,000 JDR SYSTEMS HAVE ALREADY BEEN BUILT. EASY TO ASSEMBLE IN JUST 2 HOURS WITH A SCREWDRIVER. SAVE MONEY AND LEARN MORE ABOUT YOUR COMPUTER AT THE SAME TIME!



VIDEO INSTRUCTIONS

\$4.95 WITH KIT PURCHASE
A JDR EXCLUSIVE! 20-MIN. VHS OR BETA TAPE SHOWS YOU STEP-BY-STEP HOW TO BUILD AN XT COMPATIBLE SYSTEM. W/O KIT \$19.95

10 MHz TURBO 8088
\$661⁰⁰

■ INCLUDES SERIAL PORT, 2 PARALLEL PORTS, CLOCK/CALENDAR AND GAME ADAPTOR ■ RUNS COLOR GRAPHICS ON A MONOCHROME MONITOR.
 ■ MOTHERBOARD ■ 256K RAM MEMORY ■ 135 WATT POWER SUPPLY ■ FLIP-TOP CASE ■ 84 KEY KEYBOARD ■ 360K FLOPPY DRIVE ■ MONOGRAPHICS I/O CARD ■ MONOCHROME MONITOR

12 MHz MINI-286
\$1232⁷⁵

■ 12 MHz MINI-286 MOTHERBOARD ■ 512K RAM MEMORY ■ MINI CASE WITH POWER SUPPLY ■ 84 KEY KEYBOARD ■ MONOCHROME MONITOR ■ 1.2 MB FLOPPY DRIVE ■ FLOPPY / HARD CONTROL ■ GRAPHICS ADAPTOR

16 MHz 1 Mb 386
\$2348⁶⁵

■ MYLEX 386 MOTHERBOARD ■ 1 MB RAM ON BOARD ■ 200 WATT POWER SUPPLY ■ CASE ■ ENHANCED KEYBOARD ■ 1.2 MB FLOPPY DRIVE ■ FLOPPY/HARD CONTROLLER ■ MONOGRAPHICS CARD ■ MONOCHROME MONITOR

MOTHERBOARDS

TURBO 4.77/8 MHz

\$99.95

■ XT COMPATIBLE ■ NORTON SI 1.7 ■ 4.77 OR 8 MHz OPERATION WITH 8088-2 AND OPTIONAL 8087-2 CO-PROCESSOR ■ FRONT PANEL LED SPEED INDICATOR AND RESET SWITCH SET SUPPORTED ■ CHOOSE NORMAL/TURBO MODE OR SOFTWARE SELECT PROCESSOR SPEED

MCT-TURBO
 MCT-XMB STANDARD MOTHERBOARD\$87.95

10 MHz TURBO SINGLE CHIP 8088

\$129.95

■ XT COMPATIBLE ■ NORTON SI 2.1 ■ USES LESS POWER, IMPROVES RELIABILITY ■ KEY SELECTABLE SPEED, 4.77 MHz OR 10 MHz ■ 2.3 TIMES FASTER THAN A STANDARD SWITCH, KEYLOCK, AND SPEED / POWER INDICATORS SUPPORTED

MCT-TURBO-10

80286 6/10 MHz

\$379.95

■ AT COMPATIBLE ■ LANDMARK AT SPEED 10 MHz ■ NORTON SI 10.3 ■ 8 SLOTS (TWO 8-BIT, SIX 16-BIT) ■ HARDWARE SELECTION OF 6 OR 10 MHz ■ FRONT PANEL LED INDICATOR ■ SOCKETS FOR 1MB OF RAM AND 80287 ■ ONE WAIT STATE ■ BATTERY BACKED CLOCK ■ KEYLOCK SUPPORTED ■ RESET SWITCH

MCT-286

12 MHz MINI-286

\$399.95

■ AT COMPATIBLE ■ LANDMARK AT SPEED 13.2 MHz ■ NORTON SI 11.5 ■ 6 MHz, 10 MHz (0/1 WAIT STATE), 12 MHz (1 WAIT STATE) ■ ZYMOS ASICS FOR FEWER CHIPS, GREATER RELIABILITY ■ SUPPORTS 512K-1024K MEMORY ■ RECHARGEABLE HIGH CAPACITY NI-CAD BATTERY ■ SIX 16-BIT SLOTS, TWO 8-BIT SLOTS ■ MOUNTS IN STANDARD XT CASE

MCT-M286-12
 MCT-M286 6 /10 MHz MINI 80286 BOARD\$389.65

16 MHz MYLEX 386

\$1699.00

■ 1 MB RAM ON BOARD ■ 8 SLOTS (TWO 8-BIT, SIX 16-BIT) ■ USES AMI BIOS ■ SUPPORTS 80287 MATH CO-PROCESSOR ■ SUPPORTS 80387 WITH ADAPTOR ■ 64KB CACHE FOR NEAR 0 WAIT STATE ■ 20 MHz VERSION AVAILABLE

MY-386MB
 MY-386MB-4 FOUR MB MEMORY INSTALLED\$2999.00

MY-386MB-MCB MATH CO-PROCESSOR ADAPTOR BOARD\$149.00

16 MHz MYLEX MINI 386

\$1249⁰⁰

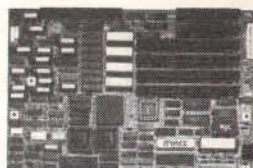

■ LANDMARK AT SPEED 23.2 MHz ■ NORTON SI 18.7 ■ 64KB HIGH SPEED DIRECT MAPPED STATIC RAM CACHE ■ 1 MB OR 2 MB MEMORY ON STD. MEMORY BOARD ■ UP TO 8 MB OF 32-BIT MEMORY ON PIGGYBACK MEMORY BOARD, FOR TOTAL OF 10 MB ■ AMI BIOS WITH 32 BIT EGA SUPPORT ■ SOCKETED FOR 80387 MATH CO-PROCESSOR ■ ONE 8-BIT, FOUR 16-BIT AND ONE 32-BIT SLOTS ■ DALLAS CMOS /CLOCK DEVICE ON BOARD W/ BATT.

MY-386 JR (MEMORY CARD REQUIRED)\$1695.00

MY-386JR-20 20 MHz VERSION\$159.00

MY-386JR-M 1 TO 2 MB MEMORY CARD (REQUIRED) 0x INSTALLED\$159.00

MY-386JR-M8 8 MB PIGGYBACK MEMORY BOARD 0x INSTALLED\$159.00

NEW! MODULAR PROGRAMMERS

THE IDEAL SYSTEM FOR DEVELOPERS. ALL MODULES USE A COMMON HOST ADAPTOR CARD

HOST ADAPTOR CARD \$29.95

■ A UNIVERSAL INTERFACE FOR ALL THE PROGRAMMING MODULES ■ USER SELECTABLE PROGRAMMABLE ADDRESSES PREVENT ADDRESSING CONFLICTS ■ MENU-DRIVEN SOFTWARE PACKAGE ■ INCLUDES MOLDED CABLE

MCT-MAC

UNIVERSAL MODULE \$499.99

■ PROGRAMS EPROMS, EEPROMS, PALS, BI-POLAR PROMS 8748 & 8751 SERIES DEVICES ■ TESTS TTL, CMOS, DYNAMIC & STATIC RAMS

MCT-MUP

DIGITAL IC MODULE \$129.95

■ TESTS TTL, CMOS, DYN. & STATIC RAM ■ AUTO SEARCH

MCT-MIC

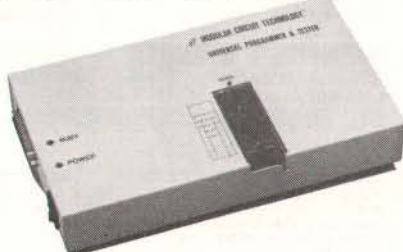

EPROM MODULE \$119.95

■ PROGRAMS 24-32 PIN EPROMS, CMOS EPROMS AND EEPROMS FROM 16K TO 1024K

MCT-MEP

MCT-MEP-4 FOUR-EPROM PROGRAMMER\$169.95

MCT-MEP-8 EIGHT-EPROM PROGRAMMER\$259.95

PAL MODULE \$249.95

■ PROGRAMS MMI, NS, TI 20 & TI 24 PIN DEVICES

MCT-MPL

8748 MODULE \$179.95

■ PROG. 8741, 8742, 8748, 8749 & 8750 EPROMS & PROMS.

MCT-MMP

BI-POLAR MODULE \$259.95

■ PROG. AMD, MMI, NS, TI & SIGNETICS BI-POLAR PROMS

MCT-MBP

JDR Microdevices®

JDR MICRODEVICES, 110 KNOWLES DRIVE, LOS GATOS, CA 95030

LOCAL (408) 866-6200 FAX (408) 378-8927 TELEX 171-110

ORDER TOLL FREE 800-538-5000

COPYRIGHT 1988 JDR MICRODEVICES

BBS (408) 374-2171

CONTINENTAL U.S. AND CANADA



6800 Family Development Software



Combine our software and your editor for a powerful development system. Our C-Compilers feature a complete implementation (excluding bit fields) of the language as described by Kernigan & Ritchie and yields 30-70% shorter code than other compilers. Our Motorola-compatible Assemblers feature macros and conditional assembly. Linker and Terminal Emulator are included.

WINTEK Wintek Corporation
1801 South Street
Lafayette, IN 47904-2993
(317) 742-8428 or (800) 742-6809

Circle 394 on Reader Service Card

DIGITAL OSCILLOSCOPE SYSTEM \$99

AD8-1 card & DIG-OSC-B Software

- * Analog input
- * 8 bit resolution
- * use as a storage scope
- * save waveform to disk
- * 10uS conversion
- * High input impedance
- * 0-5V range
- * 7 TTL inputs
- * for IBM PC and compatibles



DAS 12 \$299

- * 12 bit Data Acquisition System
- * 8 differential input channels
- * High input impedance
- * software selectable GAIN of 1, 10, 100
- * Full Scale: +/- 10V, 5V, 500mV, 50mV
- * 25uS conversion time
- * Sample/hold for precision readings
- * software included to simulate auto-ranging DVM
- * 7 TTL I/O
- * option available: 12 bit analog output, add \$100

DIO96MP \$199

- * 96 programmable digital TTL I/O
- * save space, use only 1 slot in PC
- * option available: converts 24 outputs to high current, high voltage, open collector outputs (300mA, 50V) add \$50

All boards have a user manual, demo software with source code in Pascal, BASIC, C and a one year warranty.

JB COMPU-TRONIX
3816 N. Wadsworth Blvd.
Wheat Ridge, CO 80033
(303) 425-9586

Call for FREE CATALOG, accept MC/VISA orders

Circle 398 on Reader Service Card

BULK DISKS

All Items In Stock
100% Guaranteed
MC, VISA, COD Accepted
24 Hour Shipment
Call For Our Monthly Specials

3.5" DS/DD	
■ SONY	1.29
■ DATASAFE	1.19
■ TDK DS/HD	3.85
5.25" DS/HD	
■ TDK	1.29
■ DATASAFE	.89
5.25" DS/DD	
■ MAXELL	.64
■ VERBATIM	.59
■ 3M	.57
■ DATASAFE	.35

Prices based on 200 Disks
Includes Labels, Sleeves & Tabs
Smaller Quantities Available

In NJ **800-426-0247** FAX
201-892-5655 201-892-6186

**PRINCETON
DISKETTE**

432 Macarthur Dr. ■ Brick, NJ 08724

Circle 259 on Reader Service Card

PROGRAMMERS FOR IBM PC/XT/AT



- Select Device with vender name & type number directly
 - Enable user to set up Program Pulse Width, Vpp, Vcc, Over-program Pulse Width & Iteration Counts.
 - Capable of set & 8/16/32-bits wide—word programming.
- | | | |
|----------|---|-------|
| XP6000A | Adapter & cable installs in PC for connecting programmer externally | \$55 |
| XP6001 | 1-socket 1M-bits EPROMs programmer | \$160 |
| XP6002 | 8-socket 1M-bits EPROMs programmer | \$375 |
| XP6003 | 1-socket MCS-48 micros programmer | \$215 |
| XP6004 | 1-socket MCS-51 micros programmer | \$270 |
| XP6014 | 4-sockets 1M-bits EPROM programmer | \$260 |
| AT-101/A | EPROM Eraser erases 30 24-pin ICs with timer | \$195 |

2 YEARS GUARANTY + 30 DAYS MONEY BACK WARRANTY
Xender Corporation
2824, KENNEDY BLVD., J.F.L., JERSEY CITY, NJ 07306
TEL: 201-659-8291 Tlx: 910 240 4444 CHAMPION
FAX: 201-864-0737

Circle 363 on Reader Service Card



**Sure
it's insured?**

SAFWARE® Insurance provides full replacement of hardware, media and purchased software. As little as \$39/yr. covers:

- Fire • Theft • Power Surges
- Earthquake • Water Damage • Auto Accident

For information or immediate coverage call:
1-800-848-3469

In Ohio call 1-614-262-0559



SAFWARE, The Insurance Agency Inc.

Circle 290 on Reader Service Card

Easy as a keystroke

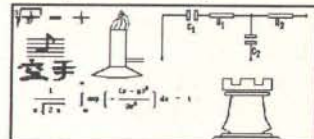

FontStyle

for Turbo Pascal 4.0, Turbo C, MS C, Quick C... You can use it with the BGI-Interface from Borland or with nearly every compiler with graphic capabilities. FontStyle, the editor for outlined fonts makes the output of formulas, symbols or new fonts as easy as putting a string on the screen.

Get your FontStyle for **49.99\$**

Xetec, Inc., 2804 Arnold Rd.,
Salina, KS 67401, 913-827-0685

Circle 278 on Reader Service Card

Advertise your
computer products
through
BYTE BITS
(2" x 3" ads)

For more information
call Dan Harper at
603-924-6830

BYTE
70 Main St.
Peterborough, NH 03458

TRANSLATE BASIC TO PASCAL

P-TRAL,
Woodchuck
Industries'
program for IBM
PC and MS-DOS
compatibles
translates
Microsoft BASIC
source code to Turbo Pascal source.
Comes with full documentation and
tutorial. \$179.00



P-Tral is also available for the
Apple II series. Write or call for more
details.

WOODCHUCK INDUSTRIES, INC.
340 WEST 17 STREET Ste 2B NY, NY 10011
(212) 206-6490 / 924-0576

Circle 361 on Reader Service Card

IEEE-Z

Easiest IEEE 488(GPIB/HPIB)
Interfaces for your PC, PS/2,
Macintosh, HP and more!

- Controllers
- Converters
- Extenders
- Buffers
- Boards



Please see our ad
on page 208.

Call or send
for your **FREE**
Technical Guide

Lotech (216) 439-4091

25971 Cannon Road • Cleveland, Ohio 44146
Telex 6502820864 • Fax (216) 439-4093

Circle 167 on Reader Service Card

EDITORIAL INDEX BY COMPANY

Index of companies covered in articles, columns, or news stories in this issue
Each reference is to the first page of the article or section in which the company name appears

INQUIRY #	COMPANY	PAGE	INQUIRY #	COMPANY	PAGE	INQUIRY #	COMPANY	PAGE
	ADDISON-WESLEY	51		TECHNOLOGIES	135	769	MSC TECHNOLOGIES	67
758	ADRA SYSTEMS	67	779	ENGINEERING SOFTWARE CONCEPTS	67	851	NEC HOME ELECTRONICS	89
757	ADVANCED GRAPHIC APPLICATIONS	67		EUROPEAN COMMUNITY COMMISSION	11	852	NESTOR	11
885	ADVANCED LOGIC RESEARCH	205	773	FALK DATA SYSTEMS	67	947	NEXT	158
952	AJIDA TECHNOLOGIES	180	888	GIBSON RESEARCH	105, 237		NORTH AMERICAN MICA	180
	ALLIANT COMPUTER SYSTEMS	275	940	GIMEOR	67		NORTHGATE	254
	ALSYS	11	778	GIMPEL SOFTWARE	229		NTH GRAPHICS	287
	AMERITECH	153	890	GLOCKENSPIEL	287		NYNEX	153
	AOX	301	942	GOLDEN BOW	105	840	1STAIID SOFTWARE	139
751	APPLE COMPUTER	11, 67, 254	770	GW INSTRUMENTS	67		ORACLE	11
784	APPLITECH SOFTWARE	67	771	GW3	67		PACIFIC BELL	153
891	ASHTON-TATE	241	764	HARRIS	67		PARALLEL SYSTEMS TECHNOLOGY	387
763	AST RESEARCH	67		HAYDEN BOOKS	51	786	PAUL MACE SOFTWARE	67
	BELL ATLANTIC	153		HUGHES RESEARCH LABORATORIES	311	760	PERFECTEK	67
	BELLSOUTH	153		HUMAN DEVICES	301	856	PETER NORTON COMPUTING	89
781	BINARY ENGINEERING	67		IMPERIAL COLLEGE	387	785	PHOENIX PHIVE SOFTWARE	67
	BOLT BERANEK AND NEWMAN	275	966	INDEX TECHNOLOGY	135	792	POLYGON	67
964	BORLAND INTERNATIONAL	135	955	INFORMIX	11		PRENTICE-HALL	51
	BRAINWARE	387		INMOS	320	963	PRODEX DEVELOPMENT	135
934	BRODERBUND SOFTWARE	127		INSIGNIA SOLUTIONS	11	946	PROJECTRONIX	180
761	CABLESOFT	67		INSITE PERIPHERALS	11		RELATIONAL TECHNOLOGY	11
	CAERE	254	944	INSTAPLAN	180		RELISYS	11
936	CAMBRIDGE/NORTH AMERICA	127	762	INTEL PCEO	67	802	RESPONSIVE SOFTWARE	67
767	CAYMAN SYSTEMS	67		ITHACA SOFTWARE	287	797	S. H. MOODY & ASSOCIATES	67
	CIRRUS LOGIC	11		JAPAN COMPUTER EDUCATION DEVELOPMENT CENTER	11		SANDIA NATIONAL LABORATORY	275, 301
959	COGENT RESEARCH	275, 301, 320	842	JASMINE	139		SCIENTIFIC COMPUTING ASSOCIATES	301
	COGNITION	11	843			948	SILICON GRAPHICS	11
951	COMMUNICATIONS DYNAMICS	180	774	JYACC	67	945	SOFTCORP	180
854	COMPAQ COMPUTER	89, 197	852	KINETICS	67	855	SOFTRAK SYSTEMS	180
883				KODAK	11	787	SPIRIT OF PERFORMANCE	89
953	COMPUTER AIDED MANAGEMENT	180	768	KURTA	67	841	STATE OF THE ART	67
949	COMPUTER ASSOCIATES INTERNATIONAL	180	887	LEVCO	213, 287, 320	941	SUPERMAC SOFTWARE	139
776	COMPUTER INNOVATIONS	67	956			950	SUPRA	105
	COMPUTER RESEARCH INSTITUTE	387		LINN PRODUCTS	340	961	SYBASE	11
886	COMPUTER SYSTEMS ARCHITECTS	213	938	LOCUS COMPUTING	105	950	SYMANTEC	135, 180
965	CONDOR COMPUTER	135	793	LOGISTIQUE LMM	67	943	SYSTEMS COMPATIBILITY	105
	COROLLARY	11	788	LORD PUBLISHING	67		THE PARLOG GROUP SECRETARY	387
889	CROSSTALK COMMUNICATIONS	249	765	MADGE NETWORKS	67	791	THINKING MACHINES	275
	CSA	287	780	MATHSOFT	67		3X USA	67
798	DATA TRANSLATION	67	756	MAXIMUM STORAGE	11, 67	799	TOPOLOGIX	301
	DATA CUBE	11	772	MCGRAW-HILL BOOK	399		TRANSPOWER	67
796	DATAPERCEPTIONS	67	958	MICROSOFT	67, 127, 147, 363	939	UNIVERSAL DATA MANUFACTURING	105
967	DAY-TIMERS	135		MICROWAY	287, 320	937	USROBOTICS	105
766	DAYNA			MIT PRESS	51		VIDEOTEX INFORMATION ASSOCIATION	153
844	DAYNA COMMUNICATIONS	67, 139				752	WANG LABORATORIES	67
845						790	WORDPERFECT	67
957	DEFINICON SYSTEMS	287, 320				755	XECOM	67
	DEPARTMENT OF DEFENSE	11					XIDEX	11
962	DEPARTMENTAL TECHNOLOGIES	135				753	YAMAHA MUSIC	67
						960	ZENITH DATA SYSTEMS	11, 320

COMING UP IN BYTE

PRODUCTS IN PERSPECTIVE:

As we go to press for November, here is the tentative lineup of articles on tap for December. While last-minute changes or delays can always occur, the following are those pieces we plan to bring to you.

In the **front of the book**, as usual, will be the Microbytes, Nanobytes, and What's New Sections, along with Short Takes—next month on new languages, add-ins, printers, and more. Putting in their usual appearance will be columnists Jerry Pournelle, with Computing at Chaos Manor; Ezra Shapiro, with Applications Plus; Wayne Rash, with Down to Business; Don Crabb, with Macinations; Brock N. Meeks, with COM1.; and Mark Minasi, with OS/2 Notebook.

First Impressions for December will include a look at a new relational database and a new 80286 laptop.

The **Product Focus** for December will look at low-cost plotters. Over 20 plotters were assembled at the BYTE Lab and put through a series of standardized tests. Every size and configuration, from desktop to free-standing to wall-mounted, were given a thorough going-over by our lab staff and technical editors.

System reviews will include the Sun 386i and the Dell System 220. Both are 80386-based systems that, in their own ways, should be of interest.

The Quickcapture board from Data Translation will be the focus of a **hardware review**. It is a black-and-white image capture card for the Macintosh.

In **software reviews**, we look at Merge 386, a DOS/Unix hybrid from Locus, and Slick, a text editor from MicroEdge.

Application reviews include Lotus Agenda and MacDraw II.

IN DEPTH:

Our In-Depth section deals with **groupware** in December and includes the following articles: an overview on collaborative work systems, groupware versus local-area network applications, artificial intelligence techniques in groupware, and a roundup of groupware products.

FEATURES:

We'll have Ciarcia's **Circuit Cellar** and Rick Grehan's **Some Assembly Required** for hardware and software constructionists, respectively. Additionally, we'll have pieces on **open look Unix**, **writing tidier Pascal code**, and **avoiding the fallacies of believing everything your calculations tell you**.

MAIL PREFERENCE SERVICE

In today's fast-paced society, shopping by mail or phone has become a popular, time-saving way to purchase many products and services. Most people enjoy receiving catalogs and other direct advertising, informing them of what's available through the mail.

You can obtain a free booklet called "Shopping at Home: A Consumer Guide" by sending your name and address to the Consumer Services Department of the Direct Marketing Association. The booklet provides the necessary information to make informed purchase decisions.

However, some people are not interested in receiving advertising mail and the Direct Marketing Association's Mail Preference Service (MPS) offers a free name removal service to consumers. Many companies participate because it's good business to send their message to people interested in their product. Recently, it has been enhanced to include non-profit organizations. You can specify which lists you would prefer to be removed from — commercial and/or non-profit.

So, if you wish to have your name deleted from many national advertising mailing lists, send us the coupon below and we'll let the participating mailers know. After several months, MPS should greatly reduce the amount of national advertising mail you receive. However, many local businesses and community organizations are not participants and will continue to send direct mail. In these cases, your name can be removed from their mailing list by writing directly to the mailer.

Name _____

Street _____

Apt. _____

City _____

State _____

ZIP _____

Variations of my name _____

MAIL PREFERENCE SERVICE
Direct Marketing Association
6 East 43rd Street
P.O. Box 3861 Grand Central Station
New York, NY 10163

READER SERVICE

To get further information on the products advertised in BYTE, fill out the reader service card by circling the numbers on the card that correspond to the inquiry number listed with the advertiser. This index is provided as an additional service by the publisher, who assumes no liability for errors or omissions.

Index to Advertisers by Product Category

Inquiry No.	Page No.	Inquiry No.	Page No.	Inquiry No.	Page No.	Inquiry No.	Page No.
HARDWARE							
545	ADD INS	120	ELEXOR 450	552	MONITORS	155	HIGH RES TECH 440
18	ALPHA PRODUCTS CO 455	161	INDUSTRIAL AUTOMATION 424	400	CHIEN-HOU ELECTRONICS 333	444	IRIS 88IS-11
35	ATI TECHNOLOGIES 50	167	IO TECH 465	84	CTX INT'L 362	195	LOGITECH 87
*	BINARY TECH 456	398	JB COMPU-TRONIX 465	222	MITSUBISHI 110,111	196	LOGITECH 87
426	BLUE CHIP TECHNOLOGY 88IS-42	242	ORION 84	85	CTX INT'L 362	351	VIDEX 310
63	CAPITAL EQUIPMENT 296	338	TMI, INC. 446	221	MITSUBISHI 110,111		
82	CONTROL VISION 456	549	KEYBOARDS/MICE	222	MITSUBISHI 110,111	558	SOFTWARE SECURITY
86	CURTIS 52	311	CAPS 317	231	NANAO 204	430	COMPUTER ELEKTRONIK 88IS-27
*	DATRAN CORP. 141	312	CAPS 317	232	NANAO 204	264	PROTECH MARKETING 98
94	DEFINICON 308	401	DATACOMP 338	453	PHILLIPS 88IS-2	280	RAINBOW TECH. 173
95	DEFINICON 308	408	HONOTRON CORP. 338	260	PRINCETON GRAPHIC 41	309	SOFTWARE SECURITY 31
96	DEFINICON 407	168	ITAC SYSTEMS 114	415	ROYAL INFO. ELECT. CO. 337		
97	DEFINICON 407	193	LOGITECH 74,75	328	TATUNG 167	559	SYSTEMS
102	DIGIBOARD 346,347	194	LOGITECH 74,75	459	TVM 88IS-52	422	ABC COMPUTER 88IS-45
103	DIGIBOARD 346,347	550	MASS STORAGE	2	10 NET COMMUNICATIONS 286	527	ALTEC TECHNOLOGY 88PC-4
145	GTEK INC. 96	14	AK SYSTEMS 446	*	AT & T 350,351	22	AMERICAN RESEARCH 146
146	GTEK INC. 96	30	ARCHIVE 291	43	BAY TECH ASSOC. 55	23	AMERICAN RESEARCH 146
443	INES 88IS-38	31	ARCHIVE 291	56	BUFFALO PRODUCTS 143	25	AMERICAN SEMICONDUCTOR 448
164	INTEL 156,157	126	EVEREX 73	431	CUBIX 88IS-39	*	AMPRO COMPUTER INC. 248
166	IO TECH 208	127	EVEREX 73	432	DATEX 88IS-21	32	AST RESEARCH 7
409	LABWAY COMPUTER CO. LTD. 337	141	GENOA 79	405	GOOD WAY INDUSTRIAL CO., INC. 337	33	AST RESEARCH 7
187	LAWSON LABS 424	449	NIPPON COLUMBIA 88IS-41	406	GUIS INC. 334	44	BEST COMPUTER 212
220	MICROWAY 398	271	QUALSTAR 454	169	ITRON 217	45	BEST COMPUTER 212
238	NOHAU CORP. 424	322	SYSGEN 19	448	MUTEK LTD 88IS-42	476	CAMBRIDGE DIRECT 88MW-1
250	PERISCOPE 126	324	TALLGRASS TECH 45	379	NATURAL MICROSYSTEMS 130	486	CAMBRIDGE DIRECT 88M/AT-1
252	PERSONAL SPACE COMM. 392	325	TALLGRASS TECH 45	252	PERSONAL SPACE COMM. 392	511	CAMBRIDGE DIRECT 88NW-1
266	QUA TECH 440	348	VERBATIM CORP. 107	286	ROSE ELECTRONICS 231	*	CLUB AMERICAN TECH. 22,23
267	QUA TECH 440			287	ROSE ELECTRONICS 454	64	COMPAQ 32A-D
268	QUA TECH 440			288	ROSE ELECTRONICS 454	397	COMTRAD INT'L 452
269	QUA TECH 440			418	TAIWAN 1ST LINE COMP. CABLE 334	479	COM-TEK DATA 88MW-7
281	REAL TIME DEVICES 454			392	WIESEMANN & THEIS GMBH 148	515	COM-TEK DATA 88NE-12
414	REAL TIME INDUSTRIAL CO. LTD. 338			554	POWER SUPPLIES	376	CORTEX 115
313	SOTA TECHNOLOGY 219			380	EMERSON COMP. POWER 352	377	CORTEX 115
366	Z-WORLD 442			381	EMERSON COMP. POWER 352	*	DATAWORLD 393
367	Z-WORLD 442			245	PARA SYSTEMS 359	94	DEFINICON 308
546	DRIVES			251	PERMA POWER 46	95	DEFINICON 308
244	PACIFIC RIM SYSTEMS 58			298	SENDON 60	96	DEFINICON 407
386	SUMITRONICS 315			555	PRINTERS/PLOTTERS	97	DEFINICON 407
387	SUMITRONICS 315			423	ACER 88IS-43	98	DELL COMPUTERS (INT'L) 176,177
326	TANDON 360,361			11	AEG OLYMPIA 123	98	DELL COMPUTERS (N.AMER.) 176-179
327	TANDON 360,361			43	BAY TECH ASSOC. 55	384	DTK COMPUTER 369
336	TIGERTRONICS 142			88	C. ITOH 300	385	DTK COMPUTER 369
357	WELTEC 218			89	C. ITOH 300	434	ELONEX 88IS-13
358	WELTEC 218			153	HEWLETT-PACKARD 201	124	EVEREX 28,29
547	HARDWARE PROGRAMMERS			203	MANNESMANN TALLY 61	125	EVEREX 28,29
*	AVOCET SYSTEMS 454			204	MANNESMANN TALLY 61	129	FIVESTAR CORP. 82,83
*	B & C MICRO 442			223	MITSUBISHI 113	137	GATEWAY 2000 121
54	BP MICROSYSTEMS 424			224	MITSUBISHI 113	404	GODSPEED COMPUTER 338
54	BP MICROSYSTEMS 424			*	NEC INFO SYSTEMS 358	441	H.M. SYSTEMS 88IS-15
57	BYTEK 446			239	OKIDATA 377	160	IEEE 117
145	GTEK INC. 96			343	UNITED INNOVATIONS 308	410	LYI-CHENG ENTERPRISES 333
146	GTEK INC. 96			10	VENTURA PERIPHERALS 150,151	213	MEGATEL 54
184	KORE INC. 456			365	ZERICON 309	215	MICRO EXPRESS 386
188	LINK COMPUTER 450			556	PRINTER RIBBONS	216	MICRO EXPRESS 386
191	LOGICAL DEVICES 442			*	BEST WESTERN 218	*	MICROWAY 274
192	LOGICAL DEVICES 442			557	SCANNERS/DIGITIZERS	220	MICROWAY 398
236	NEEDHAMS ELECTRONICS 452			311	CAPS 317	537	MS ENGINEERING, INC. 88PC-10
277	QUICKSOFT 32			312	CAPS 317	538	MS ENGINEERING, INC. 88PC-10
362	XELTEK 392			373	CORECO 247	452	OLIVETTI 88IS-19
363	XENDER 465			130	FLAGSTAFF ENGINEERING 163	240	OMEGA MICRO SYSTEMS 230
548	INSTRUMENTATION			131	FLAGSTAFF ENGINEERING 163	412	OST-EMPRO ELECT. CO. LTD. 335
391	COMPUTER CONTINUUM 456					489	OWL COMPUTER 88M/AT-3
						413	PAOKU P&C CO., LTD. 335
						248	PC DESIGN 203
						454	PROTECH SYSTEMS CO. 88IS-26
						279	RADIO SHACK CIV
						399	RADIO SHACK 307
						293	SCHWAB CORP. 453
						457	SEMI TECH MICRO 88IS-17
						519	SF MICRO 88NE-7
						540	SF MICRO 88PC-5

READER SERVICE

Advertising Supplement included with this issue:
Computer Mail Order (U.S. and Canada Subscribers)

* Correspond directly with company.

Inquiry No.	Page No.	Inquiry No.	Page No.	Inquiry No.	Page No.	Inquiry No.	Page No.
498 SF MICRO	88SE-7	207 MATHSOFT	69	344 USERSOFT	8,9	478 COMPARE COMPUTERS	88MW-5
319 SUNTRONICS	118	368 NATIONAL INSTRUMENTS	138	349 VESTRONICS	236	487 COMPARE COMPUTERS	88M/AT-5
417 TAIPEI COMPUTER ASSOC.	323	369 NATIONAL INSTRUMENTS	138			488 COMPARE COMPUTERS	88M/AT-5
329 TATUNG	169	539 NEURALWARE INC.	88PC-11	571 IBM/MS-DOS - UTILITIES		512 COMPARE COMPUTERS	88NE-8
419 TATUNG	327	295 SCIENTIFIC COMP. ASSOC.	453	5 A + L MEIER VOGT	227	513 COMPARE COMPUTERS	88NE-8
339 TOSHIBA	194,195	314 SPECTRUM	81	7 ABRAXAS SOFTWARE INC.	358	382 COMPUCLASSICS	365
340 TOSHIBA	194,195	316 STATSOFT	305	15 ALDRIDGE COMPANY, THE	106	383 COMPUCLASSICS	365
541 TRANSCOMPUTER	88PC-8	318 STSC	191	36 ATRON	66	77 COMPUTER EXPO	417
352 VNS AMERICA	27	278 XETEC INC.	465	39 AVOCET SYSTEMS	53	79 COMPUTER SURPLUS STORE	456
353 VNS AMERICA	149			46 BLAISE	33	80 COMPUTERLANE	211
354 VNS AMERICA	345	566 IBM/MS-DOS APPLICATIONS		60 CALIF. SOFTWARE PROD.	440	528 COMPUTOWN	88PC-12
355 VNS AMERICA	415	Miscellaneous		61 CALIF. SOFTWARE PROD.	440	81 CONTECH	448
356 WELLS AMERICAN	13	118 ECOSOFT	320	429 CLARION	88IS-5	516 COTTAGE COMPUTERS	88NE-2
364 ZENITH DATA SYSTEMS	59	206 MAP INFO SYSTEMS	18	529 COPY TECHNOLOGIES	88PC-1	433 DATRONIC GMBH	88IS-30
371 ZEOS INT'L	56,57	567 IBM/MS-DOS - CAD		530 COPY TECHNOLOGIES	88PC-1	110 DISC INTERNATIONAL	446
		8 ACCEL TECH	446	90 DATACODE	100	111 DISKOTECH	450
		38 AUTODESK	243	92 DAYSTAR COMPUTING	413	112 DISKETTE CONNECTION	453
		58 CAD SOFTWARE	376	143 GOLDEN BOW SYSTEM	450	113 DISKS TO GO	448
		132 FORESIGHT RESOURCES	36,37	148 HAMMERLY COMP. SERVICES	193	115 DYNAMIC ELECTRONICS	450
		133 FORESIGHT RESOURCES	36,37	154 HI TECH EQUIP CORP.	453	116 DYNAMIC ELECTRONICS	450
		440 GTCO	88IS-31	173 JENSEN & PARTNERS INT'L	85	480 D-DATA	88MW-3
		455 RHV	88IS-37	208 MATRIX	112	531 D-DATA	88PC-6
		360 WINTEK CORP.	5	447 MICROCOSM RESEARCH	88IS-44	517 ELECTRIFIED DISCOUNTERS	88NE-5
		394 WINTEK CORP.	465	228 MIX SOFTWARE	411	501 GEN. BUSINESS MACHINES	88SW-1
		568 IBM/MSDOS - LAN		254 PETER NORTON	209	438 GREY MATTER	88IS-46
		2 10 NET COMMUNICATIONS	286	255 PETER NORTON	209	149 HARD DISK DRIVES INT'L	222
		* AT & T	350,351	378 PUBLISHING TECHNOLOGIES	244	150 HARD DISK DRIVES INT'L	222
		52 BORLAND	71	265 QSET	60	159 IC EXPRESS	446
		53 BORLAND	71	270 QUAID SOFTWARE	344	170 JADE	441
		302 SIMPLE NET SYSTEMS	152	308 SOFTWARE MASTERS	133	171 JAMECO	438,439
		303 SIMPLE NET SYSTEMS	152	321 SUPERSOFT	384	390 JAMECO	255-270
		569 IBM/MS-DOS-GRAPHICS		342 TURBO POWER	116	174 J.D.R.	460,461
		333 BROWN BAG	303	* VERMONT CREATIVE	10	175 J.D.R.	462-464
		138 GENERAL PARAMETRICS	245	359 WENHAM SOFTWARE	454	536 KNAPCO	88PC-7
		440 GTCO	88IS-31	361 WOODCHUCK INDUSTRIES	465	496 KNAPCO	88SE-1
		442 IES	88IS-10			209 MEAD COMPUTER	449
		283 RIX SOFTWARE	104	572 IBM/MS-DOS COMMUNICATIONS		211 MEGASOFT	440
		284 RIX SOFTWARE	104	67 COEFFICIENT SYSTEMS	21	212 MEGASOFT	440
		570 IBM/MS-DOS - LANGUAGES		114 DIVERSIFIED COMP.	442	217 MICROCOM	24
		4 A + L MEIER VOGT	225	144 GRAFFPOINT	456	* MICROCOMP. MKTG. COUNCIL	88IS-34
		12 AETECH	90	178 KEA SYSTEMS	304	* MICROCOMP. MKTG. COUNCIL	421
		13 AETECH	90	179 KEA SYSTEMS	456	* MICROCOMP. MKTG. COUNCIL	88NE-8
		48 BORLAND	CII	395 PALLADIAN TECHNOLOGIES	448	* MICROCOMP. MKTG. COUNCIL	88SE-3
		49 BORLAND	CII	306 SOFTKLONE	389	219 MICROPROCESSOR UNLTD.	456
		50 BORLAND	1	307 SOFTRONICS	453	* MICROWAY	274
		51 BORLAND	1			220 MICROWAY	398
		428 CALEND	88IS-23	573 OTHER - LANGUAGES		229 MONTGOMERY GRANT	134
		65 CNS, INC.	30	435 EQUIPU AIR LTD	88IS-40	230 M.H.I.	443
		66 CNS, INC.	30			* NATIONAL COMP. ACCESS	445
		118 ECOSOFT	320	574 OTHER - CROSS DEVELOPMENT		237 NITRO MICRO	251
		121 ELLIS	304	* SOFTWARE DEV. SYS.	91	240 OMEGA MICRO SYSTEMS	230
		142 GOLD HILL COMPUTER	297			518 PC LINK CORP.	88NE-3
		439 GSE	88IS-29			249 PC NETWORK	284,285
		185 LAHEY COMPUTERS	296	575 MAIL ORDER/RETAIL		257 PRECISION DATA PRODUCTS	450
		197 LOGITECH	136	526 3-F ASSOCIATES	88PC-9	259 PRINCETON DISKETTE	465
		198 LOGITECH	136	9 ADVANCED COMP. PRODS.	458,459	* PRIORITY ONE	473-488
		199 LOGITECH	137	19 ALTEX ELECTRONICS	444	262 PROGRAMMER'S PARADISE	62,63
		200 LOGITECH	137	21 AMER. DESIGN COMPONENTS	447	263 PROGRAMMER'S SHOP	109
		205 MANX SOFTWARE SYSTEMS	99	393 B & B ELECTRONICS	446	* ROBT. TINNEY GRAPHICS	88IS-48
		227 MIX SOFTWARE	129	47 BOFFIN LTD	374	289 SABINA INT'L	452
		256 POLYTRON	408	* BUYERS MART	427-437	294 SCIENCE & ENG. S/W	357
		291 SANTA CRUZ OPERATION	233	* CALIFORNIA DIGITAL	457	299 SHAMROCK COMPUTER	97
		317 STSC	235	59 CALIFORNIA FREEWARE	108	300 SHECOM COMPUTERS	395
				70 COMPACT DISK PRODUCTS	52	301 SHECOM COMPUTERS	395
				477 COMPARE COMPUTERS	88MW-5	304 SKAN TEKNOLOGIES	454
						305 SN'W ELECTRONICS	210
						* SOFTLINE CORP.	88IS-33
						310 SOLUTION SYSTEMS	109
						458 S-100	88IS-35

Continued

Make a career move!

Get your own copy of BYTE!

Sharing is nice but not practical when you have to stay on the leading edge of microcomputer technology. From each BYTE issue theme to "MICROBYTES" and "Best of BIX," no other magazine—or group of magazines—can deliver you the vital technical information packaged in one issue of BYTE.

Don't rely on others for BYTE information—waiting in the queue can be hazardous to your job. Make a career move! Have BYTE delivered to your door in your name. Use one of the adjacent cards to ensure your position in microcomputer technology.

Subscription rates outside Europe available upon request. Please write to: BYTE Subscriptions Box 328 Hancock, NH 03449

For your own subscription to complete this card and post.

IBJ5088

Name _____

Address _____

City _____ Code _____

Country _____

Payment enclosed. (All cheques must be payable in pounds sterling.)

Charge to my Access EUROCARD VISA MasterCard
 American Express

Account # _____ Expiration Date _____

Signature _____

BYTE,



Subscription Rates

Enter my one year subscription (12 issues) as indicated below:

- £46 Sterling, air delivery to Europe. (Includes USSR, Turkey and Cyprus)
- £21 Sterling, fast surface delivery to Europe.

Payment or credit card information must accompany your order.

Please allow 6–8 weeks for processing. Thank you.

PLACE
STAMP
HERE

BYTE

McGraw-Hill Information Systems
McGraw-Hill House
Maidenhead, Berkshire SL6 2QL
England

Attn: International Circulation Department

For your own subscription to complete this card and post.

IBJ5088

Name _____

Address _____

City _____ Code _____

Country _____

Payment enclosed. (All cheques must be payable in pounds sterling.)

Charge to my Access EUROCARD VISA MasterCard
 American Express

Account # _____ Expiration Date _____

Signature _____

BYTE,



Subscription Rates

Enter my one year subscription (12 issues) as indicated below:

- £46 Sterling, air delivery to Europe. (Includes USSR, Turkey and Cyprus)
- £21 Sterling, fast surface delivery to Europe.

Payment or credit card information must accompany your order.

Please allow 6–8 weeks for processing. Thank you.

PLACE
STAMP
HERE

BYTE

McGraw-Hill Information Systems
McGraw-Hill House
Maidenhead, Berkshire SL6 2QL
England

Attn: International Circulation Department

Make a career move!

Get your *own*
copy of BYTE!

Sharing is nice but not practical when you have to stay on the leading edge of microcomputer technology. From each BYTE issue theme to "MICROBYTES" and "Best of BIX," no other magazine—or group of magazines—can deliver you the vital technical information packaged in one issue of BYTE.

Don't rely on others for BYTE information—waiting in the queue can be hazardous to your job. Make a career move! Have BYTE delivered to *your* door in *your* name. Use one of the adjacent cards to ensure your position in microcomputer technology.

For your own subscription to complete this card and post.

BYTE,



Name _____ IBJ5088

Address _____

City _____ Code _____

Country _____

Payment enclosed. (All cheques must be payable in pounds sterling.)

Charge to my Access EUROCARD VISA MasterCard
 American Express

Account # _____ Expiration Date _____

Signature _____

Subscription Rates

Enter my one year subscription (12 issues) as indicated below:

- £46 Sterling, air delivery to Europe. (Includes USSR, Turkey and Cyprus)
- £21 Sterling, fast surface delivery to Europe.

Payment or credit card information must accompany your order.

Please allow 6-8 weeks for processing. Thank you.

PLACE
STAMP
HERE

BYTE

McGraw-Hill Information Systems
McGraw-Hill House
Maidenhead, Berkshire SL6 2QL
England

Attn: International Circulation Department

Subscription rates outside Europe available upon request. Please write to:
BYTE Subscriptions
Box 328
Hancock, NH 03449

OUR NEW PRINTERS MAKE EVEN BAD WRITING LOOK GOOD.

CHAPTER ONE
THE BLACKEST HOUR IS MIDNIGHT

It was not a night fit for man or beast what with the sky being as black as ink and it starting to rain like cats and dogs. As if things weren't bad enough Jeffrey Whipple had to climb all the way up to the top of Bald Eagle hill in his snakeskin boots so new their smell reminded him of a car he once leased in Flagstaff, Arizona just to check things out because earlier in the day a message had gotten through that there was going to be trouble this night so he was feeling ominous as the dry wind whipped up the dust around his feet and wondering if he should go on or go back to camp when suddenly, he heard a twig crack behind him or thought he did but as he turned he could see anything except the black bleakness of the

We're sorry that our new 24-wire Pinwriter® P5200 and P5300 printers can't do much for the quality of your writing. But they can certainly do wonders for the way it looks. The secret is the ribbon. Other dot matrix printers only use a fabric ribbon. Our Pinwriters print with both a fabric and a letter-quality, multi-strike film ribbon—the same kind used on executive typewriters.

The NEC Pinwriters can also enhance your writing in other ways. They have seven resident type styles. Plus four more are available on plug-in font cards. Which means you can express your thoughts with just the right typeface. You can also get an inexpensive, user-installed color option. And if graphics are part of your story, these Pinwriters produce the highest resolution of any printer you can buy.

Call NEC Information Systems at 1-800-343-4418 to see how much better our new Pinwriter P5200 and the wider

P5300 can make your writing look.

Whether you're a budding
Hemingway, or a
Hemingway & Company.

**NEC PRINTERS. THEY ONLY STOP
WHEN YOU WANT THEM TO.**

NEC



NEC Information Systems, Dept. 1610, 1414 Massachusetts Ave., Boxborough, MA 01719.

Tandy® Computers: The broadest line of PCs in America.



The Tandy 5000 MC

Our most
powerful 386™
based computer
...made in America.

The new Tandy 5000 MC Professional System is pure performance, from the Intel® 80386 processor operating at 20 MHz to the memory cache controller that provides RAM-fast access to data.

With the 5000 MC, you have the high-performance platform needed to take the fullest advantage of industry-standard MS-DOS® applica-

tions, powerful new MS® OS/2 programs or multiuser SCO® XENIX® software.

Operating at 20 MHz, the 5000 MC cuts through the big jobs like database management, large spreadsheets and sophisticated graphics. Its IBM® Micro Channel™ compatible architecture allows multiple processors to use the same bus.

The system architecture also provides a radical increase in data-transfer rates when the Tandy 5000 MC is configured within a 3Com® workgroup or a multiuser environment.

The Tandy 5000 MC is the new alternative in personal computing—from the best-selling family of PC Compatibles made in America.

Tandy Computers: Because there is no better value.™

Intel/Reg. TM Intel Corp. IBM/Reg. TM and Micro Channel/TM IBM Corp. MS, MS-DOS and XENIX/Reg. TM Microsoft Corp. SCO/Reg. TM The Santa Cruz Operation. 3Com/Reg. TM 3Com Corp.

Radio Shack®
COMPUTER CENTERS
A DIVISION OF TANDY CORPORATION